

# RUN

CE

RUN1800  
RUN1800P  
RUN2500  
RUN2500P

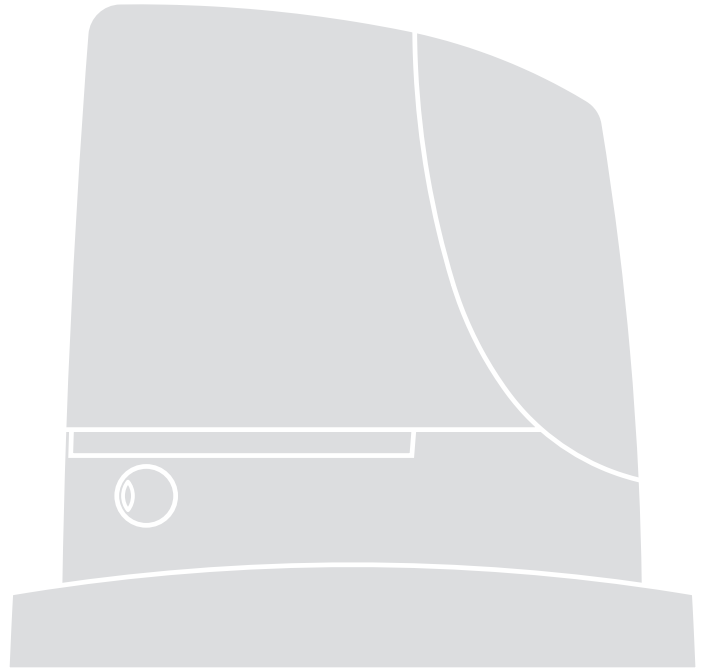

## Sliding Gate Opener

**HR** - Upute i upozorenja za ugradnju i uporabu

**EN** - Instructions and warnings for installation and use

**Nice**

<b>Kazalo:</b>	<b>str.</b>		
<b>1</b>	Upozorenja	3	
<b>2</b>	Opis proizvoda i namjena	4	
<b>2.1</b>	Radna ograničenja	4	
<b>2.2</b>	Tipičan sustav	6	
<b>2.3</b>	Popis kabela	6	
<b>3</b>	Ugradnja	7	
<b>3.1</b>	Prethodne provjere	7	
<b>3.2</b>	Pričvršćivanje motoreduktora	7	
<b>3.3</b>	Pričvršćivanje poluge granične sklopke kod verzija s induktivnom graničnom sklopkom	8	
<b>3.4</b>	Ugradnja raznih uređaja	9	
<b>3.5</b>	Električni spojevi	9	
<b>3.6</b>	Opis električnih spojeva	10	
<b>4</b>	Završne provjere i pokretanje	10	
<b>4.1</b>	Odabir smjera	10	
<b>4.2</b>	Priključenje napajanja	10	
<b>4.3</b>	Samostalno učenje uređaja	10	
<b>4.4</b>	Samostalno učenje dužine krila	11	
<b>4.5</b>	Provjera kretanja dvorišnih vrata	11	
<b>4.6</b>	Unaprijed postavljene funkcije	11	
<b>4.7</b>	Radioprijemnik	11	
<b>5</b>	Završno ispitivanje i puštanje u rad	11	
<b>5.1</b>	Završno ispitivanje	12	
<b>5.2</b>	Puštanje u rad	12	
<b>6</b>	Održavanje i odlaganje	12	
<b>6.1</b>	Održavanje	12	
<b>6.2</b>	Odlaganje	12	
<b>7</b>	Dodatne informacije	13	
<b>7.1</b>	Tipke za programiranje	13	
<b>7.2</b>	Programiranje	13	
<b>7.2.1</b>	Funkcije prve razine (funkcije UKLJUČENO-ISKLJUČENO)	13	
<b>7.2.2</b>	Programiranje prve razine (funkcije UKLJUČENO-ISKLJUČENO)		14
<b>7.2.3</b>	Funkcije druge razine (podesivi parametri)		14
<b>7.2.4</b>	Programiranje druge razine (podesivi parametri)		15
<b>7.2.5</b>	Primjer za programiranje prve razine (funkcije UKLJUČENO-ISKLJUČENO)		16
<b>7.2.6</b>	Primjer za programiranje druge razine (podesivi parametri)		16
<b>7.3</b>	Dodavanje ili uklanjanje uređaja		16
<b>7.3.1</b>	BlueBUS		16
<b>7.3.2</b>	Ulaz za STOP		17
<b>7.3.3</b>	Fotoćelije		17
<b>7.3.4</b>	Fotoćelija FT210B		17
<b>7.3.5</b>	RUN u načinu rada „Slave”		18
<b>7.3.6</b>	Samostalno učenje drugih uređaja		19
<b>7.4</b>	Posebne funkcije		19
<b>7.4.1</b>	Funkcija „Uvijek otvori”		19
<b>7.4.2</b>	Funkcija „Ipak pokreni”		19
<b>7.4.3</b>	Kontrolni sustav grijanja i hlađenja		19
<b>7.4.4</b>	Obavijest o potrebnom održavanju		19
<b>7.5</b>	Spajanje drugih uređaja		20
<b>7.6</b>	Rješavanje problema		21
<b>7.6.1</b>	Popis povijesti nepravilnosti		21
<b>7.7</b>	Dijagnostika i signali		21
<b>7.7.1</b>	Signaliziranje trepćućim svjetlom		22
<b>7.7.2</b>	Signaliziranja na kontrolnoj jedinici		22
<b>7.8</b>	Dodatna oprema		23
<b>7.8.1</b>	Jedinica za daljinsko programiranje		23
<b>8</b>	Tehničke karakteristike		24
	Upute i upozorenja za korisnika motoreduktorom RUN		25
	EZ izjava o sukladnosti		27

# 1) Upozorenja

Ovaj priručnik s uputama sadrži važne informacije o sigurnosti u vezi s ugradnjom: prije početka ugradnje treba pročitati sve upute. Brižljivo čuvajte ovaj priručnik i za buduće potrebe.

S obzirom na opasnosti koje mogu nastati za vrijeme ugradnje i uporabe motoreduktora RUN, ugradnja se – radi maksimalne sigurnosti – mora odvijati uz potpuno poštovanje zakona, normi i propisa. U ovom se poglavlju navode opća upozorenja; ostala važna upozorenja nalaze se u poglavljima „3.1 Prethodne provjere” i „5 Završno ispitivanje i puštanje u rad”.

**⚠ Prema najnovijem europskom zakonodavstvu, automatizacija vrata ili dvorišnih vrata uređuje se Direktivom 98/37/EZ (Direktiva o strojevima), a posebno normama: EN 13241-1 (usklađena norma), EN 12445, EN 12453 i EN 12635, koje omogućavaju izjavljivanje sukladnosti s Direktivom o strojevima.**

Daljnje informacije, smjernice za analizu rizika i izradu tehničke mape raspoloživi su na: „www.niceforyou.com”. Ovaj priručnik namijenjen je jedino tehničkom osoblju koje je kvalificirano za ugradnju. Osim specifičnog priloga „Upute i upozorenja za korisnika motoreduktorom RUN”, ni za koju se drugu informaciju koju sadrži ova knjižica može smatrati da se odnosi na krajnjeg korisnika!

- Zabranjena je uporaba motoreduktora RUN drukčija od one predviđene u ovim uputama; neodgovarajuća uporaba može izazvati opasnosti ili nanijeti štetu ljudima i stvarima.
- Prije početka ugradnje treba izraditi analizu rizika koja obuhvaća popis bitnih sigurnosnih zahtjeva predviđenih u Prilogu I Direktive o strojevima te naznačiti usvojena rješenja za njih. Podsjećamo da je analiza rizika jedan od dokumenata od kojih se sastoji tehnička mapa sustava automatizacije.
- Provjerite jesu li potrebni daljnji uređaji za dovršavanje automatizacije pomoću motoreduktora RUN na temelju specifične situacije primjene i prisutnih opasnosti; treba uzeti u obzir na primjer rizike od sudara, prignječenja, odsijecanja, preusmjerenja itd. te ostale opasnosti općenito.
- Nemojte vršiti izmjene ni na kojem dijelu ako se one ne predviđaju u ovim uputama: radnje te vrste mogu samo prouzročiti nepravilnosti u radu; NICE odbija svaku odgovornost za štetu nastalu zbog izmijenjenih proizvoda.
- Tijekom ugradnje i uporabe izbjegavajte prodiranje krutih dijelova ili tekućina u unutrašnjost kontrolne jedinice i drugih otvorenih uređaja; eventualno se obratite korisničkoj podršci NICE; uporaba motoreduktora RUN u tim situacijama može izazvati opasne situacije.
- Automatiku se ne može rabiti prije nego što bude puštena u rad kao što se navodi u poglavlju: „5 Završno ispitivanje i puštanje u rad”.
- Materijal ambalaže motoreduktora RUN treba odložiti uz potpuno poštovanje lokalnih propisa.
- U slučaju kvara koji se ne može riješiti pomoću informacija navedenih u ovom priručniku, posavjetujte se s korisničkom podrškom NICE.
- Ako dođe do interveniranja automatskih prekidača ili osigurača, prije njihovog resetiranja treba utvrditi i ukloniti kvar.
- Prije pristupanja priključnim terminalima koji se nalaze ispod poklopca motoreduktora RUN odspojite sve krugove napajanja; ako se rastavna sklopka ne može vidjeti, stavite natpis: „PAŽNJA: ODRŽAVANJE U TIJEKU”.

Posebna upozorenja o prikladnosti za uporabu ovog proizvoda u smislu Direktive 98/37/EZ o strojevima (ranija 89/392/EEZ):

- Ovaj se proizvod stavlja na tržište kao „komponenta stroja”, dakle izrađen je za ugradnju u neki stroj ili za sklapanje s drugim strojevima u cilju pravljenja „jednog stroja” u smislu Direktive 98/37/EZ samo u kombinaciji s drugim komponentama i na načine opisane u ovom priručniku s uputama. Kao što se predviđa Direktivom 98/37/EZ, upozoravamo da puštanje u rad ovog proizvoda nije dopušteno sve dok proizvođač stroja u koji se ovaj proizvod ugrađuje ne utvrdi i ne izjavi da je on u skladu s Direktivom 98/37/EZ.

Posebna upozorenja o prikladnosti za uporabu ovog proizvoda u smislu Direktive 73/23/EEZ o niskom naponu i naknadnih izmjena 93/68/EEZ:

- Ovaj proizvod udovoljava zahtjevima iz Direktive o niskom naponu ako se primjenjuje za uporabu i u konfiguracijama predviđenim u ovom priručniku s uputama i u kombinaciji s artiklima prisutnim u katalogu proizvoda tvrtke Nice S.p.A. Udovoljavanje zahtjevima možda se neće jamčiti ako se proizvod rabi u nepredviđenim konfiguracijama ili s drugim nepredviđenim proizvodima; u tim je situacijama uporaba proizvoda zabranjena sve dok izvoditelj ugradnje ne provjeri udovoljavanje zahtjevima iz direktive.

Posebna upozorenja o prikladnosti za uporabu ovog proizvoda u smislu Direktive 89/336/EEZ o elektromagnetskoj kompatibilnosti i naknadnih izmjena 92/31/EEZ i 93/68/EEZ:

- Ovaj proizvod bio je podvrgnut ispitivanjima elektromagnetske kompatibilnosti u najkritičnijim situacijama uporabe, u konfiguracijama predviđenim u ovom priručniku s uputama i u kombinaciji s artiklima prisutnim u katalogu proizvoda tvrtke Nice S.p.A. Elektromagnetska kompatibilnost možda se neće jamčiti ako se proizvod rabi u nepredviđenim konfiguracijama ili s drugim nepredviđenim proizvodima; u tim je situacijama uporaba proizvoda zabranjena sve dok izvoditelj ugradnje ne provjeri udovoljavanje zahtjevima iz direktive.

## 2) Opis proizvoda i namjena

RUN je linija nereverzibilnih elektromehaničkih motoreduktora namijenjenih automatizaciji kliznih dvorišnih vrata. Raspoložu jednom elektroničkom kontrolnom jedinicom za upravljanje i jednim konektorom tipa „SM” za prijemnik radio signala daljinskih naredbi (opcijski). Električni spojevi prema vanjskim uređajima pojednostavljeni su zahvaljujući uporabi tehnike „BlueBUS” koja omogućava spajanje više uređaja pomoću samo 2 žice. Popis uređaja koje se može spojiti na BlueBUS motoreduktora RUN nalazi se u poglavlju 7.3.1 „BlueBUS”; ažurirani popis s pripadajućim kompatibilnostima nalazi se i na: [www.niceforyou.com](http://www.niceforyou.com).

niceforyou.com.

RUN raspoložu konektorom za jedinicu za daljinsko programiranje koja omogućava potpuno i brzo upravljanje ugradnjom, održavanjem i dijagnostikom eventualnih neispravnosti u radu; vidjeti i 7.8.1 „Jedinica za daljinsko programiranje”.

Motoreduktori RUN rade pomoću električne energije; u slučaju nestanka napajanja iz električne mreže odgovarajućim ključem moguće je deblokirati i ručno pomaknuti dvorišna vrata.

U liniju RUN ubrajaju se proizvodi čije se glavne razlike opisuju u tablici 1.

**Tablica 1: usporedba bitnih karakteristika motoreduktora RUN**

Motoreduktor tipa	RUN1800	RUN1800P	RUN2500	RUN2500P
Vrsta granične sklopke	elektromehanička	blizinska, induktivna	elektromehanička	blizinska, induktivna
Maksimalna dužina krila	15 m		18 m	
Maksimalna težina krila	1800 kg		2500 kg	
Maksimalni moment pokretanja (što odgovara sili)	40 Nm (1110 N)		50 Nm (1390 N)	
Motor	Jednofazni asinkroni, maksimalno 700 W		Jednofazni asinkroni, maksimalno 870 W	

Napomena: 1 kg = 9,81 N dakle, na primjer: 1390 N = 142 kg

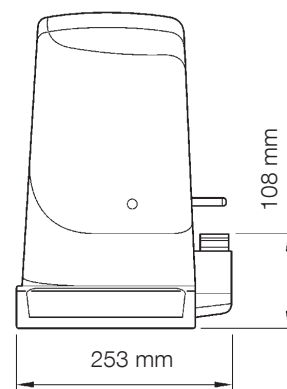
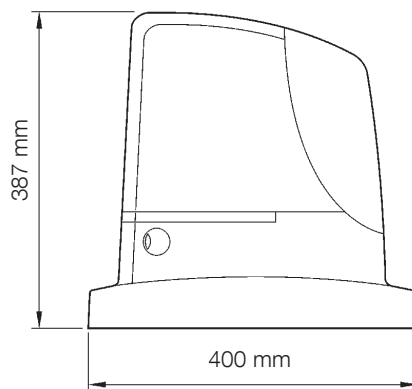
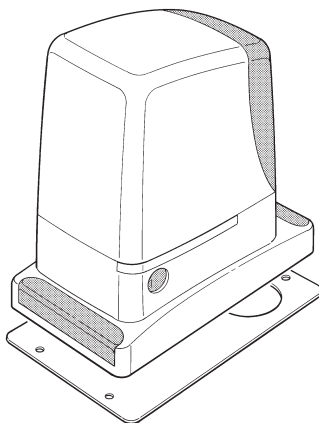

1

### 2.1) Radna ograničenja

Podaci koji se odnose na radni učinak proizvoda iz linije RUN navode se u poglavlju „8 Tehničke karakteristike” i to su jedine vrijednosti koje omogućavaju pravilnu procjenu prikladnosti za uporabu. Zbog svojih konstrukcijskih karakteristika motoreduktori RUN prikladni su za klizna krila – prema ograničenjima navedenim u tablicama 2, 3 i 4.

odredio broj ciklusa/sat i uzastopnih ciklusa treba uzeti u obzir ono što se navodi u tablicama 2 i 3.

Stvarna prikladnost motoreduktora RUN za automatiziranje određenih kliznih dvorišnih vrata ovisi o trenju i drugih pojavama – pa i povremenim, kao što je prisutnost leda koji bi mogao sprječavati kretanje krila.

Za stvarnu provjeru apsolutno je neophodno izmjeriti silu potrebnu za kretanje krila po cijeloj njegovoj putanji i kontrolirati da ona ne prelazi polovicu „nazivnog momenta” navedenog u poglavlju „8 Tehničke karakteristike” (preporučuje se 50% margine jer se uslijed nepovoljnih vremenskih uvjeta može povećati trenje); osim toga, kako bi se

**Tablica 2: ograničenja s obzirom na dužinu krila**

Dužina krila (m)	RUN1800/RUN1800P		RUN2500/RUN2500P	
	maksimalno ciklusa/sat	maksimalno uzastopnih ciklusa	maksimalno ciklusa/sat	maksimalno uzastopnih ciklusa
Do 6	42	28	42	42
6 ÷ 9	28	18	28	28
9 ÷ 12	21	14	21	21
12 ÷ 15	17	11	17	17
15 ÷ 18			14	14

**Tablica 3: ograničenja s obzirom na težinu krila**

Težina krila (kg)	RUN1800/RUN1800P	RUN2500/RUN2500P
	Postotak ciklusa	Postotak ciklusa
Do 500	100%	100%
500 ÷ 900	80	80
900 ÷ 1200	75	75
1200 ÷ 1500	60	60
1500 ÷ 1800	50	50
2000 ÷ 2300	---	40
2300 ÷ 2500	---	30

Dužina krila omogućava određivanje maksimalnog broja ciklusa po satu i uzastopnih ciklusa, dok težina omogućava određivanje postotka smanjenja u broju ciklusa, na primjer za RUN1800: ako je krilo dugo 10 m, mogući bi bili 21 ciklus/sat i 14 uzastopnih ciklusa, no ako je krilo teško 1300 kg, treba ih smanjiti na 60% pa je rezultat, dakle, oko 9 ciklusa/sat i 8 uzastopnih ciklusa. Kako bi se izbjegla pregrijavanja, kontrolna jedinica predviđa jedan ograničivač manevara koji se temelji na naprezanju motora i trajanju ciklusa te interwenira kad se premaši maksimalno ograničenje. Ograničivač manevara mjeri i temperaturu okoline pa u slučaju posebno visoke temperature još više smanjuje broj manevara.

U poglavlju „8 Tehničke karakteristike” navodi se procjena „trajnosti”, tj. prosječnog korisnog vijeka proizvoda. Na vrijednost silno utječe indeks težine manevara, tj. zbroj svih čimbenika koji doprinose trošenju. Kako biste izradili procjenu trebate zbrojiti sve indekse težine u tablici 4, zatim pomoću dobivenog rezultata provjerite procijenjenu trajnost na grafičkom prikazu. Na primjer, RUN1800 na dvorišnim vratima teškim 1300 kg, dugim 10 m, s fotočelijama i bez drugih elemenata koji ih otežavaju, ima indeks težine 45% (20+15+10). Po grafičkom prikazu procijenjena je trajnost 200.000 ciklusa.

Preciziramo da se procjena trajnosti vrši na temelju izračuna u projektu i rezultatima ispitivanja provedenih na prototipovima; budući da se radi o procjeni, ona ne predstavlja nikakvo jamstvo za stvarno trajanje proizvoda.

**Tablica 4: procjena trajnosti u odnosu na indeks težine manevara**

Indeks težine u %	RUN		Trajnost u ciklusima
	1800	2500	
<b>Težina krila u kg</b>			
Do 500	5	5	
500 ÷ 900	10	10	
900 ÷ 1200	20	20	
1200 ÷ 1500	30	30	
1500 ÷ 1800	40	40	
1800 ÷ 2200	-	50	
2200 ÷ 2500	-	60	
<b>Dužina krila u metrima</b>			
Do 6	5	5	
6 ÷ 9	10	10	
9 ÷ 12	15	15	
12 ÷ 15	25	25	
15 ÷ 18	-	35	
<b>Ostali elementi povezani s naprezanjem</b> (uzeti u obzir ako je vjerojatnost da do njih dođe veća od 10%)			
Temperatura okoline viša od 40 °C ili niža od 0 °C ili vlaga veća od 80%	10	10	
Prisutnost prašine ili pijeska	15	15	
Prisutnost soli	20	20	
Prekid manevara fotočelijom	10	10	
Prekid manevara stopom	20	20	
Aktivno pokretanje	10	10	
<b>Indeks težine ukupno u %:</b>			

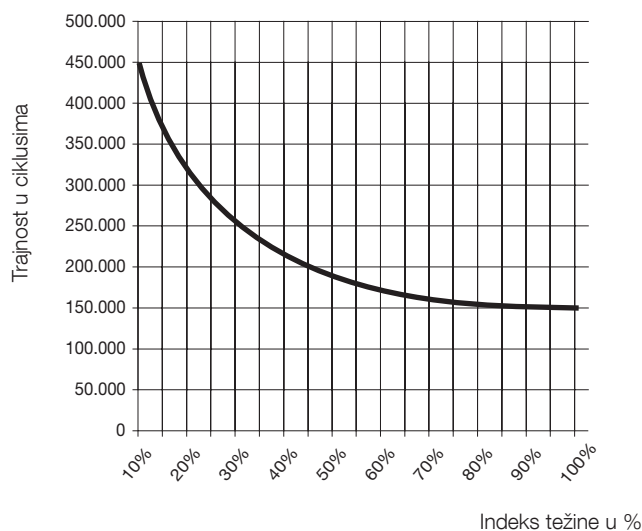

Napomena: ako indeks težine prelazi 100%, znači da su uvjeti izvan granica prihvatljivosti; savjetujemo uporabu većeg modela.

## 2.2) Tipičan sustav

Na slici 2 vidi se tipičan sustav automatizacije kliznih dvorišnih vrata motoreduktorom RUN.

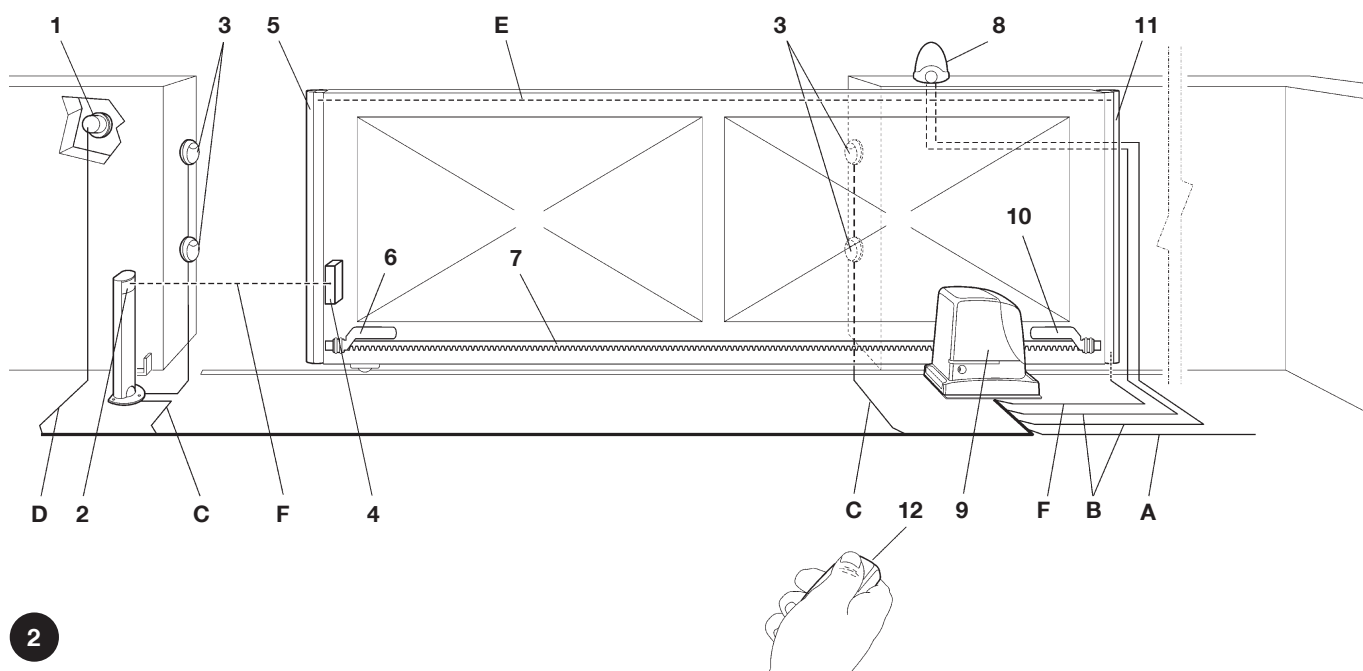

2

- |                                      |  |
|--------------------------------------|--|
| 1 Selektor s ključem                 | 7 Zupčasta letva                       |
| 2 Prijemnik FT210B                   | 8 Trepćuće svjetlo s ugrađenom antenom |
| 3 Fotočelije                         | 9 RUN                                  |
| 4 Odašiljač FT210B                   | 10 Poluga granične sklopke „Zatvoreno“ |
| 5 Primarni pomični rub               | 11 Sekundarni pomični rub (opcijski)   |
| 6 Poluga granične sklopke „Otvoreno“ | 12 Radioodašiljač                      |

## 2.3) Popis kabela

U tipičnom sustavu na slici 2 vide se i kabeli potrebni za spajanje različitih uređaja; u tablici 5 navode se karakteristike kabela.

**⚠ Korišteni kabeli moraju biti prikladni načinu ugradnje; na primjer, savjetujemo kabel tipa H03VV-F za polaganje u unutarnjim prostorima ili H07RN-F za vanjsko polaganje.**

Tablica 5: popis kabela

Spoj	Tip kabela	Maksimalna dopuštena dužina
<b>A:</b> Električni vod	1 kabel 3x1,5 mm <sup>2</sup>	30 m (napomena 1)
<b>B:</b> Trepćuće svjetlo s antenom	1 kabel 2x0,5 mm <sup>2</sup>	20 m
	1 oklopljeni kabel tipa RG58	20 m (savjetuje se manje od 5 m)
<b>C:</b> Fotočelije	1 kabel 2x0,5 mm <sup>2</sup>	30 m (napomena 2)
<b>D:</b> Selektor s ključem	2 kabela 2x0,5 mm <sup>2</sup> (napomena 3)	50 m
<b>E:</b> Spoj između 2 pomična ruba	1 kabel 2x0,5 mm <sup>2</sup> (napomena 4)	20 m
<b>F:</b> Spoj pomičnih rubova	1 kabel 2x0,5 mm <sup>2</sup> (napomena 5)	30 m

**Napomena 1:** ako je kabel za napajanje duži od 30 m, mora imati veći presjek na primjer 3x2,5 mm<sup>2</sup> i u blizini jedinice za automatizaciju treba osigurati zaštitno uzemljenje.

**Napomena 2:** ako je kabel „BLUEBUS“ duži od 30 m – do najviše 50 m, potreban je kabel 2x1 mm<sup>2</sup>.

**Napomena 3:** dva kabela 2x0,5 mm<sup>2</sup> mogu se zamijeniti samo jednim kabelom 4x0,5 mm<sup>2</sup>.

**Napomena 4:** ako ima više rubova, vidjeti preporučeni način spajanja u odlomku „7.3.2 Ulaz za STOP“.

**Napomena 5:** za spajanje pomičnih rubova na klizna krila treba rabiti odgovarajuće uređaje koji omogućavaju spajanje čak idok je krilo u pokretu; na slici se vidi uporaba fotočelije FT210B.

### 3) Ugradnja

**▲ Motoreduktor RUN treba ugraditi kvalificirano osoblje uz poštovanje zakona, normi i propisa te onoga što se navodi u ovim uputama.**

#### 3.1) Prethodne provjere

Prije početka ugradnje motoreduktora RUN morate izvršiti ove kontrole:

- Provjerite je li sav materijal koji ćete rabiti u odličnom stanju, prikladan za uporabu i u skladu s normama.
- Provjerite je li struktura dvorišnih vrata prikladna za automatiziranje.
- Provjerite jesu li težina i dimenzije krila u okviru radnih ograničenja koja se navode u poglavlju „2.1 Radna ograničenja”.
- Provjerite – uspoređujući je s vrijednostima navedenim u poglavlju „8 Tehničke karakteristike” – je li sila potrebna za stavljanje krila u pokret manja od polovice „maksimalnog momenta”, a sila potrebna za održavanje krila u pokretu manja od polovice „nazivnog momenta”; preporučuje se 50% margine za sile jer se uslijed nepovoljnih vremenskih uvjeta može povećati trenje.
- Provjerite da u cijelom hodu vrata, i pri zatvaranju i pri otvaranju, nema točaka u kojima je trenje veće.
- Provjerite da nema opasnosti od ispadanja krila iz vodilica.
- Provjerite jesu li mehanički graničnici dovoljno čvrsti i da se neće deformirati niti ako krilo silovito udari u graničnik.
- Provjerite je li krilo u ravnoteži, tj. ne smije se samo pomicati ako ga pustite u bilo kojem položaju.
- Uvjerite se da područje pričvršćenja motoreduktora nije podložno poplavlivanju; eventualno ga montirajte podignutog od tla.
- Provjerite omogućava li područje pričvršćenja motoreduktora deblokiranje te jednostavan i siguran ručni manevar.
- Provjerite jesu li točke pričvršćenja raznih uređaja u područjima zaštićenim od udaraca, a površine dovoljno solidne.

- Dijelove sustava za automatizaciju ne smije se uranjati u vodu ili druge tekućine.
- Nemojte stavljati motoreduktor RUN blizu plamena ili izvora topline, u potencijalno eksplozivnoj, prilično kiseloj ili slanoj atmosferi – to može oštetiti RUN i biti uzrokom neispravnosti u radu ili opasnih situacija.
- U slučaju da na krilu ili u području kretanja krila postoje vrata za prolaz, treba se uvjeriti da ona ne ometaju normalan hod i eventualno montirati odgovarajući sustav međublokiranja.
- Spojite kontrolnu jedinicu na električni vod koji ima zaštitno uzemljenje.
- Električni vod mora biti zaštićen prikladnim termomagnetskim prekidačem i diferencijalnom sklopkom.
- Na vod za napajanje iz električne mreže potrebno je montirati rastavnu sklopku (III kategorija prenapona, tj. s razmakom između kontakata najmanje 3,5 mm) ili drugi jednakovrijedan sustav, na primjer utičnicu i pripadajući utikač. Ako rastavna sklopka nije u blizini sustava za automatizaciju, mora postojati sustav blokade protiv nenamjernog ili neovlaštenog spajanja.

#### 3.2) Pričvršćivanje motoreduktora

Ako površina za oslonac već postoji, motoreduktor treba pričvrstiti izravno na nju odgovarajućim sredstvima, na primjer udarnim tiplama. U suprotnom, da biste pričvrstili motoreduktor:

1. Iskopajte temelje prikladnih dimenzija služeći se kao referencijom mjerama na slici 3.
2. Pripremite jedno ili više crijeva za prolaz električnih kabela, kao na slici 4.
3. Pričvrstite 4 sidrena J-vijka na temeljnu ploču stavljajući jednu maticu s donje i jednu s gornje strane ploče; maticu ispod ploče treba naviti kao na slici 5, tako da dio s navojem strši najviše 40 mm iz ploče.

4. Izlijte beton pa, prije nego što se počne stvrdnjavati, stavite temeljnu ploču po mjerama naznačenim na slici 3; provjerite je li paralelna s krilom i savršeno nivelirana, slika 6. Pričekajte dok se beton potpuno ne stvrdne.
5. Skinite 4 matice na gornjoj strani ploče pa položite na nju motoreduktor; provjerite je li savršeno paralelan s krilom, zatim malo navijte 4 dostavljene matice i podloške kao na slici 7.

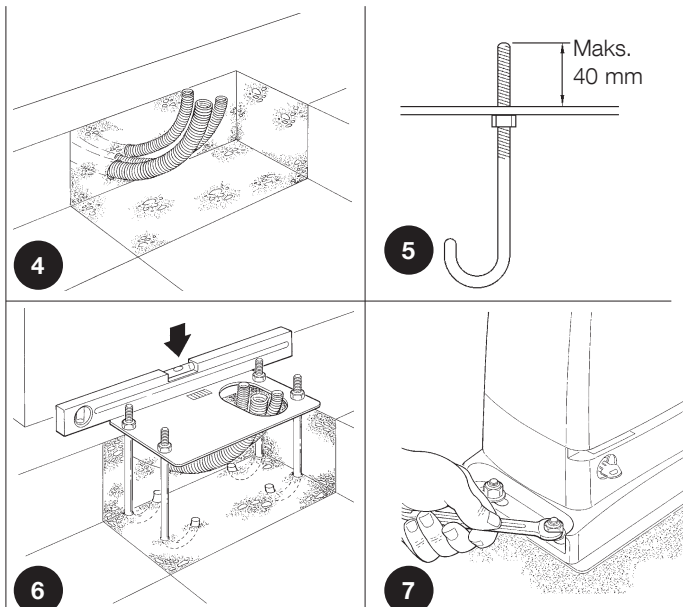
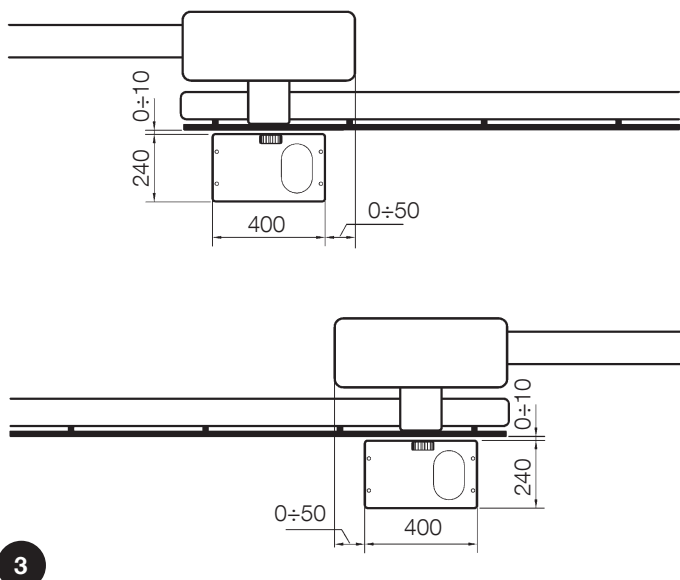

6. Deblokirajte motoreduktor kao što se navodi u odlomku „Deblokiranje i ručno pomicanje” u poglavlju „Upute i upozorenja za korisnika motoreduktorom RUN”.
7. Potpuno otvorite krilo, položite na zupčanik prvi segment zupčaste poluge i provjerite podudara li se zupčasta poluga s početkom krila kao na slici 8. Provjerite je li zračnost između zupčanika i zupčaste poluge 1÷2 mm, zatim prikladnim sredstvima pričvrstite zupčastu polugu na krilo.

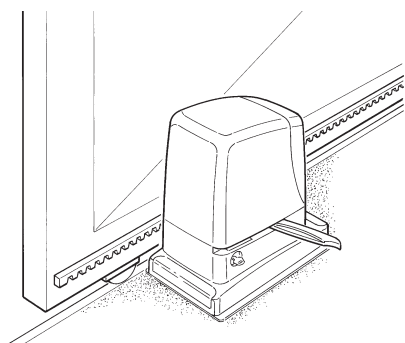

8

**⚠ Kako bi se izbjeglo da krilo svojom težinom opterećuje motoreduktor, važno je da između zupčaste poluge i zupčanika postoji zračnost od 1÷2 mm kao na slici 9.**

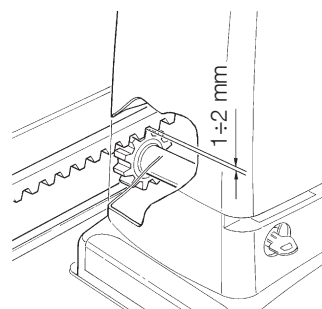

9

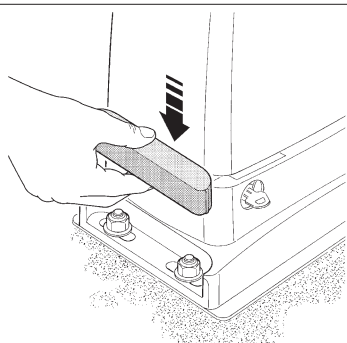

10

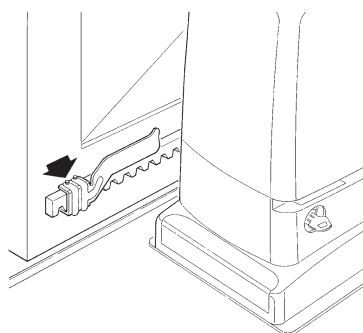

11

8. Kliznite krilo i, služeći se i dalje zupčanikom kao referencijom, pričvrstite ostale elemente zupčaste poluge.
9. Odrežite višak zupčaste poluge u krajnjem dijelu.
10. Više puta otvorite i zatvorite krilo te provjerite je li zupčasta poluga poravnata sa zupčanikom uz maksimalno odstupanje 5 mm i poštuje li se po cijeloj dužini između zupčanika i zupčaste poluge zračnost 1÷2 mm.
11. Snažno zategnite pričvršne matice motoreduktora i uvjerite se da je on dobro učvršćen za tlo; pokrijte pričvršne matice odgovarajućim čepovima kao na slici 10.
12. Pričvrstite polugu granične sklopke kao što se opisuje u nastavku (kod verzija RUN1800P i RUN2500P poluge pričvrstite kao u

odlomku „3.3 Pričvršćivanje poluge granične sklopke kod verzija s blizinskom induktivnom graničnom sklopkom”):

- Ručno dovedite krilo u otvoreni položaj ostavljajući najmanje 2-3 cm do mehaničkog graničnika.
  - Kliznite polugu po zupčastoj poluzi u smjeru otvaranja sve dok granična sklopka ne intervenira. Zatim pomaknite polugu najmanje 2 cm prema naprijed pa odgovarajućim zatičnim vijcima blokirajte polugu na zupčastoj poluzi kao na slici 11.
  - Istu radnju izvršite i za graničnu sklopku za zatvaranje.
13. Blokirajte motoreduktor kao što se navodi u odlomku „Deblokiranje i ručno pomicanje” u poglavlju „Upute i upozorenja za korisnika”.

### 3.3) Pričvršćivanje poluge granične sklopke kod verzija s blizinskom induktivnom graničnom sklopkom

Kod verzija RUN1800P i RUN2500P koje se služe blizinskom induktivnom graničnom sklopkom, polugu granične sklopke treba pričvrstiti prema opisu u nastavku.

1. Ručno dovedite krilo u otvoreni položaj ostavljajući najmanje 2-3 cm do mehaničkog graničnika.
2. Kliznite polugu po zupčastoj poluzi u smjeru otvaranja sve dok se odgovarajuća LED žaruljica ne ugasi, kao na slici 12. Zatim pomaknite polugu najmanje 2 cm prema naprijed pa odgovarajućim zatičnim vijcima blokirajte polugu na zupčastoj poluzi.
3. Ručno dovedite krilo u zatvoreni položaj ostavljajući najmanje 2-3 cm do mehaničkog graničnika.
4. Kliznite polugu po zupčastoj poluzi u smjeru zatvaranja sve dok se odgovarajuća LED žaruljica ne ugasi. Zatim pomaknite polugu najmanje 2 cm prema naprijed pa odgovarajućim zatičnim vijcima blokirajte polugu na zupčastoj poluzi.

**⚠ Udaljenost poluge kod blizinske induktivne granične sklopke treba biti između 3 i 8 mm, kao što se vidi na slici 13.**

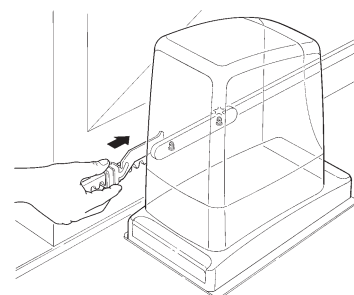

12

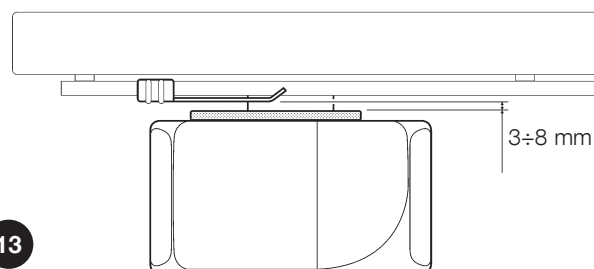

13



### 3.4) Ugradnja raznih uređaja

Ugradite druge predviđene uređaje slijedeći upute za njih. U odlomku „3.6 Opis električnih spojeva” i na slici 2 provjerite koje se uređaje može spojiti na RUN.

### 3.5) Električni spojevi

**⚠ Sve električne spojeve treba izvesti dok u sustavu nema napona.**

1. Kako biste skinuli zaštitni poklopac i pristupili elektroničkoj kontrolnoj jedinici za upravljanje motoreduktorom RUN, trebate izvaditi vijak sa strane i izvući poklopac povlačeći ga prema gore.
2. Skinite dvije gumene membrane koje zatvaraju dva otvora za prolaz kabela. Uvucite sam kabel za napajanje u manji otvor, a sve ostale kabele za razne uređaje u veći otvor. Kabele pustite 20÷30 cm duže nego što je potrebno. Vidjeti tip kabela u tablici 5 i spojeve na slici 2.
3. Obujmicom skupite i sjedinite sve kabele koji prolaze kroz veći otvor, stavljajući je malo ispod ulaznog otvora za kabele. Na većoj membrani izrežite otvor malo manji od promjera skupljenih kabela

pa navucite membranu duž kabela sve do obujmice; zatim ponovno stavite membranu u njezino sjedište. Drugom obujmicom skupite kabele odmah iznad membrane.

4. Na manjoj membrani izrežite otvor malo manji od promjera kabela za napajanje pa navucite membranu duž kabela sve dok je ponovno ne stavite u njezino sjedište.
5. Spojite kabel za napajanje iz mreže na odgovarajući priključni terminal i blokirajte ga pripadajućom stezaljkom kao što se vidi na slici 14.
6. Ostale kabele spojite prema shemi na slici 16. Radi lakšeg obavljanja te radnje priključne terminale možete izvući.
7. Na završetku spajanja obujmicama blokirajte skupljene kabele na prstene za blokiranje kabela. Višak antenskog kabela treba obujmicom učvrstiti na ostale kabele kao što se vidi na slici 15.

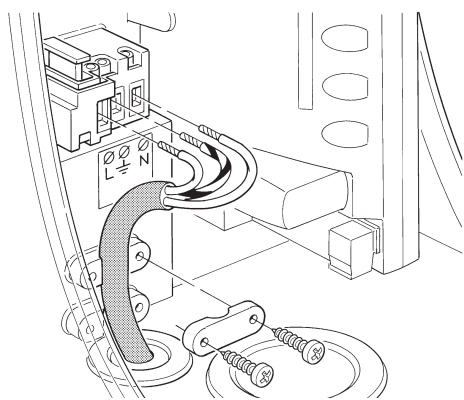

14

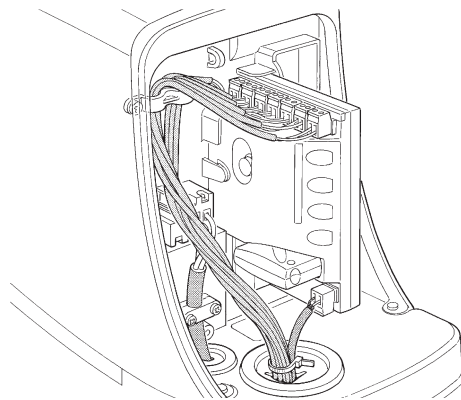

15

LUCYB

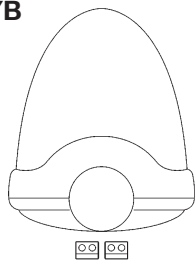

I.O.V.



MOFB

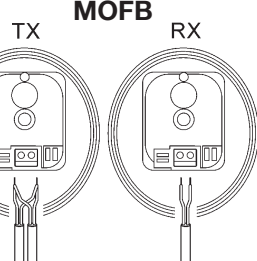

OPEN CLOSE

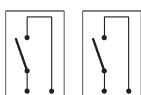

MOSE

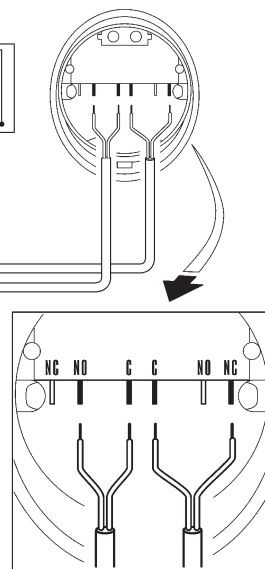

16

O spajanju 2 motora na suprotna krila vidjeti u odlomku „7.3.5 RUN u načinu rada Slave”.

### 3.6) Opis električnih spojeva

U ovom se odlomku ukratko opisuju električni spojevi; daljnje informacije pročitajte u odlomku „7.3 Dodavanje ili uklanjanje uređaja”.

**FLASH:** izlaz za jedno ili dva trepćuća svjetla tipa „LUCYB” ili slična, s jednom žaruljom 12 V, maksimalno 21 W.

**I.O.V.:** izlaz za „Indikator otvorenih vrata”; može se spojiti jednu signalnu žarulju 24 V, maksimalno 4 W. Može se programirati i za druge funkcije; vidjeti odlomak „7.2.3 Funkcije druge razine”.

**BLUEBUS:** na ovaj se priključni terminal mogu spojiti kompatibilni uređaji; svi se oni spajaju paralelno, samo dvama vodičima kojima prolaze i električno napajanje i komunikacijski signali. Ostale informacije o sustavu BlueBUS pročitajte u odlomku „7.3.1 BlueBUS”.

**STOP:** ulaz za uređaje koje blokiraju ili eventualno zaustavljaju manevar u tijeku; uz provedbu prikladnih mjera na ulaz je moguće spojiti kontakte tipa „Normalno zatvoreno”, „Normalno otvoreno” ili uređaje sa stalnim otpornikom. Ostale informacije o funkciji STOP pročitajte u odlomku „7.3.2 Ulaz za STOP”.

**KpK:** ulaz za uređaje koji upravljaju kretanjem u načinu Korak po korak; moguće je spojiti kontakte tipa „Normalno otvoreno”.

**OPEN:** ulaz za uređaje koji upravljaju pokretom samog otvaranja; moguće je spojiti kontakte tipa „Normalno otvoreno”.

**CLOSE:** ulaz za uređaje koji upravljaju pokretom samog zatvaranja; moguće je spojiti kontakte tipa „Normalno otvoreno”.

**ANTENA:** ulaz za spajanje antene za radioprijemnik (antena je ugrađena u LUCY B).

## 4) Završne provjere i pokretanje

Prije nego što počnete s fazom provjere i pokretanja automatizacije preporučljivo je staviti krilo na otprilike pola hoda kako bi se moglo slobodno kretati i pri otvaranju i pri zatvaranju.

### 4.1) Odabir smjera

Smjer manevra otvaranja treba odabrati ovisno o položaju motoreduktora u odnosu na krilo: ako se krilo mora otvarati u lijevo, selektor treba pomaknuti u lijevo kao na slici 17; ako se krilo mora otvarati u desno, selektor treba pomaknuti u desno kao na slici 18.

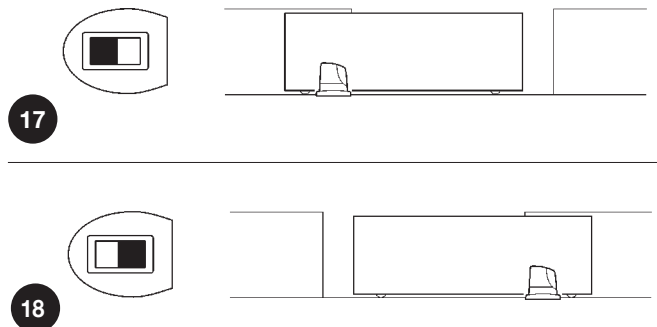

### 4.2) Priključenje napajanja

**⚠ RUN treba priključiti na napajanje iskusno i kvalificirano osoblje koje udovoljava potrebnim zahtjevima i koje će to izvesti uz potpuno poštovanje zakona, normi i propisa.**

Čim se napajanje motoreduktora RUN uključi, izvršite nekoliko jednostavnih provjera:

1. Provjerite trepće li LED za BlueBUS redovito, jednim treptajem u sekundi.
2. Provjerite trepću li i LED žaruljice na fotočelijama (i na TX i na RX); način treptanja nije važan jer ovisi o drugim čimbenicima.

3. Provjerite jesu li trepćuće svjetlo spojeno na izlaz za FLASH i indikator spojen na izlaz za I.O.V. ugašeni

Ako navedeni uvjeti nisu zadovoljeni, odmah isključite napajanje kontrolne jedinice i pažljivije kontrolirajte električne spojeve.

Ostale korisne informacije za pronalaženje kvarova i dijagnostiku pročitajte u poglavlju „7.6 Rješavanje problema”.

### 4.3) Samostalno učenje uređaja

Nakon što se priključi napajanje, kontrolna jedinica treba prepoznati uređaje spojene na ulaze za BlueBUS i STOP. Prije ove faze treptanje LED žaruljica L1 i L2 pokazuje da treba izvesti samostalno učenje uređaja.

1. Pritisnite i držite pritisnute tipke **[▲]** i **[Set]**
2. Otpustite tipke kad LED žaruljice L1 i L2 počnu vrlo brzo treptati (nakon oko 3 s)
3. Pričekajte nekoliko sekundi da kontrolna jedinica završi samostalno učenje uređaja
4. Na završetku samostalnog učenja LED žaruljica STOP mora ostati upaljena, LED žaruljice L1 i L2 će se ugaziti (eventualno će početi treptati LED žaruljice L3 i L4)

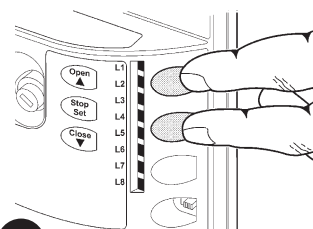

19

Fazu samostalnog učenja spojenih uređaja možete ponoviti u bilo kom trenutku, čak i nakon ugradnje, na primjer ako dodate neki uređaj; o ponovnom samostalnom učenju vidjeti u odlomku „7.3.6 Samostalno učenje drugih uređaja”.

#### 4.4) Samostalno učenje dužine krila

Nakon samostalnog učenja uređaja početak će treptati LED žaruljice L3 i L4: to znači da kontrolna jedinica mora prepoznati dužinu krila (udaljenost granične sklopke za zatvaranje od granične sklopke za otvaranje); ova je mjera potrebna za izračunavanje točaka usporavanja i točke djelomičnog otvaranja.

1. Pritisnite i držite pritisnute tipke **[▼]** i **[Set]**
2. Otpustite tipke kad manevar počne (nakon oko 3 s)
3. Provjerite je li u tijeku manevar otvaranja; u suprotnom pritisnite tipku **[Stop]** i pažljivo kontrolirajte odlomak „4.1 Odabir smjera”; zatim ponovite od točke 1.
4. Pričekajte da kontrolna jedinica dovrši manevar otvaranja sve do dostizanja granične sklopke za otvaranje; odmah nakon toga počinje manevar zatvaranja.
5. Pričekajte da kontrolna jedinica dovrši manevar zatvaranja.

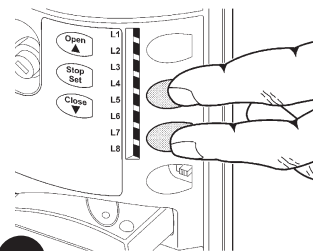

20

Ako navedeni uvjeti nisu zadovoljeni, odmah isključite napajanje kontrolne jedinice i pažljivo kontrolirajte električne spojeve. Ostale korisne informacije pročitajte u poglavlju „7.6 Rješavanje problema”.

#### 4.5) Provjera kretanja dvorišnih vrata

Nakon samostalnog učenja dužine krila savjetujemo da izvršite nekoliko manevara kako biste provjerili kreću li se dvorišna vrata pravilno.

1. Pritisnite tipku **[Open]** kako biste naredili manevar „Otvori”; provjerite odvija li se otvaranje dvorišnih vrata pravilno, bez promjena brzine; tek kad krilo bude između 70 i 50 cm od granične sklopke za otvaranje morat će usporiti i zaustaviti se, zbog interveniranja granične sklopke, 2÷3 cm od mehaničkog graničnika otvaranja.
2. Pritisnite tipku **[Close]** kako biste naredili manevar „Zatvori”; provjerite odvija li se zatvaranje dvorišnih vrata pravilno, bez promjena brzine; tek kad krilo bude između 70 i 50 cm od granične sklopke za zatvaranje morat će usporiti i zaustaviti se, zbog interveniranja granične sklopke, 2÷3 cm od mehaničkog graničnika zatvaranja.
3. Tijekom izvođenja manevara provjerite odvija li se treptanje treptućeg svjetla u razmacima 0,5 s upaljeno i 0,5 s ugašeno. Ako je tako, kontrolirajte i treptanje indikatora spojenog na priključni terminal I.O.V.: sporo treptanje pri otvaranju, brzo pri zatvaranju.
4. Više puta izvedite maneuvre otvaranja i zatvaranja kako biste se uvjerali da nema nedostataka u montaži i podešavanju ili drugih nepravilnosti kao na primjer točaka u kojima je trenje veće.
5. Provjerite jesu li motoreduktor RUN, zupčasta poluga i poluge granične sklopke solidno učvršćeni, stabilni i primjereno otporni čak i pri naglom ubrzanju ili usporenju kretanja dvorišnih vrata.

#### 4.6) Unaprijed postavljene funkcije

Kontrolna jedinica za upravljanje motoreduktorom RUN raspolaže nekim programabilnim funkcijama: one su tvornički podešene u konfiguraciji koja bi morala zadovoljiti veći dio automatizacija, no ipak ih je moguće promijeniti u svakom trenutku putem odgovarajućeg

postupka programiranja; u tu svrhu vidjeti odlomak „7.2 Programiranje”.

#### 4.7) Radioprijemnik

Kako bi se omogućilo daljinsko upravljanje motoreduktorom RUN, na kontrolnoj jedinici postoji konektor SM za opcijske radioprijemnike tipa SMXI ili SMXIS. Da biste prispojili radioprijemnik morate isključiti napajanje motoreduktora RUN i izvršiti radnju koja se vidi na slici 21. Pridruženje izlaza radioprijemnika SMXI i SMXIS naredbi koju će RUN izvršiti možete vidjeti u tablici 6:

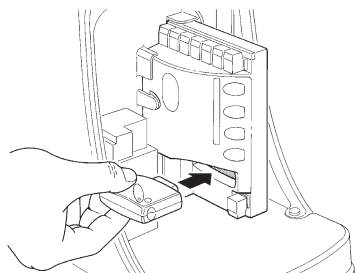

21

Daljnje informacije pogledajte u priručniku s uputama za radioprijemnik.

**Tablica 6: naredbe putem prijemnika SMXI, SMXIS**

izlaz br. 1	Naredba „KpK” (Korak po korak)
izlaz br. 2	Naredba „Djelomično otvaranje”
izlaz br. 3	Naredba „Otvori”
izlaz br. 4	Naredba „Zatvori”

### 5) Završno ispitivanje i puštanje u rad

Ovo je najvažnija faza u postupku ugradnje sustava automatizacije u smislu osiguranja maksimalne sigurnosti. Metoda završnog ispitivanja može se primjenjivati i za periodičnu provjeru uređaja u sustavu automatizacije.

**▲ Završno ispitivanje cijelog sustava mora izvršiti iskusno i kvalificirano osoblje koje će utvrditi potrebna ispitivanja s obzirom na prisutan rizik i provjeriti sukladnost sa zakonima, normama i propisima, a naročito sa svim zahtjevima norme EN 12445 koja određuje ispitne metode za strojno pogonjena vrata.**

### 5.1) Završno ispitivanje

Svaka pojedina komponenta sustava automatizacije, na primjer osjetljivi rubovi, fotočelije, zaustavljanje u slučaju opasnosti itd., zahtijeva specifičnu fazu završnog ispitivanja: za te se uređaje moraju izvršiti postupci navedeni u njihovim priručnicima s uputama. Za završno ispitivanje motoreduktora RUN izvršite sljedeći niz radnji:

1. Provjerite jesu li se u potpunosti poštovale sve upute navedene u ovom priručniku, a naročito one u poglavlju „1 Upozorenja”.
2. Deblokirajte motoreduktor kao što se navodi u odlomku „Deblokiranje i ručno pomicanje” u poglavlju „Upute i upozorenja za korisnika motoreduktorom RUN”.
3. Provjerite je li moguće ručno otvoriti i zatvoriti krilo silom koja ne prelazi 390 N (oko 40 kg).
4. Blokiranje motoreduktor.
5. Predviđenim upravljačkim napravama ili onima za zaustavljanje (selektor s ključem, upravljački gumbi ili radioodašiljači) ispitajte otvaranje, zatvaranje i zaustavljanje dvorišnih vrata te provjerite

ponašaju li se ona kako je predviđeno.

6. Provjerite, jednog po jednog, rade li svi sigurnosni uređaji u sustavu (fotočelije, osjetljivi rubovi, zaustavljanje u slučaju opasnosti itd.) pravilno te provjerite ponašaju li se dvorišna vrata kako je predviđeno. Svaki put kad neki uređaj intervenira, LED „BlueBUS” na kontrolnoj jedinici mora putem 2 brza treptaja potvrditi da kontrolna jedinica prepoznaje događaj.
7. Ako se od opasnih situacija prouzročenih kretanjem krila zaštitilo ograničavanjem sile udarca, tu je silu potrebno izmjeriti prema normi EN 12445. Ako podešavanje parametra „Osjetljivost u prepoznavanju prepreka” i kontrolu za „Moment motora” rabite kao pomoć sustavu za smanjenje sile udarca, pokušajte pronaći podešavanja kojima se dobivaju najbolji rezultati.

### 5.2) Puštanje u rad

Do puštanja u rad može doći tek nakon što su se s uspjehom izvršile sve faze završnog ispitivanja motoreduktora RUN i drugih prisutnih uređaja. Zabranjeno je djelomično ili „provizorno” puštanje u rad.

1. Pripremite i najmanje 10 godina čuvajte tehničku mapu automatizacije, koja mora sadržavati barem: nacrt cjelokupne automatizacije, shemu električnih spojeva, analizu rizika i usvojena rješenja, proizvođačevu izjavu o sukladnosti za sve korištene uređaje (za RUN rabite priloženu EZ izjava o sukladnosti), kopiju priručnika s uputama za uporabu i plan održavanja automatizacije.
2. Na dvorišna vrata pričvrstite jednu pločicu koja sadrži najmanje sljedeće podatke: tip automatizacije, naziv i adresu proizvođača (osobe odgovorne za „puštanje u rad”), serijski broj, godinu proizvodnje i oznaku „CE”.

3. Najlepnicu ili pločicu na kojoj su naznačene radnje za deblokiranje i ručni manevar pričvrstite tako da ona trajno ostane u blizini dvorišnih vrata.
4. Izradite izjavu o sukladnosti automatizacije i dostavite je vlasniku.
5. Izradite priručnik „Upute i upozorenja za uporabu automatizacije” i dostavite ga vlasniku.
6. Izradite plan održavanja automatizacije (koji mora obuhvaćati sve smjernice za održavanje pojedinih ugrađenih uređaja) i dostavite ga vlasniku.
7. Prije puštanja u rad sustava automatizacije na odgovarajući način i pismeno obavijestite vlasnika (na primjer u priručniku s uputama i upozorenjima za uporabu automatizacije) o preostalim opasnostima i rizicima.

## 6) Održavanje i odlaganje

U ovom se poglavlju navode informacije o izradi plana održavanja i odlaganju motoreduktora RUN.

### 6.1) Održavanje

Kako bi se održala stalna razina sigurnosti i jamčilo maksimalno trajanje cijele automatizacije, potrebno je redovito održavanje; u tu svrhu RUN raspolaže jednim brojačem manevara i jednim sustavom za signaliziranje potrebnog održavanja; vidjeti odlomak „7.4.4 Obavijest o potrebnom održavanju”.

**⚠ Održavanje treba obavljati uz potpuno poštovanje smjernica o sigurnosti u ovom priručniku i prema važećim zakonima i normama.**

Za druge uređaje drukčije od motoreduktora RUN slijedite njihove planove održavanja.

1. RUN zahtijeva programirano održavanje najviše svakih 6 mjeseci ili nakon najviše 30.000 manevara od prethodnog održavanja.
2. Odspojite bilo kakav izvor električnog napajanja.
3. Provjerite stanje propadanja svih materijala od kojih se automatizacija sastoji, a naročito pozornost posvetite pojavama erozije ili oksidacije konstrukcijskih dijelova; zamijenite dijelove koji su ispod potrebnog standarda.
4. Provjerite stanje istrošenosti dijelova u pokretu: zupčanik, zupčastu polugu i sve dijelove krila; zamijenite istrošene dijelove.
5. Ponovno spojite izvore električnog napajanja i izvršite sva ispitivanja i provjere iz odlomka „5.1 Završno ispitivanje”.

### 6.2) Odlaganje

Kako pri ugradnji tako i na kraju životnog vijeka ovog proizvoda radnje rastavljanja mora obaviti kvalificirano osoblje.

Ovaj se proizvod sastoji od raznih vrsta materijala: neke od njih može se reciklirati, a neke treba odložiti; informirajte se o sustavima recikliranja ili odlaganja koji se predviđaju lokalnim propisima za ovu kategoriju proizvoda.

**⚠ Pojedini dijelovi proizvoda mogu sadržavati onečišćujuće ili opasne tvari: ako ih se baci u okoliš, oni mogu izazvati štetne posljedice po okoliš i po zdravlje ljudi.**

Kako to pokazuje simbol na slici 22, ovaj proizvod zabranjeno je bacati u kućni otpad. Odložite ga odvojeno, na način koji se predviđa lokalnim propisima ili dostavite proizvod prodavatelju u trenutku kupnje novog, jednakovrijednog proizvoda.

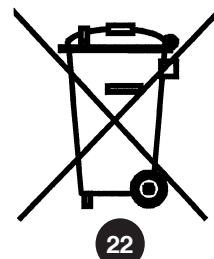

Lokalnim propisima mogu se predviđati visoke novčane kazne u slučaju nezakonitog odlaganja ovog proizvoda.

## 7) Dodatne informacije

U ovom se poglavlju govori o mogućnostima programiranja, personalizacije, dijagnostike i pronalaženja kvarova na motoreduktoru RUN.

### 7.1) Tipke za programiranje

Na kontrolnoj jedinici za RUN postoje 3 tipke koje omogućavaju i upravljanje kontrolnom jedinicom tijekom ispitivanja i programiranje:

<b>Open</b> ▲	Tipka „OPEN” omogućava upravljanje otvaranjem dvorišnih vrata ili premještanje točke programiranja prema gore
<b>Stop Set</b>	Tipka „STOP” omogućava zaustavljanje manevara; ako je držite pritisnute dulje od 5 sekundi, omogućava ulazak u programiranje
<b>Close</b> ▼	Tipka „CLOSE” omogućava upravljanje zatvaranjem dvorišnih vrata ili premještanje točke programiranja prema dolje

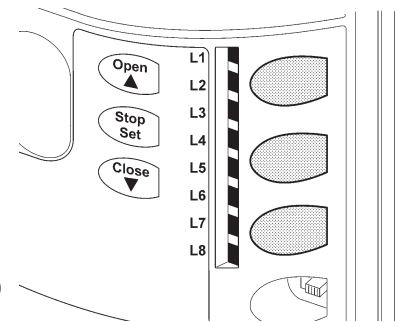

23

### 7.2) Programiranje

Na kontrolnoj jedinici za RUN raspoložive su neke programabilne funkcije koje podešavate pomoću 3 tipke na samoj kontrolnoj jedinici:

**[▲] [Set] [▼]** a prikazuju se putem 8 LED žaruljica: **L1...L8**.

Raspoložive programabilne funkcije za RUN raspoređene su na 2 razine:

**Prva razina:** funkcije podešive u načinu UKLJUČENO-ISKLJUČENO (aktivno ili nije aktivno); u tom slučaju svaka LED žaruljica

**L1...L8** pokazuje jednu funkciju; ako je upaljena, funkcija je aktivna, ako je ugašena, funkcija nije aktivna; vidjeti tablicu 7.

**Druga razina:** parametri podešivi po jednoj ljestvici vrijednosti (od 1 do 8); u tom slučaju svaka LED žaruljica **L1...L8** pokazuje koja je od 8 mogućih vrijednost podešena; vidjeti tablicu 9.

### 7.2.1) Funkcije prve razine (funkcije UKLJUČENO-ISKLJUČENO)





Tablica 7: popis programabilnih funkcija prve razine

LED	Funkcija	Opis
L1	Automatsko zatvaranje	Ova funkcija omogućava automatsko zatvaranje dvorišnih vrata nakon programiranog vremena stanke; Vrijeme stanke tvornički je postavljeno na 30 sekundi, no možete ga promijeniti na 5, 15, 30, 45, 60, 80, 120 i 180 sekundi. Ako funkcija nije aktivirana, rad je „poluautomatski”.
L2	Ponovno zatvori nakon fotočelije	Ova funkcija omogućava držanje otvorenih vrata samo onoliko vremena koliko je potrebno za prolazak; naime, „Foto” uvijek izaziva ponovno automatsko zatvaranje uz vrijeme stanke od 5 s (bez obzira na programiranu vrijednost) Ponašanje se mijenja ovisno o tome je li ili nije aktivna funkcija „Automatsko zatvaranje”. <b>Kad „Automatsko zatvaranje” nije aktivno:</b> dvorišna vrata uvijek dostižu potpuno otvoreni položaj (čak i ako se fotočelija prije oslobodi). Oslobođanje fotočelije izaziva ponovno automatsko zatvaranje uz stanku od 5 s. <b>Kad je „Automatsko zatvaranje” aktivno:</b> manevar otvaranja zaustavlja se odmah nakon oslobađanja fotočelija i dolazi do ponovnog automatskog zatvaranja uz stanku od 5 s. Funkcija „Ponovno zatvori nakon fotočelije” uvijek je onemogućena u manevrima prekinutim naredbom Stop. Ako funkcija „Ponovno zatvori nakon fotočelije” nije aktivna, vrijeme stanke bit će ono programirano ili neće doći do ponovnog automatskog zatvaranja ako funkcija nije aktivna.
L3	Uvijek zatvori	Funkcija „Uvijek zatvori” intervenira izazivajući zatvaranje ako se, kad se napajanje ponovno uspostavi, detektira da su dvorišna vrata otvorena. Iz sigurnosnih razloga manevaru prethodi 5 s prethodnog treptanja. Ako funkcija nije aktivna, kad se napajanje ponovno uspostavi dvorišna vrata ostaju zaustavljena.
L4	Usporavanje	Pri aktiviranju ove funkcije na kraju manevara otvaranja i zatvaranja umeće se faza usporavanja. Brzina usporavanja odgovara otprilike 60% nazivne brzine. <b>Pažnja:</b> motor tijekom usporavanja razvija samo pola nazivnog momenta; usporavanje se neće moći primijeniti kod teških dvorišnih vrata ili onih koja zahtijevaju maksimalni moment. Ako usporavanje nije aktivno, brzina će ostati stalna tijekom cijelog manevara.
L5	Pokretanje	Pri aktiviranju ove funkcije, na početku svakog manevara onemogućava se postupno ubrzanje, čime se postiže maksimalna sila pokretanja; korisno je tamo gdje postoje visoke razine statičkog trenja, na primjer u slučaju da snijeg ili led blokiraju krilo. Ako pokretanje nije aktivno, manevar počinje postupnim ubrzanjem.
L6	Prethodno treptanje	Funkcijom prethodnog treptanja dodaje se jedna stanika od 3 s između uključivanja treptućeg svjetla i početka manevara kako bi se unaprijed upozorilo na opasnu situaciju. Ako prethodno treptanje nije aktivno, treptuće svjetlo uključuje se na početku manevara.
L7	„Zatvori” postaje „Otvori djelomično”	Pri aktiviranju ove funkcije sve naredbe „zatvori” (ulaz za „CLOSE” ili radijska naredba „zatvori”) aktiviraju manevar djelomičnog otvaranja (vidjeti LED L6 u tablici 9).
L8	Način rada „Slave” (podređeni)	Pri aktiviranju ove funkcije RUN postaje „Slave” (podređeni): tako se može sinkronizirati rad 2 motora na suprotnim krilima na kojima jedan motor radi kao „Master” (nadređeni), a drugi kao „Slave”; više detalja vidjeti u odlomku „7.3.5 RUN u načinu rada Slave”.

Tijekom normalnog rada motoreduktora RUN, LED žaruljice **L1...L8** bit će upaljene ili ugašene ovisno o statusu funkcije koju predstavljaju, na primjer **L1** upaljena je ako je aktivno „Automatsko zatvaranje”.

### 7.2.2 Programiranje prve razine (funkcije UKLJUČENO-ISKLJUČENO)

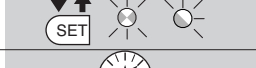
Sve funkcije prve razine tvornički su postavljene na „ISKLJUČENO”, no možete ih u svakom trenutku promijeniti kao što se vidi u tablici 8. Postupak pažljivo izvedite jer postoji maksimalno vrijeme: imate najviše 10 s od pritiska jedne tipke do pritiska druge, inače se postupak automatski završava i pohranjuju se izmjene izvršene do tog trenutka.

Tablica 8: mijenjanje funkcija UKLJUČENO-ISKLJUČENO		Primjer
1.	Pritisnite i držite pritisnutu tipku <b>[Set]</b> oko 3 s	
2.	Otpustite tipku <b>[Set]</b> kad LED L1 počne treptati	
3.	Pritisnite tipke <b>[▲]</b> ili <b>[▼]</b> kako bi se treptanje premjestilo na LED koji predstavlja funkciju za izmjenu	
4.	Pritisnite tipku <b>[Set]</b> kako biste promijenili status funkcije (kratko treptanje = ISKLJUČENO; dugo treptanje = UKLJUČENO)	
5.	Pričekajte 10 s prije izlaska iz programiranja, dok ne istekne maksimalno vrijeme.	

Napomena: u jednoj te istoj fazi programiranja točke 3 i 4 možete ponoviti kako biste druge funkcije stavili na UKLJUČENO ili ISKLJUČENO.

### 7.2.3 Funkcije druge razine (podesivi parametri)

Tablica 9: popis programabilnih funkcija druge razine				
Ulazni LED	Parametar	LED (razina)	Vrijednost	Opis
L1	Vrijeme Stanka	L1	5 sekundi	Podešava vrijeme stanke tj. vrijeme prije ponovnog automatskog zatvaranja. Učinkovito je samo ako je aktivno automatsko zatvaranje.
		L2	15 sekundi	
		L3	30 sekundi	
		L4	45 sekundi	
		L5	60 sekundi	
		L6	80 sekundi	
		L7	120 sekundi	
		L8	180 sekundi	
L2	Funkcija KpK	L1	Otvori – Stop – Zatvori – Stop	Podešava sekvencu naredbi pridruženih ulazu za KpK ili 1. radijskoj naredbi.
		L2	Otvori – Stop – Zatvori – Otvori	
		L3	Otvori – Zatvori – Otvori – Zatvori	
		L4	Stambena zgrada	
		L5	Stambena zgrada 2 (više od 2" izaziva stop)	
		L6	Korak po korak 2 (manje od 2" izaziva djelomično otvaranje)	
		L7	Prisutna osoba	
		L8	Otvaranje u „poluautomatskom” načinu, zatvaranje u načinu „Prisutna osoba”	
L3	Osjetljivost u prepoznavanju prepreka	L1	Iznimno visoka osjetljivost (lagana vrata)	Podešava osjetljivost u prepoznavanju prepreka. Pazite jer na osjetljivost utječe i sila motora (vidjeti L5); silu motora treba uvijek prvu podesiti, tek nakon toga moći ćete podesiti osjetljivost u prepoznavanju prepreka.
		L2	Vrlo visoka osjetljivost	
		L3	Visoka osjetljivost	
		L4	Srednja osjetljivost	
		L5	Srednje niska osjetljivost	
		L6	Niska osjetljivost	
		L7	Vrlo niska osjetljivost	
		L8	Iznimno niska osjetljivost (teška vrata)	
L4	Izlaz I.O.V.	L1	Funkcija „Indikator otvorenih vrata”	Podešava funkciju pridruženu izlazu za I.O.V. (bez obzira na to koja je funkcija pridružena izlazu, kad je aktivna napaja naponom 24 V -30 +50% uz maksimalnu snagu 4 W).
		L2	Aktivna ako je krilo zatvoreno	
		L3	Aktivna ako je krilo otvoreno	
		L4	Aktivna s izlazom br. 2 radiosignala	
		L5	Aktivna s izlazom br. 3 radiosignala	
		L6	Aktivna s izlazom br. 4 radiosignala	
		L7	Indikator održavanja	
		L8	Električna brava	
L5	Kontrola momenta motora	L1	Postavljeno na 40%	Nakon pokretanja motora podešava silu kako bi je prilagodila težini dvorišnih vrata. Kontrolni sustav mjeri i temperaturu okoline pa u slučaju posebno niskih temperatura automatski povećava silu.
		L2	Postavljeno na 50%	
		L3	Postavljeno na 60%	
		L4	Postavljeno na 80%	
		L5	Postavljeno na 100%	
		L6	Poluautomatski 1 = 40÷100% (1)	
		L7	Poluautomatski 2 = 60÷100% (1)	
		L8	Automatski = 0÷100% (2)	

Ulazni LED	Parametar	LED (razina)	Vrijednost	Opis
L6	Otvori djelomično	L1	0,5 m	Podešava mjeru djelomičnog otvaranja. Djelomično otvaranje može se narediti putem 2. radijske naredbe ili pomoću „ZATVORI”; ako je prisutna, funkcija „Zatvori” postaje „Otvori djelomično”.
		L2	1 m	
		L3	1,5 m	
		L4	2 m	
		L5	2,5 m	
		L6	3 m	
		L7	3,4 m	
		L8	4 m	
L7	Obavijest o potrebnom održavanju	L1	Automatski (na temelju težine manevara)	Podešava broj manevara nakon kojeg treba signalizirati zahtjev za održavanje automatizacije (vidjeti odlomak „7.4.4 Obavijest o potrebnom održavanju”).
		L2	2000	
		L3	4000	
		L4	7000	
		L5	10.000	
		L6	15.000	
		L7	20.000	
		L8	30.000	
L8	Popis nepravilnosti	L1	Rezultat 1. manevara (posljednjeg izvedenog)	Omogućava provjeravanje do koje je vrste nepravilnosti došlo u posljednjih 8 manevara (vidjeti odlomak „7.6.1 Povijest nepravilnosti”).
		L2	Rezultat 2. manevara	
		L3	Rezultat 3. manevara	
		L4	Rezultat 4. manevara	
		L5	Rezultat 5. manevara	
		L6	Rezultat 6. manevara	
		L7	Rezultat 7. manevara	
		L8	Rezultat 8. manevara	

Napomena: „” predstavlja tvorničku postavku

Napomena (1): automatski podešava potrebnu silu održavajući minimalnu jamčenu razinu sile.













Napomena (2): automatski podešava potrebnu silu.

Sve se parametre može podesiti po želji bez ikakve negativne posljedice; samo bi podešavanja funkcija „Osjetljivost u prepoznavanju prepreka” i „Kontrola sile motora” mogla zahtijevati posebnu pažnju:

- Ne preporučuje se uporaba visokih vrijednosti sile za kompenziranje nepravilnosti u točkama trenja krila: pretjerana sila može ugroziti rad sigurnosnog sustava ili oštetiti krilo.
- Ako „Osjetljivost u prepoznavanju prepreka” rabite kao pomoć sustavu za smanjenje sile udarca, nakon svakog podešavanja ponovno izmjerite silu prema normi EN 12445.
- Istrošenost i atmosferski uvjeti utječu na kretanje dvorišnih vrata: silu treba periodično kontrolirati i ponovno je podesiti.

#### 7.2.4) Programiranje druge razine (podesivi parametri)











Podesivi parametri tvornički su postavljeni kako je u tablici 9 istaknuto s: „”, no možete ih u svakom trenutku promijeniti kao što se vidi u tablici br. 10. Postupak pažljivo izvedite jer postoji maksimalno vrijeme: imate najviše 10 s od pritiska jedne tipke do pritiska druge, inače se postupak automatski završava i pohranjuju se izmjene izvršene do tog trenutka.

Tablica 10: mijenjanje podesivih parametara	Primjer
1. Pritisnite i držite pritisnutu tipku <b>[Set]</b> oko 3 s	 3 s
2. Otpustite tipku <b>[Set]</b> kad LED L1 počne treptati	 L1 
3. Pritisnite tipke <b>[▲]</b> ili <b>[▼]</b> kako bi se treptanje premjestilo na „Ulazni LED” koji predstavlja parametar za izmjenu	 ili  
4. Pritisnite i zadržite pritisnutu tipku <b>[Set]</b> ; tipku <b>[Set]</b> treba zadržati pritisnutu za vrijeme vršenja koraka 5 i 6	
5. Pričekajte oko 3 s, nakon čega će se upaliti LED koji predstavlja trenutnačnu razinu parametra za izmjenu	
6. Pritisnite tipke <b>[▲]</b> ili <b>[▼]</b> kako biste premjestili LED koji predstavlja vrijednost parametra.	 ili  
7. Otpustite tipku <b>[Set]</b>	
8. Pričekajte 10 s prije izlaska iz programiranja, dok ne istekne maksimalno vrijeme.	 10 s

Napomena: u jednoj te istoj fazi programiranja, točke od 3 do 7 možete ponoviti kako biste podesili više parametara.

## 7.2.5 Primjer programiranja prve razine (funkcije UKLJUČENO-ISKLJUČENO)





















Kao primjer navodimo niz radnji kojima možete promijeniti tvorničke postavke funkcija „Automatsko zatvaranje” (L1) i „Uvijek zatvori” (L3).

Tablica 11: primjer za programiranje prve razine		Primjer
1.	Pritisnite i držite pritisnutu tipku <b>[Set]</b> oko 3 s	 3 s
2.	Otpustite tipku <b>[Set]</b> kad LED L1 počne treptati	 L1 
3.	Jednom pritisnite tipku <b>[Set]</b> kako biste promijenili status funkcije pridružene LED žaruljici L1 (Automatsko zatvaranje); sad će LED L1 treptati dugim treptajima	  L1
4.	Pritisnite 2 puta tipku <b>[▼]</b> kako bi se treptanje premjestilo na LED L3	   L3
5.	Jednom pritisnite tipku <b>[Set]</b> kako biste promijenili status funkcije pridružene LED žaruljici L3 (Uvijek zatvori); sad će LED L3 treptati dugim treptajima	  L3
6.	Pričekajte 10 s prije izlaska iz programiranja, dok ne istekne maksimalno vrijeme.	 10 s

Na završetku ovih radnji LED žaruljice L1 i L3 moraju ostati upaljene kako bi pokazivale da su funkcije „Automatsko zatvaranje” i „Uvijek zatvori” aktivne.

## 7.2.6 Primjer za programiranje druge razine (podesivi parametri)

Kao primjer navodimo niz radnji kojima možete promijeniti tvorničke postavke parametara i povećati „Vrijeme stanke” na 60 s (ulaz na L1 i razina na L5) te smanjiti „Kontrolu momenta” na 60% (ulaz na L5 i razina na L3).

Tablica 12: primjer za programiranje druge razine		Primjer
1.	Pritisnite i držite pritisnutu tipku <b>[Set]</b> oko 3 s	 3 s
2.	Otpustite tipku <b>[Set]</b> kad LED L1 počne treptati	 L1 
3.	Pritisnite i zadržite pritisnutu tipku <b>[Set]</b> ; tipku <b>[Set]</b> treba zadržati pritisnutu za vrijeme vršenja koraka 4 i 5	
4.	Pričekajte oko 3 s dok se ne upali LED L3 koji predstavlja trenutnu razinu za „Vrijeme stanke”	 L3 3 s
5.	Pritisnite 2 puta tipku <b>[▼]</b> kako bi se upaljeni LED premjestio na L5 koji predstavlja novu vrijednost za „Vrijeme stanke”	   L5
6.	Otpustite tipku <b>[Set]</b>	
7.	Pritisnite 4 puta tipku <b>[▼]</b> kako bi se treptanje premjestilo na LED L5	     L5
8.	Pritisnite i zadržite pritisnutu tipku <b>[Set]</b> ; tipku <b>[Set]</b> treba zadržati pritisnutu za vrijeme vršenja koraka 9 i 10	
9.	Pričekajte oko 3 s sve dok se ne upali LED L5 koji predstavlja trenutnu razinu kontrole za „Moment motora”	3 s  L5
10.	Pritisnite 2 puta tipku <b>[▲]</b> kako bi se upaljeni LED premjestio na L3 koji predstavlja novu vrijednost	   L3
11.	Otpustite tipku <b>[Set]</b>	
12.	Pričekajte 10 s prije izlaska iz programiranja, dok ne istekne maksimalno vrijeme.	 10 s

## 7.3) Dodavanje ili uklanjanje uređaja

Sustavu automatizacije RUN možete u svakom trenutku dodati uređaje ili ih ukloniti iz njega. Posebno se na „BlueBUS” i na ulaz za „STOP” mogu spojiti razne vrste uređaja kao što se navodi u odlomcima koji slijede.

**Nakon dodavanja ili uklanjanja uređaja treba ponoviti samostalno učenje uređaja kao što se opisuje u odlomku „7.3.6 Samostalno učenje drugih uređaja”.**

### 7.3.1) BlueBUS

Tehnologija BlueBUS omogućava spajanje kompatibilnih uređaja putem samo dva vodiča kojima prolaze i električno napajanje i komunikacijski signali. Sve se uređaje spaja paralelno na 2 vodiča BlueBUS, pri čemu nije potrebno poštovati polaritet; svaki se uređaj pojedinačno prepoznaje jer mu se tijekom instaliranja dodjeljuje jednoznačna adresa. Na BlueBUS mogu se spojiti na primjer: fotoćelije, sigurnosni uređaji, upravljački gumbi, signalna svjetla itd. Kontrolna jedinica za RUN prikladnim procesom samostalnog

učenja pojedinačno prepoznaje sve spojene uređaje i iznimno precizno može otkriti sve moguće nepravilnosti. Iz tog razloga svaki put kad se dodaje ili uklanja neki uređaj spojen na BlueBUS, na kontrolnoj jedinici treba izvršiti samostalno učenje kao što se opisuje u odlomku „7.3.6 Samostalno učenje drugih uređaja”.



### 7.3.2) Ulaz za STOP

STOP je ulaz koji izaziva hitno zaustavljanje manevra s kratkom promjenom smjera. Na taj se ulaz može spojiti uređaje kojima je izlaz normalno otvoren („NO“) kontakt, normalno zatvoren („NZ“) kontakt ili uređaje s izlazom na stalni otpornik 8,2 k $\Omega$ , na primjer osjetljivi rubovi. Kao i za BlueBUS, kontrolna jedinica u fazi samostalnog učenja prepoznaje vrstu uređaja spojenog na ulaz za STOP (vidjeti odlomak „7.3.6 Samostalno učenje drugih uređaja“); nakon toga izaziva STOP kad dođe do bilo kakve promjene u naučenom statusu.

Uz odgovarajuće mjere na ulaz za STOP možete spojiti i više uređaja, čak i različite vrste:

- Bilo koji broj uređaja NO možete međusobno paralelno spojiti.
- Bilo koji broj uređaja NZ možete međusobno serijski spojiti.
- Dva uređaja s izlazom na stalni otpornik 8,2 k $\Omega$  možete paralelno spojiti; ako postoji više od 2 uređaja, onda ih sve morate spojiti „u kaskadi“, sa samo jednim završnim otpornikom 8,2 k $\Omega$ .

- NO i NZ možete kombinirati stavljanjem 2 kontakata paralelno, pažeći da na kontakt NZ serijski ugradite otpornik 8,2k  $\Omega$  (to omogućava kombinaciju 3 uređaja: NO, NZ i 8,2 k $\Omega$ ).

**⚠ Ako ulaz za STOP rabite za spajanje uređaja sa sigurnosnim funkcijama; samo uređaji s izlazom na stalni otpornik 8,2 k $\Omega$  jamče kategoriju 3 sigurnosti u slučaju kvara prema normi EN 954-1.**

### 7.3.3) Fotočelije

Adresiranjem putem odgovarajućih prenosnika sustav „BlueBUS“ omogućava kontrolnoj jedinici prepoznavanje fotočelija i dodjeljivanje točne funkcije detektiranja. Adresiranje treba izvršiti i na TX i na RX (stavljanjem prenosnika na isti način), provjeravajući da ne postoje drugi parovi fotočelija s istom adresom.

Kod automatizacije kliznih dvorišnih vrata, RUN omogućava ugradnju fotočelija kao što se vidi na slici 24.

Nakon ugradnje ili uklanjanja fotočelija kontrolna jedinica mora izvršiti samostalno učenje kao što se opisuje u odlomku „7.3.6 Samostalno učenje drugih uređaja“.

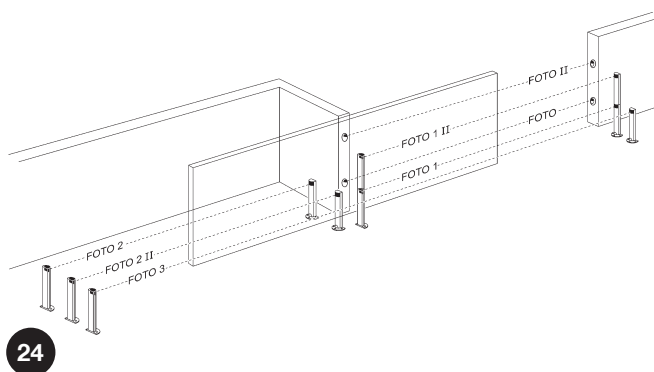

24

**Tablica 13: adrese fotočelija**

Fotočelija	Prenosnici	Fotočelija	Prenosnici
<b>FOTO (FOTOČELIJA)</b> Vanjska fotočelija h = 50 intervenira pri zatvaranju		<b>FOTO 2</b> Vanjska fotočelija intervenira pri otvaranju	
<b>FOTO II</b> Vanjska fotočelija h = 100 intervenira pri zatvaranju		<b>FOTO 2 II</b> Unutarnja fotočelija intervenira pri otvaranju	
<b>FOTO 1</b> Unutarnja fotočelija h = 50 intervenira pri zatvaranju		<b>FOTO 3</b> Jedinstvena fotočelija za cijeli sustav automatizacije	
<b>FOTO 1 II</b> Unutarnja fotočelija h = 100 intervenira pri zatvaranju		<b>⚠</b> Kad se FOTO 3 ugrađuje zajedno s FOTO II, položaj elemenata fotočelije (TX – RX) mora biti u skladu s upozorenjima iz priručnika s uputama za fotočelije.	

### 7.3.4) Fotosenzor FT210B

Fotosenzor FT210B kombinira sustav ograničenja sile (tipa C prema normi EN 12453) i detektor prisutnosti koji otkriva prepreke prisutne po optičkoj osi između odašiljača TX i prijemnika RX (tipa D prema normi EN 12453). Signali statusa osjetljivog ruba na fotosenzoru FT210B odašilju se putem svjetlosnih zraka fotočelije, čime se 2 sustava sjedinjuju u jedan jedini uređaj. Odašiljački dio nalazi se na pomičnom krilu i napaja se baterijama, tako da nema ružnih sustava spajanja; posebni krugovi smanjuju trošenje baterije kao bi se jamčilo trajanje do 15 godina (vidjeti detalje procjene u uputama za proizvod). Samo jedan uređaj FT210B u kombinaciji s jednim osjetljivim rubom (na primjer TCB65) omogućava dostizanje razine sigurnosti „primarnog ruba“ koja se zahtijeva normom EN 12453 za sve „vrste uporabe“ i „vrste aktiviranja“.

Fotosenzor FT210B u kombinaciji s „otpornim“ (8,2 k $\Omega$ ) osjetljivim rubovima, siguran je u slučaju pojedinačnog kvara (kategorija 3 prema EN 954-1). Raspolaže posebnim krugom protiv sudara, koji sprječava interferencije s drugim detektorima – čak iako nisu sinkronizirani – i omogućava dodavanje drugih fotočelija; na primjer, u slučaju prolaska teških vozila gdje se obično na 1 m od tla stavlja drugu fotočeliju.

Daljnje informacije o načinima spajanja i adresiranja vidjeti u priručniku s uputama za FT210B.

### 7.3.5) RUN u načinu rada „Slave”

Kad je prikladno programiran i spojen, RUN može raditi u načinu „Slave” (podređeni); ovaj način rada služi kad treba automatizirati 2 suprotna krila i želi se da njihovo kretanje bude sinkronizirano. Na taj način jedan motoreduktor RUN radi kao Master (nadređeni) tj. naređuje manevre, dok drugi RUN radi kao Slave, tj. vrši naredbe koje šalje Master (tvornički su svi motoreduktori RUN Master).

Da biste RUN konfigurirali kao Slave morate aktivirati funkciju prve razine „Način Slave” (vidjeti tablicu 7).

RUN Master i RUN Slave spajaju se putem sustava BlueBUS.

**⚠ U ovom slučaju treba poštovati polaritet u spoju između dva motoreduktora RUN kao što se vidi na slici 26 (ostali uređaji ostaju bez polariteta).**

Kako biste ugradili 2 motoreduktora RUN u načinu rada Master i Slave izvršite sljedeće radnje:

- Ugradite 2 motora kao što se vidi na slici 25. Nije važno koji motor radi kao Master, a koji kao Slave: u izboru treba voditi računa o pogodnosti spojeva i o činjenici da naredba Korak po korak na motoru Slave omogućava potpuno otvaranje samo krila Slave.

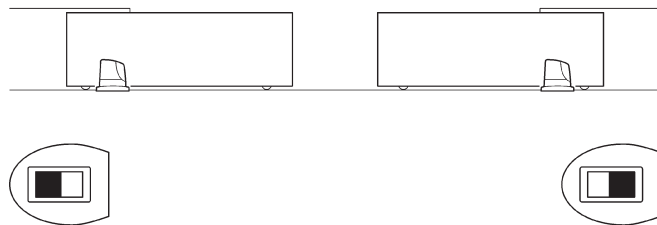

25

- Spojite 2 motora kao na slici 26.
- Odaberite smjer manevra otvaranja 2 motora kao što se navodi u odlomku „4.1 Odabir smjera”.
- Uključite napajanje 2 motora.
- Na motoreduktoru RUN Slave programirajte funkciju „Način Slave” (vidjeti tablicu 7).
- Izvedite dobavljanje uređaja na motoreduktoru RUN Slave (vidjeti odlomak „4.3 Samostalno učenje uređaja”).
- Izvedite dobavljanje uređaja na motoreduktoru RUN Master (vidjeti odlomak „4.3 Samostalno učenje uređaja”).
- Izvedite dobavljanje dužine krila na motoreduktoru RUN Master (vidjeti odlomak „4.4 Samostalno učenje dužine krila”).

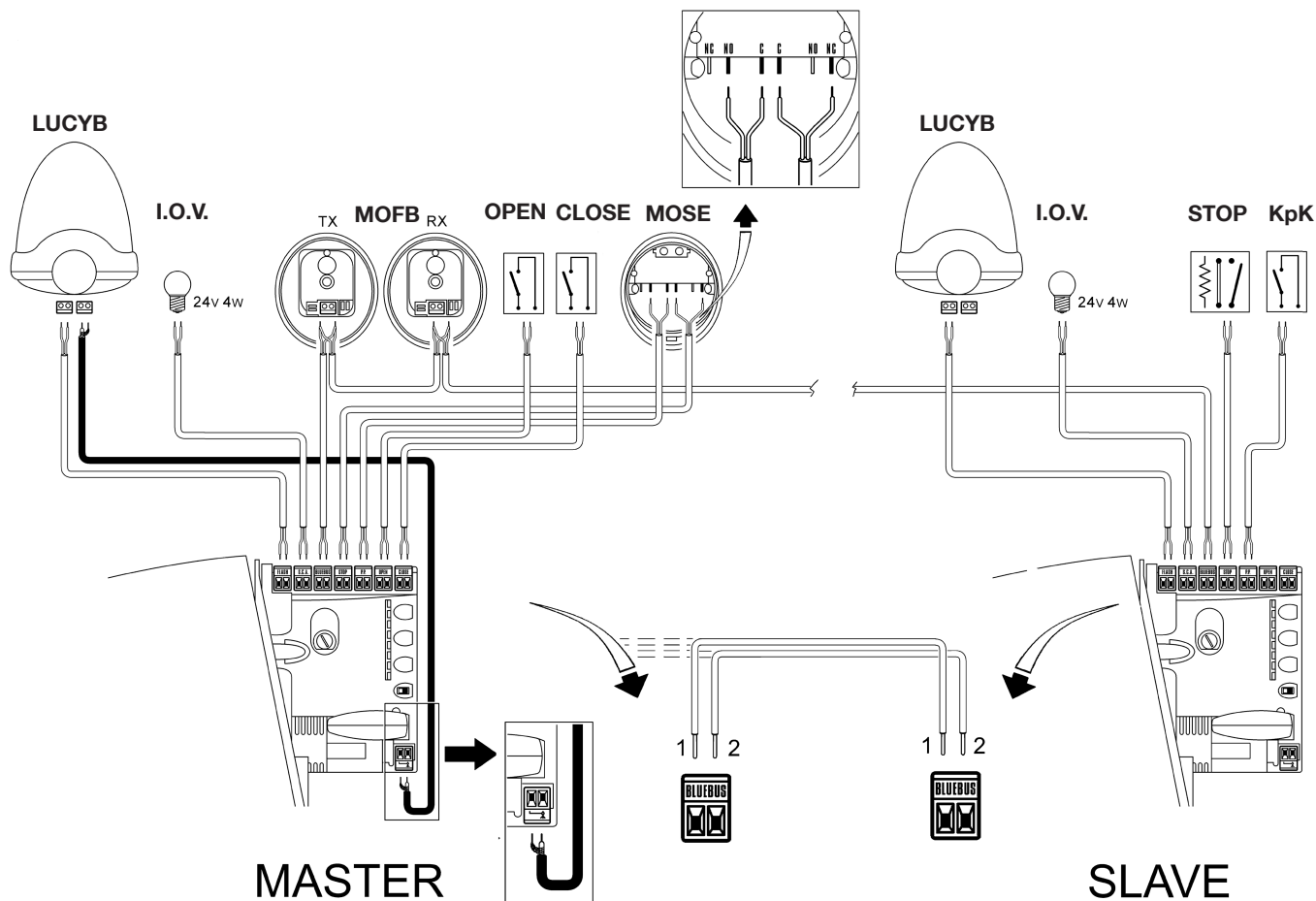

26

Pri spajanju 2 motoreduktora RUN u načinu rada Master-Slave pazite na sljedeće:

- svi uređaji moraju biti spojeni na RUN Master (kao na sl. 26), uključujući i radioprijemnik
- svako se programiranje na motoreduktoru RUN Slave zanemaruje (prevladava ono na RUN Master), osim onih navedenih u tablici 14.

**Tablica 14: programiranje na RUN Slave neovisno o motoreduktoru RUN Master**

Funkcije prve razine (funkcije UKLJUČENO – ISKLJUČENO)	Funkcije druge razine (podesivi parametri)
Stanje pripravnosti	Osjetljivost u prepoznavanju prepreka
Pokretanje	Izlaz za I.O.V.
Način Slave	Kontrola momenta motora
	Popis nepravilnosti





Na Slave možete spojiti:

- jedno zasebno trepćuće svjetlo (Flash)
- jedan zaseban indikator otvorenih vrata (I.O.V.)
- jedan zaseban osjetljivi rub (Stop)
- jednu zasebnu upravljačku napravu (KpK) koja naređuje potpuno otvaranje samo krila Slave.
- Ulazi za Open i Close ne koriste se na jedinici Slave.

### 7.3.6) Samostalno učenje drugih uređaja

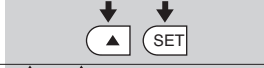
Samostalno učenje uređaja spojenih na BlueBUS i na ulaz za STOP obično se vrši u fazi ugradnje; ako se, međutim, dodaju ili uklone uređaji, samostalno učenje može se ponoviti kao što se vidi u tablici 15.

**Tablica 15: samostalno učenje drugih uređaja**

	Primjer
1. Pritisnite i držite pritisnute tipke [▲] i [Set]	
2. Otpustite tipke kad LED žaruljice L1 i L2 počnu vrlo brzo treptati (nakon oko 3 s)	
3. Pričekajte nekoliko sekundi da kontrolna jedinica završi samostalno učenje uređaja	
4. Na završetku samostalnog učenja LED L1 i L2 prestat će treptati, LED STOP mora ostati upaljen, dok će se LED L1...L8 paliti na temelju statusa funkcija UKLJUČENO-ISKLJUČENO koje predstavljaju.	

**⚠ Nakon dodavanja ili uklanjanja uređaja treba ponovno izvršiti završno ispitivanje automatizacije kako se navodi u odlomku „5.1 Završno ispitivanje“.**

## 7.4) Posebne funkcije

### 7.4.1) Funkcija „Uvijek otvori“

Funkcija „Uvijek otvori“ značajka je kontrolne jedinice koja uvijek omogućava upravljanje jednim manevrom otvaranja kad naredba „Korak po korak“ traje dulje od 2 sekunde; to je korisno na primjer za spajanje na priključni terminal KpK kontakta jednog vremenskog

programatora za držanje otvorenih vrata određeno vrijeme. Ova značajka vrijedi bilo kako da je programiran ulaz za KpK, osim u slučaju programiranja kao što je „Stambena zgrada 2“, vidjeti parametar „Funkcija KpK“ u tablici 9.

### 7.4.2) Funkcija „Ipak pokreni“

U slučaju da neki sigurnosni uređaj ne radi pravilno ili uopće ne radi, dvorišnim vratima ipak se može naređivati i pomicati ih u načinu „Prisutna osoba“.

Detalje vidjeti u odlomku „Upravljanje kad sigurnosni uređaji ne rade“ u prilogu „Upute i upozorenja za korisnika motoreduktorom RUN“.

### 7.4.3) Kontrolni sustav grijanja i hlađenja

RUN raspolaže jednim sofisticiranim sustavom za kontrolu temperature motora. Vrijednost unutarnje temperature motoreduktora RUN detektira jedan specifičan senzor koji služi i za upravljanje sustavom klimatizacije: on je u stanju ugrijati motor kad se vanjska temperatura

spusti ispod praga od oko 0 °C (ako se funkciju „Grijanje“ aktiviralo putem jedinice za daljinsko programiranje „OperaView“) ili ubrzati hlađenje motora kad temperatura premaši oko 40 °C.

### 7.4.4) Obavijest o potrebnom održavanju

RUN omogućava obavještanje korisnika kad treba izvršiti kontrolu radi održavanja automatizacije. Broj manevara nakon kojeg će se to signalizirati možete odabrati među 8 razina, putem podesivog parametra „Obavijest o potrebnom održavanju“ (vidjeti tablicu 9). Razina 1 podešavanja je „automatska“ i vodi računa o težini manevara, tj. o naprežanju i o trajanju manevara, dok su ostala podešavanja određena na temelju broja manevara.

Zahtjevanje održavanja signalizira se putem trepćućeg svjetla Flash ili žaruljicom spojenom na izlaz za I.O.V. kad je ona programirana kao „Indikator održavanja“ (vidjeti tablicu 9).







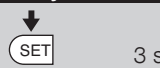

Na temelju broja izvedenih manevara u odnosu na programirano ograničenje, trepćuće svjetlo Flash i indikator održavanja daju signale navedene u tablici 16.

**Tablica 16: obavijest o potrebnom održavanju svjetlom Flash i indikatorom održavanja**

Broj manevara	Signal Flash	Signal indikatora održavanja
Ispod 80% od ograničenja	Normalan (0,5 s upaljeno; 0,5 s ugašeno)	Upaljen 2 s na početku otvaranja
Od 81 do 100% ograničenja	Na početku manevara ostaje upaljeno 2 s, zatim nastavlja normalno	Trepće tijekom cijelog manevara
Preko 100% ograničenja	Na početku i na kraju manevara ostaje upaljeno 2 s, zatim nastavlja normalno	Stalno trepće



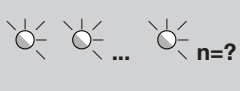



### Provjera broja izvršenih manevara

Broj izvršenih manevara kao postotak postavljenog ograničenja možete provjeriti pomoću funkcije „Obavijest o potrebnom održavanju”. Da biste tu provjeru obavili, postupite kako se navodi u tablici 17.

Tablica 17: provjera broja izvršenih manevara		Primjer
1.	Pritisnite i držite pritisnutu tipku <b>[Set]</b> oko 3 s	
2.	Otpustite tipku <b>[Set]</b> kad LED L1 počne treptati	
3.	Pritisnite tipke <b>[▲]</b> ili <b>[▼]</b> kako bi se treptanje premjestilo na L7, tj. „Ulazni LED” za parametar „Obavijest o potrebnom održavanju”	
4.	Pritisnite i zadržite pritisnutu tipku <b>[Set]</b> ; tipku <b>[Set]</b> treba zadržati pritisnutu za vrijeme vršenja koraka 5, 6 i 7	
5.	Pričekajte oko 3 s, nakon čega će se upaliti LED koji predstavlja trenutnu razinu parametra „Obavijest o potrebnom održavanju”	
6.	Pritisnite i odmah otpustite tipke <b>[▲]</b> i <b>[▼]</b> .	
7.	LED koji odgovara odabranoj razini nekoliko će puta zatreptati. Broj treptaja označava postotak izvršenih manevara (u višekratnicima od 10%) u odnosu na postavljeno ograničenje. Na primjer: ako je obavijest o potrebnom održavanju postavljena na L5 tj. 10.000, 10% je 1000 manevara; ako LED zatreptće 4 puta, znači da se dostiglo 40% manevara (tj. između 4000 i 4999 manevara). Ako se nije dostiglo 10% manevara, neće biti nijednog treptaja.	
8.	Otpustite tipku <b>[Set]</b>	

### Resetiranje brojača manevara

Nakon održavanja sustava morate resetirati brojač manevara. Postupite kako se navodi u tablici 18.

Tablica 18: resetiranje brojača manevara		Primjer
1.	Pritisnite i držite pritisnutu tipku <b>[Set]</b> oko 3 s	
2.	Otpustite tipku <b>[Set]</b> kad LED L1 počne treptati	
3.	Pritisnite tipke <b>[▲]</b> ili <b>[▼]</b> kako bi se treptanje premjestilo na L7, tj. „Ulazni LED” za parametar „Obavijest o potrebnom održavanju”	
4.	Pritisnite i zadržite pritisnutu tipku <b>[Set]</b> ; tipku <b>[Set]</b> treba zadržati pritisnutu za vrijeme vršenja koraka 5 i 6	
5.	Pričekajte oko 3 s, nakon čega će se upaliti LED koji predstavlja trenutnu razinu parametra „Obavijest o potrebnom održavanju”	
6.	Pritisnite i držite pritisnute najmanje 5 sekundi tipke <b>[▲]</b> i <b>[▼]</b> , zatim otpustite 2 tipke. LED koji odgovara odabranoj razini nizom brzih treptaja signalizirat će da se brojač manevara resetirao.	
7.	Otpustite tipku <b>[Set]</b>	

### 7.5) Spajanje drugih uređaja

Ako se ukaže potreba za napajanjem vanjskih uređaja, na primjer čitača kartice za transpondere ili svjetla za osvjetljenje selektora s ključem, napajanje možete iskoristiti kao što se vidi na slici 27. Napon napajanja je 24 VCC -30% ÷ +50% maksimalnom raspoloživom strujom od 100 mA.

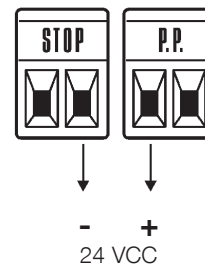

## 7.6) Rješavanje problema

U tablici 19 možete naći korisne naznake koje će vam pomoći u rješavanju eventualnih neispravnosti u radu do kojih može doći tijekom ugradnje ili u slučaju kvara.

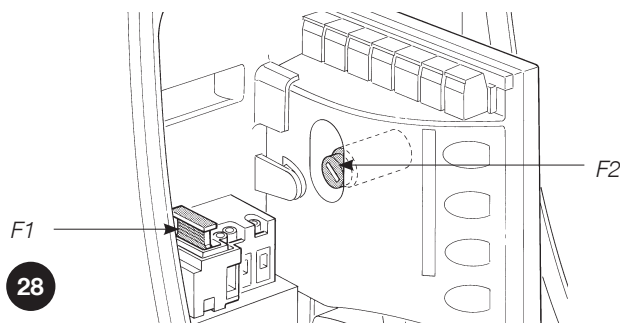







**Tablica 19: pronalaženje kvarova**

Simptomi	Preporučene provjere
Radioodašiljač ne upravlja vratima i ne pali se LED na odašiljaču	Provjerite da baterije odašiljača nisu prazne, eventualno ih zamijenite
Radioodašiljač ne upravlja vratima, ali se LED na odašiljaču pali	Provjerite je li odašiljač pravilno pohranjen u radioprijemniku
Nije moguće narediti nijedan manevar i LED „BlueBUS” ne trepće	Provjerite napaja li se RUN mrežnim naponom. Provjerite da osigurači nisu pregorjeli; ako treba, provjerite uzrok kvara pa ih zamijenite drugima iste jakosti struje i jednakih karakteristika.
Nije moguće narediti nijedan manevar i trepćuće svjetlo je ugašeno	Provjerite da se naredba stvarno prima. Ako naredba stiže na ulaz za KpK, pripadajući LED „KpK” mora se upaliti; ako se, naprotiv, koristi radioodašiljač, LED „BlueBUS” mora odgovoriti s dva brza treptaja.
Nije moguće narediti nijedan manevar i trepćuće svjetlo treptaje nekoliko puta	Pobrojite broj treptaja i provjerite prema onom što se navodi u tablici 21
Manevar počne, ali odmah nakon toga dolazi do promjene smjera	Odabrana osjetljivost u prepoznavanju prepreka možda je previsoka za tip dvorišnih vrata. Provjerite ima li prepreka i eventualno odaberite nižu osjetljivost. Provjerite ima li tijekom izvođenja manevara napona na priključnom terminalu FLASH za trepćuće svjetlo (budući da isprekidano svijetli, vrijednost napona nije važna: oko 10-30 VCC); ako ima napona, uzrok problema je žarulja koju treba zamijeniti novom jednakih karakteristika; ako napona nema, možda je došlo do preopterećenja na izlazu za FLASH, provjerite da na kabelu nije došlo do kratkog spoja. Provjerite tip programirane funkcije za izlaz za I.O.V. (L4 u tablici 9)
Manevar se izvodi kako treba, ali trepćuće svjetlo ne radi	Kad bi indikator trebao biti upaljen, provjerite ima li napona na priključnom terminalu I.O.V. (oko 24 VCC); ako ima napona, uzrok problema je indikator koji treba zamijeniti novim jednakih karakteristika; ako napona nema, možda je došlo do preopterećenja na izlazu za I.O.V., provjerite da na kabelu nije došlo do kratkog spoja.

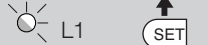
### 7.6.1) Popis povijesti nepravilnosti

RUN omogućava prikazivanje eventualnih nepravilnosti do kojih je došlo u posljednjih 8 manevara, na primjer prekid jednog manevara zbog interveniranja neke fotoćelije ili jednog osjetljivog ruba. Kako biste provjerili popis nepravilnosti postupite kao u tablici 20.

**Tablica 20: povijest nepravilnosti**

	Primjer
1. Pritisnite i držite pritisnutu tipku <b>[Set]</b> oko 3 s	 3 s
2. Otpustite tipku <b>[Set]</b> kad LED L1 počne treptati	
3. Pritisnite tipke <b>[▲]</b> ili <b>[▼]</b> kako bi se treptanje premjestilo na L8, tj. „Ulazni LED” za parametar „Popis nepravilnosti”	
4. Pritisnite i zadržite pritisnutu tipku <b>[Set]</b> ; tipku <b>[Set]</b> treba zadržati pritisnutu za vrijeme vršenja koraka 5 i 6	
5. Pričekajte oko 3 s, nakon čega će se upaliti odgovarajuće LED žaruljice za manevre kod kojih je došlo do nepravilnosti. LED L1 pokazuje rezultat posljednjeg izvršenog manevara, LED L8 pokazuje rezultat osmog. Ako je LED upaljen, znači da je tijekom izvođenja manevara došlo do nepravilnosti; ako je LED ugašen, znači da se manevar završio bez nepravilnosti.	
6. Pritisnite tipke <b>[▲]</b> i <b>[▼]</b> kako biste odabrali željeni manevar: Broj treptaja pripadajuće LED žaruljice bit će jednak broju treptaja kojim obično odgovara trepćuće svjetlo nakon neke nepravilnosti (vidjeti tablicu 21).	
7. Otpustite tipku <b>[Set]</b>	

## 7.7) Dijagnostika i signali

Putem posebnih signala pojedinih uređaja moguće je prepoznati status rada ili eventualno neispravan rad.

### 7.7.1) Signaliziranje treptućim svjetlom

Trepćuće svjetlo FLASH tijekom izvođenja manevra trepće jednim treptajem u sekundi; kad dođe do nepravilnosti ono trepće kraćim treptajima koji se ponavljaju dva puta odvojeni stankom od jedne sekunde.

**Tablica 21: signaliziranje treptućim svjetlom FLASH**

Brzi treptaji	Uzrok	POSTUPAK
1 treptaj stanka od 1 sekunde 1 treptaj	Greška na sustavu BlueBUS	Na početku manevra provjera uređaja spojenih na BlueBUS ne odgovara onima pohranjenim u fazi samostalnog učenja. Jedan ili više uređaja možda su u kvaru, provjerite i zamijenite; ako su izvršene izmjene, treba ponoviti samostalno učenje (7.3.4 Samostalno učenje drugih uređaja).
2 treptaja stanka od 1 sekunde 2 treptaja	Intervenirala je jedna fotočelija	Na početku manevra jedna ili više fotočelija ne daju dozvolu za pokret, provjerite ima li prepreka. Tijekom kretanja to je normalno ako je stvarno prisutna neka prepreka.
3 treptaja stanka od 1 sekunde 3 treptaja	Interveniralo je „Prepoznavanje prepreka”	Dvorišna vrata tijekom kretanja naišla su na veće trenje; provjerite uzrok
4 treptaja stanka od 1 sekunde 4 treptaja	Intervenirao je ulaz za STOP	Na početku manevra ili tijekom kretanja intervenirao je ulaz za STOP; provjerite uzrok
5 treptaja stanka od 1 sekunde 5 treptaja	Greška u unutarnjim parametrima elektroničke kontrolne jedinice	Pričekajte najmanje 30 sekundi pa pokušajte dati neku naredbu; ako stanje ustraje, mogao bi postojati težak kvar i treba zamijeniti tiskanu pločicu za elektroničke sklopove.
6 treptaja stanka od 1 sekunde 6 treptaja	Premašeno je maksimalno ograničenje za broj manevra po satu	Pričekajte nekoliko minuta da se ograničivač manevara vrati ispod maksimalnog ograničenja.
7 treptaja stanka od 1 sekunde 7 treptaja	Greška u unutarnjim električnih krugovima	Odspojite sve krugove napajanja nekoliko sekundi pa pokušajte dati neku naredbu; ako stanje ustraje, mogao bi postojati težak kvar i treba zamijeniti tiskanu pločicu za elektroničke sklopove.
8 treptaja stanka od 1 sekunde 8 treptaja	Već je prisutna jedna naredba koja ne omogućava izvršavanje drugih naredbi	Provjerite vrstu naredbe koja je stalno prisutna; na primjer, moglo bi se raditi o naredbi vremenskog programatora na ulazu za „Otvori”.

### 7.7.2) Signaliziranja na kontrolnoj jedinici

Na kontrolnoj jedinici motoreduktora RUN postoji niz LED žaruljica: svaka od njih može davati posebne signale i pri normalnom radu i u slučaju nepravilnosti.

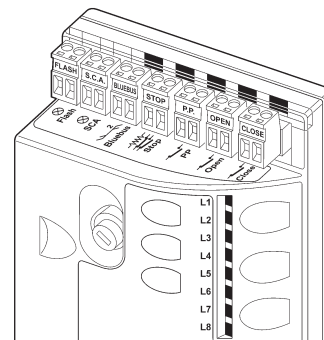

29

**Tablica 22: LED žaruljice na priključnim terminalima kontrolne jedinice**

LED BLUEBUS	Uzrok	POSTUPAK
Ugašen	Nepravilnost	Provjerite ima li napajanja; provjerite da nisu intervenirali osigurači; ako treba, provjerite uzrok kvara pa ih zamijenite drugima jednake jakosti
Upaljen	Teška nepravilnost	Postoji teška nepravilnost; pokušajte nekoliko sekundi isključiti kontrolnu jedinicu; ako stanje ustraje, postoji kvar i treba zamijeniti tiskanu pločicu za elektroničke sklopove
Jedan treptaj u sekundi	Sve je u redu	Normalan rad kontrolne jedinice
2 brza treptaja	Došlo je do promjene u statusu ulaza	To je normalno kad dođe do neke promjene na jednom ulazu: KpK, STOP, OPEN, CLOSE, interveniranje fotočelija ili se rabi radioodašiljač
Niz treptaja odvojenih stankom od jedne sekunde	Razni	Signal je jednak onom za trepćuće svjetlo. Vidjeti tablicu 21
LED STOP	Uzrok	POSTUPAK
Ugašen	Intervenirao je ulaz za STOP	Provjerite uređaje spojene na ulaz za STOP
Upaljen	Sve je u redu	Ulaz za STOP je aktivan
LED KpK	Uzrok	POSTUPAK
Ugašen	Sve je u redu	Ulaz za KpK nije aktivan
Upaljen	Intervenirao je ulaz za KpK	To je normalno ako je uređaj spojen na ulaz za KpK stvarno aktivan
LED OTVORI	Uzrok	POSTUPAK
Ugašen	Sve je u redu	Ulaz za OTVORI nije aktivan
Upaljen	Intervenirao je ulaz za OPEN	To je normalno ako je uređaj spojen na ulaz za OTVORI stvarno aktivan
LED ZATVORI	Uzrok	POSTUPAK
Ugašen	Sve je u redu	Ulaz za ZATVORI nije aktivan
Upaljen	Intervenirao je ulaz za CLOSE	To je normalno ako je uređaj spojen na ulaz za ZATVORI stvarno aktivan

**Tablica 23: LED žaruljice na tipkama kontrolne jedinice**

LED 1	Opis
Ugašen	Tijekom normalnog rada pokazuje da „Automatsko zatvaranje” nije aktivno
Upaljen	Tijekom normalnog rada pokazuje da je „Automatsko zatvaranje” aktivno
Trepće	<ul style="list-style-type: none"> <li>• Programiranje funkcija u tijeku</li> <li>• Ako trepće zajedno s L2, znači da treba izvršiti fazu samostalnog učenja uređaja (vidjeti odlomak „4.3 Samostalno učenje uređaja”).</li> </ul>
LED L2	Opis
Ugašen	Tijekom normalnog rada pokazuje da „Ponovno zatvori nakon fotočelije” nije aktivno.
Upaljen	Tijekom normalnog rada pokazuje da je „Ponovno zatvori nakon fotočelije” aktivno.
Trepće	<ul style="list-style-type: none"> <li>• Programiranje funkcija u tijeku</li> <li>• Ako trepće zajedno s L1, znači da treba izvršiti fazu samostalnog učenja uređaja (vidjeti odlomak „4.3 Samostalno učenje uređaja”).</li> </ul>
LED L3	Opis
Ugašen	Tijekom normalnog rada pokazuje da „Uvijek zatvori” nije aktivno.
Upaljen	Tijekom normalnog rada pokazuje da je „Uvijek zatvori” aktivno.
Trepće	<ul style="list-style-type: none"> <li>• Programiranje funkcija u tijeku</li> <li>• Ako trepće zajedno s L4, znači da treba izvršiti fazu samostalnog učenja dužine krila (vidjeti odlomak „4.4 Samostalno učenje dužine krila”).</li> </ul>
LED L4	Opis
Ugašen	Tijekom normalnog rada pokazuje da „Stanje pripravnosti” nije aktivno.
Upaljen	Tijekom normalnog rada pokazuje da je „Stanje pripravnosti” aktivno.
Trepće	<ul style="list-style-type: none"> <li>• Programiranje funkcija u tijeku</li> <li>• Ako trepće zajedno s L3, znači da treba izvršiti fazu samostalnog učenja dužine krila (vidjeti odlomak „4.4 Samostalno učenje dužine krila”).</li> </ul>
LED L5	Opis
Ugašen	Tijekom normalnog rada pokazuje da „Pokretanje” nije aktivno.
Upaljen	Tijekom normalnog rada pokazuje da je „Pokretanje” aktivno.
Trepće	Programiranje funkcija u tijeku
LED L6	Opis
Ugašen	Tijekom normalnog rada pokazuje da „Prethodno treptanje” nije aktivno.
Upaljen	Tijekom normalnog rada pokazuje da je „Prethodno treptanje” aktivno.
Trepće	Programiranje funkcija u tijeku
LED L7	Opis
Ugašen	Tijekom normalnog rada pokazuje da ulaz za ZATVORI aktivira jedan manevar zatvaranja
Upaljen	Tijekom normalnog rada pokazuje da ulaz za ZATVORI aktivira jedan manevar djelomičnog otvaranja
Trepće	Programiranje funkcija u tijeku
LED L8	Opis
Ugašen	Tijekom normalnog rada pokazuje da je RUN konfiguriran kao Master
Upaljen	Tijekom normalnog rada pokazuje da je RUN konfiguriran kao Slave
Trepće	Programiranje funkcija u tijeku

## 7.8) Dodatna oprema

Za motoreduktor RUN predviđa se sljedeća opcijaska dodatna oprema:

- SMXI ili SMXIS: radioprijemnik 433,92 MHz s digitalnim kodiranjem „Rolling Code”.
- ONEXI: radioprijemnik 433,92 MHz s digitalnim kodiranjem „Rolling Code”; posjeduje Način III za slanje 15 vrsti naredbi kontrolnoj jedinici.

- OperaView: jedinica za daljinsko programiranje. Pogledajte kompletan i ažuriran popis dodatne opreme u katalogu proizvođača Nice S.p.A.

### 7.8.1) Jedinica za daljinsko programiranje

Na specifičan konektor BusT4 (vidjeti sliku 30) možete spojiti jedinicu za daljinsko programiranje Oview koja omogućava potpuno i brzo upravljanje ugradnjom, održavanjem i dijagnostikom eventualnih neispravnosti u radu.

Kako biste mogli pristupiti konektoru morate skinuti membranu kao što se vidi na slici 31. Jedinica za daljinsko programiranje može se nalaziti na udaljenosti od kontrolne jedinice sve do 100 m kabela; može istovremeno biti spojena na više kontrolnih jedinica (do 16), može ostati spojena čak i tijekom normalnog rada motoreduktora RUN; u tom slučaju jedan specifičan „korisnički” izbornik omogućava slanje naredbi kontrolnoj jedinici. Ako je u kontrolnu jedinicu ugrađen radioprijemnik tipa OXI ili OXIT, putem jedinice za daljinsko programiranje može se pristupiti parametrima pohranjenih odašiljača.

Za te je funkcije potreban spojni kabel s 4 vodiča (BusT4). Moguće je i ažurirati firmware kontrolne jedinice motoreduktora RUN.

Daljnje informacije možete pronaći u priručniku s uputama za programator Oview.

**VAŽNO** – Više detalja o svim funkcijama sustava NiceOpera i operativne međuovisnosti koja povezuje razne uređaje sustava pogledajte u općem priručniku „NiceOpera System Book” raspoloživom i na internetskim stranicama [www.niceforyou.com](http://www.niceforyou.com).

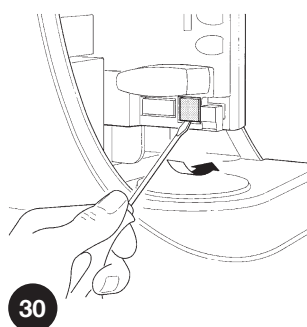

30

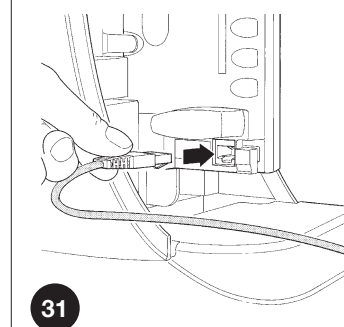

31

## 8) Tehničke karakteristike

U cilju poboljšanja vlastitih proizvoda, Nice S.p.a zadržava pravo izmjene tehničkih karakteristika u bilo kom trenutku i bez prethodne obavijesti, no zadržavajući nepromijenjene funkcije i namjenu.

Sve navedene tehničke karakteristike odnose se na temperaturu okoline 20 °C (±5 °C).

Tehničke karakteristike motoreduktora RUN		
Tip modela	RUN 1800 – RUN 1800P – RUN 1800/V1	RUN 2500 – RUN 2500P
Vrsta	Elektromehanički motoreduktor za automatsko kretanje kliznih vrata za industrijsku primjenu, upotpunjen elektroničkom kontrolnom jedinicom.	
Zupčanik	Broj zuba 18; modul 4*	
Maksimalni moment pokretanja (odgovara sposobnosti razvijanja sile za stavljanje krila u pokret)	40 Nm (1110 N)	50 Nm (1390 N)
Nazivni moment (odgovara sposobnosti razvijanja sile za održavanje krila u pokretu)	20 Nm (560 N)	30 Nm (830 N)
Brzina (bez opterećenja)	10 m/min (12 m/min verzija /V1)	
Brzina (pri nazivnom momentu)	8,5 m/min (8,9 m/min verzija /V1)	
Maksimalna učestalost radnih ciklusa (pri nazivnom momentu)	11 ciklusa/sat (264 ciklusa/dan), za vrata od 15 m (što je jednako ciklusu od 63%); (kontrolna jedinica ograničava cikluse na maksimalna ograničenja navedena u tablicama 2 i 3)**	15 ciklusa/sat (365 ciklusa/dan), za vrata od 15 m (što je jednako ciklusu od 88%); (kontrolna jedinica ograničava cikluse na maksimalna ograničenja navedena u tablicama 2 i 3)**
Maksimalno vrijeme neprekidnog rada (pri nazivnom momentu)	40 minuta (kontrolna jedinica ograničava neprekidan rad na maksimalna ograničenja navedena u tablicama 2 i 3)***	60 minuta (kontrolna jedinica ograničava neprekidan rad na maksimalna ograničenja navedena u tablicama 2 i 3)***
Radna ograničenja	Općenito, RUN je projektiran za automatizaciju dvorišnih vrata prema ograničenjima težine ili dužine navedenim u tablicama 2, 3 i 4	
Trajnost	Procijenjena između 150.000 i 450.000 ciklusa, prema uvjetima navedenim u tablici 4	
Napajanje motoreduktora RUN 1800 – 2500	230 VAC (+10% -15%) 50 Hz	
Napajanje motoreduktora RUN 1800/V1-2500/V1	120 VAC (+10% -15%) 60 Hz	
Maksimalna struja pokretanja [izražena u A]	700 W [3 A] [5 A verzija/V1]	870 W [3,8 A]
Snaga pri nazivnom momentu [izražena u A]	400 W [1,8 A] [3 A verzija/V1]	600 W [2,7 A]
Klasa izolacije	1 (potrebno je zaštitno uzemljenje)	
Izlaz za trepćuće svjetlo	za 2 trepćuća svjetla LUCYB (žarulja 12 V, 21 W)	
Izlaz za I.O.V.	za 1 žarulju 24 V maksimalno 4 W (izlazni napon može se kretati između -30 i +50% te može upravljati čak i malim relejima)	
Izlaz za BLUEBUS	jedan izlaz s maksimalnim opterećenjem od 15 jedinica BlueBus	
Ulaz za STOP	Za normalno zatvorene, normalno otvorene kontakte ili one sa stalnim otpornikom 8,2 kΩ; u samostalnom učenju (promjena u odnosu na pohranjenu vrijednost izaziva naredbu „STOP“)	
Ulaz za KpK	za normalno otvorene kontakte (zatvaranje kontakta izaziva naredbu KpK)	
Ulaz za OTVORI	za normalno otvorene kontakte (zatvaranje kontakta izaziva naredbu OTVORI)	
Ulaz za ZATVORI	za normalno otvorene kontakte (zatvaranje kontakta izaziva naredbu ZATVORI)	
Konektor za radio	Konektor SM za prijemnike SMXI, SMXIS ili ONEXI	
Ulaz za RADIOANTENU	Ulaz za RADIOANTENU 52 Ω za kabel tipa RG58 ili sličan	
Programabilne funkcije	8 funkcija tipa UKLJUČENO-ISKLJUČENO i 8 podesivih funkcija (vidjeti tablice 7 i 9)	
Funkcije u samostalnom učenju	Samostalno učenje uređaja spojenih na izlaz za BlueBus Samostalno učenje tipa uređaja za „STOP“ (NO, NZ kontakt ili otpornik 8,2 kΩ) Samostalno učenje dužine vrata i izračunavanje točaka usporavanja i djelomičnog otvaranja.	
Radna temperatura	-20 °C ÷ 50 °C	
Uporaba u prilično kiseloj, slanoj ili potencijalno eksplozivnoj atmosferi	Ne	
Stupanj zaštite	IP 44	
Dimenzije i težina	400 x 255 (V) 390; 24,5 kg	

\* Raspoloživ je opcijski zupčanik s 12 zuba, modul 6.

\*\* Na 50 °C i s vratima od 15 metara maksimalna radna učestalost iznosi 7 ciklusa/sat (što je jednako ciklusu od 40%).

\*\*\* Na 50 °C maksimalno neprekidno radno vrijeme iznosi 10 minuta.



- **Prije uporabe automatizacije prvi put** neka vam ugraditelj objasni izvore preostalih rizika te posvetite nekoliko minuta čitanju priručnika **s uputama i upozorenjima za korisnika** koji vam je isporučio ugraditelj. Čuvajte priručnik za svaku buduću potrebu i isporučite ga eventualnom novom vlasniku sustava automatizacije.
- **Vaš sustav automatizacije stroj je koji vjerno izvodi vaše naredbe;** u slučaju nerazborite i neodgovarajuće uporabe on može postati opasan: nemojte naređivati kretanje automatizacije ako se u njenom djelokrugu nalaze osobe, životinje ili stvari.
- **Djeca:** sustav automatizacije jamči visoki stupanj sigurnosti sprječavajući, svojim uređajima za prepoznavanje, kretanje u prisutnosti osoba ili stvari te jamčeći uvijek predvidljivo i sigurno aktiviranje. Opreznosti radi, djeci ipak treba zabraniti igranje u blizini automatizacije i – kako bi se izbjegla nenamjerna aktiviranja – daljinske upravljače ne smije se ostavljati na njihovom dohvat: **to nije igračka!**
- **Nepravilnosti:** čim primijetite bilo kakvo nepravilno ponašanje automatizacije, isključite električno napajanje sustava i izvedite ručno deblokiranje. Ne pokušavajte sami vršiti nikakve popravke nego zatražite intervenciju ugraditelja: sustav u međuvremenu, nakon što ste deblokirali motoreduktor kao što se opisuje u nastavku, može raditi kao neautomatizirano otvaranje.
- **Održavanje:** kao svaki stroj, vaš sustav automatizacije treba periodično održavati kako bi radio što je moguće dulje i u potpunoj sigurnosti. Dogovorite s ugraditeljem plan održavanja po periodičnoj učestalosti; tvrtka Nice preporučuje obavljanje održavanja svakih 6 mjeseci kod normalne kućne uporabe, no to se razdoblje može mijenjati ovisno o intenzitetu uporabe. Samo kvalificirano osoblje smije vršiti zahvate kontrole, održavanja ili popravka.
- Čak iako smatrate da se u to razumijete, nemojte vršiti izmjene na sustavu, parametrima programiranja ni podešavanje automatizacije: za to je odgovoran ugraditelj.
- Završno ispitivanje, periodična održavanja i eventualne popravke mora dokumentirati onaj tko ih obavlja, a dokumente treba čuvati vlasnik sustava.

**Jedini zahvati** koje smijete i koje vam preporučujemo da periodično izvršite su čišćenje stakalaca na fotočelijama i uklanjanje eventualnog lišća ili kamenja koji bi mogli ometati automatizaciju. Kako biste spriječili da netko pokrene dvorišna vrata, ne zaboravite prvo **deblokirati automatizaciju** (kao što se opisuje u nastavku) i za čišćenje se služite jedino krpom koju ste malo navlažili vodom.

**Deblokiranje i ručno pomicanje:** prije obavljanja ove radnje obratite **pažnju** na to da se deblokiranje može obaviti samo ako je krilo zaustavljeno.

**1** Kliznite disk koji pokriva bravu.

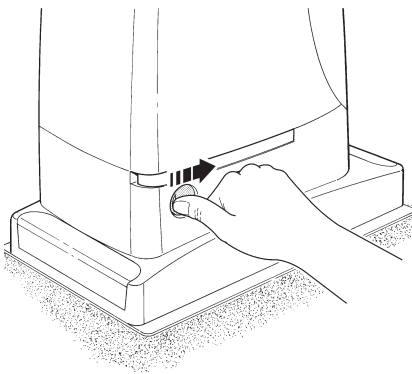

**2** Uvucite ključ i okrenite ga u smjeru kazaljke na satu.

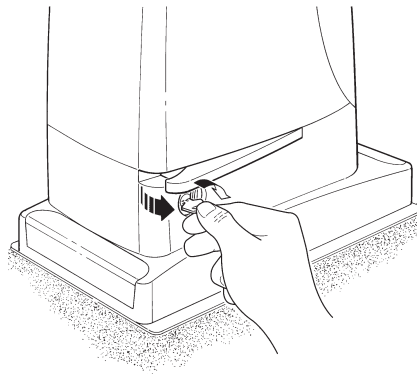

**3** Povucite ručku za deblokiranje.

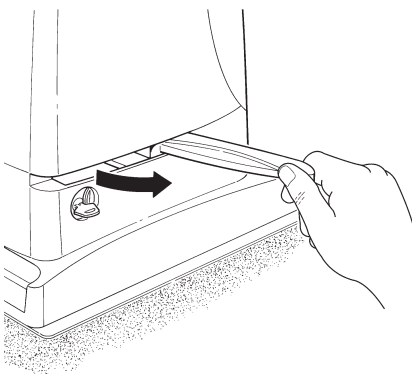

**4** Ručno pomaknite krilo.

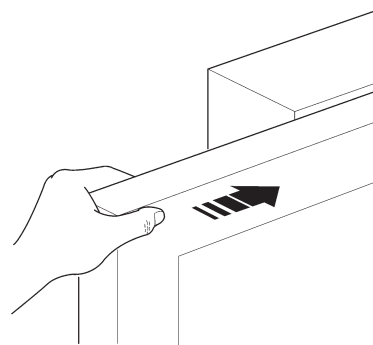

**Za blokiranje:** izvršite iste radnje obrnutim redoslijedom

**Upravljanje kad sigurnosni uređaji ne rade:** u slučaju da sigurnosni uređaji na dvorišnim vratima ne rade pravilno, vratima se ipak može naređivati.

- Aktivirajte naredbu za dvorišna vrata (daljinskim upravljačem, selektorom s ključem itd.); ako je sve u redu, vrata će se normalno otvoriti ili zatvoriti, u suprotnom će trepćuće svjetlo nekoliko puta zatreptati i manevar neće početi (broj treptaja ovisi o razlogu zbog kojeg manevar ne može početi).
- U tom slučaju morate, u roku od tri sekunde, ponovno **aktivirati i držati aktiviranu** naredbu.
- Nakon oko 2 s dvorišna vrata počinju se kretati u načinu „Prisutna osoba”, tj. dok naredbu držite aktivnu, vrata se nastavljaju kretati; čim naredbu deaktivirate, vrata se zaustavljaju.

**⚠ Kad sigurnosni uređaji ne rade, automatizaciju treba što prije popraviti.**

**Zamjena baterije daljinskog upravljača:** ako nakon određenog vremena izgleda da se naređivanje radiosignalima pogoršalo ili uopće ne funkcionira, možda se jednostavno ispraznila baterija (ovisno o uporabi može proći od nekoliko mjeseci do više od jedne godine). To ćete primijetiti po tome što se indikator potvrde prijensa ne pali, svijetli slabim svjetlom ili se samo na trenutak upali. Prije nego što se obratite ugraditelju pokušajte zamijeniti bateriju onom iz nekog drugog odašiljača koji eventualno radi: ako je ona uzrok nepravilnosti, bit će dovoljno zamijeniti bateriju drugom istog tipa.

Baterije sadrže onečišćujuće tvari: nemojte ih bacati u običan otpad nego postupite kako se to predviđa lokalnim propisima.

## EZ izjava o sukladnosti i izjava o ugradnji „djelomično dovršenog stroja”

Izjava u skladu s direktivama: 2004/108/EZ (EMC); 2006/42/EZ (o strojevima) Prilog II, odjeljak B

**Napomena** – Sadržaj ove izjave odgovara onom što se izjavljuje u službenom dokumentu pohranjenom u sjedištu tvrtke Nice S.p.A., a posebno njegovoj posljednjoj raspoloživoj reviziji prije tiskanja ovog priručnika. Tekst koji se ovdje nalazi prilagođen je u uredničke svrhe. Kopiju originalne izjave možete zatražiti od tvrtke Nice S.p.A. (TV) Italy.

**Broj:** 238/RUN

**Revizija:** 5

**Jezik:** HR

**Naziv proizvođača:**

Nice S.p.A.

**Adresa:**

Via Pezza Alta N°13, 31046 Rustignè di Oderzo (TV) Italy

**Osoba ovlaštena za sastavljanje**

**tehničke dokumentacije:**

Nice S.p.A.

**Vrsta proizvoda:**

Elektromehanički motoreduktor s ugrađenom kontrolnom jedinicom

**Model:**

RUN1800, RUN2500, RUN1800P, RUN2500P

**Dotatna oprema:**

Radioprijemnici mod. SMXI, SMXIS i ONEXI

Niže potpisani Mauro Sordini, u svojstvu glavnog izvršnog direktora, pod vlastitom odgovornošću izjavljuje da je navedeni proizvod u skladu s odredbama sljedećih direktiva:

- DIREKTIVA 2004/108/EZ EUROPSKOG PARLAMENTA I VIJEĆA od 15. prosinca 2004. o usklađivanju zakonodavstava država članica o elektromagnetskoj kompatibilnosti i stavljanju izvan snage Direktive 89/336/EEZ, prema sljedećim usklađenim normama: EN 61000-6-2:2005, EN 61000-6-3:2007+A1:2011

S obzirom na zahtjeve predviđene za „djelomično dovršene strojeve”, proizvod je u skladu i sa sljedećom Direktivom:

Direktiva 2006/42/EZ EUROPSKOG PARLAMENTA I VIJEĆA od 17. svibnja 2006. o strojevima, kojom se mijenja Direktiva 95/16/EZ (preinaka)

- Izjavljuje se da je pripadajuća tehnička dokumentacija sastavljena u skladu s Prilogom VII B Direktive 2006/42/EZ te da su se poštovali sljedeći bitni zahtjevi: 1.1 – 1.1.2 – 1.1.3 – 1.2.1 – 1.2.6 – 1.5.1 – 1.5.2 – 1.5.5 – 1.5.6 – 1.5.7 – 1.5.8 – 1.5.10 – 1.5.11
- Proizvođač se obvezuje dostaviti mjerodavnim nacionalnim tijelima, na njihov opravdani zahtjev, informacije o „djelomično dovršenom stroju” ne dovodeći u pitanje vlastita prava intelektualnog vlasništva.
- Ako se „djelomično dovršen stroj” pusti u rad u nekoj europskoj državi sa službenim jezikom drukčijim od onog u ovoj izjavi, uvoznik je obavezan ovoj izjavi priložiti njezin prijevod.
- Upozoravamo na to da se „djelomično dovršen stroj” ne smije pustiti u rad sve dok se za konačni stroj u koji se on ugrađuje ne izjavi – prema potrebi – da je sukladan odredbama Direktive 2006/42/EZ.

Proizvod je, osim toga, u skladu sa sljedećim normama:

EN 60335-1:2012 EN 60335-2-103:2003+A11:2009

Proizvod je u skladu sa sljedećim normama ograničeno na njihove primjenjive dijelove:

EN 13241-1:2003+A1:2011, EN 12445:2002, EN 12453:2002, EN 12978:2003+A1:2009

Oderzo, 1. srpnja 2014.

**Inž. Mauro Sordini**  
(Glavni izvršni direktor)



<b>Table of contents:</b>		<b>page</b>		
<b>1</b>	Warnings	29	<b>7.2.1</b>	Level one functions (ON-OFF functions) 39
<b>2</b>	Product description and applications	30	<b>7.2.2</b>	Level one programming (ON-OFF functions) 40
<b>2.1</b>	Operating limits	30	<b>7.2.3</b>	Level two functions (adjustable parameters) 40
<b>2.2</b>	Typical system	32	<b>7.2.4</b>	Level two programming (adjustable parameters) 41
<b>2.3</b>	List of cables	32	<b>7.2.5</b>	Level one programming example (ON-OFF functions) 42
<b>3</b>	Installation	33	<b>7.2.6</b>	Level two programming example (adjustable parameters) 42
<b>3.1</b>	Preliminary checks	33	<b>7.3</b>	Adding or removing devices 42
<b>3.2</b>	Installation of the gearmotor	33	<b>7.3.1</b>	BlueBUS 42
<b>3.3</b>	Fixing of the limit switch bracket on versions with inductive limit switch	34	<b>7.3.2</b>	STOP input 43
<b>3.4</b>	Installation of the various devices	35	<b>7.3.3</b>	Photocells 43
<b>3.5</b>	Electrical connections	35	<b>7.3.4</b>	FT210B Photo-sensor 43
<b>3.6</b>	Description of the electrical connections	36	<b>7.3.5</b>	RUN in "Slave" mode 44
<b>4</b>	Final checks and start up	36	<b>7.3.6</b>	Self-learning Other Devices 45
<b>4.1</b>	Choosing the direction	36	<b>7.4</b>	Special functions 45
<b>4.2</b>	Power supply connection	36	<b>7.4.1</b>	"Always open" Function 45
<b>4.3</b>	Device self-learning	36	<b>7.4.2</b>	"Move anyway" function 45
<b>4.4</b>	Leaf length self-learning	37	<b>7.4.3</b>	Heating and cooling control system 45
<b>4.5</b>	Checking gate movements	37	<b>7.4.4</b>	Maintenance warning 45
<b>4.6</b>	Preset functions	37	<b>7.5</b>	Connection of Other Devices 46
<b>4.7</b>	Radio receiver	37	<b>7.6</b>	Troubleshooting 47
<b>5</b>	Testing and commissioning	37	<b>7.6.1</b>	Malfunctions archive 47
<b>5.1</b>	Testing	38	<b>7.7</b>	Diagnostics and signals 47
<b>5.2</b>	Commissioning	38	<b>7.7.1</b>	Flashing light signalling 48
<b>6</b>	Maintenance and Disposal	38	<b>7.7.2</b>	Signals on the control unit 48
<b>6.1</b>	Maintenance	38	<b>7.8</b>	Accessories 49
<b>6.2</b>	Disposal	38	<b>7.8.1</b>	Remote programming unit 49
<b>7</b>	Additional information	39	<b>8</b>	Technical characteristics 50
<b>7.1</b>	Programming keys	39		Instructions and Warnings for users of RUN gearmotor 51
<b>7.2</b>	Programming	39		CE Declaration of Conformity 53

## 1) Warnings

This manual contains important information regarding safety. Before starting installation of the components, it is important that you read all the information contained herein. Store this manual safely for future use. Due to the dangers which may arise during both the installation and use of the RUN, installation must be carried out in full observance of the laws, provisions and rules currently in force to ensure maximum safety. This chapter provides details of general warnings. Other more specific warnings are detailed in Chapters “3.1 Preliminary Checks” and “5 Testing and Commissioning”.

**⚠ According to the most recent European legislation, the automation of doors or gates is governed by the provisions listed in Directive 98/37/CE (Machine Directive) and, more specifically the standards: EN 13241-1 (harmonised standard); EN 12445; EN 12453 and EN 12635, which enables the declaration of machine conformity to the machine directive.**

Visit “www.niceforyou.com” for further information and guidelines for risk analysis and how to draw up the Technical Documentation. This manual has been especially written for use by qualified fitters. Except for the enclosed specification “Instructions and Warnings for Users of the RUN gearmotor” to be removed by the installer, none of the information provided in this manual can be considered as being of interest to the end users!

- Any use or operation of RUN not explicitly provided for in these instructions is not permitted. Improper use may cause damage and personal injury.
- A risk analysis must be carried out before starting installation, including a the list of essential safety requisites provided for in Enclosure I of the Machine Directive, indicating the relative solutions employed. N.B. Risk analysis is one of the documents included in the “Technical Documentation” for this automation.
- Check whether additional devices are needed to complete the automation with RUN based on the specific application requirements and dangers present. The following risks must be considered: impact, crushing, shearing, dragging, etc. as well as other general dangers.
- Do not modify any components unless such action is specified in this manual. Operations of this type are likely to lead to malfunctions. NICE disclaims any liability for damage resulting from modified products.
- During installation and use, ensure that solid objects or liquids do not penetrate the control unit or other open devices. If necessary, contact the NICE customer service department; use of RUN in these conditions can be dangerous.
- The automation system must not be used until it has been commissioned as described in chapter 5 “Testing and commissioning”.
- The RUN packaging materials must be disposed of in compliance with local regulations.
- If a fault occurs that cannot be solved using the information provided in this manual, contact the NICE customer service department.
- In the event that any automatic switches are tripped or fuses blown, attempt to identify and eliminate the relative fault.
- Disconnect all the power supply circuits before accessing the terminals inside the RUN cover. If the disconnection device is not identifiable, affix the following sign: “WARNING: MAINTENANCE WORK IN PROGRESS”.

Special warnings concerning the suitable use of this product in relation to the 98/37CE “Machine Directive” (ex 89/392/CEE):

- This product is issued on the market as a “machine component” and is therefore manufactured to be integrated in a machine or assembled with other machines in order to create “a machine”, in accordance with the directive 98/37/EC, exclusively in combination with other components and in the manner described in the present instructions manual. As specified in the directive 98/37CE the use of this product is not admitted until the manufacturer of the machine on which this product is mounted has identified and declared it as conforming to the directive 98/37/CE.

Special warnings concerning suitable use of this product in relation to the 73/23/EEC “Low Voltage” Directive and subsequent amendments 93/68/CEE:

- This product complies with the provisions envisaged by the “Low Voltage” Directive if used in the configurations foreseen in this instruction manual and in combination with the articles present in the Nice S.p.a. product catalogue. If the product is not used in the specified configurations or is used with other products that have not been foreseen, the requirements may not be guaranteed; use of the product is prohibited in these conditions until compliance with the requirements foreseen by the directive has been verified by installers.

Special warnings concerning suitable use of this product in relation to the 89/336/EEC “Electromagnetic Compatibility” Directive and subsequent amendments 92/31/EEC and 93/68/EEC:

- This product has undergone tests regarding electromagnetic compatibility in the most critical of use conditions, in the configurations foreseen in this instruction manual and in combination with articles present in the Nice S.p.A. product catalogue. Electromagnetic compatibility may not be guaranteed if used in configurations or with other products that have not been foreseen; use of the product is prohibited in these conditions until compliance with the requirements foreseen by the directive has been verified by installers.

## 2) Product description and applications

RUN is a range of irreversible electromechanical gearmotors used for the automation of sliding gates. They are equipped with an electronic control unit and an "SM" type connector for radio control receivers (optional). Electrical connections to external devices are facilitated thanks to the use of the "BlueBUS" system, which enables the connection of several devices by means of just 2 wires. The list of devices compatible for connection to the Run BlueBUS is given in chapter 7.3.1 "BlueBUS"; an updated list, with relative compatibility

is also available at: [www.niceforyou.com](http://www.niceforyou.com). RUN is equipped with a connector for remote programming units to enable complete and quick management of installation, maintenance, troubleshooting of any malfunctions; refer also to 7.8.1 "Remote programming unit". RUN is electrically powered, in the event of a power failure, the device can be released by means of the special key, to enable manual movement of the gate.

Other products are also part of the RUN range, the difference of which is described in table 1.

Table 1: comparison of the RUN gearmotor main characteristics				
Gearmotor type	RUN1800	RUN1800P	RUN2500	RUN2500P
Limit switch type	electromechanical	inductive proximity	electromechanical	inductive proximity
Maximum leaf length	15m		18m	
Maximum leaf weight	1800 kg		2500 kg	
Peak thrust (corresponding to a force)	40Nm (1110N)		50Nm (1390N)	
Motor	Single phase asynchronous maximum 700W		Single phase asynchronous maximum 870W	

Note: 1kg = 9,81N for example: 1390N = 142 kg

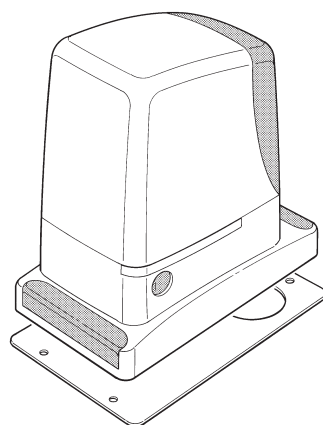

1

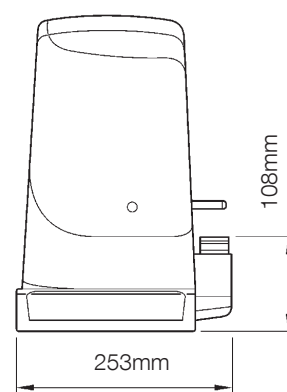
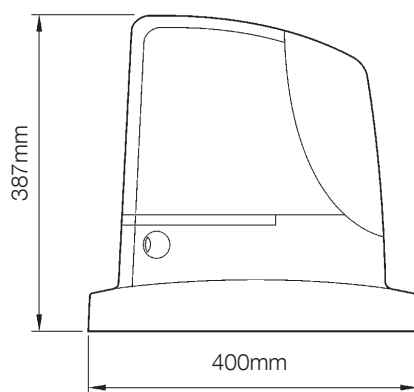

### 2.1) Operating limits

Chapter 8 "Technical Characteristics" provides the only data needed to determine whether the products of the RUN line are suitable for the intended application. The structural characteristics of RUN make it suitable for use on sliding leaves in conformity with the limits specified in tables 2, 3 and 4.

The effective suitability of RUN to automate a sliding gate depends on friction and other factors, even occasional, such as the presence of ice which could obstruct leaf movement. To ensure suitability, it is absolutely vital to measure the force necessary to move the leaf throughout its entire run and ensure that this is less than half of the "nominal torque" indicated in chapter 8 "Technical characteristics" (a 50% margin on the force is recommended, as unfavourable climatic conditions may cause an increase in the friction); furthermore, the

data specified in tables 2 and 3 should be taken into account to establish the number of cycles/hour and consecutive cycles.

Table 2: limits in relation to the length of the leaf				
Leaf width(m)	RUN1800/ RUN1800P		RUN2500/ RUN2500P	
	max. cycles/hour	max. consecutive cycles	max. cycles/hour	max. consecutive cycles
Up to 6	42	28	42	42
6 ÷ 9	28	18	28	28
9 ÷ 12	21	14	21	21
12 ÷ 15	17	11	17	17
15 ÷ 18			14	14

**Table 3: limits in relation to the weight of the leaf**

Leaf weight (kg)	RUN1800/ RUN1800P	RUN2500/ RUN2500P
	Cycle percentage	Cycle percentage
Up to 500	100%	100%
500 ÷ 900	80	80
900 ÷ 1200	75	75
1200 ÷ 1500	60	60
1500 ÷ 1800	50	50
2000 ÷ 2300	---	40
2300 ÷ 2500	---	30

The length of the leaf enables the calculation of both the maximum number of cycles per hour and consecutive cycles, while the weight enables the calculation of the percentage of cycle reduction and the maximum speed allowed. For example, for RUN1800 if the leaf is 10 m long it will be possible to have 21 cycles/hour and 14 consecutive cycles. However, if the leaf weighs 1300 kg, they must be reduced by 60 %, resulting in 9 cycles/hour and 8 consecutive cycles. The control unit has a limiting device which prevents the risk of overheating based on the load of the motor and duration of the cycles. This device triggers when the maximum limit is exceeded. The manoeuvre limiting device also measures the ambient temperature reducing the number of manoeuvres further when the temperature is particularly high.

The “durability” estimate is shown in chapter 8 “Technical characteristics”, which is the average useful life of the product. The value is strongly influenced by the severity index of the manoeuvre, this being the sum of all factors that contribute to wear. To make this estimate, all severity indexes in table 4 must be added together, and the result should be used to check estimated durability in the graph.

For example: for RUN1800 on a gate weighing 1300 kg and 10 m in length, equipped with photocells and other stress related elements obtains a severity index equal to 45% (20+15+10). From the graph the estimated durability is equal to 200.000 cycles.

Note that the estimated durability is calculated on the basis of design specifications and the results of tests performed on prototypes; as this is an estimate only, it does not represent any form of guarantee on the effective durability of the product.

**Table 4: durability estimate in relation to the manoeuvre severity index**

Severity index %	Run		Durability in cycles
	1800	2500	
<b>Leaf weight kg</b>			
Up to 500	5	5	
500 ÷ 900	10	10	
900 ÷ 1200	20	20	
1200 ÷ 1500	30	30	
1500 ÷ 1800	40	40	
1800 ÷ 2200	-	50	
2200 ÷ 2500	-	60	
<b>Leaf length m</b>			
Up to 6	5	5	
6 ÷ 9	10	10	
9 ÷ 12	15	15	
12 ÷ 15	25	25	
15 ÷ 18	-	35	
<b>Other stress related elements</b> (to be taken into consideration if the probability is greater than 10% )			
Ambient temperature greater than 40°C or lower than 0°C or humidity greater than 80%	10	10	
Presence of dust and sand	15	15	
Presence of salinity	20	20	
Photo manoeuvre interruption	10	10	
Stop manoeuvre interruption	20	20	
Thrust active	10	10	
<b>Severity index total%:</b>			

Note: if the index of severity exceeds 100% this means that the conditions are outside the limits of acceptability; in this case the use of a larger-sized model is recommended.

## 2.2) Typical system

Figure 2 shows a typical system for automating a sliding gate using RUN.

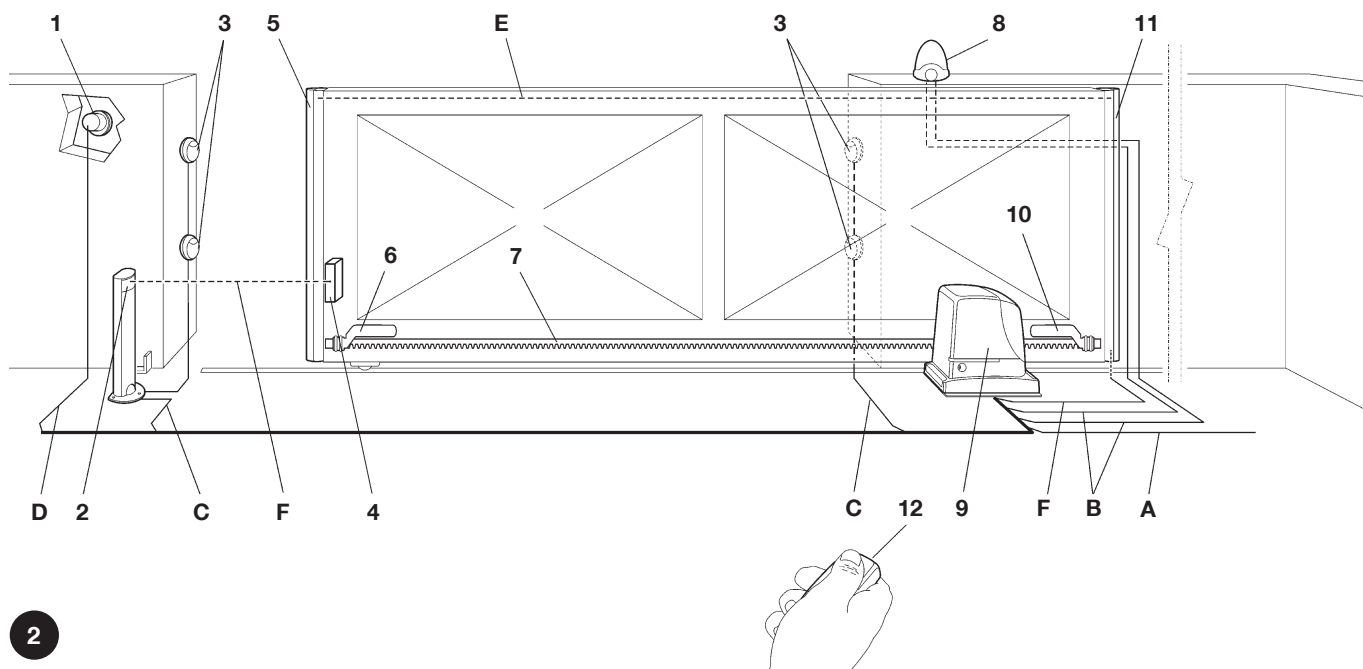

- 1 Key-operated selector switch
- 2 Receiver FT210B
- 3 Photocells
- 4 Transmitter FT210B
- 5 Primary movable edge
- 6 "Open" limit switch bracket
- 7 Rack
- 8 Flashing light with incorporated aerial
- 9 RUN
- 10 "Closed" limit switch bracket
- 11 Primary movable edge (optional)
- 12 Radio transmitter

## 2.3) List of cables

The typical system shown in figure 2 also states the cables required for connection of the various devices, the specifications of which are provided in table 5.

**⚠ The cables used must be suitable for the type of installation; for example, an H03VV-F type cable is recommended for indoor applications, while H07RN-F is suitable for outdoor applications.**

**Table 5: List of cables**

Connection	Cable type	Maximum admissible length
<b>A:</b> Electrical power line	N°1 cable 3x1,5mm <sup>2</sup>	30m (note 1)
<b>B:</b> Flashing light with aerial	N°1 cable 2x0,5mm <sup>2</sup>	20m
	N°1 shielded cable type RG58	20m (less than 5m recommended )
<b>C:</b> Photocells	N°1 cable 2x0,5mm <sup>2</sup>	30m (note 2)
<b>D:</b> Key-operated selector switch	N°2 cable 2x0,5mm <sup>2</sup> (note 3)	50m
<b>E:</b> Connection between 2 movable edges	N°1 cable 2x0,5mm <sup>2</sup> (note 4)	20m
<b>F:</b> Movable edge connection	N°1 cable 2x0,5mm <sup>2</sup> (note 5)	30m

**Note 1:** power supply cable longer than 30 m may be used provided it has a larger gauge, e.g. 3x2,5mm<sup>2</sup>, and that a safety earthing system is provided near the automation unit.

**Note 2:** If the "BLUEBUS" cable is longer than 30 m, up to 50 m, a 2x1mm<sup>2</sup> cable is needed.

**Note 3:** A single 4x0,5mm<sup>2</sup> cable can be used instead of two 2x0,5mm<sup>2</sup> cables.

**Note 4:** Refer to Chapter "7.3.2 STOP Input" in situations where there is more than one edge, for information about the type of connection recommended by the manufacturer.

**Note 5:** special devices which enable connection even when the leaf is moving must be used to connect movable edges to sliding leaves; con l'anta in movimento; nella figura è indicato l'utilizzo di FT210B.



### 3) Installation

**⚠ The installation of RUN must be carried out by qualified personnel in compliance with current legislation, standards and regulations, and the directions provided in this manual.**

#### 3.1) Preliminary checks

Before proceeding with the installation of RUN:

- Check that all the materials are in excellent condition, suitable for use and compliant with current standards.
  - Ensure that the structure of the gate is suitable for automation.
  - Ensure that the weight and dimensions of the leaf fall within the specified operating limits provided in chapter "2.1 Operating limits".
  - Check that the force required to start the movement of the leaf is less than half the "maximum torque", and that the force required to keep the leaf in movement is less than half the "nominal torque". Compare the resulting values with those specified in Chapter "8 Technical Characteristics". The manufacturers recommend a 50% margin on the force, as unfavourable climatic conditions may cause an increase in the friction.
  - Ensure that there are no points of greater friction in the opening or closing travel of the gate leaves.
  - Ensure there is no danger of the gate derailing.
  - Ensure that the mechanical stops are sufficiently sturdy and that there is no risk of deformation even when the leaf hits the mechanical stop violently.
  - Ensure that the gate is well balanced: it must not move by itself when it is placed in any position.
  - Ensure that the area where the gearmotor is fixed is not subject to flooding. If necessary, mount the gearmotor raised from the ground.
  - Ensure that the installation area enables the release of the gearmotor and that it is safe and easy to release it.
- Ensure that the mounting positions of the various devices are protected from impact and that the mounting surfaces are sufficiently sturdy.
  - Components must never be immersed in water or other liquids.
  - Keep RUN away from heat sources and open flames; in acid, saline or potentially explosive atmosphere; this could damage RUN and cause malfunctions or hazardous situations.
  - If there is an access door in the leaf, or within the range of movement of the gate, make sure that it does not obstruct normal travel. Mount a suitable interlock system if necessary.
  - Only connect the control unit to a power supply line equipped with a safety grounding system.
  - The power supply line must be protected by suitable magneto-thermal and differential switches.
  - A disconnection device must be inserted in the power supply line from the electrical mains (the distance between the contacts must be at least 3.5 mm with an overvoltage category of III) or equivalent system, for example an outlet and relative plug. If the disconnection device for the power supply is not mounted near the automation, it must have a locking system to prevent unintentional, unauthorised connection.

#### 3.2) Installation of the gearmotor

The gearmotor must be secured directly to an already existing mounting surface using suitable means, for example expansion bolts. Otherwise, in order to fasten the gearmotor the installer must:

1. Dig a foundation hole with suitable dimensions referring to Figure 3.
2. Prepare one or more conduits for the electrical cables as shown in figure 4.
3. Assemble the 4 clamps on the foundation plate setting one nut underneath and one on top of the plate. The nut underneath the plate must be tightened as shown in Figure 5 so that the threaded part protrudes above the plate by max. 40 mm.
4. Pour the concrete and, before it starts to harden, set the foundation plate to the values shown in Figure 3. Check that it is parallel to the leaf and perfectly level (Figure 6). Wait for the concrete to harden completely.
5. Remove the 4 upper nuts on the plate and then position the gearmotor. Check that it is perfectly parallel to the leaf, then refit and tighten the four nuts and washers supplied, as shown in Figure 7.

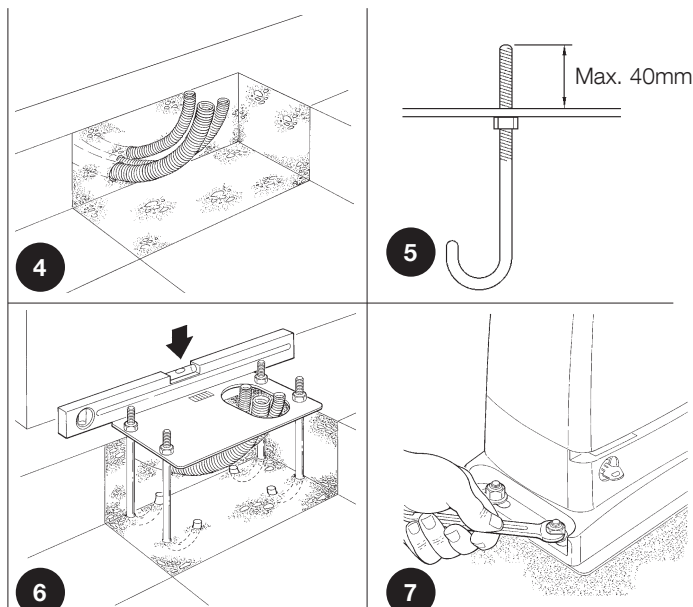
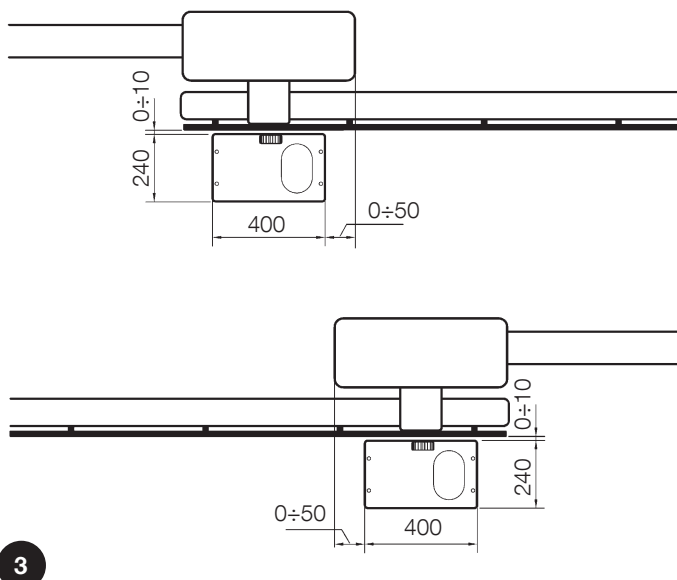

6. Release the gearmotor as shown in “Release and manual movement” paragraph in the Chapter “Instructions and Warnings for users of the RUN gearmotor”.
7. Open the leaf up completely and place the first piece of the rack on the pinion. Check that the beginning of the rack corresponds to the beginning of the leaf, as shown in Figure 8. Leave 1÷2 mm play between the rack and the pinion, then fasten the rack to the leaf using suitable means.

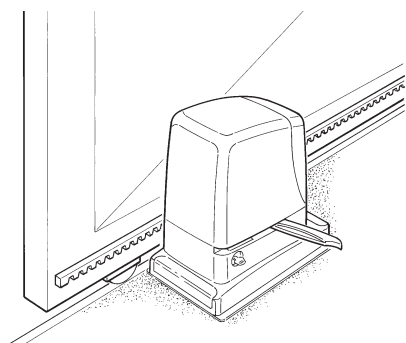

8

**⚠ In order to prevent the weight of the leaf from affecting the gearmotor, it is important that there is a play of 1÷2 mm between the rack and the pinion as shown in Figure 9.**

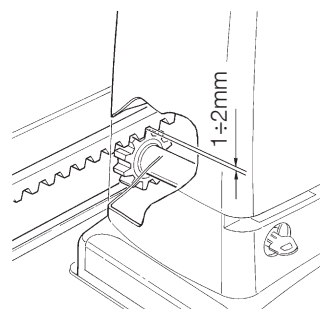

9

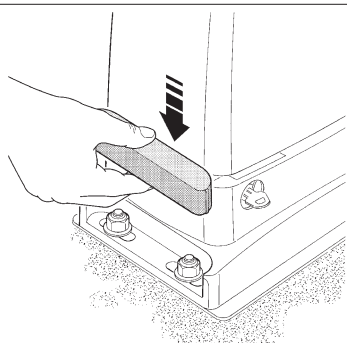

10

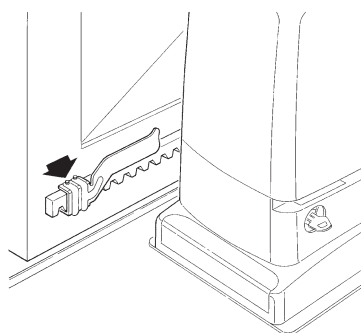

11

8. Slide the leaf, using the pinion as a reference point for the securing the other elements of the rack.
9. Cut away the excess section of the rack.
10. Open and close the gate several times and make sure that the rack is aligned with the pinion with a maximum tolerance of 5 mm. Moreover, check that the play of 1÷2 mm has been respected along the entire length between the pinion and the rack.
11. Thoroughly tighten the two fixing nuts of the gearmotor making sure it is well secured to the ground. Cover the fixing nuts with the relative caps as shown in figure 10.
12. Fix the limit switch bracket as described below (for versions RUN1800P and RUN2500P, fix the bracket as described in para-

graph “3.3 Fixing of the limit switch bracket on versions with inductive limit switch”):

- Manually place the leaf in the open position leaving at least 2-3 cm from the mechanical stop.
  - Slide the bracket along the rack in the opening direction until the limit switch cuts-in. Then bring the bracket forward by at least 2 cm and secure it to the rack with the appropriate stud bolts, as shown in fig. 11.
  - Perform the same operation for the closure limit switch.
13. Secure the gearmotor as described in the paragraph “Release and manual movement” in the Chapter “Instructions and Warnings for Users”.

### 3.3) Fixing of the limit switch bracket on versions with inductive limit switch

The limit switch bracket must be fixed as described below for the RB600P and RB1000P versions that utilise the inductive limit switch.

1. Manually place the leaf in the open position leaving at least 2-3 cm from the mechanical stop.
2. Slide the bracket along the rack in the opening direction until the corresponding LED switches off, as in fig. 12. Then bring the bracket forward by at least 2 cm and secure it to the rack with the appropriate stud bolts.
3. Manually place the leaf in the closed position leaving at least 2-3 cm from the mechanical stop.
4. Slide the bracket along the rack in the closing direction until the corresponding LED switches off. Then bring the bracket forward by at least 2 cm and secure it to the rack with the appropriate stud bolts.

**⚠ Warning: the ideal distance of the bracket for inductive limit switches is between 3 and 8 mm as indicated in fig. 13.**

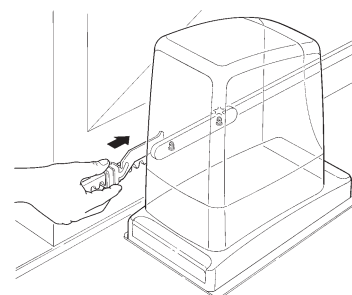

12

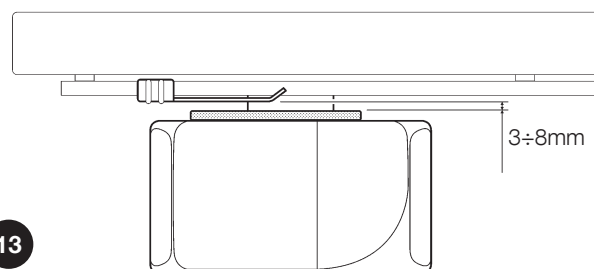

13

### 3.4) Installation of the various devices

If other devices are required, install them following the directions provided in the corresponding instructions. Check this in paragraph "3.6 Description of electrical connections" and the devices which can be connected to the RUN in Figure 2.

### 3.5) Electrical connections

**⚠ Only carry out electrical connections once the electricity supply to the system has been switched off.**

1. Remove the protection cover in order to access the electronic control unit of the RUN. The side screw must be removed, and the cover lifted upwards.
2. Remove the rubber membrane sealing off the two holes for routing the cables; insert the power cable in the smaller hole and all other cables for the various devices in the larger hole, leaving a length of 20÷30 cm longer than necessary. See Table 5 for information regarding the type of cables and Figure 2 for the connections.
3. Use a clamp to collect together and join the cables routed through the larger hole and place the clamp under the cable entry hole. Make a hole in the rubber membrane which is slightly smaller than the diameter of the cables joined by the clamp, and slide the membrane along the cables until it reaches the clamp. Then put the membrane back in its seat. Place a second clamp for collecting the cables which are set just above the membrane.
4. On the smaller membrane, cut a hole slightly smaller than the diameter of the power cable and slide the membrane along the cable until it fits into its seat.
5. Connect the power cable to the relative terminal as shown in figure 14, and secure the cable by means of the collar.
6. Connect up the other cables according to the diagram in Figure 16. The terminals can be removed in order to facilitate this procedure.
7. Once the connections have been completed, secure the cables joined in the clamps to the cable locking rings. The excess aerial cable must be secured to the other cables using another clamp as shown in Figure 15.

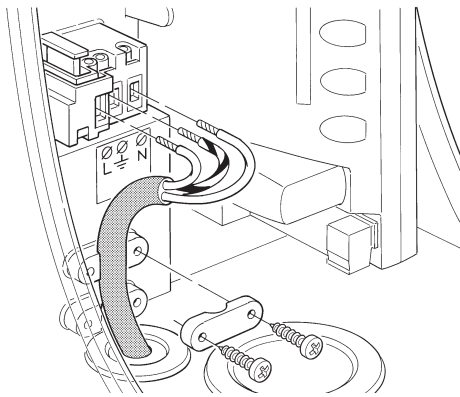

14

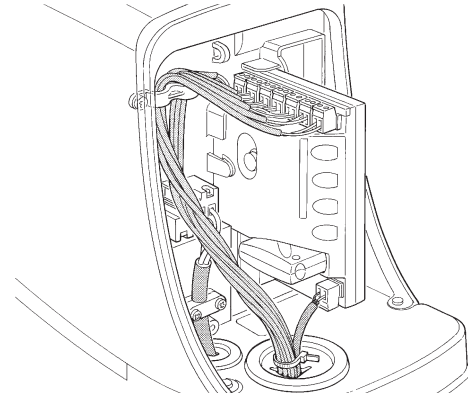

15

LUCYB

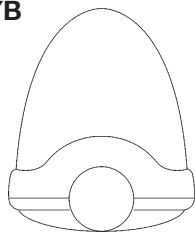

S.C.A.



MOFB

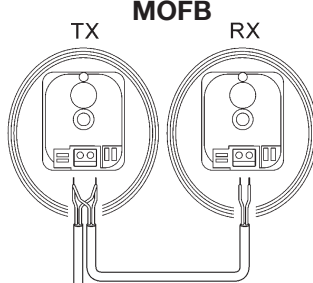

OPEN CLOSE

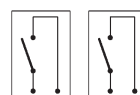

MOSE

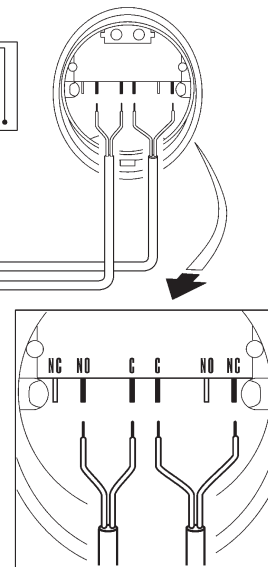

16

See paragraph "7.3.5 RUN in Slave mode" for the connection of 2 motors on opposite leaves.

### 3.6) Description of the electrical connections

The following is a brief description of the electrical connections; for further information please read "7.3 Adding or Removing Devices" paragraph.

**FLASH:** output for one or two "LUCYB" or similar type flashing lights with single 12V maximum 21W bulb.

**S.C.A.:** "Open Gate Indicator" output. An indicator lamp can be connected (24V max. 4W). It can also be programmed for other functions; see paragraph "7.2.3 Level two functions"

**BLUEBUS:** compatible devices can be connected up to this terminal. They are connected in parallel using two wires only, through which both the electricity supply and the communication signals travel. For more useful information about BlueBUS see also Paragraph "7.3.1 BlueBUS".

**STOP:** input for the devices which block or eventually stop the manoeuvre in progress. Contacts like "Normally Closed", "Normally Open" or constant resistance devices can be connected up using

special procedures on the input. For more useful information about STOP see also Paragraph "7.3.2 STOP Input".

**STEP-BY-STEP:** input for devices which control Step-by-Step movement. It is possible to connect "Normally Open" devices up to this input.

**OPEN:** input for devices which control only the opening movement. It is possible to connect "Normally Open" devices up to this input.

**CLOSE:** input for devices which control only the closing movement. It is possible to connect "Normally Open" devices up to this input.

**AERIAL:** connection input for the radio receiver aerial (the aerial is incorporated in LUCY B).

## 4) Final checks and start up

The manufacturers recommend positioning the leaf at approximately mid-stroke before starting the checking and start up phase of the automation. This will ensure the leaf is free to move both during opening and closure.

### 4.1) Choosing the direction

The direction of the opening manoeuvre must be chosen according to the position of the gearmotor with respect to the leaf. If the leaf must move to the left for opening, the selector must be moved towards left as shown in Figure 17; alternatively, if the leaf has to move to the right during opening, the selector must be moved towards the right as shown in Figure 18.

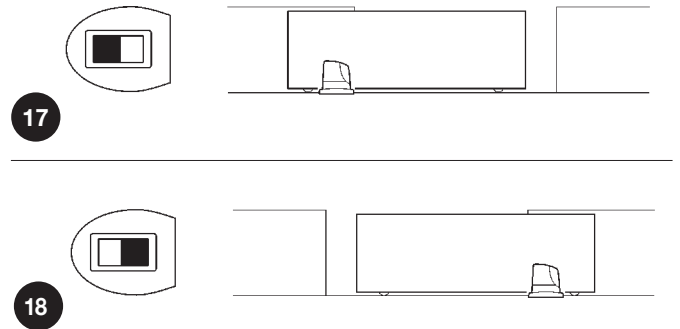

### 4.2) Power supply connection

**⚠ The connection of RUN to the mains must be made by qualified and experienced personnel in possession of the necessary requisites and in full observance of current laws, provisions and standards.**

As soon as RUN is powered up, check the following:

1. Ensure that the "BLUEBUS" LED flashes regularly, with about one flash per second.
2. Ensure that the LED's on the photocells flash (both on TX and RX); the type of flashing is not important as it depends on other factors.

3. Ensure that the flashing light connected to the FLASH output and the lamp LED connected to the "Open Gate Indicator" output are off.

If the above conditions are not satisfied, immediately switch off the power supply to the control unit and check the electrical connections more carefully. Please refer to Chapter "7.6 Troubleshooting" for further information about fault-finding and analysis.

### 4.3) Device self-learning

After connecting up the power supply, the control unit must "learn" the devices connected up to the BLUEBUS and STOP inputs. Before this phase, LEDs L1 and L2 will flash to indicate that device self-learning must be carried out.

1. Press and hold keys **[▲]** and **[Set]**
2. Release the keys when leds L1 and L2 start flashing very quickly (after approx. 3 s)
3. Wait a few seconds for the control unit to finish self-learning the devices
4. When the self-learning stage is complete, the STOP LED must remain on while L1 and L2 must turn off (leds L3 and L4 will eventually start flashing).

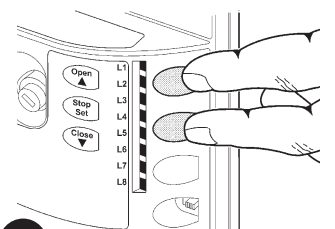

19

The connected devices self-learning stage can be repeated at any time, even after the installation (for example, if a new device is installed); to repeat self-learning see paragraph "7.3.6 Self-learning Other Devices".

#### 4.4) Leaf length self-learning

After self-learning the devices, leds L3 and L4 start flashing; the control unit must self-learn the length of the gate. During this stage, the length of the leaf is measured from the closing limit switch to the opening limit switch. This measurement is required to calculate the deceleration points and the partial opening point.

1. Press and hold keys **[▼]** and **[Set]**
2. Release the keys when the manoeuvre starts (after approx. 3 s)
3. Check the manoeuvre in progress is an opening manoeuvre. Otherwise, press the **[Stop]** key and carefully check Paragraph "4.1 Choosing the Direction", then repeat the process from Point 1.
4. Wait for the control unit to open the gate until it reaches the opening limit switch; the closing manoeuvre will start immediately afterwards.
5. Wait for the control unit to close the gate.

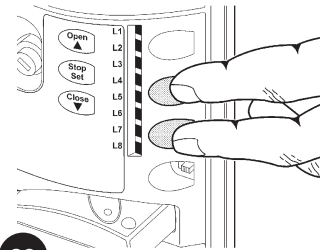

20

If the above conditions are not satisfied, immediately switch off the power supply to the control unit and check the electrical connections more carefully. For more useful information see also chapter "7.6 Troubleshooting".

#### 4.5) Checking gate movements

On completion of self-learning of the length of the leaf, a number of manoeuvres should be carried out to ensure correct gate travel

1. Press the **[Open]** key to open the gate. Check that gate opening occurs regularly, without any variations in speed. The leaf must only slow down and stop when it is between 70 and 50 cm from the opening mechanical stop. Then, at 2÷3 cm from the mechanical opening stop the limit switch will trigger.
2. Press the **[Close]** key to close the gate. Check that gate closing occurs regularly, without any variations in speed. The leaf must only slow down and stop when it is between 70 and 50 cm from the closing mechanical stop. Then, at 2÷3 cm from the mechanical closing stop the limit switch will trigger.
3. During the manoeuvre, check that the flashing light flashes at a speed of 0.5 seconds on and 0.5 seconds off. If present, also check the flashes of the light connected to the open gate indicator terminal: slow flashes during opening, quick flashes during closing.
4. Open and close the gate several times to make sure that there are no points of excessive friction and that there are no defects in the assembly or adjustments.
5. Check that the fixture of the RUN gearmotor, the rack and the limit switch brackets are solid, stable and suitably resistant, even if the gate accelerates or decelerates sharply.

#### 4.6) Preset functions

The RUN control unit has a number of programmable functions. These functions are set to a configuration which should satisfy most automations. However, the functions can be modified at any time by means of a special programming procedure.

Please refer to paragraph "7.2 Programming" for further information.

#### 4.7) Radio receiver

An "SM" connector for SMXI or SMXIS type optional radio receivers is fitted on the control unit to enable remote control of RUN.

Disconnect the power supply and follow the operations indicated in fig. 21 to install the radio receiver. The association between the SMXI and SMXIS radio receiver output and the command performed by RUN is described in table 6:

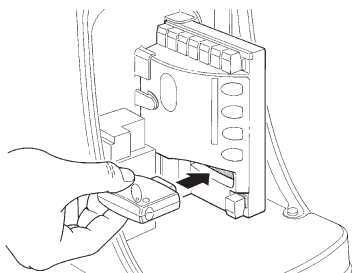

21

For further information, consult the radio receiver instruction manual.

**Table 6: commands with transmitter**

Output N°1	STEP-BY-STEP command
Output N°2	"Partial opening" command
Output N°3	"Open" command
Output N°4	"Close" command

### 5) Testing and commissioning

This is the most important stage in the automation system installation procedure in order to ensure maximum safety levels. Testing can also be adopted as a method of periodically checking that all the various devices in the system are functioning correctly.

**⚠ Testing of the entire system must be performed by qualified and experienced personnel who must establish which tests to conduct on the basis of the risks involved, and verify the compliance of the system with applicable regulations, legislation and standards, in particular with all the provisions of EN standard 12445 which establishes the test methods for automation systems for gates.**

### 5.1) Testing

Each component of the system, e.g. safety edges, photocells, emergency stop, etc. requires a specific testing phase. We therefore recommend observing the procedures shown in the relative instruction manuals. To test RUN, proceed as follows:

1. Ensure that the instructions outlined in this manual and in particular in chapter 1 "WARNINGS" have been observed in full;
2. Release the gearmotor as shown in "Release and manual movement" paragraph in chapter "Instructions and Warnings for users of the RUN gearmotor"
3. Make sure you can move the door manually both during opening and closing with a force of max. 390N (40 kg approx.).
4. Lock the gearmotor.
5. Using the control or stop devices (key-operated selector switch, control buttons or radio transmitter) test the opening, closing and

stopping of the gate and make sure that the leaves move in the intended direction.

6. Ensure correct operation of all safety devices, one by one (photocells, sensitive edges, emergency stop, etc.) and check that the gate performs as it should. In particular, each time a device is activated the "BlueBUS" LED on the control unit flashes 2 times quickly, confirming that the control unit recognizes the event.
7. If the hazardous situations caused by the movement of the leaf have been safeguarded by limiting the force of impact, the impact force must be measured according to EN Standard 12445. If the adjustment of the "obstacle detection sensitivity" and control of the "motor torque" are used to assist the system for the reduction of the impact force, try to find the adjustment to obtain optimal results.

### 5.2) Commissioning

Commissioning can take place only after all the testing phases of the RUN and the other devices have been completed successfully. It is not permissible to execute partial commissioning or to enable use of the system in makeshift conditions.

1. Prepare and store for at least 10 years the technical documentation for the automation, which must include at least the following: assembly drawing of the automation, wiring diagram, analysis of hazards and solutions adopted, manufacturer's declaration of conformity of all the devices installed (for RUN use the annexed CE declaration of conformity); copy of the instruction manual and maintenance schedule of the automation.
2. Affix a dataplate on the gate providing at least the following data: type of automation, name and address of manufacturer (person responsible for the "commissioning"), serial number, year of manufacture and "CE" marking.

3. Post a permanent label or sign near the gate detailing the operations for the release and manual manoeuvre.
4. Prepare the declaration of conformity of the automation system and deliver it to the owner.
5. Prepare the "Instructions and warnings for the use of the automation system" and deliver it to the owner.
6. Prepare the maintenance schedule of the automation system and deliver it to the owner; this must provide all directions regarding the maintenance of the single automation devices.
7. Before commissioning the automation system inform the owner in writing regarding residual risks and hazards (e.g. in the "Instructions and warnings for the use of the automation system").

## 6) Maintenance and Disposal

This charter provides information about how to draw up a maintenance schedule, and the disposal of RUN.

### 6.1) Maintenance

The automation must undergo maintenance work on a regular basis, in order to guarantee prolonged lifetime; to this end RUN has a manoeuvre counter and maintenance warning system; see paragraph "7.4.4 Maintenance warning".

**⚠ The maintenance operations must be performed in strict compliance with the safety directions provided in this manual and according to the applicable legislation and standards.**

If other devices are present, follow the directions provided in the corresponding maintenance schedule.

1. RUN requires scheduled maintenance work every 6 months or 20,000 manoeuvres (max.) after previous maintenance.
2. Disconnect all power supplies.
3. Check for any deterioration of the components which form the automation, paying particular attention to erosion or oxidation of the structural parts. Replace any parts which are below the required standard.
4. Check the wear and tear on the moving parts: pinion, rack and the leaf components; if necessary replace.
5. Connect the electric power sources up again, and carry out the testing and checks stated in Paragraph "5.1 Testing".

### 6.2) Disposal

As in the case of installation, at the end of the product lifetime, disposal procedures must be carried out by qualified personnel. This product comprises various types of materials, some of which can be recycled while others must be disposed of. Check information on the recycling and disposal procedures according to local legislation for this product category.

**⚠ Some parts of the product may contain pollutant or hazardous substances; if disposed of into the environment these may constitute a serious risk of damage to the environment and public health.**

As indicated by the symbol in figure 22 never dispose of this product in domestic waste. Apply classified waste collection procedures for disposal in accordance with local regulations or return the product to the retailer when purchasing a new model.

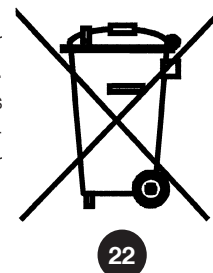

Local regulations may envisage serious fines in the event of illegal disposal of this product.

## 7) Additional information

Programming, personalisation and how to look for and deal with faults on the RUN will be dealt with in this chapter.

### 7.1) Programming keys

The RUN control unit feature three keys that can be used to command the control unit both during tests and programming:

<b>Open</b> ▲	The "OPEN" key enables the user to control the opening of the gate or move the programming point upwards.
<b>Stop Set</b>	The "STOP" key enables the user to stop the manoeuvre. If pressed down for more than 5 seconds it enables the user to enter programming.
<b>Close</b> ▼	The "CLOSE" key enables the user to control the closing of the gate or move the programming point downwards.

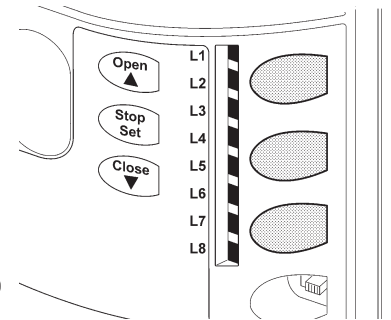

### 7.2) Programming

A number of programmable functions are available on the RUN control unit. The functions are adjusted using 3 keys set on the control unit: [▲] [Set] [▼] and are used by means of 8 LEDs: L1...L8.

The programmable functions available on RUN are set out on 2 levels:

**Level one:** the functions can be adjusted in modes ON-OFF (active or inactive). In this case, each of the LEDs L1...L8 indicates a function. If the LED is on, the function is active, if off the function is inactive. See Table 7.

**Level two:** the parameters can be adjusted on a scale of values (from 1 to 8). In this case, each of the LEDs L1...L8 indicates the value set (there are 8 possible settings). Please refer to Table 9.

#### 7.2.1) Level one functions (ON-OFF functions)



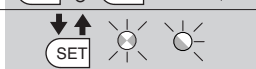

**Table 7: programmable function list: level one:**

Led	Function	Description
L1	Automatic Closing	This function causes the door to close automatically after the programmed time has lapsed. The factory set Pause Time is 30 seconds, but can be changed to 5, 15, 30, 45, 60, 80, 120 or 180 seconds. If the function is inactive, functioning will be "semi-automatic".
L2	Close After Photo	This function enables the gate to be kept open for the necessary transit time only. In fact the "Photo" always causes an automatic closure with a pause time of 5s (regardless of the programmed value). The action changes depending on whether the "Automatic closing" function is active or not. <b>When "Automatic Closing" is inactive:</b> The gate always arrives to the totally open position (even if the Photo disengages first). Automatic closing with a pause of 5s occurs when the Photo is disengaged. <b>When "Automatic Closing" is active:</b> The opening manoeuvre stops immediately after the photocells have disengaged. After 5 seconds, the gate will begin to close automatically. The "Close after photo" function is always disabled in manoeuvres interrupted by a Stop command. If the "Close after photo" function is inactive the pause time is that which has been programmed or there is no automatic closing if the function is inactive.
L3	Always Close	The "Always Close" function is activated, causing closure when an open gate is detected on return of power. A light will flash for 5 seconds before the manoeuvre starts, for safety purposes. If the function is inactive when the power supply returns, the gate will remain stationary.
L4	Deceleration	On activation of this function, a deceleration phase is activated at the end of the opening or closing manoeuvre. Deceleration speed corresponds to approx. 60% of the nominal speed. <b>Caution:</b> during deceleration the motor develops only half of the nominal torque; the deceleration phase is not possible on heavyweight gates or those requiring maximum torque. If deceleration is not active the speed remains constant throughout the manoeuvre.
L5	Peak	On activation of this function, gradual acceleration at the start of each manoeuvre is disabled; this enables the maximum peak force and is useful in situations with high levels of static friction, such as in the event of snow or ice blocking the leaf. If Peak is not active the manoeuvre starts with a gradual acceleration phase.
L6	Pre-flashing	With the pre-flashing function, a 3 second pause is added between the flashing light switching on and the beginning of the manoeuvre in order to warn the user in advance of a potentially dangerous situation. If pre-flashing is inactive, the flashing light will switch on when the manoeuvre starts.
L7	"Close" becomes "Partial Open"	By activating this function all "close" commands ("CLOSE" input or radio command "close") activate a partial opening manoeuvre (see LED L6 on table 9).
L8	"Slave" mode	By activating this function RUN becomes "Slave": in this way it is possible to synchronise the functioning of two motors on opposite leaves where one motor functions as Master and the other as Slave; for further information see paragraph "7.3.5 RUN in "Slave" mode".

During the normal functioning of the RUN, LEDs L1...L8 will either be on or off depending on the state of the function they represent. For example, L1 will be on if the "Automatic Closing" function is active.

### 7.2.2 Level one programming (ON-OFF functions)

Level 1 functions are all factory set to "OFF". However, they can be changed at any time as shown in Table 8. Follow the procedure carefully, as there is a maximum time of 10 seconds between pressing one key and another. If a longer period of time lapses, the procedure will finish automatically and memorize the modifications made up to that stage.

Table 8: changing ON-OFF functions		Example
1.	Press and hold key <b>[Set]</b> (approx. 3 s)	
2.	Release the <b>[Set]</b> key when L1 LED starts flashing	
3.	Press keys <b>[▲]</b> or <b>[▼]</b> to move the flashing LED onto the LED representing the function to be changed	
4.	Press the <b>[Set]</b> key to change the state of the function (short flashing = OFF; long flashing = ON)	
5.	Wait 10 seconds before leaving the programme to allow the maximum time to lapse.	

Note: Points 3 and 4 can be repeated during the same programming phases in order to set other functions to ON or OFF

### 7.2.3 Level two functions (adjustable parameters)

Table 9: programmable function list: level two				
Input LED	Parameter	Led (level)	Value	Description
L1	Pause Time	L1	5 Seconds	Adjusts the pause time, i.e. the time which lapses before automatic closure. This will only have an effect if automatic closing is active.
		L2	15 Seconds	
		L3	30 Seconds	
		L4	45 Seconds	
		L5	60 Seconds	
		L6	80 Seconds	
		L7	120 Seconds	
		L8	180 Seconds	
L2	Step-by-step Function	L1	Open - stop - close - stop	Manages the sequence of controls associated with the Step-by-Step input or to the 1st radio command.
		L2	Open - stop - close - open	
		L3	Open - close - open - close	
		L4	Apartment block	
		L5	Apartment block (more than 2" generates stop)	
		L6	Step-by-step 2 (less than 2" generates partial open)	
		L7	Dead man	
		L8	Opening in semi-automatic mode, closing in dead man mode	
L3	Obstacle detection sensitivity	L1	Very high sensitivity (lightweight gates)	Controls obstacle detection sensitivity. Take care that sensitivity is also influenced by the force of the motor (see L5); the motor force should always be adjusted beforehand, to enable correct settings of obstacle detection sensitivity.
		L2	Very high sensitivity	
		L3	High sensitivity	
		L4	Medium sensitivity	
		L5	Medium-low sensitivity	
		L6	Low sensitivity	
		L7	Very low sensitivity	
		L8	Very low sensitivity (heavyweight gates)	
L4	Open gate indicator output	L1	Gate Open Indicator function	Adjust the function associated with the open gate indicator output (regardless of the associated function, when active, it supplies a voltage of 24V -30 +50% with maximum power of 4W).
		L2	Active if leaf closed	
		L3	Active if leaf open	
		L4	Active with radio output 2	
		L5	Active with radio output 3	
		L6	Active with radio output 4	
		L7	Maintenance indicator	
		L8	Electric lock	
L5	Motor force control	L1	Set at 40%	After start-up of the motor, set the force to adapt it to the weight of the gate. The control system also measures the ambient temperature, increasing force automatically in the event of particularly low temperatures.
		L2	Set at 50%	
		L3	Set at 60%	
		L4	Set at 80%	
		L5	Set at 100%	
		L6	Semiautomatic 1=40÷100% (1)	
		L7	Semiautomatic 2=60÷100% (1)	
		L8	Automatic = 0÷100% (2)	



Input LED	Parameter	Led (level)	Value	Description
L6	Partial Open	L1	0,5 mt	The measurement of the partial opening. Partial opening can be controlled with the 2nd radio command or with "CLOSE", if the "Close" function is present, this becomes "Partial open".
		L2	1 mt	
		L3	1,5 mt	
		L4	2 mt	
		L5	2,5 mt	
		L6	3 mt	
		L7	3,4 mt	
		L8	4 mt	
L7	Maintenance warning	L1	Automatic (based on seriousness of manoeuvres)	Adjusts the number of manoeuvres after which it signals the maintenance request of the automation (see paragraph "7.4.4 Maintenance warning").
		L2	2.000	
		L3	4.000	
		L4	7.000	
		L5	10.000	
		L6	15.000	
		L7	20.000	
		L8	30.000	
L8	Fault list	L1	Manoeuvre 1 result (most recent)	The type of defect that has occurred in the last 8 manoeuvres can be established (see paragraph "7.6.1 Malfunctions archive").
		L2	Manoeuvre 2 result	
		L3	Manoeuvre 3 result	
		L4	Manoeuvre 4 result	
		L5	Manoeuvre 5 result	
		L6	Manoeuvre 6 result	
		L7	Manoeuvre 7 result	
		L8	Manoeuvre 8 result	

Note: "■" represents the factory setting

Note (1): Automatically regulates the force required, maintaining a minimum guaranteed force level.







Note (2): Automatically regulates the force required.

All parameters can be adjusted as required without any contraindications, only the "Obstacle detection sensitivity" and "Motor force control" may require special attention:

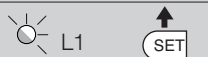
- Use of high force values are not recommended to compensate for the fact that the leaf has anomalous points of friction; excessive force may impair the safety system and damage the leaf.
- If the "Obstacle detection sensitivity" is used in support of the system for impact force reduction, after each adjustment the force measurement procedure must be performed, as envisaged by standard EN 12445.
- Wear and atmospheric conditions that influence movement of the gate; force settings should be checked periodically.

### 7.2.4) Level two programming (adjustable parameters)





The adjustable parameters are factory set as shown in the table 9, with: "■" However, they can be changed at any time as shown in Table 10. Follow the procedure carefully, as there is a maximum time of 10 seconds between pressing one key and another. If a longer period of time lapses, the procedure will finish automatically and memorize the modifications made up to that stage.

Tabella 10: changing the adjustable parameters		Example
1.	Press and hold key [Set] (approx. 3 s)	 3s
2.	Release the [Set] key when L1 LED starts flashing	 L1
3.	Press key [▲] or [▼] to move the flashing LED onto the input LED representing the parameter to be changed	
4.	Press the key [Set] and hold it down during step 5 and 6	
5.	Wait approx. 3 seconds, after which the LED representing the current level of the parameter to be modified will light up.	
6.	Press key [▲] or [▼] to move the LED representing the parameter value.	
7.	Release the key [Set]	
8.	Wait 10 seconds before leaving the programme to allow the maximum time to lapse.	 10s

Note: Points 3 to 7 can be repeated during the same programming phase in order to set other parameters

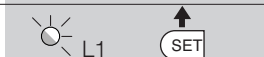
### 7.2.5) Level one programming example (ON-OFF functions)

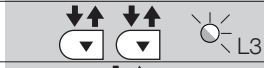









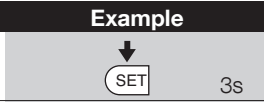

The sequence to follow in order to change the factory settings of the functions for activating “Automatic Closing” (L1) and “Always close” (L3) have been included as examples.).

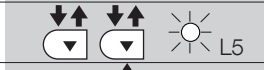
Table 11: Level one programming	Example
1. Press and hold <b>[Set]</b> (approx. 3 s)	
2. Release the <b>[Set]</b> key when L1 LED starts flashing	
3. Press <b>[Set]</b> once to change the state of the function associated with L1 (Automatic Closing). LED L1 will now flash with long flashes.	
4. Press <b>[▼]</b> twice to move the flashing LED to LED L3	
5. Press the <b>[Set]</b> key once to change the state of the function associated with L3 (Always Close). LED L3 will now flash with long flashes.	
6. Wait 10 seconds before leaving the programme to allow the maximum time to lapse.	

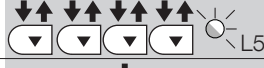
Once these operations have been completed, LEDs L1 and L3 must remain on to indicate that the “Automatic Closing” and the “Always Close” functions are active.

### 7.2.6) Level two programming example (adjustable parameters)

The example shows the sequence to follow to change the factory settings of parameters and increase the “Pause Time” to 60 seconds (input on L1 and level on L5) and reduce the “Motor Torque” of 60% (input on L5 and level on L3).

Table 12: Level two programming	Example
1. Press and hold <b>[Set]</b> (approx. 3 s)	
2. Release <b>[Set]</b> when L1 LED starts flashing	
3. Press and hold <b>[Set]</b> during steps 4 and 5	
4. Wait approx. 3 seconds until LED L3, representing the current level of the “Pause Time” will light up	
5. Press <b>[▼]</b> twice to move the LED which is lit to LED L5, which represents the new “Pause Time” value	
6. Release <b>[Set]</b>	
7. Press <b>[▼]</b> four times to move the flashing LED to LED L5	
8. Press and hold <b>[Set]</b> during steps 9 and 10	
9. Wait approx. 3 seconds until LED L5, representing the current level of the “Motor Torque” will light up	
10. Press <b>[▲]</b> twice to move the LED which is lit to LED L3, which represents the new “Motor Torque” value	
11. Release <b>[Set]</b>	
12. Wait 10 seconds before leaving the programme to allow the maximum time to lapse.	

### 7.3) Adding or removing devices

Devices can be added to or removed from the RUN automation system at any time. In particular, various devices types can be connected to “BlueBUS” and “STOP” input as explained in the following paragraphs.

**After adding or removing any devices, the automation system must go through the self-learning process again according to the directions contained in paragraph 7.3.6 “Device self-learning”.**

#### 7.3.1) BlueBUS

BlueBUS technology enables the connection of compatible devices using only two wires which carry both the power supply and the communication signals. All the devices are connected in parallel on the 2 wires of the BlueBUS itself. It is not necessary to observe any polarity; each device is individually recognized because a univocal address is assigned to it during installation. Photocells, safety devices, control keys, signalling lights etc. can be connected to BlueBUS.

The RUN control unit recognizes all the connected devices individually through a suitable self-learning process, and can detect all the possible abnormalities with absolute precision. For this reason, each time a device connected to BlueBUS is added or removed, the control unit must go through the self-learning process; see paragraph 7.3.6 “Self-learning Other Devices”.

### 7.3.2) STOP input

STOP is the input that causes the immediate interruption of the manoeuvre (with a short reverse run). Devices with output featuring normally open “NO” contacts and devices with normally closed “NC” contacts, as well as devices with 8,2kΩ constant resistance output, such as sensitive edges, can be connected to this input.

During the self-learning stage the control unit, as in the case of BlueBUS, recognizes the type of device connected to the STOP input (see paragraph 7.3.6 “Self-learning Other Devices”); subsequently it commands a STOP whenever a change occurs in the recognized status.

Multiple devices, even of different type, can be connected to the STOP input if suitable arrangements are made:

- Any number of NO devices can be connected to each other in parallel.
- Any number of NC devices can be connected to each other in series.

- Two devices with 8.2KΩ constant resistance output can be connected in parallel; if necessary, multiple devices must be connected “in cascade” with a single 8.2KΩ termination resistance.
- It is possible to combine Normally Open and Normally Closed by making 2 contacts in parallel with the warning to place an 8.2KΩ resistance in series with the Normally Closed contact (this also makes it possible to combine 3 devices: Normally Open, Normally Closed and 8,2kΩ).

**⚠ If the STOP input is used to connect devices with safety functions, only the devices with 8,2kΩ constant resistance output guarantee the fail-safe category 3 according to EN standard 954-1.**

### 7.3.3) Photocells

By means of addressing using special jumpers, the “BlueBUS” system enables the user to make the control unit recognise the photocells and assign them with a correct detection function. The addressing procedure must be performed both on TX and RX (setting the jumpers in the same way) making sure there are no other pairs of photocells with the same address.

In an automation for sliding gates, RUN enables installation of the photocells as shown in Figure 24.

Each time a photocell is added or removed the control unit must go through the self-learning process; see paragraph 7.3.6 “Self-learning Other Devices”.

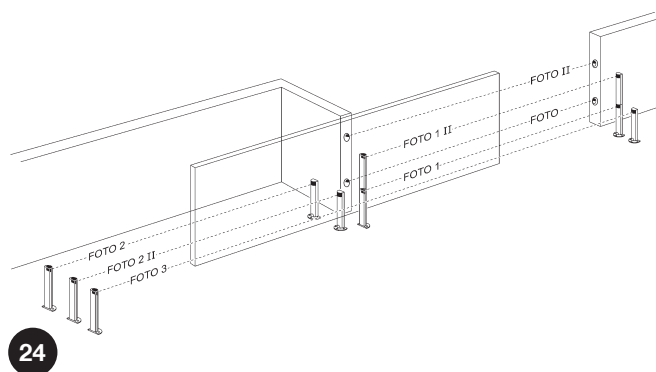

**Table 13: Photocell addressing**

Photocell	Jumpers	Photocell	Jumpers
<b>PHOTOCELL</b> External photocell h=50 cm activated when gate closes		<b>PHOTOCELL 2</b> External photocell activated when gate opens	
<b>PHOTOCELL II</b> External photocell h=100 cm activated when gate closes		<b>PHOTOCELL 2 II</b> Internal photocell activated when gate opens	
<b>PHOTOCELL 1</b> Internal photocell h = 50 cm activated when gate closes		<b>PHOTOCELL 3</b> Single photocell for entire automation system	
<b>PHOTOCELL 1 II</b> Internal photocell h=100 cm activated when gate closes		<p><b>⚠ In the case of the installation of PHOTO 3 and PHOTO II together, the position of the photocell elements (TX-RX) must comply with the provisions contained in the photocell instruction manual</b></p>	

### 7.3.4) FT210B Photo-sensor

The FT210B photo-sensor combines a force limiting device (type C in accordance with the standard EN1245) and a presence detector which detects the presence of obstacles on an optical axis between the TX transmitter and the RX receiver (type D in accordance with the standard EN12453). The sensitive edge status signals on the FT210 photo-sensor are transmitted by means of the photocell beam, integrating the two systems in a single device. The transmitting part is positioned on the mobile leaf and is powered by a battery thereby eliminating unsightly connection systems; the consumption of the battery is reduced by special circuits guaranteeing a duration of up to 15 years (see the estimation details in the product instructions).

By combining a FT210B device with a sensitive edge (TCB65 for example) the level of security of the “primary edge”, required by the EN12453 standard for all “types of use” and “types of activation”, can be attained.

The FT210B is safe against individual faults when combined to a “resistive” type (8,2Kohm) sensitive edge. It features a special anti-collision circuit that prevents interference with other detectors, even if not synchronised, and allows additional photocells to be fitted; for example, in cases where there is a passage of heavy vehicles and a second photocell is normally placed at 1 m from the ground.

See the FT210B instruction manual for further information concerning connection and addressing methods.

### 7.3.5) RUN in "Slave" mode

When correctly programmed and connected, RUN can function in "Slave" mode; this type of function is used when 2 opposite gates need to be automated with the synchronised movement of the two leaves. In this mode RUN works as Master commanding the movement, while the second RUN acts as Slave, following the commands transmitted by the Master (all RUN are Masters when leaving the factory).

To configure RUN as a Slave level one "Slave mode" must be activated (see table 7).

The connection between RUN Master and RUN Slave is made via BlueBus.

**⚠ In this case the polarity of the connections between the two RUN must be observed as illustrated in fig. 26 (the other devices remain with no polarity).**

Follow the operations below to install 2 RUN in the Master and Slave mode:

- Install the 2 motors as indicated in fig. 25. It is not important which motor is to function as Slave or Master; when choosing, one must consider the convenience of the connections and the fact that the Step-by-Step command of the Slave only allows the Slave leaf to be opened fully.

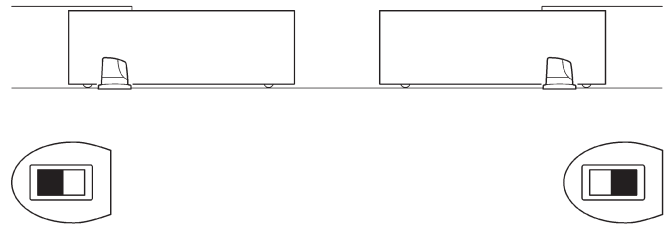

25

- Connect the 2 motors as shown in fig. 26.
- Select the opening direction of the 2 motors as shown in fig. 25 (see also paragraph "4.1 Choosing the direction").
- Supply power to the 2 motors.
- Program the "Slave mode" on the RUN Slave (see table 7).
- Perform the device self-learning on the RUN Slave (see paragraph "4.3 Self-learning devices").
- Perform the device self-learning on the RUN Master (see paragraph "4.3 Self-learning devices").
- Perform the self-learning of the leaf length on the RUN Master (see paragraph "4.4 Leaf length self-learning").

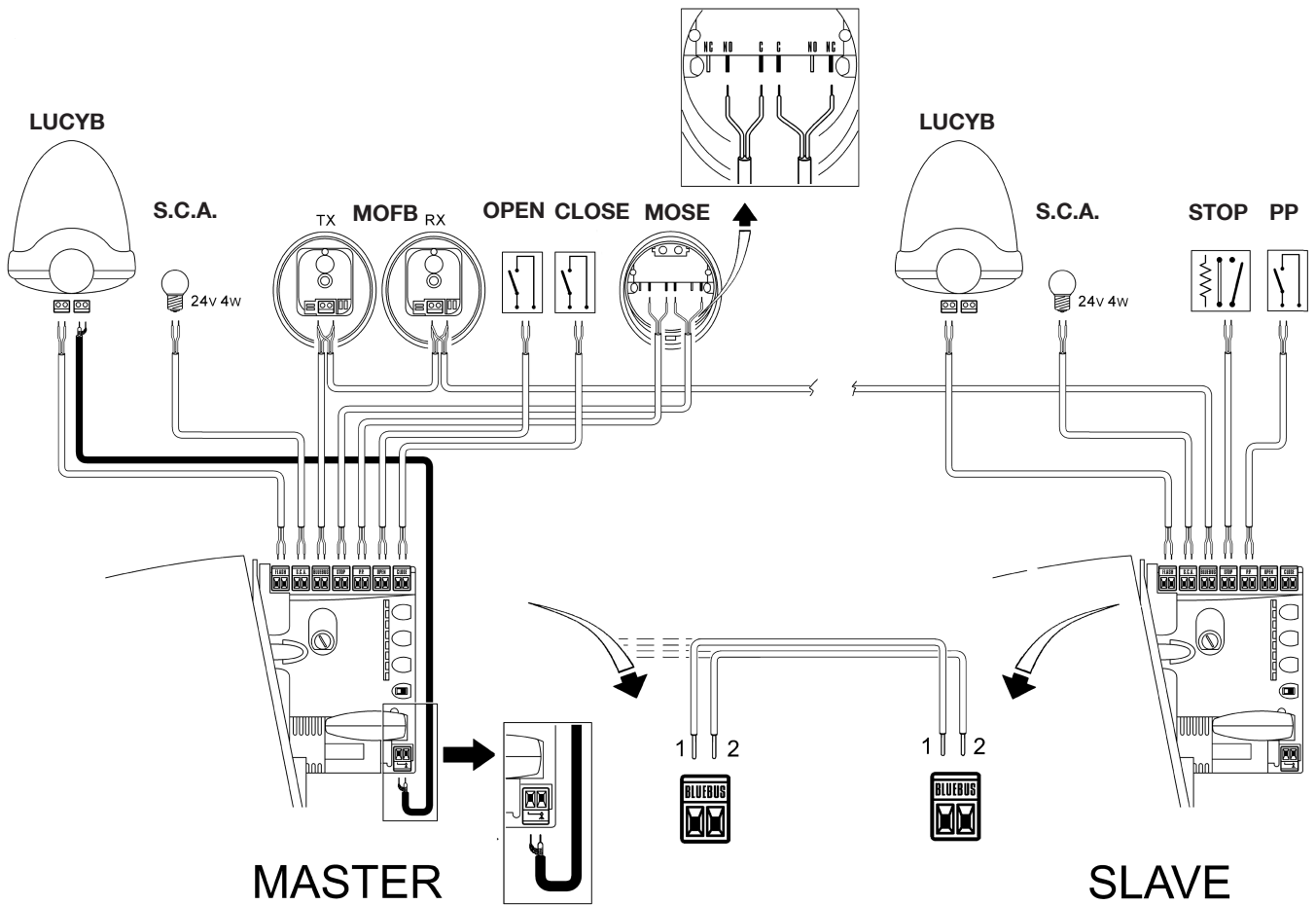

26

When connecting 2 RUN in the Master-Slave mode, strictly observe the following:

- All devices must be connected to the RUN Master (as in fig. 26) including the radio receiver.
- All programming performed on RUN Slave is ignored (that on RUN Master overrides the others) except for those mentioned in table 14.

**Table 14: RUN Slave programming independently from RUN Master**

Level one functions (ON-OFF functions)	Level two functions (adjustable parameters)
Stand-By	Obstacle detection sensitivity
Peak	Open Gate Indicator output
Slave Mode	Motor torque control
	Fault list

On Slave it is possible to connect:

- A flashing light (Flash)
- An open gate indicator (S.C.A.)
- A sensitive edge (Stop)
- A command device (Step by Step) that controls the complete opening of the Slave leaf only.
- The Open and Close inputs are not used on the Slave

**7.3.6) Self-learning Other Devices**

Normally the self-learning of the devices connected to the BlueBUS and the STOP input takes place during the installation stage. However, if new devices are added or old ones removed, the self-learning process can be repeated by proceeding as shown in Figure 15.

**Table 15: Self-learning Other Devices**

	Example
1. Press and hold keys <b>[▲]</b> and <b>[Set]</b>	
2. Release the keys when leds L1 and L2 start flashing very quickly (after approx. 3 s)	
3. Wait a few seconds for the control unit to finish self-learning the devices	
4. When the self-learning stage is complete, leds L1 and L2 will turn off, the STOP LED must remain on, while leds L1...L8 will light up according to the status of the relative ON-OFF functions.	

**▲ After adding or removing any devices, the automation system must be tested again according to the instructions in paragraph 5.1 “Testing”.**

**7.4) Special functions**

**7.4.1) “Always open” Function**

The “Always open” function is a control unit feature which enables the user to control an opening manoeuvre when the “Step-by-Step” command lasts longer than 2 seconds. For example, this is useful for connecting a timer contact to the “Step-by-Step” terminal in order to keep

the gate open for a certain length of time. This feature is valid with any kind of “Step-by-Step” input programming, except for “Apartment block 2”. Refer to the “Step-by-Step Function” parameter in Table 9.

**7.4.2) “Move anyway” function**

In the event that one of the safety devices is not functioning properly or is out of use, it is still possible to command and move the gate in “Dead man” mode.

Please refer to the Paragraph “Control with safety devices out of order” in the enclosure “Instructions and Warnings for users of the RUN gearmotor” for further information.

**7.4.3) Heating and cooling control system**

RUN is equipped with a sophisticated system for the control of the motor temperature. The internal value of RUN is read by a special sensor and used for the management of the conditioning system, to enable heating of the motor when external temperatures fall below a

threshold of around 0°C (if the “heating” function is enabled via the remote programming unit “OperaView”); or enable accelerated cooling of the motor when temperatures exceed a value of around 40°C.

**7.4.4) Maintenance warning**

With RUN the user is notified when the automation requires a maintenance inspection. The number of manoeuvres after the warning can be selected from 8 levels, by means of the “Maintenance warning” adjustable parameter (see table 9). Adjustment level 1 is “automatic” and takes into consideration the severity of the manoeuvre, this being the force and duration of the manoeuvre, while the other adjustments are established according to the number of manoeuvres.

The maintenance request warning is by means of the Flashing light or on the Open Gate indicator output when this is programmed as a “Maintenance Indicator” (see table 9).







The flashing light “Flash” and the maintenance light give the signals indicated in table 16, based on the number of manoeuvres performed according to the limits programmed.

**Table 16: maintenance warning with Flash and maintenance light**

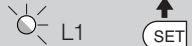
Number of manoeuvres	Flash signal	Maintenance indicator signal
Below 80% of limit	Normal (0.5s on, 0.5s off)	Lit for 2s at start of opening
Between 81 and 100% of limit	At start of manoeuvre remains lit for 2s then proceeds as normal	Flashes throughout manoeuvre
Over 100% of limit	At start and end of manoeuvre remains lit for 2s then proceeds as normal	Flashes continuously







### Check of number of manoeuvres performed

The number of manoeuvres performed as a percentage of the set limit can be verified by means of the "Maintenance warning" function. Follow the indications in table 17 for this check.

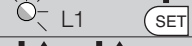
Table 17: check of the number of manoeuvres performed		Example
1.	Press and hold <b>[Set]</b> (approx. 3 s)	 3s
2.	Release <b>[Set]</b> when led L1 starts flashing	
3.	Press key <b>[▲]</b> or <b>[▼]</b> to move the flashing LED onto the input LED L7 representing the "Maintenance warning" parameter	
4.	Press and hold <b>[Set]</b> during steps 5, 6 and 7	
5.	Wait approx. 3 seconds, after which the LED representing the current level of the parameter "Maintenance warning" will light up.	
6.	Press and immediately release the <b>[▲]</b> and <b>[▼]</b> keys.	
7.	The LED that corresponds to the selected level flashes. The number of flashes indicates the percentage of manoeuvres performed (in multiples of 10%) in relation to the set limit. For example: with the maintenance warning set on L6 being 10000, 10% is equal to 1000 manoeuvres; if the LED flashes 4 times, this means that 40% of the manoeuvres have been reached (between 4000 and 4999 manoeuvres). The LED will not flash if 10% of the manoeuvres has not yet been reached.	
8.	Release the key <b>[Set]</b>	

### Manoeuvre counter reset

After the maintenance of the system has been performed the manoeuvre counter must be reset. Proceed as described in table 18.

Table 18: manoeuvre counter reset		Example
1.	Press and hold <b>[Set]</b> (approx. 3 s)	 3s
2.	Release <b>[Set]</b> when led L1 starts flashing	
3.	Press key <b>[▲]</b> or <b>[▼]</b> to move the flashing LED onto the input LED L7 representing the "Maintenance warning" parameter	
4.	Press and hold <b>[Set]</b> during steps 5 and 6	
5.	Wait approx. 3 seconds, after which the LED representing the current level of the parameter "Maintenance warning" will light up.	
6.	Press and hold keys <b>[▲]</b> and <b>[▼]</b> , for at least 5 seconds and then release. The LED that corresponds to the selected level flashes rapidly indicating that the manoeuvre counter has been reset.	
7.	Release the key <b>[Set]</b> .	

### 7.5) Connection of Other Devices

If the user needs to feed external devices such as a proximity reader for transponder cards or the illumination light of the key-operated selector switch, it is possible to tap power as shown in Figure 27. The power supply voltage is 24Vdc -30% - +50% with a maximum available current of 100mA.

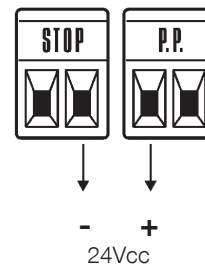

## 7.6) Troubleshooting

Table 19 contains instructions to help solving malfunctions or errors that may occur during the installation stage or in case of failure.

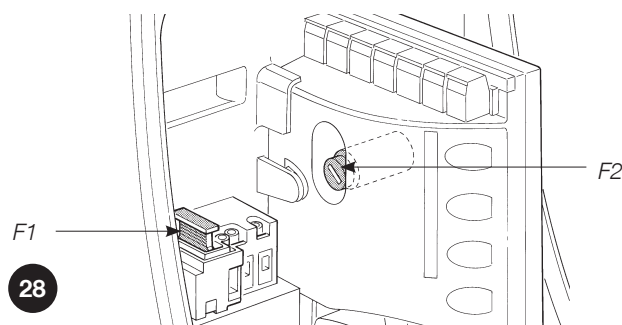

**Table 19: Troubleshooting**

Symptoms	Recommended checks
The radio transmitter does not control the gate and the LED on the transmitter does not light up.	Check to see if the transmitter batteries are discharged, if necessary replace them
The radio transmitter does not control the gate but the LED on the transmitter lights up	Check to see if the transmitter has been memorised correctly in the radio receiver
No manoeuvre starts and the “BlueBUS” LED does not flash	Check that RUN is powered by a 230V mains supply. Check to see if the fuses are blown; if necessary, locate the reason for the failure and then replace the fuses with others of the same current rating and characteristics.
No manoeuvre starts and the flashing light is off	Make sure that the command is actually received. If the command reaches the STEP-BY-STEP input, the corresponding “STEP-BY-STEP” LED must light up; if you are using the radio transmitter, the “BlueBus” LED must make two quick flashes.
No manoeuvre starts and the flashing light flashes a few times	Count the flashes and check the corresponding value in table 21
The manoeuvre starts but it is immediately followed by a reverse run	The selected level of obstacle detection sensitivity could be too high for the type of gate. Check to see whether there are any obstacles; if necessary select a lower level of sensitivity.
The manoeuvre is carried out but the flashing light does not work	Make sure that there is voltage on the flashing light’s FLASH terminal during the manoeuvre (being intermittent, the voltage value is not important: approximately 10-30Vdc); if there is voltage, the problem is due to the lamp; in this case replace the lamp with one of the same characteristics; if there is no voltage, there may have been an overload on the FLASH output. Check that the cable has not short-circuited.
The manoeuvre is carried out but the Open Gate Indicator does not work	Check the type of function programmed for the Gate Open indicator output (L4 on table 9). When the indicator should be lit, check that there is voltage on the Open Gate Indicator terminal (approx. 24 Vdc); if voltage is present the problem is caused by the light, which will have to be replaced with one with the same characteristics. If there is no voltage, there may have been an overload on the open gate indicator output. Check that the cable has not short-circuited.

### 7.6.1) Malfunctions archive

RUN enables the user to view the possible malfunctions that have occurred in the last 8 manoeuvres; for example, the interruption of a manoeuvre due to a photocell or sensitive edge cutting in. To verify the malfunctions list, proceed as in table 20.

**Table 20: malfunctions archive**

	Example
1. Press and hold <b>[Set]</b> (approx. 3 s)	3s
2. Release <b>[Set]</b> when led L1 starts flashing	L1 SET
3. Press key <b>[▲]</b> or <b>[▼]</b> to move the flashing LED onto the input LED L8 representing the “malfunctions list” parameter	L8
4. Press and hold <b>[Set]</b> during steps 5 and 6	SET
5. Wait for about 3s after which the LEDs corresponding to the manoeuvres in which the defect occurred will light. The L1 LED indicates the result of the last manoeuvre and L8 indicates the result of the 8th manoeuvre. If the LED is on, this means that a defect occurred during that manoeuvre; if the LED is off, this means that no defect occurred during that manoeuvre.	3s
6. Press keys <b>[▲]</b> and <b>[▼]</b> to select the required manoeuvre: The corresponding LED flashes the same number of times as those made by the flashing light after a defect (see table 21).	L8
7. Release the key <b>[Set]</b> .	SET

## 7.7) Diagnostics and signals

A few devices issue special signals that enable identification of operating status or possible malfunctions.

### 7.7.1) Flashing light signalling

During the manoeuvre the flashing light FLASH flashes once every second. When something is wrong the flashes are more frequent; the light flashes twice with a pause of a second between flashes.

Table 21: FLASH flashing light signalling		
Quick flashes	Cause	ACTION
1 flash 1 second pause 1 flash	Error on BlueBUS	At the start of the manoeuvre, the devices connected to BLUEBUS do not correspond to those recognized during the self-learning phase. One or more devices may be faulty; check and, if necessary, replace them; in case of modifications repeat the self-learning process (7.3.4 Self-learning Other Devices).
2 flashes 1 second pause 2 flashes	Activation of a photocell	At the start of the manoeuvre, one or more photocells do not enable it; check to see if there are any obstacles. This is normal when there is an obstacle impeding the movement.
3 flashes 1 second pause 3 flashes	Activation of "obstacle detection"	During the movement, the gate experienced excessive friction; identify the cause.
4 flashes 1 second pause 4 flashes	Activation of STOP input	At the start of the manoeuvre or during the movement, the STOP input was activated; identify the cause
5 flashes 1 second pause 5 flashes	Error in parameters in electronic control unit	Wait at least 30 seconds, then try giving a command. if the condition persists it means there is a malfunction and the electronic board has to be replaced
6 flashes 1 second pause 6 flashes	Maximum limit of manoeuvres per hour exceeded	Wait for a few minutes until the manoeuvre limiting device falls to below the maximum limit
7 flashes 1 second pause 7 flashes	Error in internal electrical circuits	Disconnect all the power circuits for a few seconds and then try to give the command again. if the condition persists it means there is a serious malfunction and the electronic board has to be replaced
8 flashes 1 second pause 8 flashes	A command is already present that disables execution of other commands	Check the type of command that is always present; for example, it could be a command from a timer on the "open" input.

### 7.7.2) Signals on the control unit

On the RUN control unit there is a set of LED's each of which can give special indications both during normal operation and in case of malfunctions.

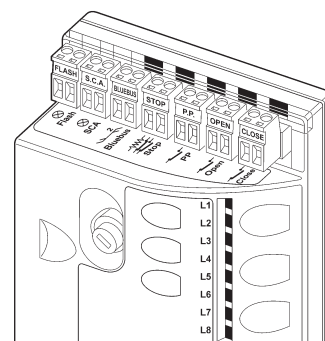

29

Table 22: LED's on the control unit's terminals		
BLUEBUS LED	Cause	ACTION
Off	Fault	Make sure there is power supply; check to see if the fuses are blown; if necessary, identify the reason for the failure and then replace the fuses with others of the same characteristics
On	Serious fault	There is a serious malfunction; try switching off the control unit for a few seconds; if the condition persists it means there is a malfunction and the electronic board has to be replaced
One flash every second	All OK	Normal operation of control unit
2 quick flashes	Input status variation occurred	This is normal when there is a change in one of the inputs: STEP-BY-STEP, STOP, OPEN, CLOSE, triggering of photocells or the radio transmitter is used
Series of flashes separated by a one second pause	Various	Same signal as on flashing light. See table 21
STOP led	Cause	ACTION
Off	Activation of STOP input	Check the devices connected to the STOP input
On	All OK	STOP input active
S.S. Led	Cause	ACTION
Off	All OK	S.S. input not active
On	Activation of S.S. input	Normal if the device connected to the S.S. input is effectively active
OPEN Led	Cause	ACTION
Off	All OK	OPEN input not active
On	Activation of OPEN input	Normal if the device connected to the OPEN input is effectively active
CLOSE Led	Cause	ACTION
Off	All OK	Close input not active
On	Activation of CLOSE input	Normal if the device connected to the CLOSE input is effectively active



**Table 23: leds on control unit keys**

Led 1	Description
Off	During normal operation indicates "Automatic closing" not active
On	During normal operation indicates "Automatic closing" active
Flashing	<ul style="list-style-type: none"> <li>Function programming in progress</li> <li>If Flashing with L2 indicates need for device self-learning phase (see paragraph "4.3 Device self-learning").</li> </ul>
Led L2	Description
Off	During normal operation indicates "Reclose after Photo" not active
On	During normal operation indicates "Reclose after Photo" active
Flashing	<ul style="list-style-type: none"> <li>Function programming in progress.</li> <li>If flashing with L1, indicates need for device self-learning phase (see paragraph "4.3 Device self-learning")</li> </ul>
Led L3	Description
Off	During normal operation indicates "Always close" not active.
On	During normal operation indicates "Always close" active.
Flashing	<ul style="list-style-type: none"> <li>Function programming in progress.</li> <li>If flashing with L4 indicates need for device self-learning phase (see paragraph "4.3 Device self-learning")</li> </ul>
Led L4	Description
Off	During normal operation the device indicates "Stand-by" not active.
On	During normal operation the device indicates "Stand-by" active.
Flashing	<ul style="list-style-type: none"> <li>Function programming in progress.</li> <li>If flashing with L3 indicates need for leaf length self-learning phase (refer to Paragraph "4.4 Leaf length Self-learning").</li> </ul>
Led L5	Description
Off	During normal operation indicates "Thrust" not active.
On	During normal operation indicates "Thrust" active.
Lampeggia	Function programming in progress.
Led L6	Description
Off	During normal operation indicates "Pre-flash" not active.
On	During normal operation indicates "Pre-flash" active.
Flashing	Function programming in progress
Led L7	Description
Off	During normal operation indicates that the CLOSE input activates a close manoeuvre
On	During normal operation indicates that the CLOSE input activates a partial opening manoeuvre.
Flashing	Function programming in progress
Led L8	Description
Off	During normal operation indicates that RUN is configured as Master
On	During normal operation indicates that RUN is configured as Slave
Flashing	Function programming in progress

## 7.8) Accessories

The following optional accessories are available for RUN:

- SMXI or SMXIS: Radio receiver at 433.92MHz with digital Rolling Code encoding.
- ONEXI: Radio receiver at 433.92MHz with digital Rolling Code encoding; equipped with Modo III to send 15 types of command to control unit

- OperaView; Remote programming unit.

Consult the Nice S.p.a. product catalogue for the complete and updated list of accessories.

### 7.8.1) Remote programming unit

More specifically, connector BusT4 (see figure 30) enables connection of the remote programming unit Oview which enables complete and rapid management of installation, maintenance and troubleshooting of any malfunctions.

To access the connector, remove the membrane as shown in figure 31. The remote programming unit can be placed at a distance from the control unit, with up to 100m of cable; it can be connected simultaneously to up to 16 and can remain connected during normal operation of RUN; in this case a specific "user" menu enables delivery of commands to the control unit.

If a OXI (o OXIT) type radio receiver is inserted in the control unit, the remote programming unit enables access to the parameters of the memorised transmitters.

These functions require a 4-core connection cable (BusT4).

The RUN control unit firmware can also be updated. Further information is available in the Oview programmer instruction manual.

**IMPORTANT** – For further details on all functions of the NiceOpera system and interdependency of the various devices in the system, refer to the general manual "NiceOpera System Book", also available on the Internet site [www.niceforyou.com](http://www.niceforyou.com).

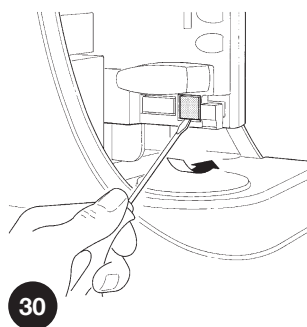

30

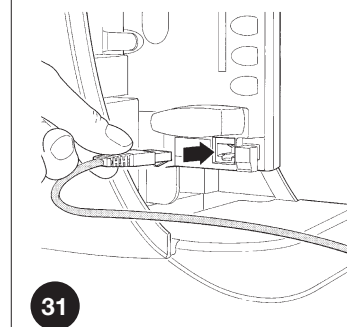

31

## 8) Technical characteristics

With the aim of improving products, Nice S.p.a reserves the right to modify technical characteristics at any time without notice, while maintaining the same functionalities and intended use.

All technical characteristics stated refer to an ambient temperature of 20°C (±5°C).

RUN Technical characteristics		
Model type	RUN 1800 - RUN 1800P - RUN 1800/V1	RUN 2500 - RUN 2500P
Type	Electromechanical gearmotor for automatic movement of sliding gates for industrial use complete with electronic control unit.	
Pinion	Number of teeth 18; Module 4 *	
Maximum torque on start-up [corresponds to ability of generating the force required to move the leaf]	40Nm (1110N)	50Nm (1390N)
Nominal torque [corresponds to the ability of generating the force to maintain the leaf in movement]	20Nm (560N)	30Nm (830N)
Speed (no-load)	10m/min (12m/min version /V1)	
Speed (at nominal torque)	8,5m/min (8.9m/min version /V1)	
Maximum frequency of operating cycles (at nominal torque)	11 cycles/hour (264 cycles/day), for a gate of 15m (equal to a cycle of 63%), (the control unit limits cycles to the maximum number specified in tables 2 and 3)**	15 cycles/hour (365 cycles/day), for a gate of 15m (equal to a cycle of 63%), (the control unit limits cycles to the maximum number specified in tables 2 and 3)**
Maximum time of continuous operation (at nominal torque)	40 minutes (the control unit limits continuous operation to the maximum limits as specified in tables 2 and 3)***	60 minutes (the control unit limits continuous operation to the maximum limits as specified in tables 2 and 3)***
Operating limits	In general RUN is designed for the automation of gates with the weights and lengths as specified in tables 2, 3 and 4	
Durability	Estimated between 150.000 cycles and 450.000 cycles according to conditions specified in table 4	
Power supply RUN 1800 - 2500	230Vac (+10% -15%) 50 Hz	
Power supply RUN 1800/V1-2500/V1	120Vac (+10% -15%) 60 Hz	
Maximum power absorption on start-up [corresponding to Amps]	700 W [3 A] [5 A version /V1]	870 W [3.8 A]
Power at nominal torque [corresponding to Amps]	400 W [1.8 A] [3 A version /V1]	600 W [2.7 A]
Insulation class	1 (safety earthing required)	
Flashing light output	For 2 Flashing lights LUCYB (lamp 12V, 21W)	
Gate open indicator output	For 1 24V lamp of maximum 4W (output voltage may vary between -30 and +50% and can also control small relays)	
BLUEBUS output	One output with maximum load of 15 BlueBus units	
STOP input	For normally closed contacts , normally open contacts or with constant 8,2kΩ. resistance; in self-learning (a variation with respect to memorised value generates the STOP command)	
Step-by-step input	For normally open contacts (contact closure generates S.S. command)	
OPEN input	For normally open contacts (contact closure generates OPEN command)	
CLOSE input	For normally open contacts (contact closure generates CLOSE command)	
Radio connector	SM connector for receivers SMXI; SMXIS or ONEXI	
Radio ANTENNA input	Input ANTENNA Radio 52Ω for cable type RG58 or similar	
Programmable functions	8 ON-OFF type functions and 8 settable functions (see tables 7 and 9)	
Functions in self-learning mode	Self-learning of devices connected to BlueBus output. Self-learning of "STOP" device type (contact NO, NC or 8,2kΩ resistance) Self-learning of gate length and calculation of deceleration and partial opening points.	
Operating temperature	-20°C ÷ 50°C	
Use in particularly acidic, saline or potentially explosive atmospheres	No	
Protection rating	IP 44	
Dimensions and weight	400 x 255 h 390; 24.5 kg	

\* Optional 12-tooth 6 module pinion available

\*\* At 50°C and with a gate of 15 metres, the maximum operating frequency is 7 cycles/hour (equal to a cycle of 40%).

\*\*\* At 50°C the maximum continuous operation time is 10 minutes.

- **Before using your automation system for the first time**, ask the installer to explain the origin of residual risks; take a few minutes and read the users **instructions manual given you by the installer**. Retain the manual for future use and deliver it to any subsequent owner of the automation system.
- **Your automation system is a machine that will faithfully execute your commands**; unreasonable or improper use may generate dangers: do not operate the system if there are people, animals or objects within its range of operation.
- **Children**: automation systems are designed to guarantee high levels of safety and security. They are equipped with detection devices that prevent movement if people or objects are in the way, guaranteeing safe and reliable activation. However, children should not be allowed to play in the vicinity of automated systems; to prevent any accidental activations, keep all remote controls away from children: **they are not toys!**
- **Malfunctions**: If you notice that your automation is not functioning properly, disconnect the power supply to the system and operate the manual release device. Do not attempt to make any repairs; call the installation technician and in the meantime, operate the system like a non-automatic door after releasing the gearmotor as described below.
- **Maintenance**: Like any machine, your automation needs regular periodic maintenance to ensure its long life and total safety. Arrange a periodic maintenance schedule with your installation technician. Nice recommends that maintenance checks be carried out every six months for normal domestic use, but this interval may vary depending on the intensity of use. Only qualified personnel are authorised to carry out checks, maintenance operations and repairs.
- Do not modify the system or its programming and adjustment parameters in any way, even if you feel capable of doing it: your installation technician is responsible for the system.
- The final test, the periodic maintenance operations and any repairs must be documented by the person who has performed them; these documents must remain under the custody of the owner of the system.

**The only recommended** maintenance operations that the user can perform periodically concern the cleaning of the photocell glasses and the removal of **leaves and debris that may impede the automation**. To prevent anyone from activating the gate release the automation system (as described below). Use a slightly damp cloth to clean.



**Manual movement and release:** before carrying out this operation please note that release can only occur when the leaf is stopped.

**1** Slide the lock cover disc.

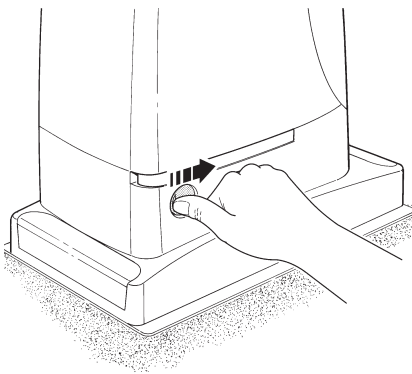

**2** Insert and turn the key clockwise.

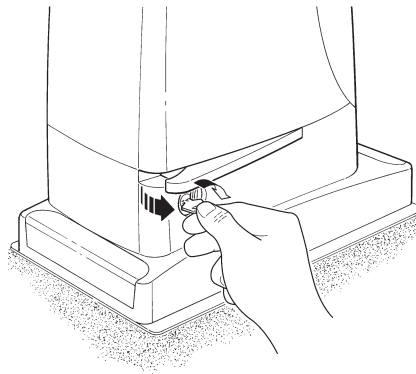

**3** Pull the release handle.

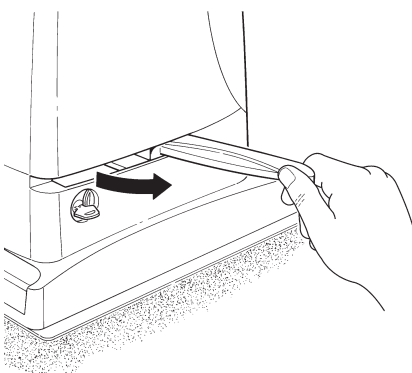

**4** Move the leaf manually.

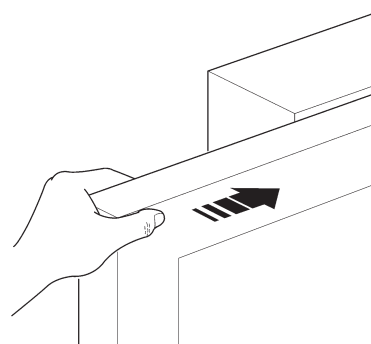

**To lock:** carry out the same procedures backwards.

**Control with safety devices out of order:** If the safety devices are malfunctioning, it is still possible to control the gate.

- Operate the gate control device (remote control or key-operated selector switch, etc.). If the safety devices enable the operation, the gate will open and close normally, otherwise the flashing light flashes a few times but the manoeuvre does not start (the number of flashes depends on the reason why the manoeuvre is not enabled).
- In this case, **actuate the control** again within 3 seconds and keep it actuated.
- After approximately 2s the gate will start moving in the "man present" mode, i.e. so long as the control is maintained the gate will keep moving; as soon as the control is released the gate will stop.

**⚠ If the safety devices are out of order the automation must be repaired as soon as possible.**

**Replacing the Remote Control Battery:** if your radio control, after a period of time, seems not to work as well, or not to work at all, it may simply be that the battery is exhausted (depending on the type of use, it may last from several months up to one year and more). In this case you will see that the light confirming the transmission is weak, or does not come on, or comes on only briefly. Before calling the installation technician try exchanging the battery with one from another operating transmitter:

if the problem is caused by a low battery, just replace it with another of the same type. The batteries contain polluting substances: do not dispose of them together with other waste but use the methods established by local regulations.

## CE declaration of conformity and declaration of incorporation of partly completed machinery

Declaration in accordance with the following Directives: 2004/108/EC (EMC); 2006/42/EC (MD) Annex II, Part B

**Note** - The content of this declaration corresponds to that specified in the official document deposited at the Nice S.p.A. headquarters and, in particular, to the latest revised edition available prior to the publishing of this manual. The text herein has been re-edited for editorial purposes. A copy of the original declaration can be requested from Nice S.p.A. (TV) - Italy

**Number:** 238/RUN

**Revision:** 5

**Language:** EN

**Manufacturer's Name:**

Nice S.p.A.

**Address:**

Via Pezza Alta 13, 31046 Rustignè di Oderzo (TV) Italy

**Person authorised to compile  
the technical documentation:**

Nice S.p.A.

**Type of product:**

Electromechanical gearmotor with incorporated control unit

**Models:**

RUN1800, RUN2500, RUN1800P, RUN2500P

**Accessories:**

Radio receiver models SMXI, SMXIS and ONEXI

The undersigned, Mauro Sordini, as Chief Executive Officer, hereby declares under his own responsibility that the products identified above comply with the provisions of the following directives:

- DIRECTIVE 2004/108/EC OF THE EUROPEAN PARLIAMENT AND COUNCIL of 15 December 2004 on the approximation of the laws of Member States relating to electromagnetic compatibility and repealing Directive 89/336/EEC, in accordance with the following harmonised standards: EN 61000-6-2:2005, EN 61000-6-3:2007 + A1:2011

In addition, the product conforms to the following directive in accordance with the provisions applicable to partly completed machinery:

Directive 2006/42/EC OF THE EUROPEAN PARLIAMENT AND COUNCIL of 17 May 2006 regarding machines and amending Directive 95/16/EC (consolidated text)

- It is hereby declared that the pertinent technical documentation has been drafted in accordance with Annex VII B of Directive 2006/42/EC and that the following essential requirements have been met: 1.1- 1.1.2- 1.1.3- 1.2.1-1.2.6- 1.5.1-1.5.2- 1.5.5- 1.5.6- 1.5.7- 1.5.8- 1.5.10- 1.5.11
- The manufacturer agrees to provide to the national authorities pertinent information on the partly completed machinery, in response to a motivated request, without prejudice to its intellectual property rights.
- If the partly completed machinery is operated in a European country with an official language other than the language used in this declaration, the importer must include a translation with this declaration.
- The partly completed machinery must not be operated until the final machine in which it is to be incorporated is declared to conform to the provisions of Directive 2006/42/EC, if applicable.

The product also complies with the following standards:

EN 60335-1:2012 EN 60335-2-103:2003 + A11:2009

The parts of the product which are subject to the following standards comply with them:

EN 13241-1:2003+A1:2011, EN 12445:2002, EN 12453:2002, EN 12978:2003+A1:2009

Oderzo, 01 July 2014

**Mr. Mauro Sordini**  
(Chief Executive Officer)

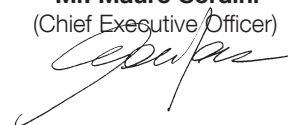







**Nice SpA**  
Oderzo TV Italia  
info@niceforyou.com

[www.niceforyou.com](http://www.niceforyou.com)