

Industrial

CE

D-Pro Automatic

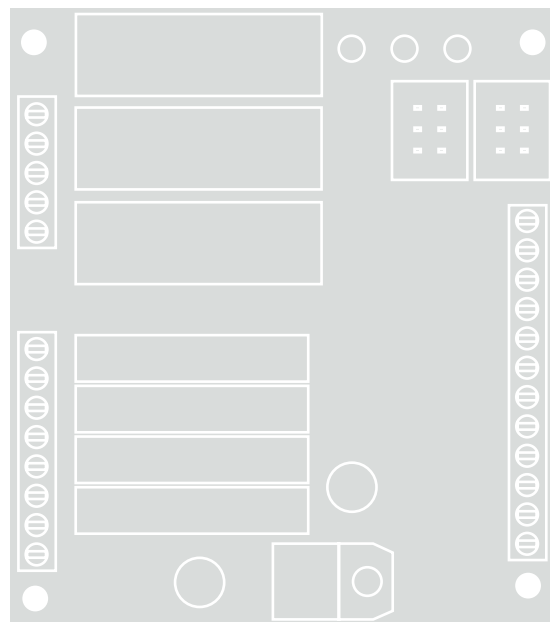

Input and Relay Module K30

EN - Instructions and warnings for installation and use

Nice

Original operation manual in German

This operation manual covers the devices of the M01 series.

TABLE OF CONTENTS

	Page
GENERAL SAFETY INSTRUCTIONS	1
KNOWLEDGE OF THE SYSTEM AND PREPARATIONS FOR INSTALLATION	1
INSTALLATION OF THE INPUT AND RELAY MODULE K30 - SETTING	2
DECLARATION OF CONFORMITY	3

GENERAL SAFETY INSTRUCTIONS

The planning and production of the parts making up the Input and Relay Module K30, and the information in this operation manual, comply with the applicable safety regulations. Incorrect installation can result in serious injuries to the persons performing the installation or using the system. For this reason, it is very important to observe all the instructions in this manual during installation.

Do not continue with the commissioning if you are in any doubt, and request help from the customer service at Nice, if necessary.

WORK SAFELY!

ATTENTION! – For the safety of persons it is important to observe these instructions.

ATTENTION! – You must keep any instructions that are relevant to safety available.

Always observe the following instructions:

- **Only implement the electrical connections specified in this manual. An incorrect implementation of the connections could cause serious damage to the system.**
- **If the cabling is used outside, it must be protected completely by a conduit.**

Due to the risks that can occur during the installation and operation of the system, the drive system must be installed in compliance with the following instructions:

- Only make the changes to the door control that are described in this manual. Any other changes can lead to malfunctions. The manufacturer accepts no liability for damage caused by arbitrary changes to the control unit.
- Do not install the control units near heat sources or open flames. This can cause malfunctions, fire and dangers.
- The control unit should not be immersed in water or other liquids during installation. Prevent liquids from penetrating the system during installation.
- The packaging material of the door control must be disposed of in strict observance of local regulations.

ATTENTION! – Store this manual carefully to facilitate future disposal and maintenance work on the equipment.

KNOWLEDGE OF THE SYSTEM AND PREPARATION FOR INSTALLATION

Description and use

The Input and Relay Module K30 is an extension for the D-PRO Automatic Control Unit.

With its various inputs and potential-free outputs, the module offers additional application options for the door control to which the Input and Relay Module K30 is connected.

Any other use is improper use! The manufacturer accepts no liability for damage caused by improper use of the various system devices that goes beyond the use described in this manual.

The company erecting the system is responsible for the entire system starting with the installation. This party must ensure that the relevant standards and guidelines (e.g. EN 13241-1) are observed. The company erecting the system must ensure that the EMC directives, low-voltage directives, machinery directives and building products guideline are observed.

This party is also responsible for the creation of technical documentation for the entire system, which must also be supplied with the system.

The national and local standards and regulations for installation and the accident prevention regulations of the professional associations must be observed.

When working on the door control system, it must always be switched voltage-free.

Checks before installation

Please read through this installation and operation manual carefully before beginning with the installation of the control unit.

We will be released from warranty and product liability if, without our prior written permission, unauthorised construction changes are made or incorrect installations are initiated or performed that contravene our specified assembly guidelines.

The company erecting the system must ensure that the EMC directives, low-voltage directives, machinery directives and building products guideline are observed.

CAUTION! - The Control Unit may not be used in an area at risk of explosion.

Installation of the Input and Relay Module K30 - SETTING

Installation of the Input and Relay Module K30

Insert the plug of the module connection cable in the J2 slot on the main board of the D-PRO Automatic. Insert the module board onto the four black guide bolts on the main board. Fasten the module by bolting the four supplied spacers onto the guide bolts.

Relay functions

- Relay 1 --> external traffic lights (red / green)
- Relay 2 --> internal traffic lights (red / green)
- Relay 3 --> traffic lights On/Off

- Relay 4 --> potential-free 1 up (display of upper final position)
- Relay 5 --> potential-free 2 down (display of lower final position)
- Relay 6 --> photoelectric barrier test 1
- Relay 7 --> photoelectric barrier test 2

The traffic light output (relay1, relay 2 and relay3) is deactivated by default. The traffic light output can be activated by parameter P80 of the D-Pro Automatic.

Settings on the cover board with the parameters P120 to P133!

Testing of the photoelectric barriers - see Fig. 2

Only photoelectric barriers with a transmitter/receiver compliant with the standards can be used as an anti-entrapment photoelectric barrier.

The transmitter or, if two anti-entrapment photoelectric barriers (internal and external) are used, both transmitters are to be connected to the terminals O10 and O11 or O12 and O13 on the Input and Relay Module K30.

The receiver contact then directly intervenes in the safety circuit (during the upward movement). The connection is made on the main board of the D-PRO Automatic Control Unit at terminal X6/J33.

ATTENTION: Operation of the anti-entrapment safety devices is automatically tested before each ascent. The parameters P132 and P133 must therefore be set to 1.

Automatic closing ON/OFF

If a switch is connected to the terminals I5 and I6, it can be used to enable or disable the "automatic closing" function.

To switch off automatic closing, the contact must be opened.

External OPENING using buttons

If traffic lights for two-way traffic are connected to the Input and Relay Module K30, a button contact with zero potential (closing contact) must be connected to terminals I9 and I10 to activate the external green traffic light.

Partial opening with electronic limit switch

If the D-PRO Automatic control unit operates with an electronic limit switch (EES), a selector switch for activation of the partial opening must be connected to terminals I7 and I8.

Connection of a fire alarm system

The potential-free contact of a fire alarm system can be connected to the terminals I1 and I2. The functions that are then available can be set through parameter P125.

Function light barrier 2

The potential-free contact of a second function light barrier can be connected to the terminals I11 and I12.

ATTENTION: All inputs and outputs of the Input and Relay Module K30 can be assigned functions other than those stated here. The reprogramming is done through parameter entries on the cover board (see parameters P120 through P133 in the parameter list).

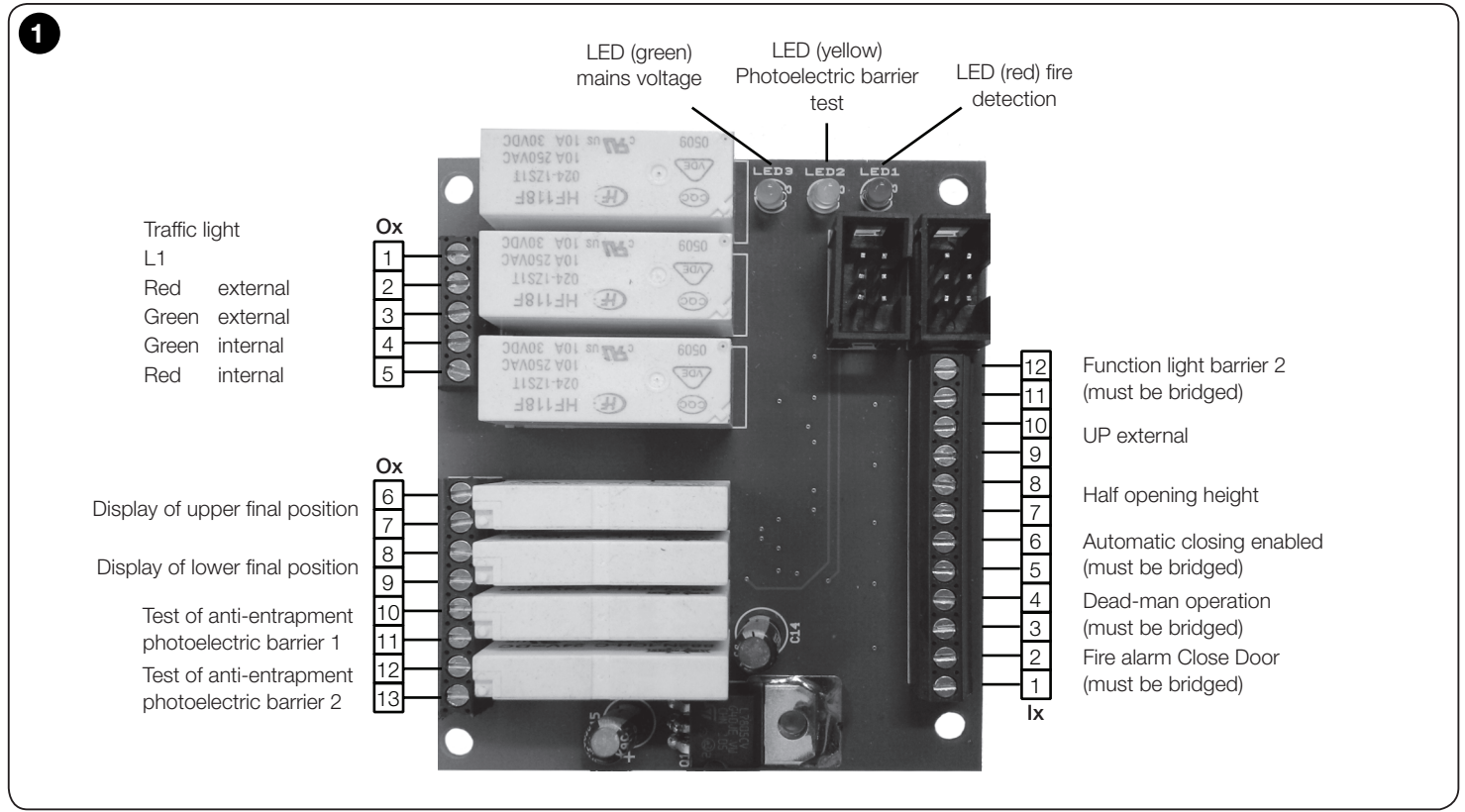

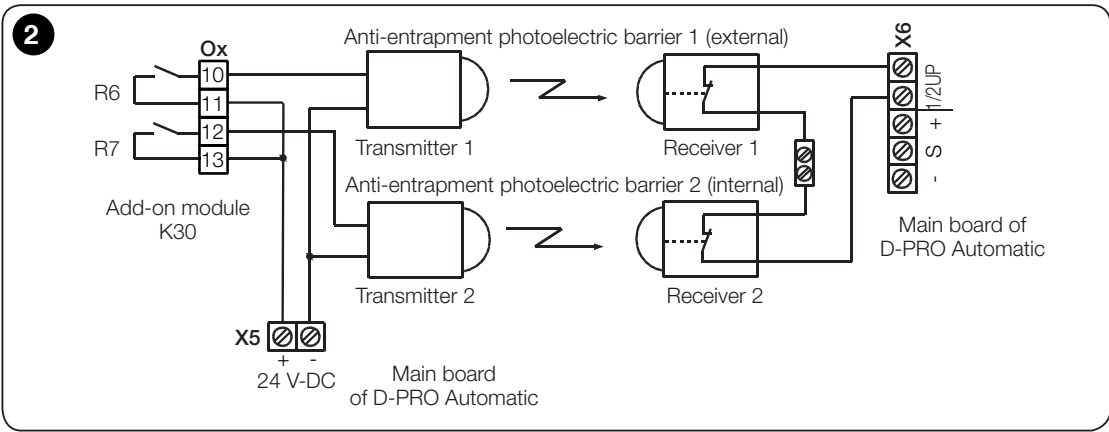

ATTENTION: If two photoelectric barriers are used as an anti-entrapment safeguard, the relay contacts (opening contacts) of the receivers must be switched in series and connected at terminal J33 on the main board of the D-PRO Automatic Door Control.

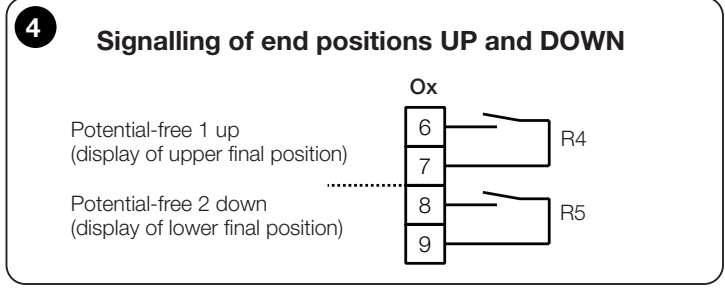
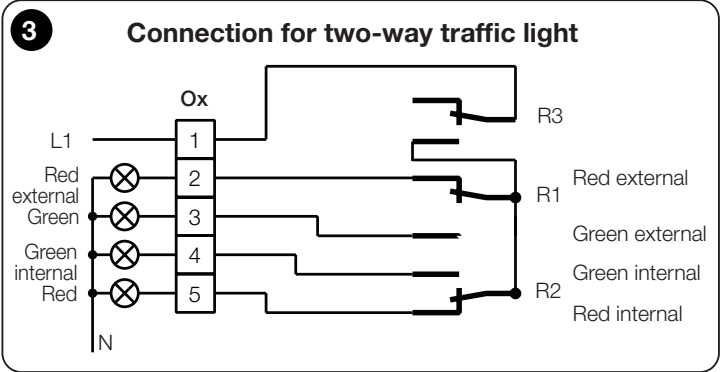

EU declaration of conformity and declaration of incorporation of “partly completed machinery”

Download the D-Pro Automatic “CE” declaration of conformity from the website www.niceforyou.com

NDA030

WO: S/N123456

INSTR.MANUAL

CODE: NDA030 23345



NDA030



Nice SpA
Oderzo TV Italia
info@niceforyou.com

www.niceforyou.com