

Attachment L
Drawings and Specifications

DEPARTMENT OF CORRECTIONS CENTRAL DETENTION FACILITY (DC JAIL)

1901 D STREET SE, WASHINGTON, DC 20003

MAINTENANCE SHOP HVAC & LAUNDRY ROOM ALTERATIONS - ADMINISTRATION MODULE

ARCHITECT/ENGINEER
C.C. JOHNSON & MALHOTRA, P.C.
1025 CONNECTICUT AVE, N.W., SUITE 1017
WASHINGTON, DC 20036
TEL: (202) 363-0465 FAX: (202) 363-0350

Project No: CR-104C
GOVERNMENT OF THE DISTRICT OF COLUMBIA
DEPARTMENT OF GENERAL SERVICES

MEP ENGINEERS (CBE)
JVP ENGINEERS, P.C.
5101 WISCONSIN AVENUE, N.W. SUITE 400
WASHINGTON, DC 20016-4140
TEL: (202) 362-3001 FAX: (202) 362-5541

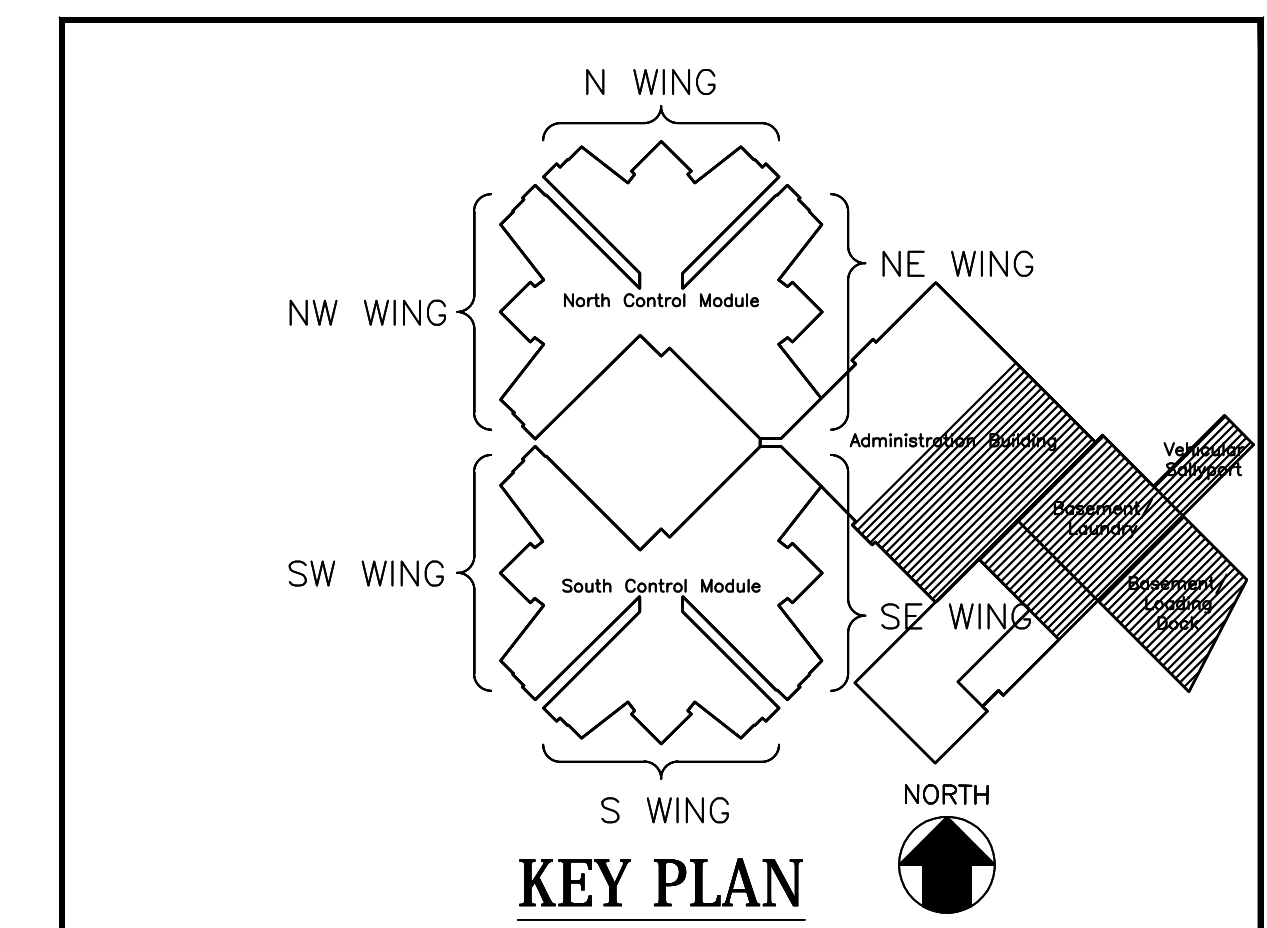
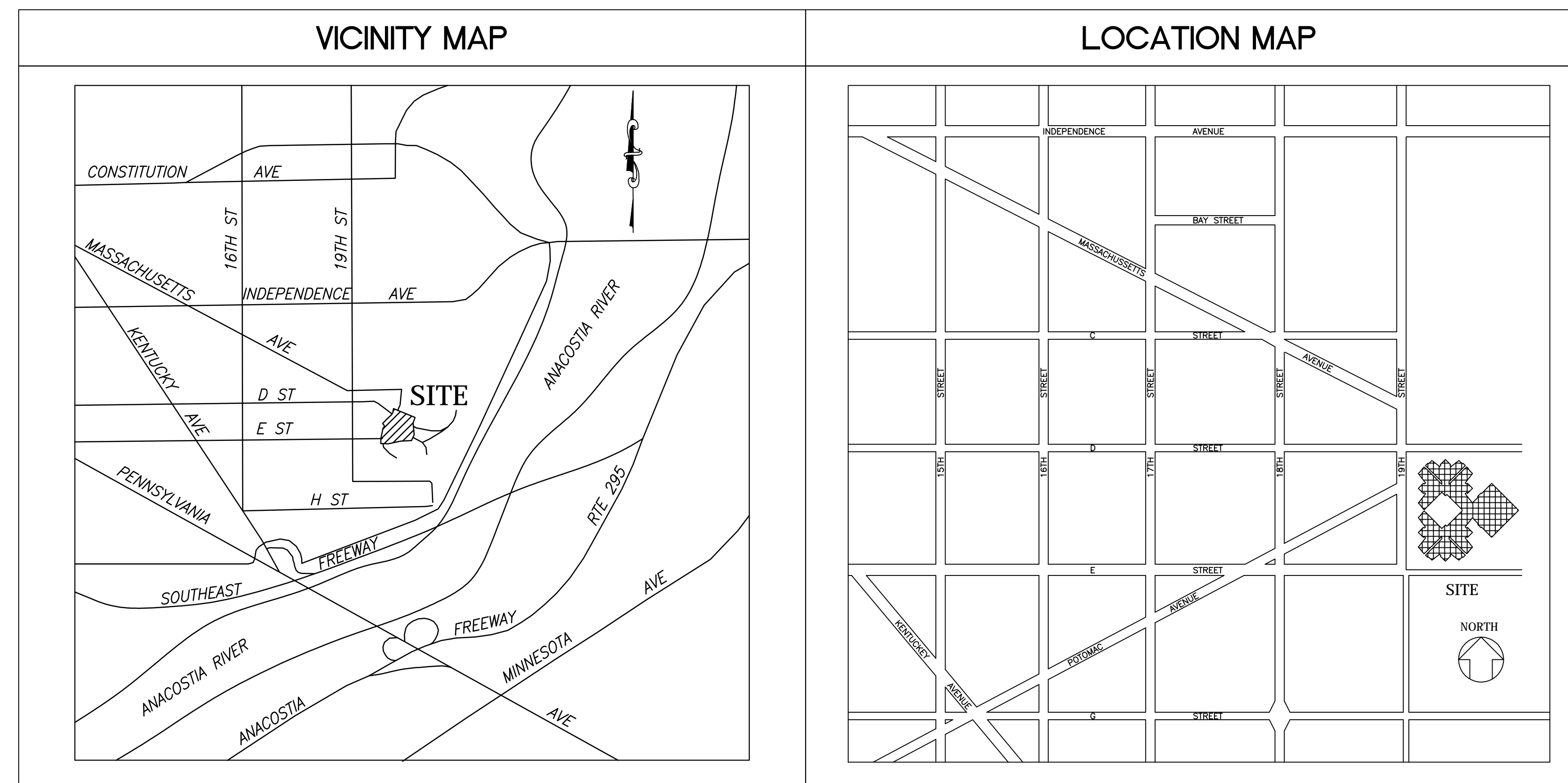

100% CONSTRUCTION DOCUMENTS

DESIGNED: CCJM					
DRAWN: CCJM					
CHECKED: CCJM					
	REVISION	DATE	DESCRIPTION	BY	APP.
PROJECT DRAWINGS					
CERTIFICATION	COVER SHEET			GENERAL	
I HEREBY CERTIFY THAT THESE DOCUMENTS WERE PREPARED OR APPROVED BY ME, AND THAT I AM A DULY LICENSED ARCHITECT / PROFESSIONAL ENGINEER UNDER THE LAWS OF THE DISTRICT OF COLUMBIA					
REGISTRATION NO.	CCJM C.C. Johnson & Malhotra, P.C.			DRAWING NO.	
EXP. DATE:	1025 Connecticut Ave, N.W., Suite 1017 Washington, DC 20036			G-000	
ARCHITECT/ENGINEER	GOVERNMENT OF THE DISTRICT OF COLUMBIA			BUILDING ID NO.: 299	
	DEPARTMENT OF GENERAL SERVICES			PROJECT NO.: CR-104C	
				DATE: APR 6, 2016	
				SHEET: 1 OF 16	

PROJECT INFORMATION

PROJECT
 DEPARTMENT OF CORRECTIONS
 CENTRAL DETENTION FACILITY (CDF)
 1901 D STREET SE - WASHINGTON, DC 20003

DEPARTMENT OF GENERAL SERVICES
 OF THE DISTRICT OF COLUMBIA

PROJECT NO.: CR-104C

PROJECT SUMMARY
 MAINTENANCE SHOP HVAC & LAUNDRY ROOM ALTERATIONS: PROVIDE A NEW IRONING MACHINE IN LAUNDRY ROOM AT THE BASEMENT LEVEL. REMOVAL AND ADDITION OF DOORS TO ALLOW FOR EQUIPMENT RIGGING. PROVIDE WIRE MESH AND INSULATED METAL PANELS AT THE LAUNDRY EQUIPMENT TO PROVIDE SECURE AREA. SELECTIVE HVAC ALTERATIONS TO IMPROVE SPACE OVERHEAT ISSUE IN THE LAUNDRY ROOM AND MAINTENANCE SHOP AREAS.

EXISTING BUILDING INFORMATION
 EXISTING NUMBER OF STORIES: 3 FLOORS ABOVE GROUND WITH BASEMENT (UNCHANGED)
 EXISTING BUILDING AREA: 266,475 NSF (UNCHANGED)
 OCCUPANCY TYPE: GROUP 1-3 INSTITUTIONAL RESTRAINED OCCUPANCY

CONSTRUCTION TYPE: 1A (UNCHANGED)
 BUILDING FIRE SUPPRESSION: MIX - APPROXIMATELY 22, 580 NSF SUPPRESSED
 FIRE ALARM SYSTEM: YES

ALTERATIONS (LEVEL 2):
 BASEMENT LEVEL = 30,350 GSF EXISTING AREA, 9,450 GSF EXTENT OF ALTERATION PORTION FULLY SUPPRESSED
 CONSTRUCTION TYPE: 1A (UNCHANGED)
 OCCUPANCY TYPE: GROUP F-1 (UNCHANGED)

- APPLICABLE CODES:**
 THE DISTRICT OF COLUMBIA CONSTRUCTION CODES (2013):
- BUILDING CODES:**
 - 2012 ICC INTERNATIONAL BUILDING CODE (IBC) & DCMR 12-A BUILDING CODE SUPPLEMENT OF 2013
 - 2012 ICC INTERNATIONAL EXISTING BUILDING CODE (IEBC) & DCMR 12-J EXISTING BUILDING CODE SUPPLEMENT OF 2013.
 - ELECTRICAL CODE:**
 - 2011 NFPA 70 NATIONAL ELECTRICAL CODE (NEC) & DCMR 12-C ELECTRICAL CODE SUPPLEMENT OF 2013.
 - MECHANICAL CODE:**
 - 2012 ICC INTERNATIONAL MECHANICAL CODE (IMC) & DCMR 12-E MECHANICAL CODE SUPPLEMENT OF 2013
 - PLUMBING CODE:**
 - 2012 ICC INTERNATIONAL PLUMBING CODE (IPC) & DCMR 12-F PLUMBING CODE SUPPLEMENT OF 2013
 - FIRE CODE:**
 - 2012 ICC INTERNATIONAL FIRE CODE (IFC) & DCMR 12-H FIRE CODE SUPPLEMENT OF 2013
 - ENERGY CONSERVATION CODE:**
 - 2012 ICC INTERNATIONAL ENERGY CONSERVATION CODE (IECC) & DCMR 12-I ENERGY CONSERVATION CODE SUPPLEMENT OF 2013
 - FUEL GAS CODE:**
 - 2012 ICC INTERNATIONAL FUEL GAS CODE (IFGC) & DCMR 12-D FUEL GAS CODE SUPPLEMENT OF 2013
 - ACCESSIBILITY CODE:**
 - 2012 ICC INTERNATIONAL BUILDING CODE (IBC) / ICC A117.1-2009 & DCMR 12-A BUILDING CODE SUPPLEMENT OF 2013

GENERAL NOTES

- CONTRACTOR SHALL ADEQUATELY PROTECT GOVERNMENT WORK FORCE AND OCCUPANTS FROM CONSTRUCTION AND/OR DEMOLITION OPERATIONS INCLUDING FUMES, VAPORS, DUST, NOISE, ETC. ANY FUEL FIRED EQUIPMENT SHALL HAVE THE EXHAUST PIPED DIRECTLY TO THE OUTSIDE OF THE BUILDING OR BE PROVIDED WITH EXHAUST SCRUBBERS. THE CONTRACTOR SHALL ENSURE ALL FLAMMABLE LIQUIDS AT THE WORK SITE ARE PROPERLY STORED, DISPENSED AND LABELED AND SHALL NOT LEAVE ANY FLAMMABLE HAZARDOUS MATERIAL BEHIND AT THE COMPLETION OF THE WORK DAY FOR ANY REASON. COMPLIANCE WITH OSHA DOES NOT RELIEVE THE CONTRACTOR FROM MEETING ALL OTHER SPECIFICATION REQUIREMENTS.
- THE CLOSING OF EMERGENCY EXITS WILL NOT BE PERMITTED. PROTECTIVE TUNNELS, ENCLOSURES AND OR RAMPS SHALL BE PROVIDED AS NECESSARY TO MAINTAIN THE REQUIRED MEANS OF EGRESS FROM ADJACENT OCCUPIED AREAS. ALL PROTECTIVE MEASURES AND CONSTRUCTION SHALL BE APPROVED BY THE CONTRACTING OFFICER'S TECHNICAL REPRESENTATIVE (COTR) PRIOR TO INSTALLATION. OPERATIONS THAT REQUIRE EXITS TO BE CLOSED MUST BE DONE AT TIMES APPROVED BY CONTRACTING OFFICER. COORDINATE WITH THE COTR ALL IMPACTS OF THE WORK TO EXISTING MEANS OF EGRESS FROM ADJACENT OCCUPIED AREAS. PROVIDE TEMPORARY PROTECTION, TEMPORARY WALLS AND DOORS TO SEPARATE CONSTRUCTION ACTIVITIES FROM PUBLIC SECURED AREAS.
- IT IS THE RESPONSIBILITY OF THE CONTRACTOR TO PROVIDE ALL FIRE EXTINGUISHERS NEEDED FOR THE PROTECTION OF THE JOB. EXTINGUISHERS SHALL BE OF THE PROPER SIZE AND TYPE.
- CONTRACTOR MUST SUPPLY ALL HOSES, CONNECTORS, ADAPTERS, HYDRANT WRENCHES, ETC. THAT ARE NEEDED. PROVISION OF UTILITIES SHALL BE AS DIRECTED BY THE COTR. CONTRACTOR MUST REQUEST PERMISSION FROM THE FIRE DEPARTMENT TO USE ANY FIRE HYDRANT. CONTRACTOR MUST USE ONLY SUITABLE WRENCHES AND BE AWARE OF THE PROPER OPERATION OF A FIRE HYDRANT.
- IF THERE IS A QUESTION ABOUT HAZARDOUS MATERIALS/ASBESTOS CONTAINING MATERIAL ENCOUNTERED DURING THE COURSE OF THE WORK THAT IS NOT IDENTIFIED IN THESE DOCUMENTS, THE CONTRACTOR WILL STOP WORK IMMEDIATELY AND CONTACT THE COTR FOR A DETERMINATION OF WHETHER OR NOT THE MATERIAL IS HAZARDOUS.
- ALL FIRES MUST BE REPORTED TO THE FIRE DEPARTMENT IMMEDIATELY ON 911 OR BY THE NEAREST FIRE ALARM PULL STATION.
- ALL DUMPSTERS MUST BE AT LEAST 13 FEET FROM BUILDINGS IN SECURED LOCATION APPROVED BY COTR. VERIFY ALLOWABLE LOCATIONS OF DUMPSTERS WITH COTR PRIOR TO PLACEMENT. DO NOT STORE REFUSE OR SALVAGED ITEMS, OR DEMOLITION EQUIPMENT IN SECURE AREAS. VERIFY APPROVED TEMPORARY STORAGE LOCATIONS WITH COTR AND DOC.
- CONTRACTOR SHALL OBTAIN AND PAY FOR ALL PERMITS, MATERIALS, LABOR, EQUIPMENT, TOOLS, CONSTRUCTION EQUIPMENT WAREHOUSING, TRANSPORTATION AND DELIVERY COSTS, HOISTING, REMOVAL OF TRASH AND DEBRIS, AND OTHER FACILITIES AND SERVICES NECESSARY FOR EXECUTING AND COMPLETING THE WORK.
- CONTRACTOR SHALL APPLY FOR, OBTAIN AND PAY FOR BUILDING PERMIT FEES. CONTRACTOR SHALL OBTAIN AND PAY FOR ALL TRADE PERMITS, INSPECTIONS AND APPROVALS BY LOCAL AUTHORITIES.
- SAFEGUARD ALL EXISTING GOVERNMENT PROPERTY TO REMAIN AND REPLACE OR REPAIR ANY PROPERTY DAMAGED BY THE WORK.
- CONTRACTOR SHALL COMPLY WITH ALL APPLICABLE CODES, REGULATIONS, LOCAL AUTHORITIES HAVING JURISDICTION AND THE LATEST EDITION OF U.S. DEPARTMENT OF LABOR STANDARDS C29CFR1926, THE OSHA CONSTRUCTION STANDARDS.
- CONTRACTOR SHALL OBTAIN AN EXCAVATION PERMIT FROM DOC PRIOR TO COMMENCEMENT OF ANY EXCAVATION WORK ON THE INSTALLATION OR ANY WORK THAT HAS THE POTENTIAL TO DAMAGE ANY UNDERGROUND UTILITIES, INCLUDING, BUT NOT LIMITED TO, INSTALLATION OF SIGNS, FENCE POSTS, UTILITY POLES, PLANTING TREES OR SHRUBS, ETC. WHEN THE PERMIT IS APPROVED, IT MUST BE KEPT ON SITE AT ALL TIMES.
- COORDINATE SCHEDULING, PROVISIONS FOR STORAGE AND INSTALLATION OF ITEMS FURNISHED BY THE GOVERNMENT AND BY OTHERS UNDER SEPARATE CONTRACTS.
- CONTRACTOR SHALL COMPLY WITH DOC REGULATIONS AND REQUIREMENTS, WHILE WORKING ON THE FACILITY PROPERTY. THE CONTRACTOR SHALL CONSIDERATE ALL HOT WORK (I.E. WORK THAT GENERATES SPARKS, USES AN OPEN FLAME OR HAS THE POTENTIAL TO GENERATE SPARKS OR CAUSE MATERIAL TO COMBUST). CONTACT APPROPRIATE LOCAL AUTHORITIES ON A 7 DAY A WEEK BASIS TO ISSUE PERMITS. NORMAL ADMINISTRATIVE HOURS ARE FROM 0900 THROUGH 1430. IF THE CONTRACTOR'S WORK SHALL COMPLY WITH REQUIREMENTS FOUND IN OSHA WHILE DOING HIGH WORK AND CONFINED SPACE ENTRIES, CONTRACTORS ARE RESPONSIBLE TO ISSUE THEIR OWN PERMIT FOR ENTRY INTO A PERMIT REQUIRED CONFINED SPACE, HOWEVER A COURTESY COPY OF THE PERMIT SHALL BE FILED WITH THE COTR WHO WILL NOTIFY THE APPROPRIATE AUTHORITIES, WHO WILL BE RESPONDING TO THE SCENE IN AN EMERGENCY. THE DOC WILL NOT SUPPLY A STAND-BY RESCUE TEAM FOR PERMIT REQUIRED ENTRIES FOR CONTRACTORS. THAT EXPENSE WILL BE BORN BY THE CONTRACTOR AND IS TO BE FACTORED INTO THE COST OF WORK.
- CONTRACTOR SHALL VERIFY ALL DIMENSIONS AND CONDITIONS AT THE JOB SITE BEFORE COMMENCEMENT OF WORK, AND SHALL REPORT ALL ERRORS, OMISSIONS OR DISCREPANCIES TO THE GOVERNMENT CONTRACTING OFFICER REPRESENTATIVE (COTR) IN WRITING PRIOR TO STARTING WORK. IN ALL CASES WHERE CONFLICTS MAY OCCUR, SUCH AS BETWEEN ITEMS INCLUDED IN THE SPECIFICATIONS AND NOTES ON THE DRAWING, THE GOVERNMENT COTR SHALL BE NOTIFIED AND WILL INTERPRET THE INTENT OF THE CONTRACT DOCUMENTS.
- DRAWING REFERENCES ARE FOR CONVENIENCE ONLY AND DO NOT LIMIT THE APPLICATION OF THE DRAWING OR DETAIL.
- ALL DIMENSIONS SHALL TAKE PRECEDENCE OVER SCALE. DIMENSIONS ARE GIVEN TO FACE OF CONCRETE, TO CENTERLINE OF COLUMNS, TO EXTERIOR FACE OF MASONRY AT EXTERIOR WALLS AND FACE OF INTERIOR STUD PARTITIONS UNLESS NOTED OTHERWISE.
- THE DRAWINGS MUST BE READ IN CONJUNCTION WITH THE TECHNICAL SPECIFICATIONS WHICH FORM A PART OF THE CONTRACT DOCUMENTS AND MAY CONTAIN ADDITIONAL REQUIREMENTS AND INFORMATION NOT SHOWN ON THE DRAWINGS. THE TECHNICAL SPECIFICATION MANUAL IS COMMON TO ALL PHASES INDICATED IN THESE DRAWINGS.
- THE ORIGINAL DRAWING SIZE IS 30"x42".
- CONTRACTOR IS RESPONSIBLE FOR ALL MEANS AND METHODS OF CONSTRUCTION THROUGHOUT THE PROJECT DURATION. PROVIDE ADEQUATE BRACING, SHORING, AND DISTRICT MEASURES NECESSARY TO PROTECT ALL WORK (BOTH NEW AND EXISTING) FROM DAMAGE, BREAKAGE, SETTLEMENT, OR COLLAPSE THAT MAY RESULT FROM THE CONSTRUCTION ACTIVITY. SHORE AND BRACE EXISTING AND NEW CONSTRUCTION AS REQUIRED PRIOR TO AND DURING CONSTRUCTION.
- IMPLEMENTING JOB SITE SAFETY AND CONSTRUCTION PROCEDURES ARE SOLELY THE RESPONSIBILITY OF THE CONTRACTOR.
- DURING CONSTRUCTION MAINTAIN ALL LIFE SAFETY SYSTEMS SUCH AS FIRE SUPPRESSION, FIRE ALARM DEVICES, HORN STROBES AND EGRESS ILLUMINATION. ALL EGRESS COMPONENTS SUCH AS EXITS, EXIT CORRIDORS, EXIT DISCHARGES SHALL REMAIN CLEAR AND FREE OF CONSTRUCTION DEBRIS, MATERIALS, AND EQUIPMENT.
- PRIOR TO CUTTING, DRILLING, CORING, OR CHIPPING EXISTING CONCRETE, CMU, OR PRE-CAST CONCRETE.
 - LOCATE EXISTING CONNECTION AND REINFORCEMENT USING NON-DESTRUCTIVE TESTING (GROUND PENETRATING RADAR OR X-RAY).
 - ADJUST OPENING LOCATIONS TO MINIMIZE NUMBER OF REINFORCEMENT BARS CUT.
 - SUBMIT SKETCHES AND PHOTOS OF PROPOSED LAYOUT FOR GOVERNMENT AND ARCHITECT/ENGINEER'S APPROVAL PRIOR TO CUTTING OPENING.
- CONTRACTOR WILL BE RESPONSIBLE TO RECYCLE MATERIALS ON THIS PROJECT IN ACCORDANCE WITH DC GOVERNMENT REGULATIONS. IN ADDITION, THE CONTRACTOR SHALL PROVIDE CONTAINERS FOR ALL LANDFILL WASTE AND SEPARATE CONTAINERS FOR EACH TYPE OF RECYCLED MATERIAL. THE CONTRACTOR MUST TAKE ALL RECYCLABLES COLLECTED OFF OF CENTRAL DETENTION FACILITY (CDF) TO A RECYCLER. GET DOCUMENTATION FROM THE RECYCLER (A RECEIPT WITH THE RECYCLER'S INFO AND THE DATE, WEIGHT AND TYPE OF SCRAP MATERIAL) AND PROVIDE A COPY OF EACH LOAD RECEIPT TO THE COTR.
- ALL INTERIOR WALLS ARE CONTINUOUS FROM THE FLOOR TO UNDERSIDE OF FLOOR SLAB. COORDINATE ALL PENETRATIONS, OPENINGS WITH CONTRACT DOCUMENT REQUIREMENTS. PRESERVE AND PROTECT ALL PENETRATIONS THROUGH FIRE-RATED CONSTRUCTION WITH APPROPRIATE FIRE DAMPERS, FIRE STOPPING MATERIALS OR FIRE DOORS AS REQUIRED BY LOCAL CODE OFFICIALS. MAINTAIN INTEGRITY OF ALL EXISTING AND NEW FIRE SEPARATIONS DURING CONSTRUCTION OF ALL WORK OF THIS CONTRACT.
- THE FACILITY WILL REMAIN IN OPERATION AND OPEN TO STAFF AND OCCUPANTS DURING CONSTRUCTION. PERFORM ALL WORK DURING APPROVED WORKING HOURS UNLESS OTHERWISE SPECIFICALLY APPROVED BY COTR. CONTRACTOR SHALL SCHEDULE AND PERFORM ALL WORK SO AS NOT TO UNREASONABLY DISTURB OCCUPANTS. RESTRICT ACTIVITIES PRODUCING HIGH NOISE LEVELS TO APPROVED TIMES AND SHALL BE COORDINATED WITH COTR.
- REFER TO DRAWING A-802 FOR DOOR, AND FRAME TYPE ELEVATIONS.
- REFER TO DRAWING A-802 FOR DOOR SCHEDULE.
- REFER TO DRAWING A-801 FOR WALL TYPES.

MATERIALS LEGEND

SECTION SYMBOLS	
EARTH	
GRAVEL/CRUSHED STONE	
CAST IN PLACE CONCRETE / PRE-CAST CONCRETE	
SAND/GROUT	
CONCRETE MASONRY UNITS	
STEEL	
ALUMINUM	
FINISHED WOOD	
PLYWOOD	
GLASS	
GYPSON BOARD	
BATT INSULATION	
RIGID INSULATION	
ACOUSTICAL TILE	
CARPET	
ROUGH CARPENTRY	
WOOD OR METAL SHIM OR SPACER	
ELEVATION SYMBOLS	
CONCRETE, PLASTER GYPSON BOARD, CUT STONE	
FINISHED WOOD	
GLASS	
CONCRETE MASONRY	
CERAMIC TILE	
SHEET METAL OR ALUMINUM	

SYMBOLS / ANNOTATIONS LEGEND

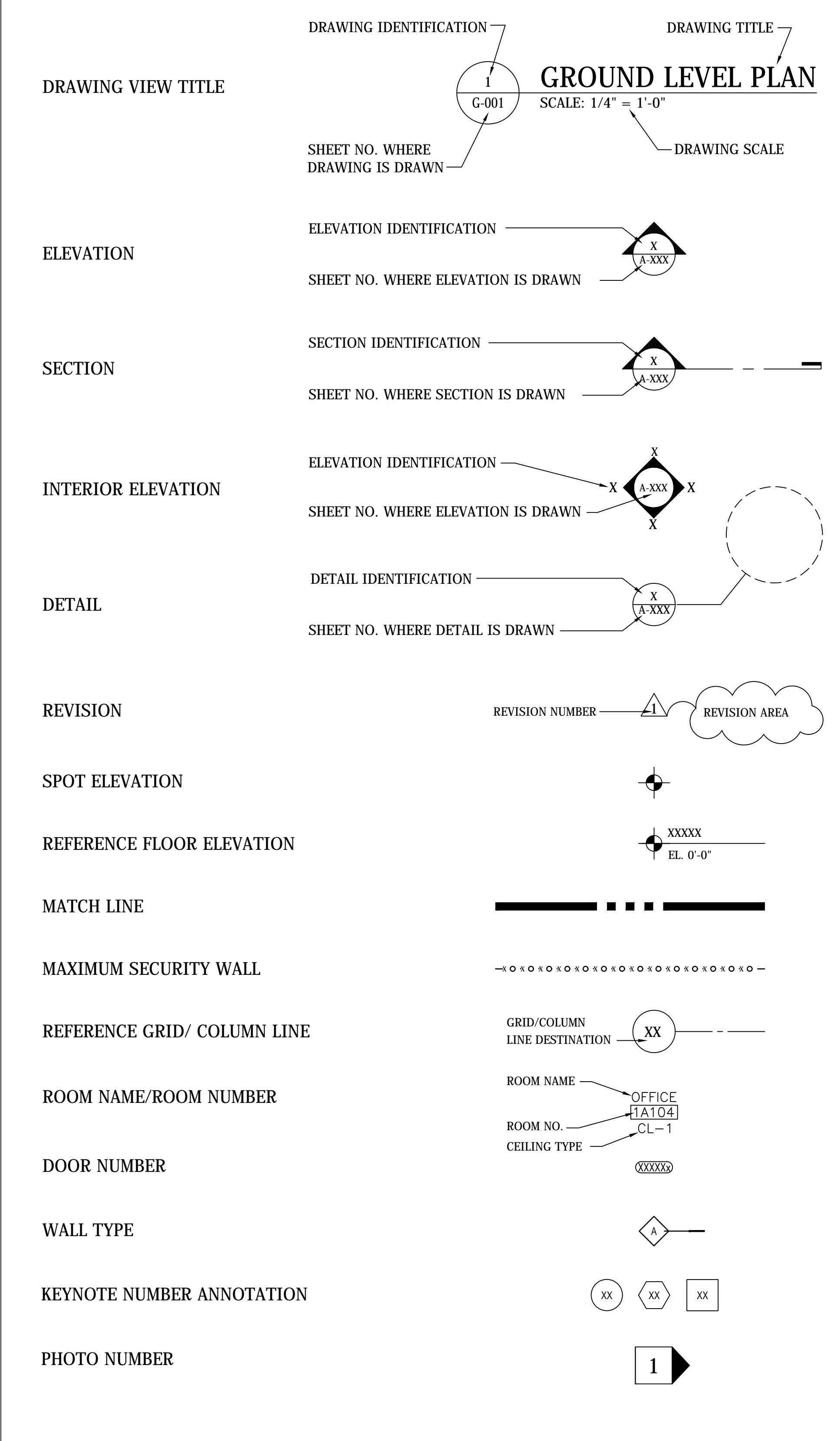

LIST OF DRAWINGS

SHEET NUMBER	DRAWING NUMBER	DRAWING TITLE
GENERAL		
1 OF 16	G-000	COVER SHEET
2 OF 16	G-001	DRAWINGS INDEX, SYMBOLS & NOTES
ARCHITECTURAL / STRUCTURAL		
3 OF 16	A-101	ADMINISTRATION MODULE - BASEMENT LEVEL PART PLAN
4 OF 16	A-401	ADMINISTRATION MODULE - INTERIOR ELEVATIONS
5 OF 16	A-801	DETAILS I
6 OF 16	A-802	DETAILS II
HVAC		
7 OF 16	M-001	MECHANICAL NOTES, ABBREVIATIONS, AND LEGEND
8 OF 16	M-101	ADMINISTRATION MODULE - BASEMENT LEVEL PART PLAN - DUCTWORK
9 OF 16	M-201	ADMINISTRATION MODULE - BASEMENT LEVEL PART PLAN - PIPING
10 OF 16	M-501	HVAC DETAILS I
11 OF 16	M-502	HVAC DETAILS II
12 OF 16	M-503	HVAC DETAILS III
13 OF 16	M-504	HVAC DETAILS IV
14 OF 16	M-601	HVAC SCHEDULES
ELECTRICAL		
15 OF 16	E-001	ELECTRICAL NOTES, ABBREVIATIONS AND LEGEND
16 OF 16	E-101	ADMINISTRATION MODULE - BASEMENT LEVEL PART PLAN - POWER

ABBREVIATION

Symbol	Description	Symbol	Description	Symbol	Description
&	AND	DIFF	DIFFUSER	MISC	MISCELLANEOUS
@	AT	DN	DOWN		
⊕	CENTERLINE	DO	DOOR OPENING OR DITTO	N/A	NOT APPLICABLE
∅	DIAMETER or ROUND	DOC	DEPARTMENT F CORRECTION (DC)	NTS	NOT TO SCALE
(E)	EXISTING	DR	DOOR	OA	OVERALL
ABV	ABOVE	EA	EACH	OC	ON CENTER
ACCESS	ACCESSIBLE	EJ	EXPANSION JOINT	OD	OUTSIDE DIMENSION OR DIAMETER
ACOUS	ACOUSTICAL	ELEC	ELECTRICAL		
ACP	ACOUSTICAL PANEL	EMER	EMERGENCY	PART	PARTIAL
ACT	ACOUSTIC TILE	EQUIP	EQUIPMENT	PNL	PANEL
AD	ACCESS DOOR OR AREA DRAIN	EXIST	EXISTING	PR	PAIR
ADDL	ADDITIONAL	EXP.	EXPANSION	PTD	PAINTED
ADH	ADHESIVE			RE:	REFER
ADJ	ADJUSTABLE	FAC	FACILITY	REINF.	REINFORCEMENT
AF	ACCESS FLOOR	FD	FLOOR DRAIN	RAD	RADIUS
AFF	ABOVE FINISH FLOOR	FE	FIRE EXTINGUISHER	RM	ROOM
ALT	ALTERNATE	FIN	FINISH	SAN	SANITARY
AP	ACCESS PANEL	FL	FLOOR	SCHED	SCHEDULED
APPROX	APPROXIMATE	GA	GAUGE	SGL	SINGLE
B	BASE	H	HEIGHT	SS	STAINLESS STEEL or SERVICE SINK
BAL	BALCONY	HM	HOLLOW METAL	STL	STEEL
B BD	BULLETIN BOARD	HVAC	HEATING, VENTILATION AND AIR CONDITIONING		
BD	BOARD			TEL	TELEPHONE
BET	BETWEEN	INSUL	INSULATION	THK	THICK
BLDG	BUILDING	INT	INTERIOR	TYP	TYPICAL
BLK	BLOCK			UH	UNIT HEATER
CCTV	CLOSED CIRCUIT TELEVISION	JAN	JANITOR	UON	UNLESS OTHERWISE NOTED
CEM	CEMENT, CEMENTITIOUS	JC	JANITOR CLOSET		
CER	CERAMIC	JT	JOINT	VERT	VERTICAL
CH	CEILING HEIGHT OR CHANNEL			VIF	VERIFY IN FIELD
CIP	CAST IN PLACE	L	LENGTH		
CJ	CONTROL JOINT	LAV	LAVATORY	WIND	WINDOW
CMU	CONCRETE MASONRY UNIT	LLV	LONG LEG VERTICAL	WT	WEIGHT
CONC	CONCRETE	LO	LOUVER OPENING		
CONT	CONTINUOUS OR CONTINUATION	LTG	LIGHTING		
COTR	CONTRACTING OFFICER'S TECHNICAL REPRESENTATIVE	MATL	MATERIAL		
CTR'D	CENTERED	MECH	MECHANICAL		
DEMO	DEMOLITION	MEP	MECHANICAL, ELECTRICAL, PLUMBING		
DIA	DIAMETER	MTL	METAL		

100% CONSTRUCTION DOCUMENTS

DESIGNED: CCJM					
DRAWN: CCJM					
CHECKED: CCJM					
REVISION	DATE	DESCRIPTION	BY	APP.	
PROJECT DRAWINGS					
DRAWINGS INDEX, SYMBOLS & NOTES				GENERAL	
MAINTENANCE SHOP HVAC & LAUNDRY ROOM ALTERATIONS CENTRAL DETENTION FACILITY (D.C. JAIL) DEPARTMENT OF CORRECTIONS DISTRICT OF COLUMBIA				G-001	
I HEREBY CERTIFY THAT THESE DOCUMENTS WERE PREPARED OR APPROVED BY ME, AND THAT I AM A DULY LICENSED ARCHITECT / PROFESSIONAL ENGINEER UNDER THE LAWS OF THE DISTRICT OF COLUMBIA					
REGISTRATION NO. AR-102102		CCJM C.C. Johnson & Malhotra, P.C. 1025 Connecticut Ave., N.W., Suite 1017 Washington, DC 20036		BUILDING ID NO.: 299	
ARCHITECT/ENGINEER		GOVERNMENT OF THE DISTRICT OF COLUMBIA DEPARTMENT OF GENERAL SERVICES		PROJECT NO.: CR-104C	
EXP. DATE: 04/30/2016				DATE: APR 6, 2016	
				SHEET: 2 OF 16	

C.C. Johnson & Malhotra, P.C. East River by Urban River Drive, 417-2010, 11 E.T. Pl., New York, New York 10002-3000. Telephone: 212-691-1111. Fax: 212-691-1112. Website: www.ccmj.com. License No. AR-102102. The Name of the Firm: C.C. Johnson & Malhotra, P.C. License No. AR-102102. License No. AR-102102. License No. AR-102102. License No. AR-102102.

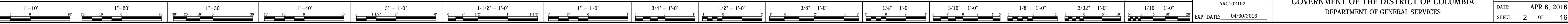

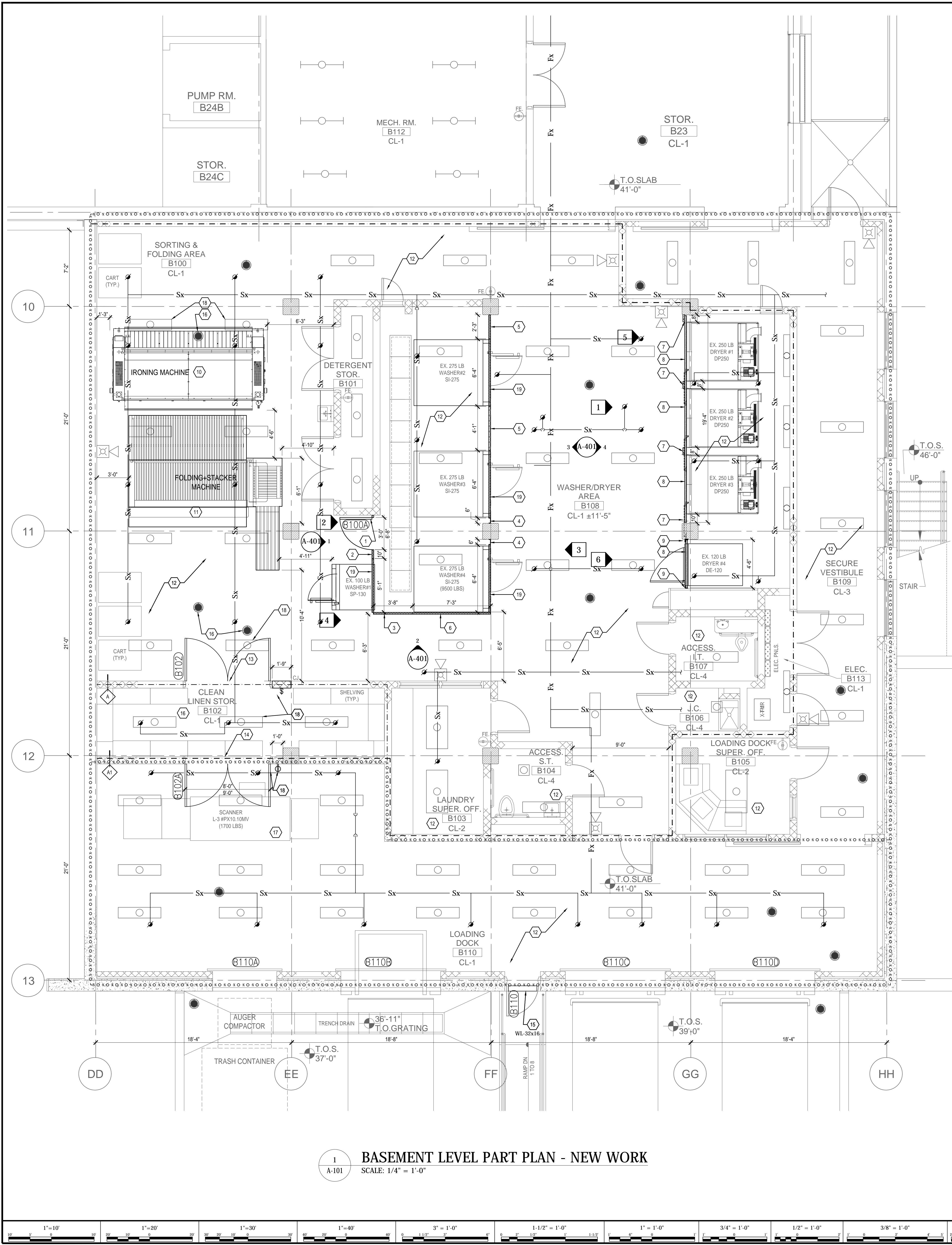

1 BASEMENT LEVEL PART PLAN - NEW WORK
SCALE: 1/4" = 1'-0"

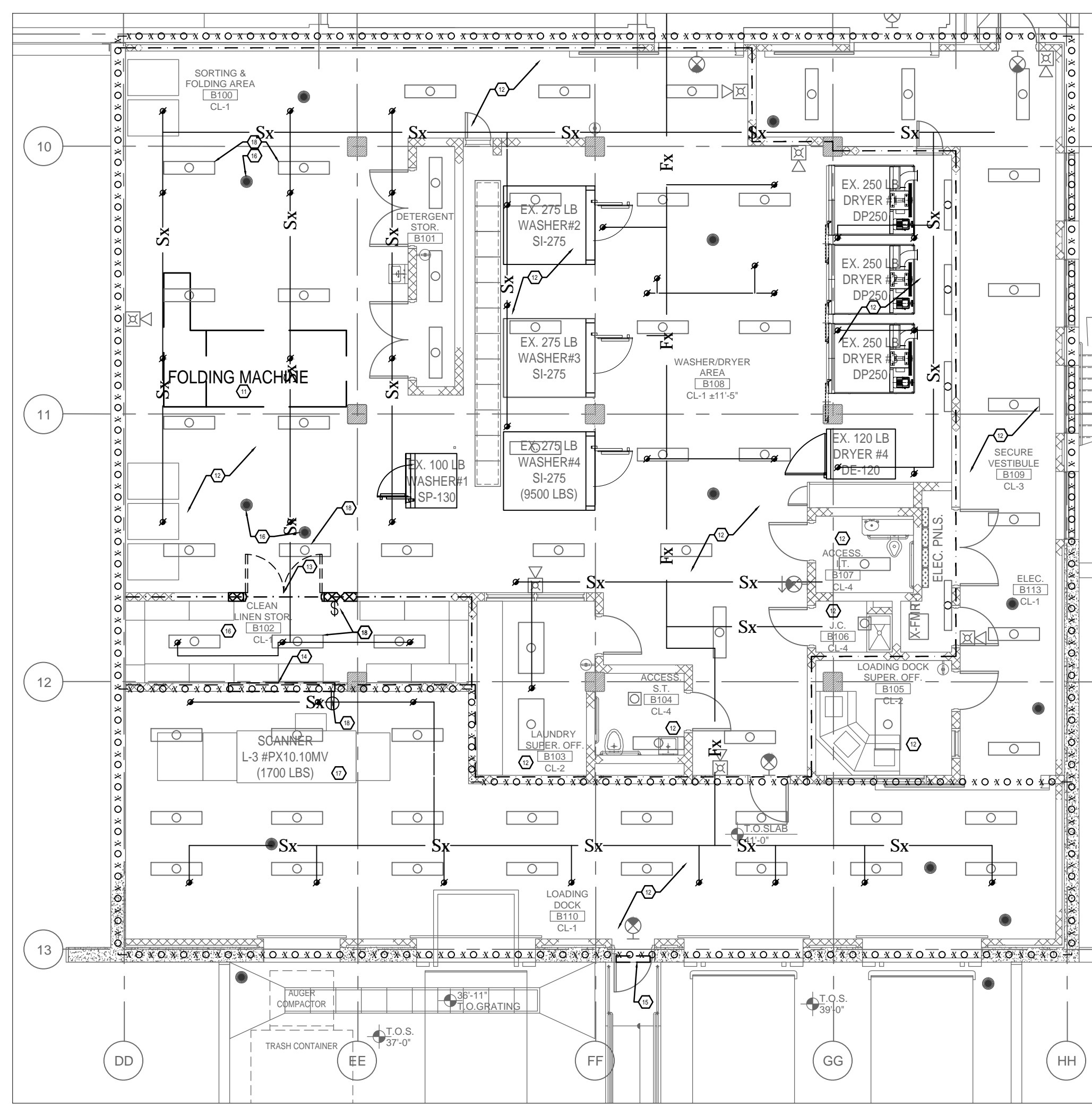

2 BASEMENT LEVEL PART PLAN - DEMOLITION WORK
SCALE: 1/8" = 1'-0"

LEGEND

	EXISTING WALL, DOOR, WINDOW, ETC. TO REMAIN
	REMOVE EXISTING WALL, DOOR AND HARDWARE, DOOR FRAME, WINDOW, ETC.
	REMOVE BUILT-IN CASEWORK, EQUIPMENT, PLUMBING FIXTURE, TOILET PARTITION, ETC.
	EXISTING WALL, DOOR, WINDOW, ETC. TO REMAIN
	1-HOUR FIRE RESISTANCE RATED SEPARATION (UL 900), 45 MINUTES RATED DOORS
	WIRE MESH SS PANEL
	INSULATED SS PANEL
	FIRE ALARM - HORN & STROBE
	FIRE EXTINGUISHER
	CEILING MOUNTED CCTV CAMERA
	LIGHT FIXTURE
	EXIST SPRINKLER PIPING W/ SPRINKLER HEAD

- GENERAL NOTES**
- ALL DIMENSIONS AND EXISTING CONDITIONS SHALL BE VERIFIED AT THE SITE BY THE CONTRACTOR. NOT ALL INFORMATION SHOWN.
 - BEFORE STARTING WORK MAKE A THOROUGH EXAMINATION OF THOSE PORTIONS OF THE STRUCTURE IN WHICH THE WORK IS TO BE PERFORMED. CHECK ALL THE WORK ADDING, AT OVERHEAD LOCATIONS, AND LOCATIONS BELOW THE FLOOR. REPORT TO THE DOC & CUTS ANY AND ALL CONDITIONS WHICH MAY INTERFERE WITH OR OTHERWISE AFFECT OR PREVENT THE PROPER EXECUTION AND COMPLETION OF THE WORK. DO NOT START THE WORK UNTIL SUCH CONDITIONS HAVE BEEN EXAMINED AND COURSES OF ACTION HAVE BEEN MUTUALLY AGREED UPON.
 - EXISTING FINISHES TO REMAIN THAT ARE DISTURBED BY DEMOLITION SHALL BE REFINISHED TO MATCH EXISTING ADJACENT SURFACES. REPAIR AND/OR REPLACE ALL EXISTING CONSTRUCTION NOT SCHEDULED OR NOTED TO BE DEMOLISHED OR NOT SPECIFIED TO BE REMOVED, BUT WHICH IS REMOVED FOR OR BECOMES DAMAGED BY THE WORK. REPLACEMENTS AND MODIFICATIONS SHALL RESTORE REMOVED OR DAMAGED CONSTRUCTION TO ITS ORIGINAL CONDITION AND CONSTRUCTION AT THE TIME OF REMOVAL OR DAMAGE, TO THE SATISFACTION OF CONTRACTING OFFICER AND AT NO ADDITIONAL COST.
 - BEFORE STARTING DEMOLITION OPERATIONS, PROVIDE THE NECESSARY PROTECTIVE DEVICES WHERE REQUIRED, AND IN STRICT ACCORDANCE WITH OSHA RULES AND REGULATIONS.
 - REMOVAL OF EXISTING DOORS, PARTITIONS, AND/OR EQUIPMENT MAY RESULT IN DAMAGE TO EXISTING FINISHES THAT ARE INTENDED TO REMAIN. THE CONTRACTOR SHALL BE RESPONSIBLE FOR REPAIRING, SMOOTH AND LEVEL ALL FINISHED TO MATCH EXISTING UNLESS NOTED OTHERWISE.
 - CONTRACTOR MUST HAVE SEPARATE CONTAINERS FOR WASTE AND RECYCLING. WASTE MATERIALS SHALL BECOME THE PROPERTY OF THE CONTRACTOR AND SHALL BE DISPOSED OF OFF THE SITE. ON A REGULAR BASIS, IN A LEGAL MANNER. RECYCLABLE MATERIALS SHALL BECOME THE PROPERTY OF THE CONTRACTOR AND SHALL BE RECYCLED. COORDINATE COLLECTION SITE WITH THE DOC & CUTS.
 - PATCH, FILL AND REPAIR ALL SURFACES DISTURBED, CUT, DAMAGED, IN NEED OF REPAIR OR MADE IMPERFECT BY ALTERATIONS OR REMOVAL WORK AND AS REQUIRED TO PREPARE SURFACES FOR NEW MATERIALS AND ARRANGEMENTS.
 - PRIOR TO THE DEMOLITION OF THOSE ITEMS WHICH HAVE UTILITY CONNECTIONS (WATER, GAS, ELECTRICITY, STEAM, WASTE, HYDRONIC, COMPRESSED AIR, ETC.) THE CONTRACTOR SHALL ARRANGE WITH THE DOC TO LOCATE SHUTOFF VALVES, PANEL BOARDS AND OTHER CONTROL ELEMENTS, SO THAT WATER DAMAGE AND OTHER POTENTIALLY INCONVENIENT OR DANGEROUS OR SECURITY SITUATIONS ARE AVOIDED.
 - NO UTILITY SERVICES SHALL BE INTERRUPTED BY THE CONTRACTOR FOR ANY PURPOSE WITHOUT PRIOR WRITTEN APPROVAL OF THE CONTRACTING OFFICER AND SHALL REQUIRE APPROPRIATE ADVANCE NOTICES.
 - ITEMS INDICATED TO BE REMOVED AND RE-USED/RE-INSTALLED SHALL BE PROTECTED DURING DEMOLITION AND CONSTRUCTION ACTIVITIES.
 - EXISTING FIRE AND SECURITY BARRIERS SHALL BE MAINTAINED DURING DEMOLITION AND CONSTRUCTION. FIRESTOP ALL EXISTING PENETRATIONS IN FIRE BARRIERS THAT ARE NOT PROTECTED, AND FIRESTOP ALL NEW PENETRATIONS.
 - ALL EXISTING ARCHITECTURAL, STRUCTURAL, MECHANICAL, ELECTRICAL, PLUMBING, AND FIRE PROTECTION DRAWINGS FOR ADDITIONAL REQUIREMENTS & COORDINATE ALL WORK.
 - WIRE MESH STAINLESS STEEL (SS) PANELS: 2" STAINLESS STEEL SQUARE TUBE FRAME, WITH 3/4" #9 FLATTENED EXPANDED WIRE MESH WELDED ON THE EXPOSED SIDE AND GRIND SMOOTH ALL WELDS. FIELD VERIFY EXISTING EQUIPMENT LOCATION AND PROVIDE FOR MINIMUM 1" CLEARANCE AROUND EXISTING OBSTRUCTIONS AND EQUIPMENT. PANELS SHALL BE REMOVABLE FOR SERVICE AND EQUIPMENT ACCESS. FIELD VERIFY AND PROVIDE OPENINGS FOR EXISTING PENETRATING ITEMS SUCH AS CONDUITS, PIPING, DUCTWORK, HANGERS, SUPPORTS, ETC. REPLACE AND RELOCATE EXISTING HANGERS & SUPPORTS TO SUIT NEW PANELS, AS REQUIRED.
 - INSULATED STAINLESS STEEL PANELS: 2" INSULATED STAINLESS STEEL PANELS MOUNTED ON TRAKS BOLTED TO THE CEILING AND THE SIDE PANELS FRAME/ANGLE CHANNELS. SS BARS TO BE MOUNTED AROUND PENETRATIONS AND SECURED TO SUIT POST FRAME. PANELS SHALL BE REMOVABLE FOR SERVICE AND EQUIPMENT ACCESS. FIELD VERIFY AND PROVIDE OPENINGS FOR EXISTING PENETRATING ITEMS SUCH AS CONDUITS, PIPING, DUCTWORK, HANGERS, SUPPORTS, ETC. REPLACE AND RELOCATE EXISTING HANGERS & SUPPORTS TO SUIT NEW PANELS, AS REQUIRED.

- KEYED NOTES**
- WIRE MESH DOOR PANEL: 36" x 80" WIRE MESH TRANSOM PANELS ABOVE WIRE MESH DOOR PANEL.
 - WIRE MESH FLOOR TO CEILING SIDE PANEL & TRANSOM PANELS IN MULTIPLE SECTIONS.
 - WIRE MESH FLOOR TO CEILING SIDE PANEL, IN TWO SECTIONS.
 - WIRE MESH SIDE PANEL OR C6 x 10.5 STAINLESS STEEL CHANNEL, SIDE FILLETS ANCHORED TO COLUMN.
 - WIRE MESH TRANSOM PANEL ABOVE EACH WASHER.
 - WIRE MESH TRANSOM SIDE PANEL, SUSPENDED FROM CEILING ABOVE WASHER.
 - WIRE MESH SIDE FILLER PANEL OR STAINLESS STEEL C CHANNEL SIDE FILLETS ANCHORED AT BOTTOM AND TOP.
 - INSULATED STAINLESS STEEL PANELS IN REMOVABLE SECTIONS ABOVE DRYERS.
 - STAINLESS STEEL ANGLE FILLER ANCHORED TO COLUMN/METAL WALL.
 - DOC VENDOR/CONTRACTOR WILL FURNISH AND INSTALL NEW IRONING MACHINE B&C TECHNOLOGIES MODEL IR-4030 UNDER SEPARATE CONTRACT. COORDINATE AND SCHEDULE WORK AND PROVIDE UTILITIES W/ FINAL CONNECTIONS AND ASSOCIATED MEP SYSTEMS AS SHOWN ON MEP DRAWINGS UNDER THIS CONTRACT.
 - DOC VENDOR/CONTRACTOR WILL DISCONNECT & RELOCATE EXISTING FOLDER MACHINE & STACKER TO ALLOW NEW IRONING MACHINE INSTALLATION AND WILL ROTATE AND RE-INSTALL FOLDER MACHINE & STACKER TO ALIGN WITH IRONING MACHINE PROCESS FLOW. REFER TO MEP DRAWINGS FOR UTILITIES REMOVAL UNDER THIS CONTRACT.
 - EXISTING TO REMAIN UNLESS OTHERWISE INDICATED.
 - REMOVE & SALVAGE EXISTING 72x84 HOLLOW METAL DOOR W/ FRAME (45 MIN. FIRE RATED) & HARDWARE. ENLARGE OPENING TO SUIT NEW DOORS. PROVIDE NEW HOLLOW METAL DOOR WITH FRAME, HARDWARE & FINISH. PATCH WALL, FLOOR, CHILLING, AND FINISH TO MATCH EXISTING.
 - REMOVE REINFORCED MAXIMUM SECURITY 8" CMU REINFORCED WALL FOR NEW DOORS. PROVIDE NEW DETENTION GRADE HOLLOW METAL DOOR WITH FRAME & LINTEL. PATCH WALL TO MAXIMUM SECURITY CONSTRUCTION & FINISH TO MATCH EXISTING.
 - CUT WALL CONSTRUCTED OF 14" REINFORCED CIP CONCRETE, 2" CAVITY INSULATION & 6" CMU FOR NEW LOUVER OPENING. PROVIDE NEW LOUVER, SECURITY BAR-GRILLE, BIRD/INSECT SCREEN, LINTEL, AND PATCH WALL & FINISH TO MATCH EXISTING ON BOTH SIDES.
 - DOC WILL CLEAR ROOM STOCK & SHELVES. REMOVE AND REINSTALL SECURITY CAMERA TO ALLOW PROJECT WORK. COORDINATE AND SCHEDULE WORK WITH MINIMUM DOWNTIME FOR THE DOC OPERATIONS.
 - CONTRACTOR WILL ENGAGE VENDOR SERVICES FOR EXISTING SCANNER TO DISCONNECT, RELOCATE AT TEMPORARY LOCATION IN THE SAME LOADING AREA, REINSTALL AND RECONNECT BACK TO EXISTING LOCATION UNDER SEPARATE CONTRACT. COORDINATE AND SCHEDULE WORK WITH MINIMUM DOWNTIME FOR THE DOC OPERATIONS.
 - REMOVE AND RELOCATE LIGHT SWITCH, SCANNER POWER RECEPTACLE UV LIGHT, ETC. TO CLEAR NEW DOORS. REMOVE AND REINSTALL LIGHTS INTERFERING WITH IRONING UNIT REGGING AND INSTALLATION-TYPICAL.
 - WIRE MESH PANELS ABOVE EQUIPMENT: WASHER #1, WASHER #2, WASHER #3, WASHER #4.

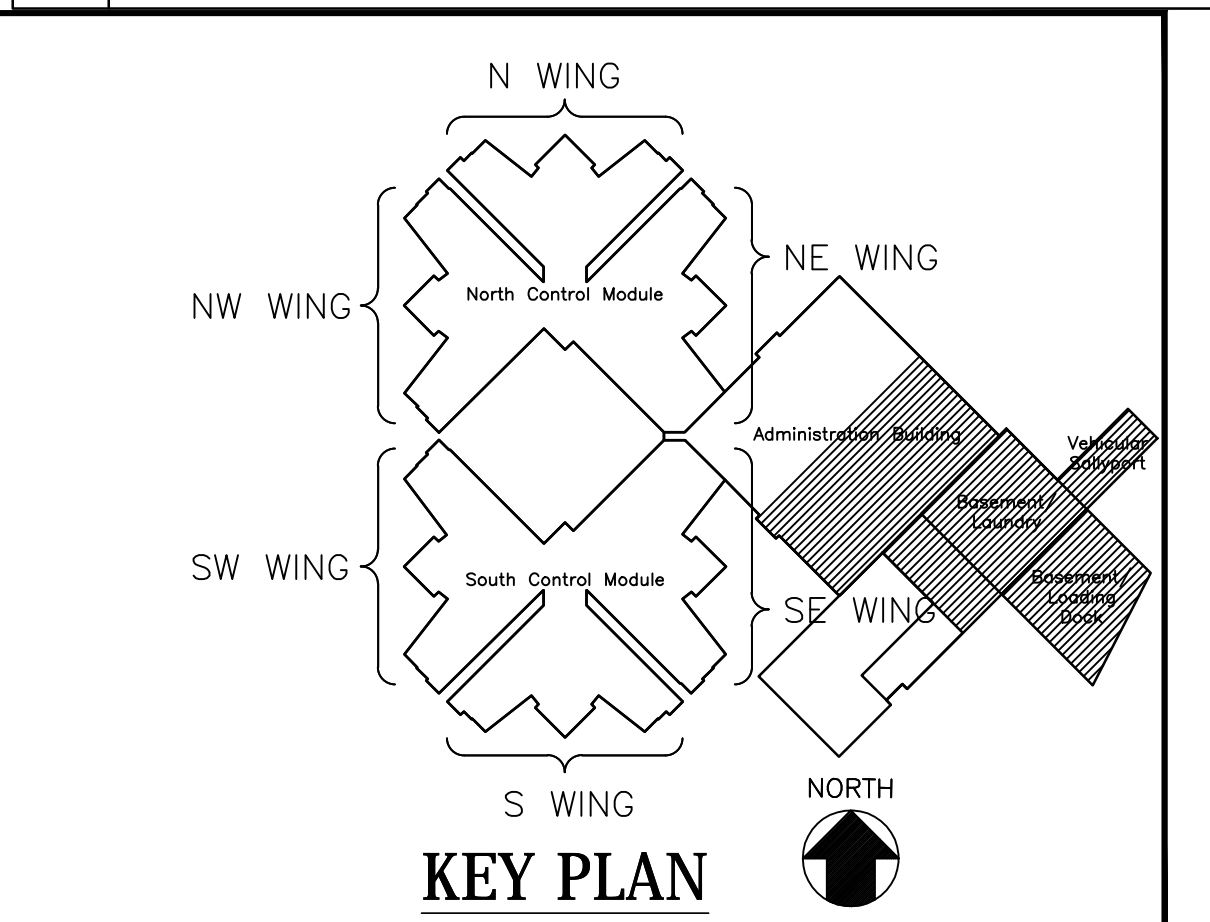

100% CONSTRUCTION DOCUMENTS

DESIGNED: CMN	CHECKED: CCJM	REVISION	DATE	DESCRIPTION	BY	APP.
<p>CERTIFICATION</p> <p>I HEREBY CERTIFY THAT THESE DOCUMENTS WERE PREPARED OR APPROVED BY ME, AND THAT I AM A DULY LICENSED ARCHITECT / PROFESSIONAL ENGINEER UNDER THE LAWS OF THE DISTRICT OF COLUMBIA</p>		<p>PROJECT DRAWINGS</p> <p>ADMINISTRATION MODULE - BASEMENT LEVEL PART PLAN</p>			<p>ARCH</p> <p>DRAWING NO.</p> <p>A-101</p>	
<p>REGISTRATION NO. _____</p> <p>EXP. DATE: _____</p> <p>ARCHITECT/ENGINEER</p> <p>ARC102102</p> <p>EXP. DATE: 04-30-2016</p>		<p>CCJM C.C. Johnson & Malhotra, P.C.</p> <p>1025 Connecticut Ave., N.W., Suite 1017 Washington, DC 20036</p>			<p>BUILDING ID NO.: 299</p> <p>PROJECT NO.: CR-104C</p> <p>DATE: APR 6, 2016</p> <p>SHEET: 3 OF 16</p>	
<p>GOVERNMENT OF THE DISTRICT OF COLUMBIA DEPARTMENT OF GENERAL SERVICES</p>						

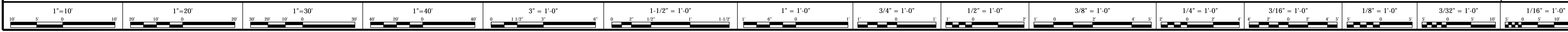

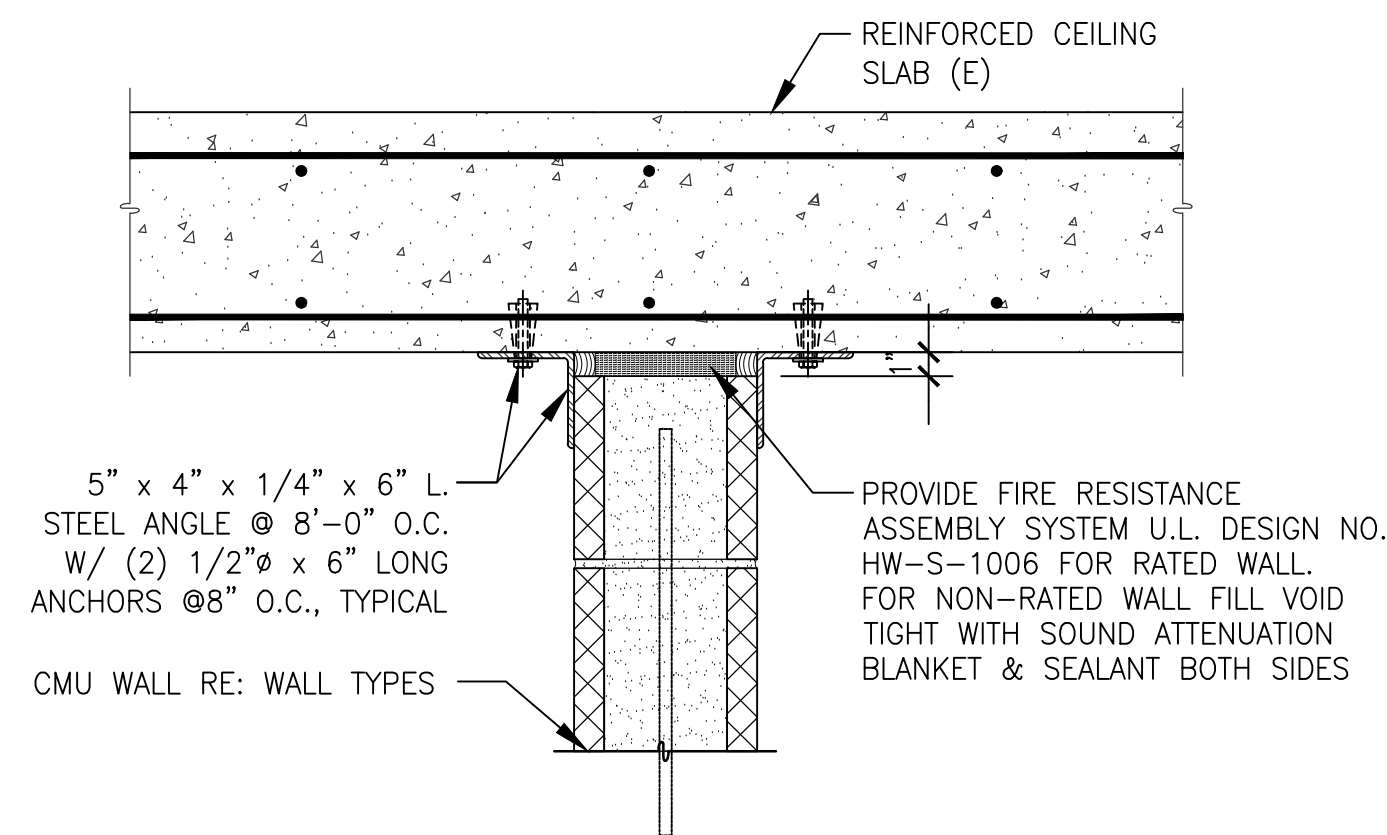

- NOTES:**
1. GROUT CMU CELLS AT VERTICAL REINFORCING ONLY.
 2. VERTICAL AND HORIZONTAL REINFORCING LAP SPICES ARE 48 BAR DIAMETER UNLESS NOTED OTHERWISE.
 3. ANCHOR ALL VERTICAL REINFORCEMENT TO FOUNDATION USING MATCHING DOWELS.
 4. PROVIDE ADDITIONAL (2) #5 VERTICAL REINFORCEMENT EACH SIDE OPENING AND CONTROL JOINT. DISCONTINUE HORIZONTAL REINFORCEMENT AT EACH CONTROL JOINT.
 5. PROVIDE CONTINUOUS 9 GAGE TRUSS TYPE HORIZONTAL JOINT REINFORCEMENT @ 16" O.C.
 6. REINFORCE CMU CORES AT ALL CORNERS w/ (2) #6.
 7. USE BOND BEAM W/ 2-#5 MINIMUM AT TOP AND BOTTOM OF WALL AND 10'-0" CENTERS MAXIMUM.
 8. EXTERIOR LOCATION APPLIES WHERE CMU WALL OR FINISH ON CMU WALL IS DIRECTLY EXPOSED TO WIND, INCLUDING INTERIOR WALLS LOCATED IN WIND PATHS. INTERIOR LOCATION APPLIES WHERE CMU WALL IS NOT DIRECTLY EXPOSED TO WIND.

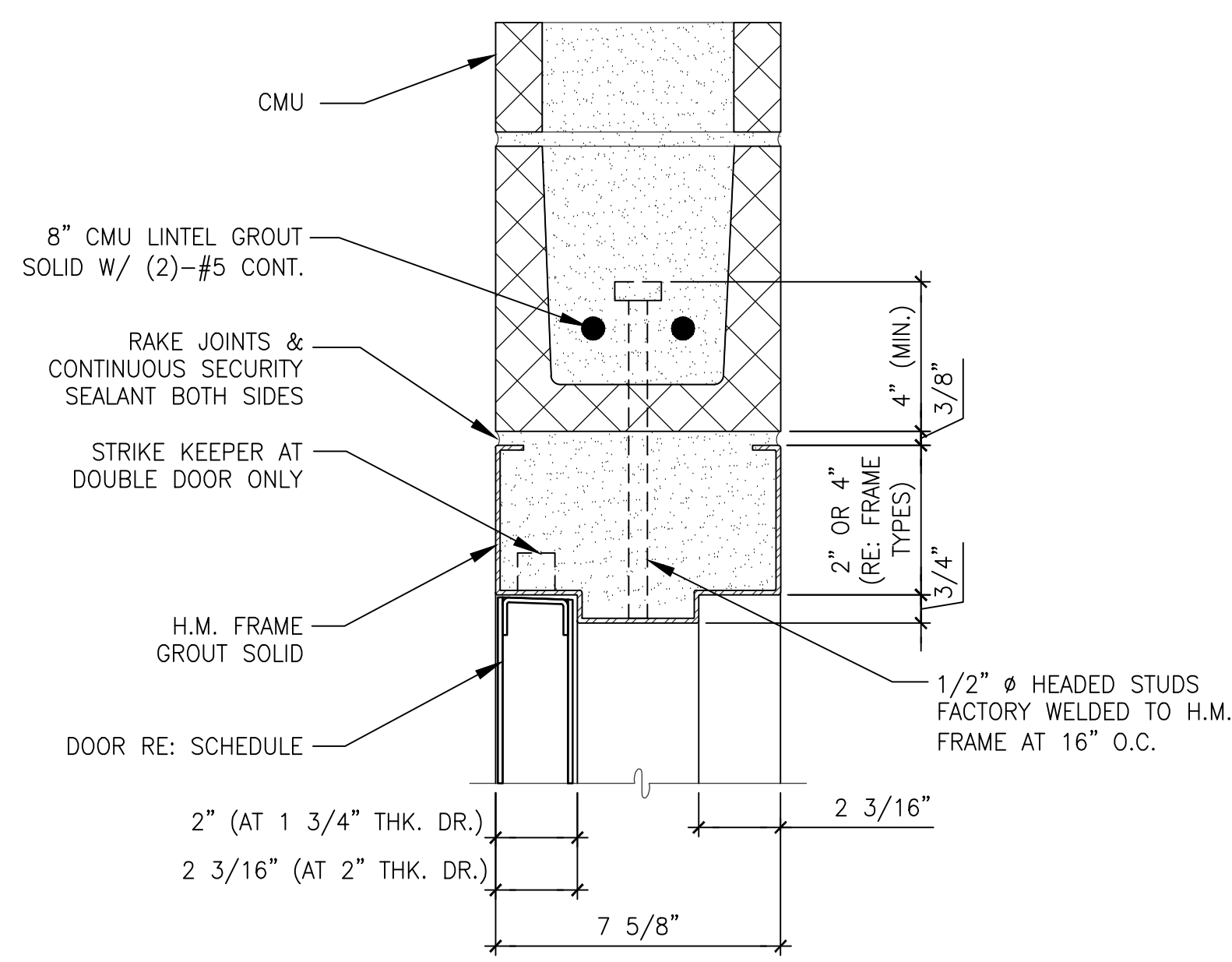

2 SWING DOOR HEAD DETAIL
SCALE: 3" = 1'-0"

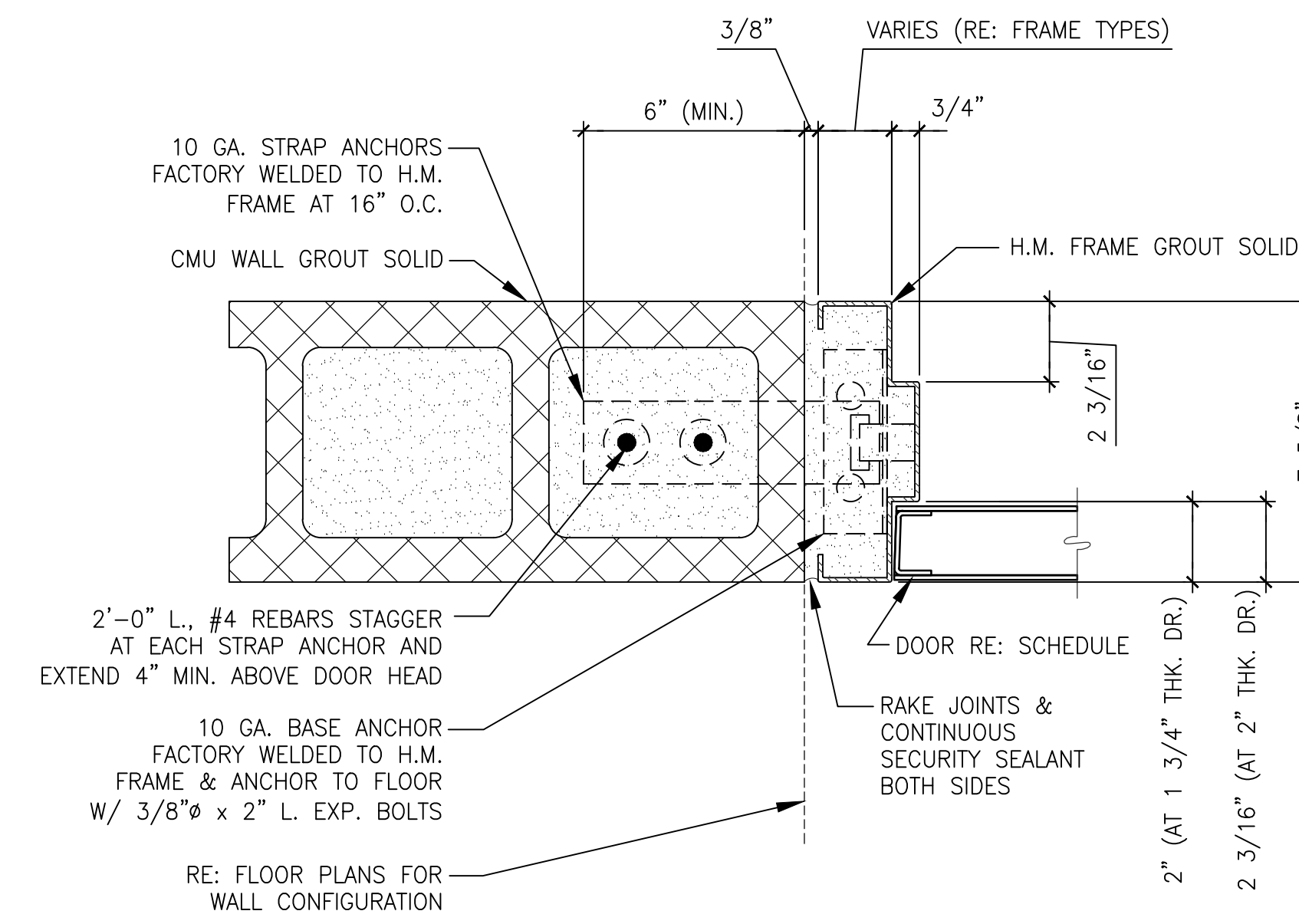

3 SWING DOOR JAMB DETAIL
SCALE: 3" = 1'-0"

- GENERAL NOTES**
1. DETENTION AND NON-DETENTION DOOR AND WINDOW FRAMES SHALL BE GROUTED SOLID UNLESS OTHERWISE NOTED.
 2. DOOR UNDERCUT SHALL BE COORDINATED WITH SCHEDULE THRESHOLD AND SHALL NOT EXCEED 1/2" UNLESS OTHERWISE NOTED.
 3. ALL FRAMES WELDING TO WALLS, BEAMS ETC. SHALL BE RECESSED 1/4" MINIMUM TO ALLOW SEALANT INSTALLATION.
 4. COORDINATE ALL PENETRATIONS WITHIN FRAME WITH CONTRACT DOCUMENTS.
 5. PROVIDE A SECURITY BAR-GRILLE BEHIND ALL NEW EXTERIOR LOUVERS.
- SECURITY WALL CONSTRUCTION**
1. **MAXIMUM SECURITY CMU WALL:**
NORMAL WEIGHT CMU PER ASTM C90 GRADE N, TYPE II AND MORTAR PER ASTM C270, TYPE M, FILLED SOLID AND REINFORCED WITH #4 REINFORCEMENT STEEL AT EIGHT INCHES ON CENTER VERTICALLY AND HORIZONTALLY.
 2. **MAXIMUM SECURITY CAST-IN-PLACE CONCRETE WALL:**
4000 PSI CAST-IN-PLACE CONCRETE AND SHALL RECEIVE SECURITY REINFORCEMENT CONSISTING OF ONE LAYER OF WELDED WIRE MESH W/ 0 x 4 @ 4 x 4, OR 5000 PSI CONCRETE WITH #4 REINFORCEMENT STEEL AT EIGHT INCHES ON CENTER VERTICALLY AND HORIZONTALLY.
 3. **MAXIMUM SECURITY METAL WALL:**
FULL HEIGHT, FULLY GROUTED/INSULATED. REFER TO SPECIFIC DETAILS AND SPECIFICATIONS FOR WELDING, ANCHORING SIZE AND SPACING.

1 WALLS INTERFACE WITH UNDERSIDE OF STRUCTURE / PANEL
SCALE: 1 1/2" = 1'-0"

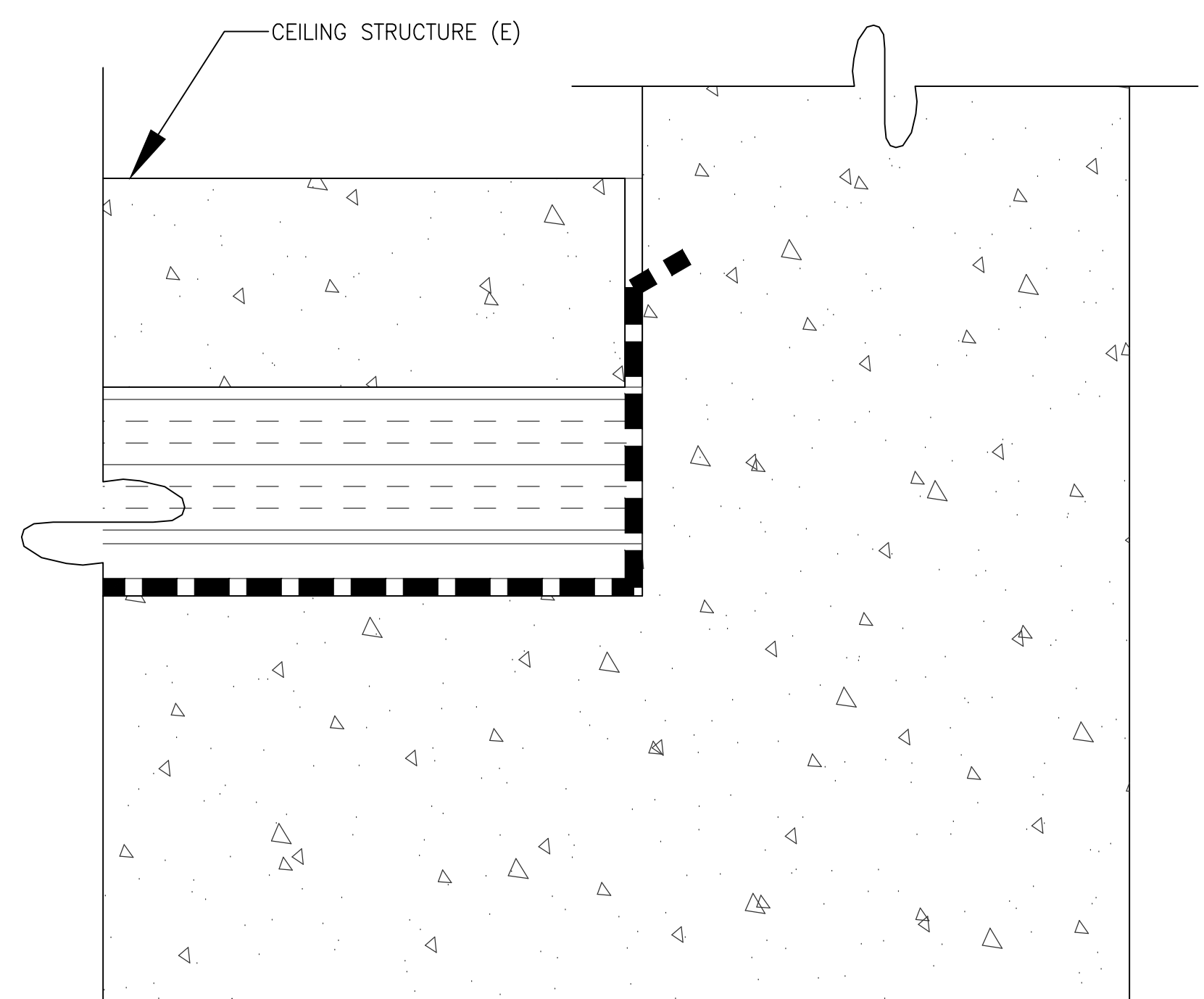

4 LOUVER HEAD DETAIL
SCALE: 3" = 1'-0"

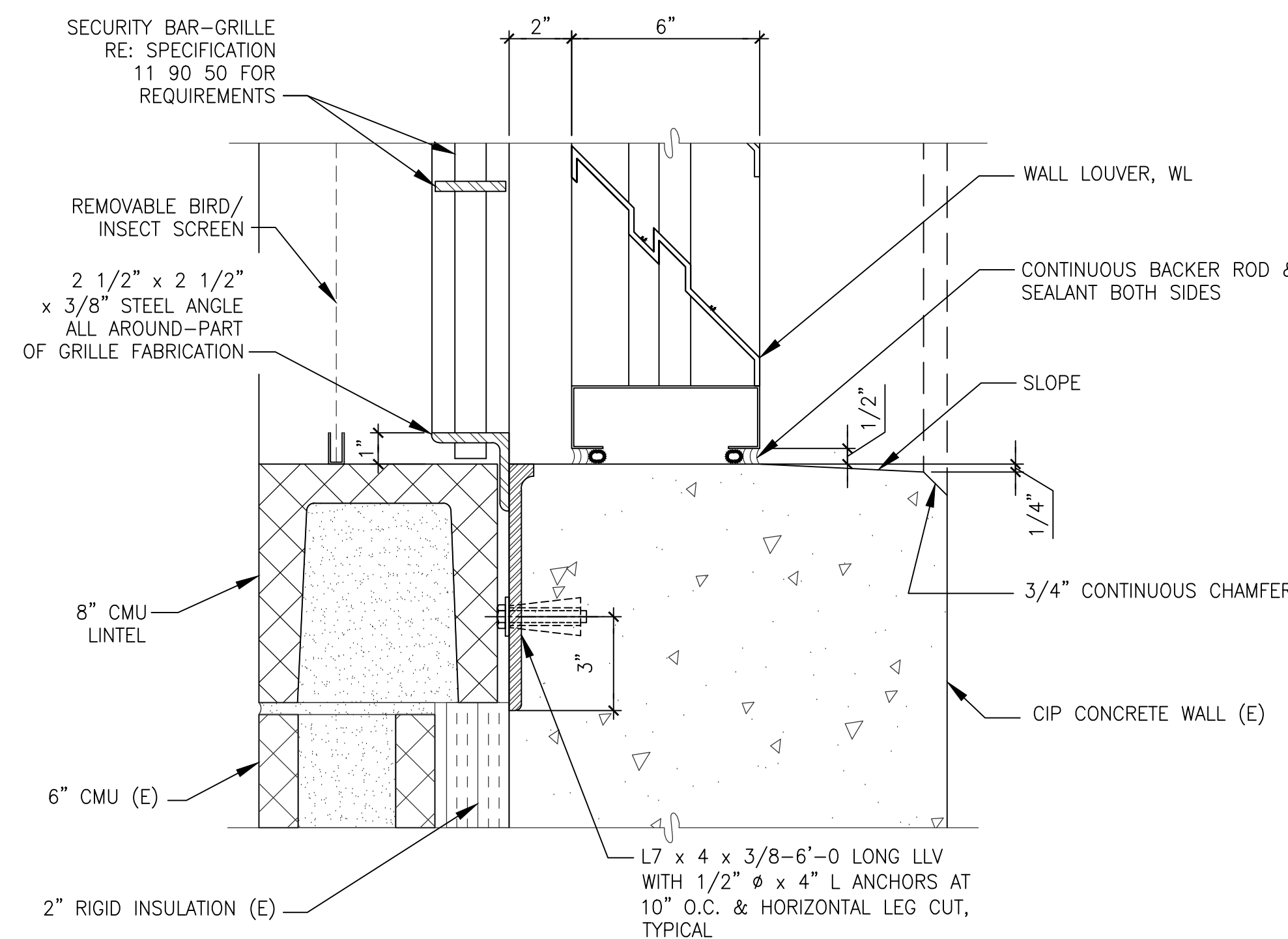

5 LOUVER SILL DETAIL
SCALE: 3" = 1'-0"

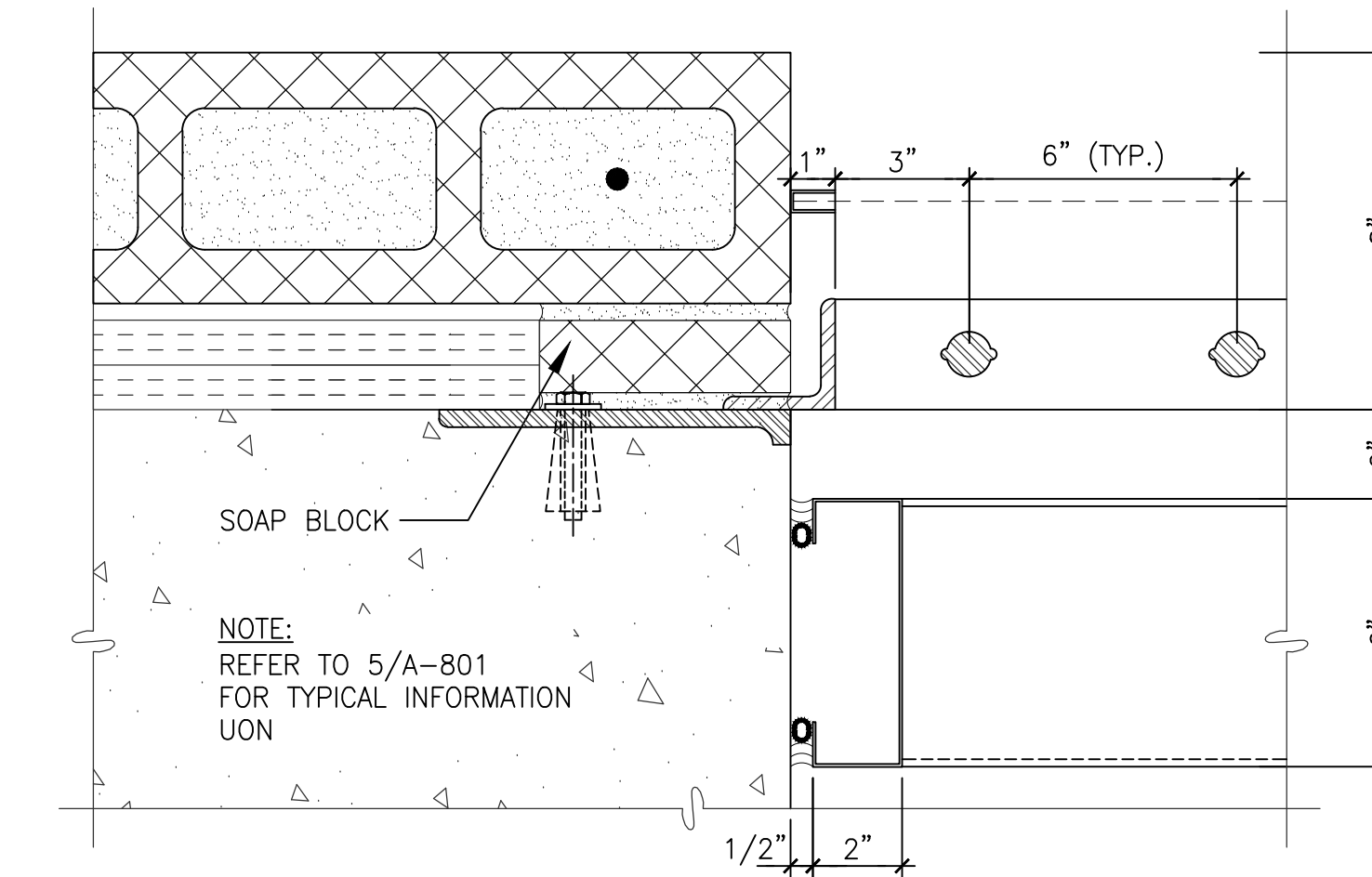

6 LOUVER JAMB DETAIL
SCALE: 3" = 1'-0"

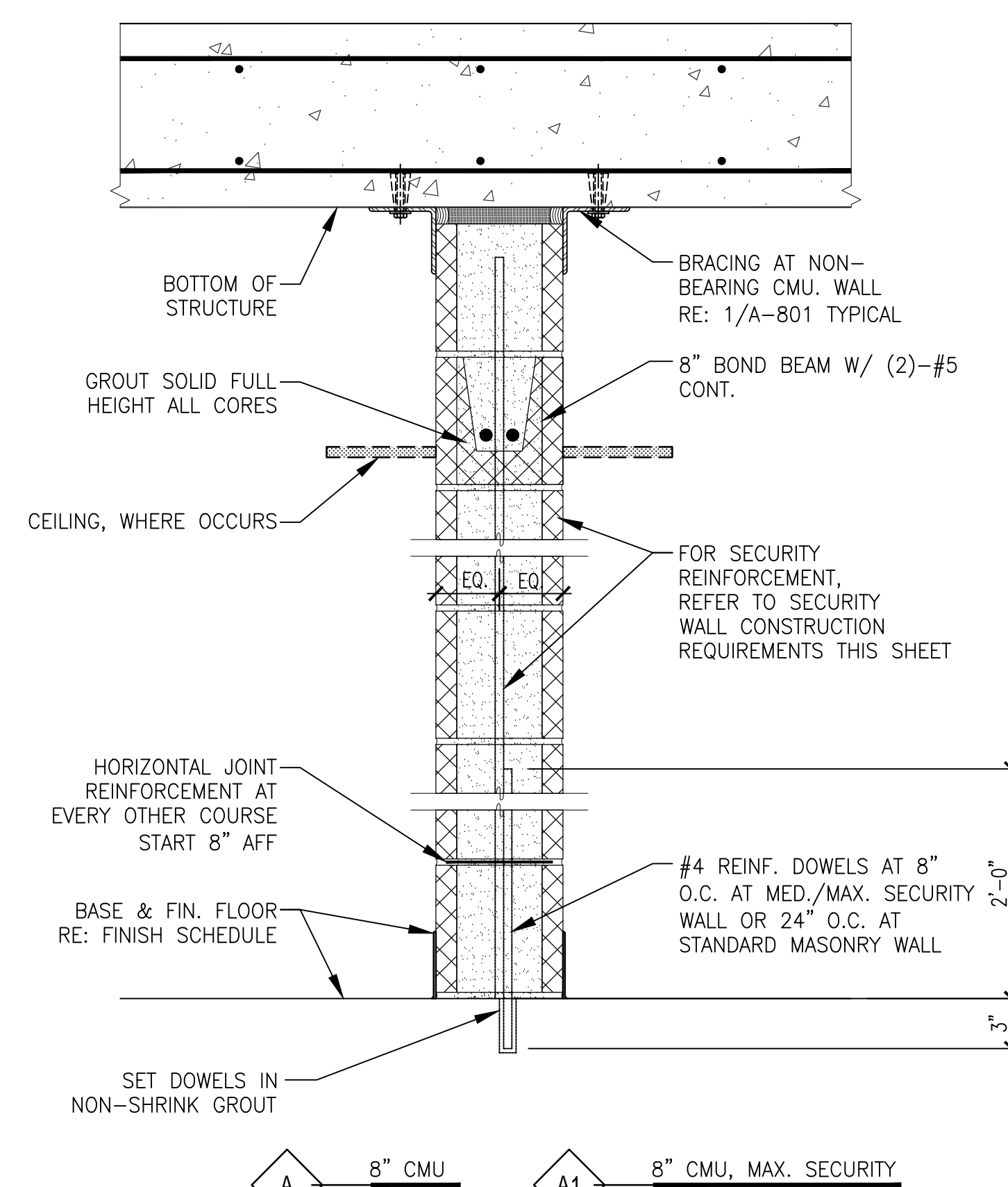
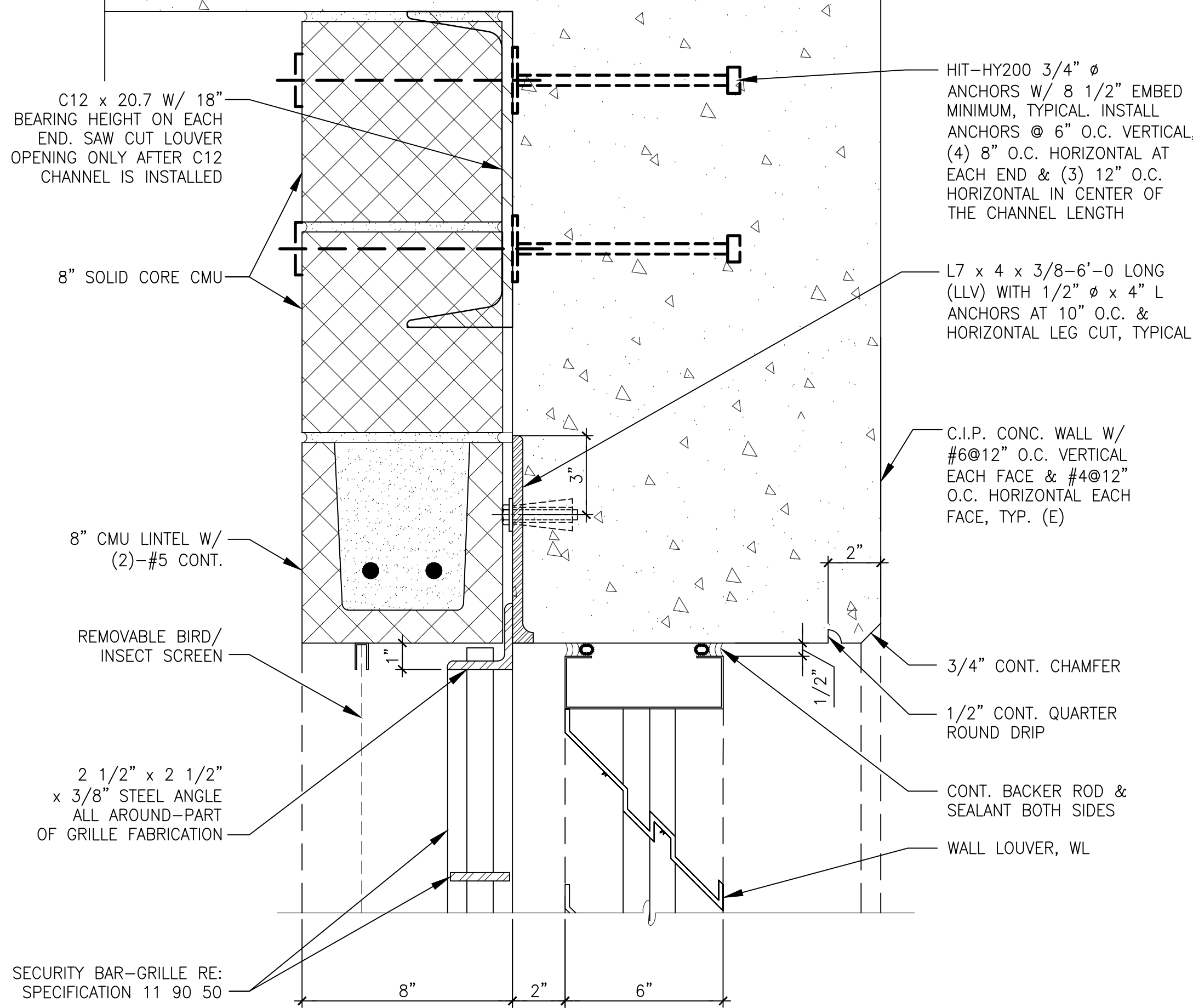

A 8" CMU **A1 8" CMU, MAX. SECURITY**

100% CONSTRUCTION DOCUMENTS

DESIGNED: CCJM					
DRAWN: CCJM					
CHECKED: CCJM					
	REVISION	DATE	DESCRIPTION	BY	APP.
PROJECT DRAWINGS					
CERTIFICATION			DETAILS I		ARCH
I HEREBY CERTIFY THAT THESE DOCUMENTS WERE PREPARED OR APPROVED BY ME AND THAT I AM A DULY LICENSED ARCHITECT / PROFESSIONAL ENGINEER UNDER THE LAWS OF THE DISTRICT OF COLUMBIA			MAINTENANCE SHOP HVAC & LAUNDRY ROOM ALTERATIONS CENTRAL DETENTION FACILITY (D.C. JAIL) DEPARTMENT OF CORRECTIONS DISTRICT OF COLUMBIA		DRAWING NO. A-801
REGISTRATION NO. _____			CCJM C.C. Johnson & Malhotra, P.C.		BUILDING ID NO.: 299
EXP. DATE: _____			1025 Connecticut Ave., N.W., Suite 1017 Washington, DC 20036		PROJECT NO.: CR-104C
ARCHITECT/ENGINEER			GOVERNMENT OF THE DISTRICT OF COLUMBIA DEPARTMENT OF GENERAL SERVICES		DATE: APR 6, 2016
EXP. DATE: 04/30/2016					SHEET: 5 OF 16

C.C. Johnson & Malhotra, P.C. 1025 Connecticut Ave., N.W., Suite 1017, Washington, DC 20036
 Project: Maintenance Shop HVAC & Laundry Room Alterations, Central Detention Facility (D.C. Jail), Department of Corrections, District of Columbia
 Drawing No.: A-801

DOOR SCHEDULE																			
MARK OPENING / DOOR NO.	ROOM NAME	DOOR								FRAME								REMARKS	
		SINGLE	PAIR	TYPE	WIDTH	HEIGHT	THICK.	MATL.	GLASS TYPE	TYPE	THICK.	MATL.	HEAD DETAIL	JAMB (S) DETAIL	JAMB (H) DETAIL	SILL DETAIL	HARDWARE NUMBER		RATING IN MINUTES
B100A	SORTING & FOLDING AREA B100	X		--	3'-0"	7'-0"		WIRE MESH	-	-	-	SS	---	---	---	---	SH-4	---	NEW SS WIRE MESH GATE
B102	CLEAN LINEN STORAGE B102		X	A	4'-0"	8'-0"	1-3/4"	HM	-	1	5-5/8"	HM	2/A801	3/A801	---	---	SH-4A	45 MIN.	NEW
B110	LOADING DOCK B110			EXIST	3'-0"	7'-0"		GDHM	EXIST		EXIST	GDHM	---	---	---	---	EXIST		EXISTING TO REMAIN
B110A	LOADING DOCK B110			EXIST	6'-0"	9'-4"		STEEL	-		EXIST	STEEL	---	---	---	---	EXIST		EXISTING TO REMAIN
B110B	LOADING DOCK B110			EXIST	9'-4"	9'-4"		STEEL	-		EXIST	STEEL	---	---	---	---	EXIST		EXISTING TO REMAIN
B110C	LOADING DOCK B110			EXIST	9'-4"	9'-4"		STEEL	-		EXIST	STEEL	---	---	---	---	EXIST		EXISTING TO REMAIN
B110D	LOADING DOCK B110			EXIST	9'-4"	9'-4"		STEEL	-		EXIST	STEEL	---	---	---	---	EXIST		EXISTING TO REMAIN
B102A	CLEAN LINEN STORAGE B102		X	A	4'-0"	8'-0"	2"	DHM	-	1	5-5/8"	DHM	2/A801	3/A801	---	---	SH-4B	45 MIN.	NEW

FINISH SCHEDULE				
DESIGNATION	TYPE / LOCATION	FINISH	COLOR	NOTES
CL-1	EXPOSED STRUCTURE	PTD	MATCH EXISTING	EXPOSED STRUCTURE CEILINGS AND ALL CEILING ITEMS TO BE PAINTED
CL-2	PERFORATED SECURITY ACOUSTIC PANEL	MANUFACTURER PTD FINISH	MATCH EXISTING	2'-0" x 2'-0" UON
CL-3	PERFORATED SECURITY ACOUSTIC METAL PLANK	MANUFACTURER PTD FINISH	MATCH EXISTING	1'-6" WIDTH UON
CL-4	NON-PERFORATED SS SECURITY PLANK	STAINLESS STEEL	MATCH EXISTING	1'-6" WIDTH UON
	FLOOR	RESINOUS	MATCH EXISTING	ALL FLOORS TO RECEIVE THIS FINISH
	BASE	RESINOUS	MATCH EXISTING	4" BASE TYPICAL, UON.
	INTERIOR CMU WALL	PTD	MATCH EXISTING	
	METAL WALL PANEL	MANUFACTURER PTD FINISH	TBD	SEAMLESS FINISH IN WET AREAS
	DOOR	PTD	MATCH EXISTING	
	DOOR FRAME	PTD	MATCH EXISTING	TO MATCH DOOR COLOR
	STOREFRONT	MANUFACTURER FINISH	MATCH EXISTING	FINISH TO MATH OTHER WINDOW FRAMES ON THE EXISTING BUILDING
	EXTERIOR CMU/CONCRETE	PTD	MATCH EXISTING	

LEGEND:	
PTD = PAINTED	UON = UNLESS OTHERWISE NOTED
TBD = TO BE DETERMINED OR ARCHITECT TO SELECT COLOR	MFR = MANUFACTURER
MTL = METAL	FIN. = FINISH
SS = STAINLESS STEEL	

CMU LINTEL SCHEDULE			
CLEAR SPAN	WIDTH	DEPTH	REINF.
< 6'-0"	6"	8"	1-#5
< 6'-0"	8"	8"	2-#5
6'-1" - 7'-1"	8"	8"	2-#6
7'-1" - 10'-0"	8"	16"	2-#6
< 6'-0"	12"	8"	2-#5
6'-1" - 7'-1"	12"	8"	2-#7
7'-1" - 10'-0"	12"	16"	2-#7
10'-1" - 12'-0"	12"	24"	2-#7

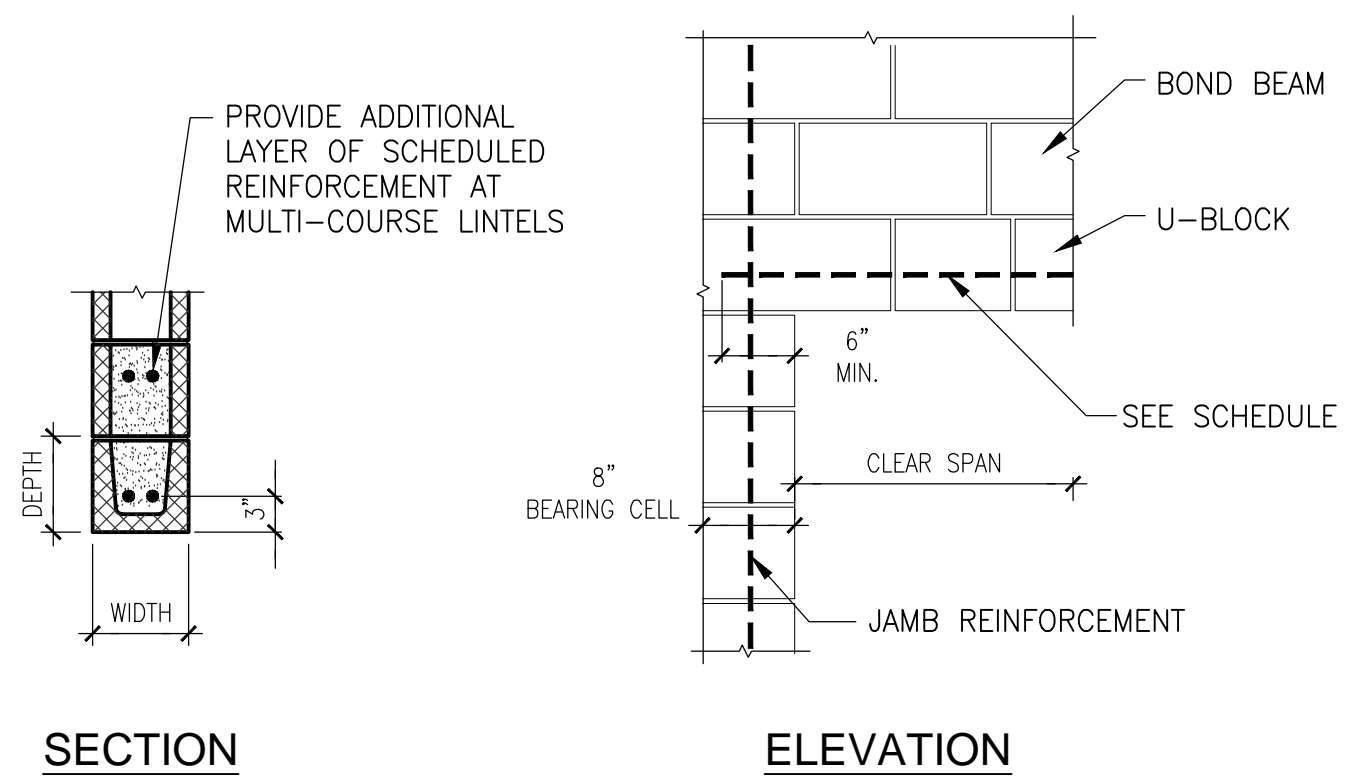

- STEEL LINTEL NOTES:**
- IN LIEU OF CONCRETE BLOCK LINTELS, PROVIDE W8x24S LINTELS AT DOOR OPENING AND (2) L4x3-1/2"x5/16" (LLV) STEEL ANGLE LINTELS FOR MASONRY OPENING LESS THAN 4'-0" WIDTH IN 8" CMU INTERIOR NON-LOAD BEARING WALLS/PARTITIONS.
 - FOR EXISTING DOOR OPENING ENLARGEMENT, REMOVE WALLS ON TOP OF IT. REMOVE THE EXISTING LINTEL. SAW CUT THE NEW OPENING EDGE. GROUT SOLID THE LINTEL SUPPORT. MINIMUM BEARING LENGTH SHALL BE 8" WITH ONE 1/2" ANCHOR (8" EMBEDMENT) SECURING THE LINTEL TO THE WALL AT EACH END. AFTER THE LINTEL IS INSTALLED, RECONSTRUCT THE WALL ON TOP OF THE LINTEL TO THE CEILING. THE WALL CONSTRUCTION SHALL MATCH EXISTING WALL CONSTRUCTION. WELD REBAR COUPLER ON TOP OF LINTELS AND ANCHOR THREADED VERTICAL REBARS ON TOP OF THE LINTEL.
 - FOR NEW OPENINGS ON THE WALL, FIRST REMOVE THE WALL ON TOP OF PLANNED OPENING, THEN SAW CUT THE DOOR OPENING. GROUT SOLID THE LINTEL SUPPORT. MINIMUM BEARING LENGTH SHALL BE 8" WITH ONE 1/2" ANCHOR (8" EMBEDMENT) SECURING THE LINTEL TO THE WALL AT EACH END. AFTER THE LINTEL IS INSTALLED, RECONSTRUCT THE WALL ON TOP OF THE LINTEL TO THE CEILING. THE WALL CONSTRUCTION SHALL MATCH EXISTING WALL CONSTRUCTION. WELD REBAR COUPLER ON TOP OF LINTELS AND ANCHOR THREADED VERTICAL REBARS ON TOP OF THE LINTEL.
 - USE MIN. 2500 PSI GROUT IN LINTEL BLOCK.
 - UNLESS OTHERWISE NOTED, PROVIDE LOOSE ANGLE LINTELS OVER ALL OPENINGS IN MASONRY WALLS AND PARTITIONS INCLUDING OPENINGS AT LOUVERS, RECESSES, DUCTS, VENTS, ETC. ALL LOOSE ANGLE LINTELS SHALL HAVE A MIN. BEARING OF 6" ON MASONRY.
 - FOR NEW OR ENLARGED OPENINGS IN EXISTING WALLS: CONTRACTOR SHALL PROVIDE ADEQUATE NEEDLE BEAMS, SHORING, ETC. AS REQUIRED FOR TEMPORARY SUPPORT OF WALLS DURING CONSTRUCTION. AT EXTERIOR WALLS, NEEDLE BEAMS AND LINTELS SHALL BE INSTALLED WITH MINIMAL DISTURBANCE TO EXISTING FACE MASONRY. ANY MASONRY DISTURBED DURING CONSTRUCTION SHALL BE RE-INSTALLED OR REPLACED TO MATCH EXISTING CONSTRUCTION. PROVIDE BEARING CONDITIONS AS NOTED ABOVE.

MASONRY REINFORCEMENT SCHEDULE		
12" CMU INTERIOR	Hw 20'-0"	#6@48" CTR'D.
8" CMU INTERIOR	Hw 20'-0"	#5@48" CTR'D.

1 NON-LOAD BEARING LINTEL SCHEDULE
SCALE: 3/4" = 1'-0"

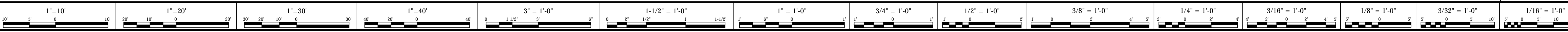

5



1



6



2

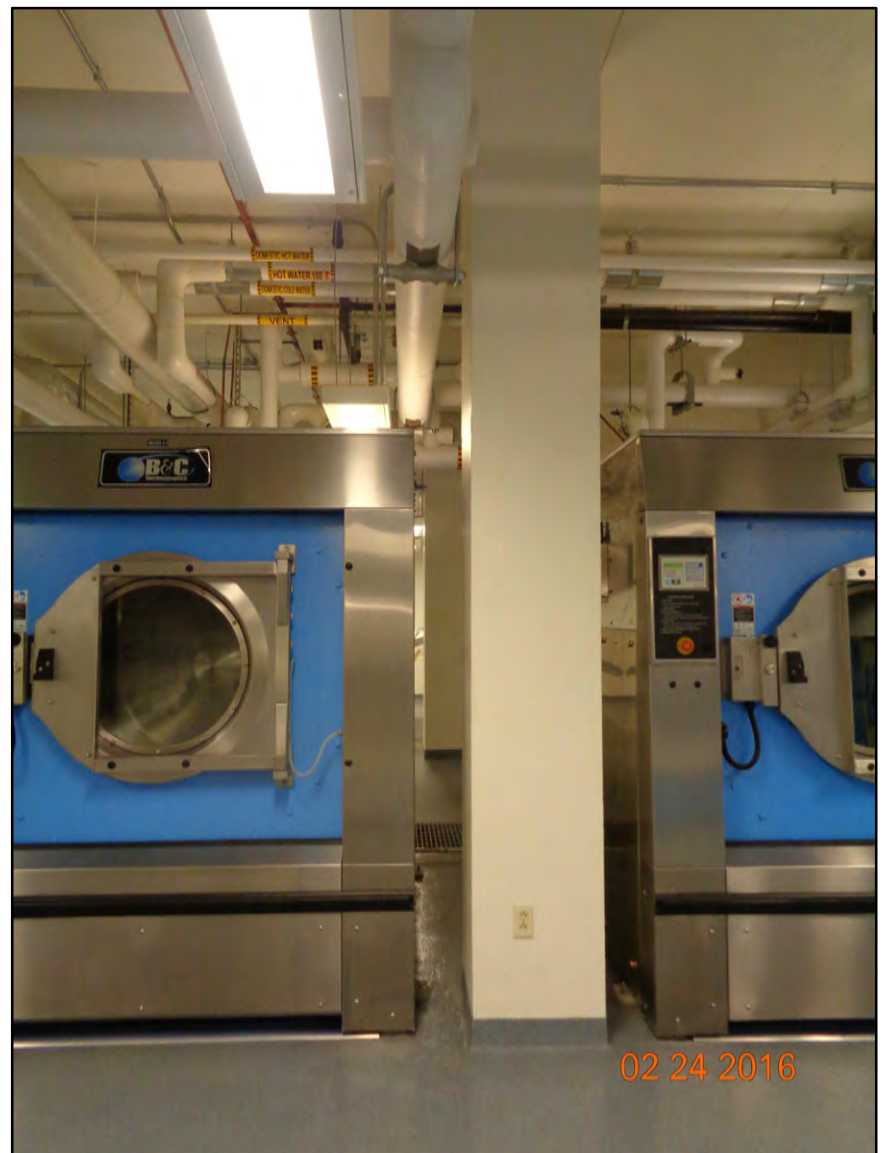

3



4

100% CONSTRUCTION DOCUMENTS

DESIGNED: CCJM				
DRAWN: CCJM				
CHECKED: CCJM				
REVISION	DATE	DESCRIPTION	BY	APP.
PROJECT DRAWINGS				
CERTIFICATION		DETAILS II		ARCH
I HEREBY CERTIFY THAT THESE DOCUMENTS WERE PREPARED OR APPROVED BY ME, AND THAT I AM A DULY LICENSED ARCHITECT / PROFESSIONAL ENGINEER UNDER THE LAWS OF THE DISTRICT OF COLUMBIA		MAINTENANCE SHOP HVAC & LAUNDRY ROOM ALTERATIONS CENTRAL DETENTION FACILITY (D.C. JAIL) DEPARTMENT OF CORRECTIONS DISTRICT OF COLUMBIA		DRAWING NO. A-802
REGISTRATION NO. AR-102102		CCJM C.C. Johnson & Malhotra, P.C. 1025 Connecticut Ave. N.W., Suite 1017 Washington, DC 20036		BUILDING ID NO.: 299
ARCHITECT/ENGINEER		GOVERNMENT OF THE DISTRICT OF COLUMBIA DEPARTMENT OF GENERAL SERVICES		PROJECT NO.: CR-104C
EXP. DATE: 04/30/2016				DATE: APR 6, 2016
				SHEET: 6 OF 16

C.C. Johnson & Malhotra, P.C. East River by UHart Plac. Date: 4/17/2016 11:44:00 AM File Scale: 1/8" = 1'-0" Project: MAINTENANCE SHOP HVAC & LAUNDRY ROOM ALTERATIONS CENTRAL DETENTION FACILITY (D.C. JAIL) DEPARTMENT OF CORRECTIONS DISTRICT OF COLUMBIA
 File Name: C:\Users\ccj\Documents\CDM\Projects\141807_001_CD_MaintShopHVAC\Drawings\141807_001_CD_MaintShopHVAC_Sheet_A-802.dwg
 Plot Date: 4/17/2016 11:44:00 AM Plot Scale: 1/8" = 1'-0" Plot Sheet: A-802

SYMBOLS	
	COMBINATION BALANCING AND MEASURING VALVE (CIRCUIT SETTER OR EQUIVALENT)
	PRESSURE REDUCING VALVE
	2-WAY CONTROL VALVE
	3-WAY CONTROL VALVE
	SHUT OFF VALVE
	SAFETY RELIEF VALVE
	GLOBE VALVE
	STRAINER
	STRAINER W/ BLOWOFF
	FLOW METER (VENTURI)
	STEAM TRAP
	PRESSURE GAUGE W/GAUGE COCK
	FLOW SWITCH
	PRESSURE SWITCH
	THERMOMETER W/WELL
	CAPPED PIPE
	PIPE ELBOW TURNED UP
	PIPE ELBOW TURNED DOWN
	DIRECTION OF FLOW
	PIPE UNION
	REFRIGERANT LIQUID
	REFRIGERANT GAS
	COMPRESSED AIR
	CONDENSER WATER SUPPLY
	CONDENSER WATER RETURN
	CONDENSATE DRAIN
	HOT WATER SUPPLY
	HOT WATER RETURN
	CHILLED WATER RETURN
	CHILLED WATER SUPPLY
	LOW PRESSURE STEAM
	LOW PRESSURE CONDENSATE RETURN
	HIGH PRESSURE CONDENSATE
	HIGH PRESSURE STEAM
	HIGH PRESSURE CONDENSATE RETURN
	MEDIUM PRESSURE STEAM
	PUMP RETURN
	VENT
	DISCONNECT FROM EXISTING
	CONNECT TO EXISTING
	PIPE ANCHOR
	PIPE GUIDE
	EXPANSION JOINT
	PIPE SUPPORT

SYMBOLS	
	EXISTING TO REMAIN
	EXISTING TO BE REMOVED
	NEW WORK
	TEMPERATURE SENSOR, 48" AFF
	THERMOSTAT, 48" AFF
	THERMOSTAT WITH CONTROL WIRES, 48" AFF
	HUMIDITY SENSOR, 48" AFF
	DIFFERENTIAL PRESSURE SENSOR, 60" AFF
	CO2 SENSOR 3'-0" ABOVE FINISHED FLOOR
	CO SENSOR 3'-0" ABOVE FINISHED FLOOR
	SUPPLY AIR DUCT/AIR DEVICE
	RETURN AIR DUCT/AIR DEVICE
	MANUAL AIR VOLUME DAMPER
	BACK DRAFT DAMPER
	MOTORIZED DAMPER
	SMOKE DAMPER
	COMBINATION FIRE/SMOKE DAMPER
	FIRE DAMPER
	SPLITTER DAMPER
	SMOKE DUCT DETECTOR
	DUCT SIZE, INCHES FIRST FIGURE IS SIDE SHOWN
	ROUND DUCT SIZE, INCHES
	DUCTWORK OR EQUIPMENT TO BE DEMOLISHED
	CHANGE OF ELEVATION (R)RISE (D)DROP
	SUPPLY DUCT TURNED DOWN
	SUPPLY DUCT TURNED UP
	RETURN DUCT TURNED DOWN
	DUCT WITH SOUND LINER, SIZES INDICATED INNER CLEAR DIMENSION.
	RETURN DUCT TURNED UP
	CEILING GRILLE OR CEILING REGISTER WITH VOLUME DAMPER
	DUCT BRANCH CONNECTION WITH VOLUME DAMPER (RECT. X RECT)
	DUCT BRANCH CONNECTION WITH VOLUME DAMPER AND FLEXIBLE DUCT CONNECTED TO SUPPLY DIFFUSER
	FLEXIBLE DUCT CONNECTION
	TRANSITION
	SQUARE TO ROUND TRANSITION
	ELBOW WITH TURNING VANES
	UNIT HEATER
	EXHAUST FAN
	CENTRIFUGAL FAN
	BRANCH SELECTOR BOX
	X: SECTION DESIGNATION LETTER
	X-#: DETAIL DESIGNATION DRAWING
	X: DETAIL DESIGNATION NUMBER
	X-#: DETAIL DESIGNATION DRAWING
	KEY NOTE NUMBER DESIGNATION
	X: DETAIL/PICTURE DESIGNATION NUMBER
	AAA: DETAIL/PICTURE DESIGNATION DRAWING
	EQUIPMENT TAG
	CAPACITY

ABBREVIATIONS	
A	AMPERE
AD	ACCESS DOOR
AFF	ABOVE FINISHED FLOOR
AFG	ABOVE FINISHED GRADE
ANSI	AMERICAN NATIONAL STANDARDS INSTITUTE
APPROX	APPROXIMATELY
ARI	AMERICAN REFRIGERATION INSTITUTE
BD	BACKDRAFT DAMPER
BE	BOTTOM ELEVATION
BHP	BRAKE HORSEPOWER
BTUH	BRITISH THERMAL UNITS PER HOUR
BS	BRANCH SELECTOR BOX
CFM	CUBIC FEET PER MINUTE
CO	CARBON MONOXIDE
CU	CONDENSING UNIT
DAC	DOOR AIR CURTAIN
DB	DRY BULB
DN	DOWN
DWG	DRAWING
DX	DIRECT EXPANSION
EA	EXHAUST AIR
EAT	ENTERING AIR TEMPERATURE
EER	ENERGY EFFICIENCY RATIO
EF	EXHAUST FAN
ESP	EXTERNAL STATIC PRESSURE
ERU	ENERGY RECOVERY UNIT
F	DEGREES FAHRENHEIT
F&T	FLOAT & THERMOSTATIC
FLA	FULL LOAD AMPERES
FT	FEET
HC	HEATING COIL
HP	HORSEPOWER
HPC	HIGH PRESSURE CONDENSATE
HPS	HIGH PRESSURE STEAM
HR	HOUR
HZ	HERTZ (CYCLES PER SECOND) INCHES
IN WG	INCHES WATER GAUGE
KW	KILOWATT
LAT	LEAVING AIR TEMPERATURE
LB	POUND
LRA	LOCKED ROTOR AMPERES
MBH	1000 BRITISH THERMAL UNITS PER HOUR
MD	MOTORIZED DAMPER
NC	NORMALLY CLOSED, NOISE CRITERIA
NO	NORMALLY OPEN
NTS	NOT TO SCALE
OA	OUTSIDE AIR
PH	PHASE
PLUM	PLUMBING
PRV	PRESSURE REDUCING VALVE
PSI	POUNDS PER SQUARE INCH
RA	RETURN AIR
RCP	REFLECTED CEILING PLAN
RG	REFRIGERANT GAS
RH	RELATIVE HUMIDITY
RL	REFRIGERANT LIQUID
RLA	RUNNING LOAD AMPERES
RF	RETURN FAN

GENERAL NOTES	
1.	SCOPE: FURNISH ALL LABOR, MATERIALS, TOOLS, EQUIPMENT, SERVICES AND SKILLED SUPERVISION NECESSARY TO PROVIDE, INSTALL, TEST AND ADJUST HVAC SYSTEMS COMPLETE, OPERATIONAL, AND READY FOR USE, AS INDICATED IN THESE DRAWINGS AND SPECIFICATIONS.
2.	PERMITS, LICENSES & FEES: PAY ALL REQUIRED FEES AND OBTAIN ALL NECESSARY PERMITS AND LICENSES FOR LEGAL REMOVAL AND INSTALLATION OF THE WORK.
3.	APPLICABLE CODES AND STANDARDS: PERFORM ALL WORK IN ACCORDANCE WITH THE FOLLOWING CODES AND STANDARDS AND ANY REGULATIONS EFFECTIVE IN THE PROJECT JURISDICTION. BRING ALL CODE CONFLICTS TO THE ATTENTION OF THE OWNER FOR RESOLUTION. APPLICABLE CODES AND STANDARDS ON THIS PROJECT INCLUDE, BUT ARE NOT LIMITED TO, THE FOLLOWING: A. INTERNATIONAL BUILDING CODE 2012 B. INTERNATIONAL MECHANICAL CODE 2012 C. INTERNATIONAL PLUMBING CODE 2012 D. INTERNATIONAL ENERGY CONSERVATION CODE, 2012 E. NFPA 70, NATIONAL ELECTRICAL CODE 2011 F. DCMR, DC CONSTRUCTION CODE SUPPLEMENT 2013
4.	DRAWING ACCURACY: LOCATIONS AND SIZES OF EXISTING EQUIPMENT, PIPING, DUCTWORK, OUTLETS, FIXTURES, AND DEVICES SHOWN ON DRAWINGS ARE APPROXIMATE. VERIFY AT THE PROJECT SITE. DRAWINGS ARE DIAGRAMMATIC AND NOT INTENDED TO BE SCALED. WHEN INDICATED, LOCATE ALL WORK IN ACCORDANCE WITH ANNOTATED DIMENSIONS ON ARCHITECTURAL PLANS, ELEVATIONS AND DETAILS.
5.	SITE VISIT: VISIT THE SITE AND BECOME FAMILIAR WITH THE EXISTING CONDITIONS, EQUIPMENT, DUCTWORK, PIPING, WIRING, CONSTRUCTION, FINISHES, AND STRUCTURE PRIOR TO START OF WORK. WHEN ANY DISCREPANCY OR CONFLICT IS DETECTED AT THE PROJECT SITE, NOTIFY THE COTR IMMEDIATELY PRIOR TO COMMENCING WORK.
6.	COORDINATION: COORDINATE AND SEQUENCE THE WORK OF ALL DIVISIONS AND TRADES PRIOR TO FABRICATION AND INSTALLATION OF DUCTWORK AND RACEWAYS. COORDINATE THE LOCATION OF ALL NEW EQUIPMENT, DUCTWORK, AND DEVICES WITH NEW STRUCTURE AND EQUIPMENT BEFORE FABRICATION. MAKE NECESSARY ACCOMMODATIONS TO MEET THE INTENT OF THE DRAWINGS AND ENSURE A COORDINATED INSTALLATION.
7.	MATERIALS: MANUFACTURERS AND CATALOG NUMBERS ARE USED HERE STRICTLY AS A REFERENCE, THEY REPRESENT THE TYPE, SIZE, CONSTRUCTION, PERFORMANCE, AND LEVEL OF QUALITY DESIRED. EQUIPMENT FROM OTHER MANUFACTURERS THAT MATCH OR SURPASS THE CHARACTERISTICS OF THOSE REFERENCED WILL BE ACCEPTABLE SUBJECT TO APPROVAL BY THE OWNERS REPRESENTATIVE.
8.	SUBMITTALS AND SUBSTITUTIONS: PROVIDE PRODUCT INFORMATION, SHOP DRAWINGS, AND WARRANTIES FOR MATERIALS AND SERVICES TO THE OWNER FOR APPROVAL. NO SUBSTITUTION WILL BE ALLOWED WITHOUT PERMISSION OF THE COTR IN WRITING.
9.	INSTALLATION OF NEW WORK: INSTALL EQUIPMENT, DUCTWORK, PIPING, FIXTURES, ETC. IN NEAT AND WORKMANLIKE MANNER, AND CONFORMING TO THE LATEST TRADE PRACTICES. COORDINATE DUCTWORK AND PIPING WITH THE WORK OF OTHER TRADES PRIOR TO FABRICATION. MAKE NECESSARY ACCOMMODATIONS TO MEET THE INTENT OF THE DRAWINGS AND ENSURE A COORDINATED INSTALLATION.
10.	DRAWINGS ARE DIAGRAMMATIC AND REPRESENT THE INTENT OF THE CONTRACT. DESIGN DRAWINGS ARE NOT TO BE CONSIDERED AS SUBSTITUTION TO SHOP DRAWINGS. FOLLOW DRAWINGS AS CLOSELY AS CONDITIONS ALLOW TO COMPLETE THE INTENT OF THE CONTRACT. THE RIGHT IS RESERVED BY THE ENGINEER TO MAKE MINOR CHANGES IN LOCATIONS AND ARRANGEMENTS WHEN REQUIRED BY JOB DEVELOPMENT WITHOUT ADDITIONAL COMPENSATION TO THE CONTRACTOR.
11.	MOUNTING HEIGHTS: COORDINATE MOUNTING HEIGHTS OF DEVICES ON FINISHED WALLS TO PROVIDE A NEAT AND SYMMETRICAL APPEARANCE.
12.	CLEANING & MATERIAL DISPOSITION: CLEAR ALL DEBRIS FROM THE AREA OF WORK AND LEAVE SITE IN CLEAN CONDITION. CLEAN ALL EQUIPMENT ENCLOSURES, INSIDE AND OUTSIDE. REMOVE ALL DEMOLISHED EQUIPMENT AND DEBRIS, NOT TO BE REUSED OR SALVAGED, FROM THE SITE AND PROPERLY DISPOSE OF IN ACCORDANCE WITH APPLICABLE REGULATIONS.

SHEET LIST	
SHEET NO.	SHEET NAME
M-001	MECHANICAL NOTES, ABBREVIATIONS AND LEGEND
M-101	ADMINISTRATION MODULE - BASEMENT LEVEL PART PLAN - DUCTWORK
M-201	ADMINISTRATION MODULE - BASEMENT LEVEL PART PLAN - PIPING
M-501	DETAILS I
M-502	DETAILS II
M-503	DETAILS III
M-504	DETAILS IV
M-601	HVAC SCHEDULES

C.C. Johnson & Malhotra, P.C. 1025 Connecticut Ave., N.W., Suite 1017 Washington, DC 20036
 File Name: C:\Users\jmalhotra\Documents\2016\Projects\111027-001 DC Jail Laundry, HVAC, DUCTWORK, PIPING, ELECTRICAL, MECHANICAL, MOUNTING HEIGHTS, SHOWN SHEET: M-001

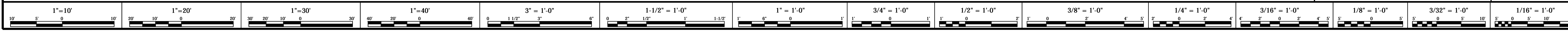

5101 Wisconsin Avenue, N.W., Suite 403
 Washington, DC 20016-4140
 Tel: (202) 362-5001 Fax: (202) 362-5561

PROFESSIONAL STAMP:

100% CONSTRUCTION DOCUMENTS					
DESIGNED: DAK					
DRAWN: MCB					
CHECKED: DAK					
	REVISION	DATE	DESCRIPTION	BY	APP.
PROJECT DRAWINGS					
CERTIFICATION			MECHANICAL NOTES, ABBREVIATIONS AND LEGEND		HVAC
I HEREBY CERTIFY THAT THESE DOCUMENTS WERE PREPARED OR APPROVED BY ME, AND THAT I AM A DULY LICENSED ARCHITECT / PROFESSIONAL ENGINEER UNDER THE LAWS OF THE DISTRICT OF COLUMBIA			MAINTENANCE SHOP HVAC & LAUNDRY ROOM ALTERATIONS CENTRAL DETENTION FACILITY (D.C. JAIL) DEPARTMENT OF CORRECTIONS DISTRICT OF COLUMBIA		DRAWING NO. M-001
REGISTRATION NO. 7852			CCJM C.C. Johnson & Malhotra, P.C. 1025 Connecticut Ave., N.W., Suite 1017 Washington, DC 20036		BUILDING ID NO.: 299
EXP. DATE: 08-31-2016			ARCHITECT/ENGINEER		PROJECT NO.: CR-104C
			GOVERNMENT OF THE DISTRICT OF COLUMBIA DEPARTMENT OF GENERAL SERVICES		DATE: APR 6, 2016
					SHEET: 7 OF 16

- NOTES:**
- PROVIDE ADDITIONAL 2" INSULATION ON STEAM PIPING, CONDENSATE PIPING, CONDENSATE TANK AND FLASH TANK.
 - REMOVE EXISTING CLEVIS HANGER AND PROVIDE NEW CLEVIS HANGER OF A SIZE APPROPRIATE FOR THE PIPE WITH THE ADDITIONAL INSULATION THICKNESS AND INSULATION SHIELD. PIPE ROLLER HANGERS TO BE REUSED.
 - REMOVE AND RELOCATE PRESSURE REDUCING STATION, 100 TO 75 PSI. JOHNSON CONTROLS TO PROVIDE AND INSTALL NEW CONTROL VALVE. SEE DETAILS 2, 3 THIS SHEET FOR ADDITIONAL INFORMATION. REMOVE PIPING AT LOCATIONS INDICATED.
 - NOT USED.
 - PROVIDE FLEXIBLE FABRIC COVERED INSULATION BLANKETS ON VALVES, STRAINERS, ANCHORS, AND PIPE GUIDES. FLEXIBLE FABRIC TO BE:
 - MAXIMUM SERVICE TEMPERATURE: 550°F
 - PRODUCT COMPONENTS: OUTER JACKET 3/4" OZ./SQ. YD. SILICONE IMPREGNATED FIBERGLASS CLOTH. INNER JACKET, 17.7 OZ./SQ. YD. PLAIN FIBERGLASS FABRIC WITH AN OUTSIDE LAYER OF STAINLESS STEEL TYPE 304 KNITTED WIRE MESH (0.011" DIAMETER @ 16 SF/LB.) INSULATION MATERIAL IS AN 11PFC FIBERGLASS NEEDED MAT - TYPE "E" FIBER. IS ENCAPSULATED BY THE SILICONE CLOTH, KNITTED MESH AND PLAIN FIBERGLASS CLOTH SEWN TOGETHER, PRODUCING A SELF CONTAINED BLANKET SYSTEM. THE BLANKET SYSTEM INCLUDES FASTENERS FOR EASY INSTALLATION AND REMOVAL.
 - BLANKET CONSTRUCTION - BLANKET CONSTRUCTION SHALL BE SINGLE SEWN LOCK STITCH WITH MINIMUM 7 STITCHES PER INCH. ALL RAW JACKET EDGES WILL HAVE TRI-FOLD SILICONE FIBERGLASS CLOTH BINDING. NO RAW CUT JACKET EDGE WILL BE EXPOSED. STITCHING WILL BE DONE WITH A STAINLESS STEEL THREAD. MONEL STAPLES SHALL FOLLOW THE OUTER JACKET EDGE FOR REINFORCEMENT AND BE SPACED NO GREATER THAN 1 INCH.
 - STANDARD FASTENER (WIRE TWISTS) - A 21 GAUGE TYPE 304 STAINLESS STEEL WIRE WILL BE DOUBLED UP AND TWISTED IN A SPIRAL FASHION, WITH A MINIMUM OF 4 TO 5 TWISTS PER INCH. WIRE TWIST LENGTH WILL BE 16" OR LONGER. THE WIRE TWIST WILL BE SECURED TO THE LACING PIN AT THE PIN STEM. LACING PIN STEMS WILL BE 1/4" GAUGE TYPE 304 STAINLESS STEEL. PINS WILL BE HELD IN PLACE WITH 1" DIAMETER TYPE 304 STAINLESS STEEL SPEED WASHERS. WIRE TWIST WILL BE SPACED 6" ON CENTER ALONG CLOSING SEAMS WITH MATCHING LACING PINS TO LACE AND SECURE TO.
 - SCRAP LOOSE & PEELING PAINT AND PROVIDE ONE PRIMER COAT PRIOR TO APPLYING NEW INSULATION. PROVIDE 4" FOIL FACED BOARD INSULATION TO TUNNEL WALL AND CEILING WHERE INDICATED. INSULATION SHALL BE TYPE I-1 OR I-2 PER SPECIFICATION SECTION 072100.
 - EXTEND NEW 1/2" CA HOSE FROM EXISTING 1/2" CA DROP LOCATED ON COLUMN 11/EE. EXTEND HOSE UNDER UNIT, TO WEST SIDE OF RE-LOCATED FOLDER. NEW HOSE SHALL MATCH EXISTING. CONNECT TO UNIT QUICK DISCONNECT. SECURE HOSE TO FOLDER FRAME. SEE DETAIL 3/4-201 FOR ADDITIONAL INFORMATION.
 - PRIORITY CONTROL VALVE SHALL BE SIZED, SPECIFIED, AND PROVIDED BY JOHNSON CONTROLS, INC.

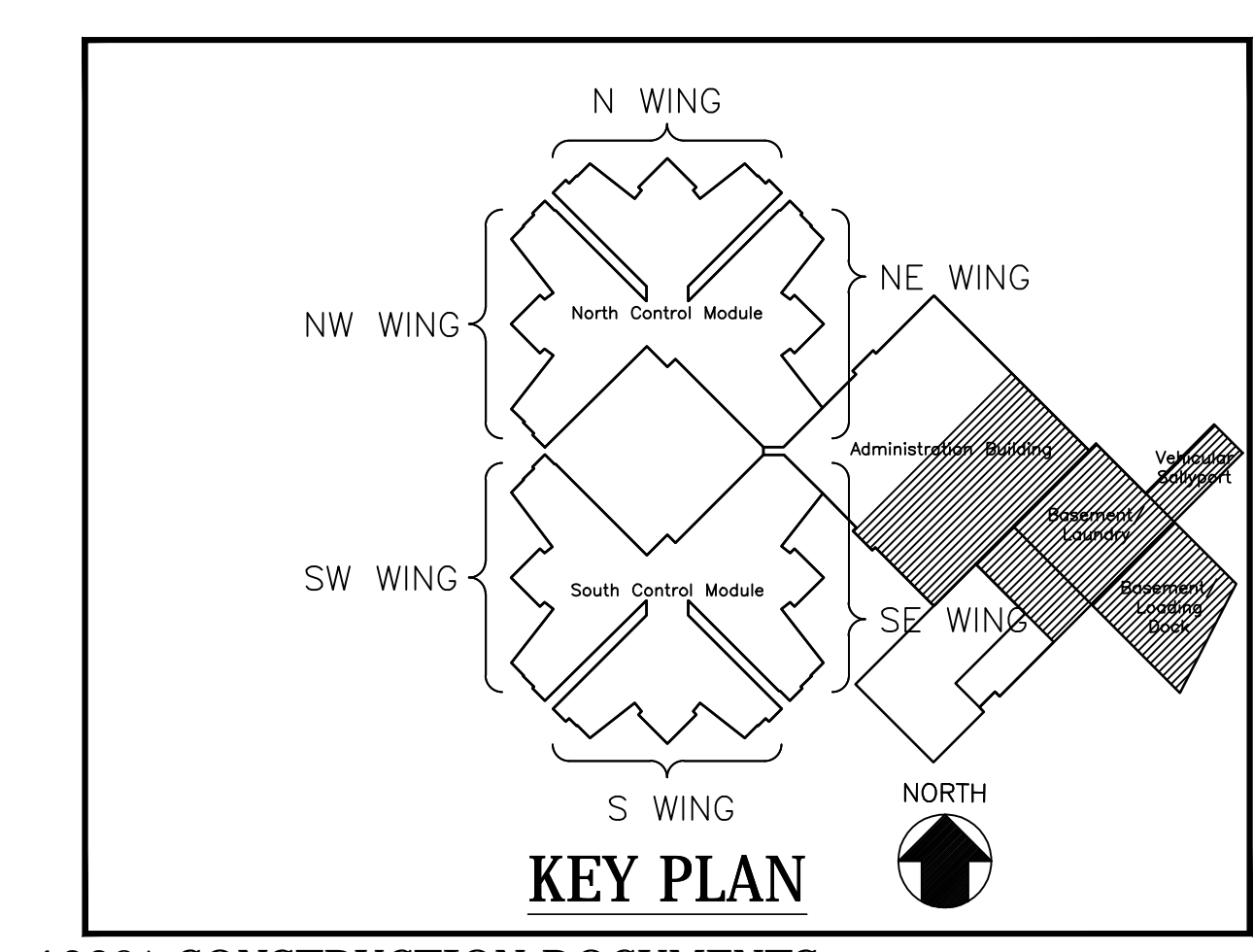
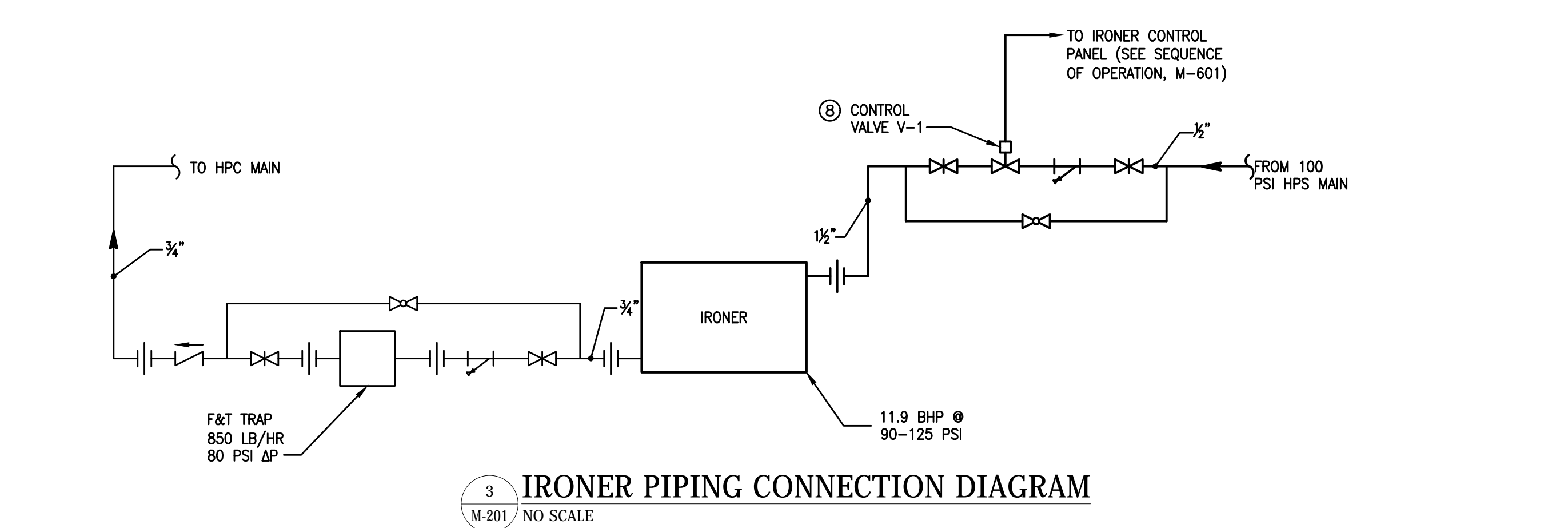
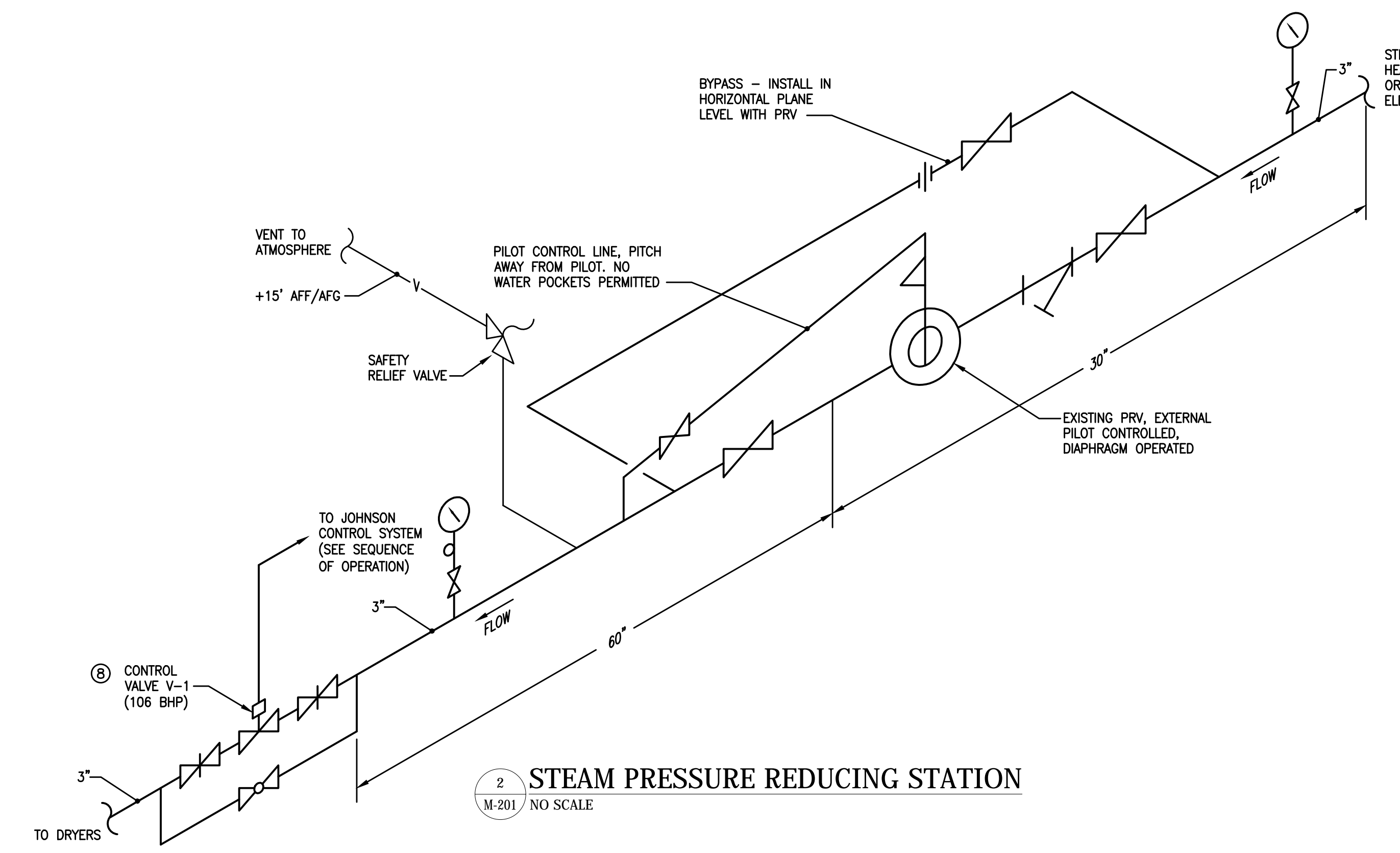
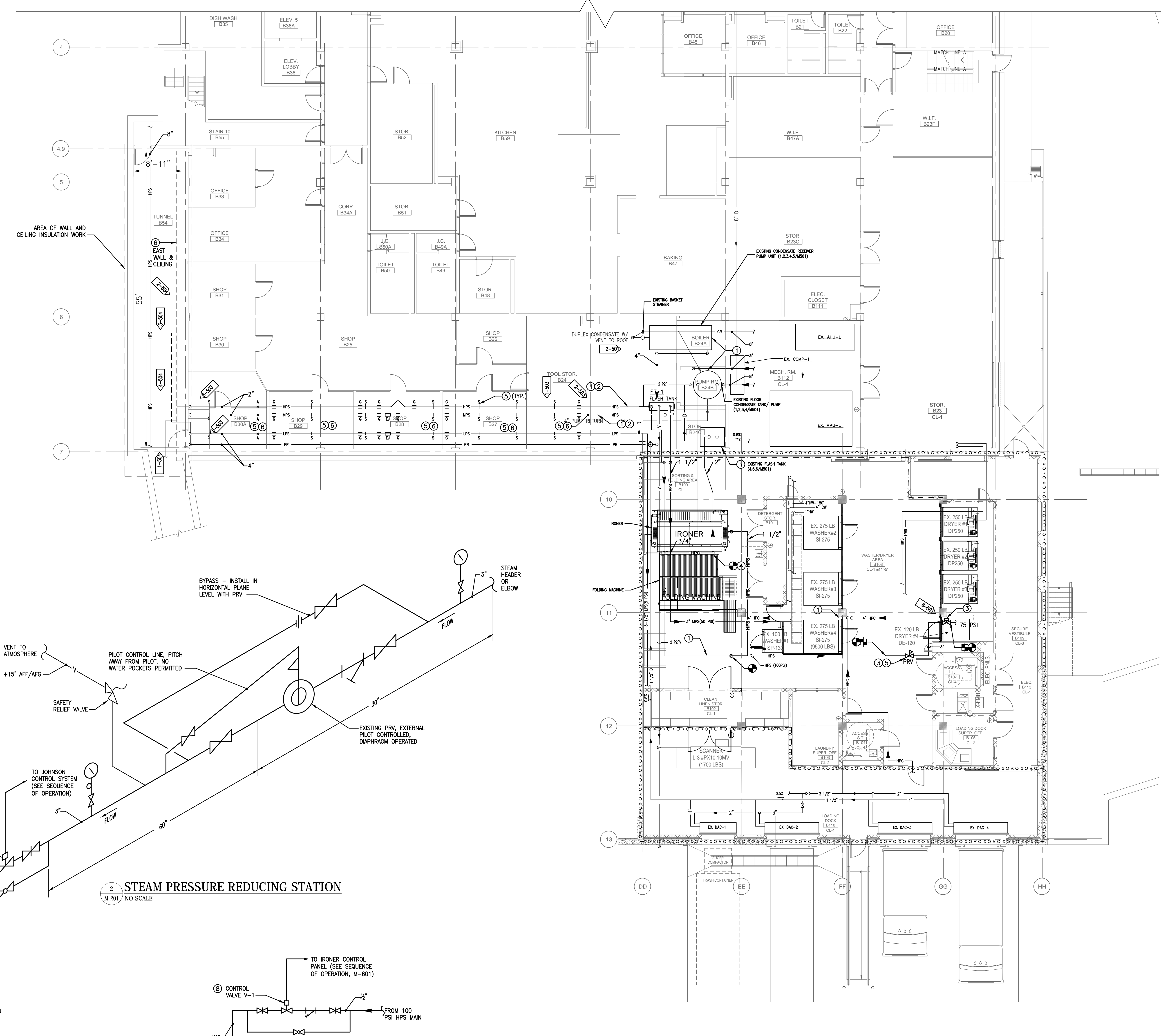

1 BASEMENT LEVEL PART PLAN - PIPING
M-201 SCALE: 1/8"=1'-0"

100% CONSTRUCTION DOCUMENTS

DESIGNED: DAK					
DRAWN: MCB					
CHECKED: DAK					
	REVISION	DATE	DESCRIPTION	BY	APP.
CERTIFICATION			PROJECT DRAWINGS		
I HEREBY CERTIFY THAT THESE DOCUMENTS WERE PREPARED OR APPROVED BY ME, AND THAT I AM A DULY LICENSED ARCHITECT / PROFESSIONAL ENGINEER UNDER THE LAWS OF THE DISTRICT OF COLUMBIA			ADMINISTRATION MODULE - BASEMENT LEVEL PART PLAN - PIPING		
REGISTRATION NO. 7852			HVAC		
EXP. DATE: 08-31-2016			DRAWING NO. M-201		
ARCHITECT/ENGINEER			PROJECT NO.: CR-104C		
JVP Engineers, P.C. Consulting Engineers			DATE: APR 6, 2016		
5101 Wisconsin Avenue, N.W. Suite 403 Washington, DC 20016-4140 Tel: (202) 362-5503 Fax: (202) 362-5501			SHEET: 9 OF 16		
GOVERNMENT OF THE DISTRICT OF COLUMBIA DEPARTMENT OF GENERAL SERVICES			BUILDING ID NO.: 299		

C.C. Johnson & Malhotra, P.C. Architect/Engineer, 1100 17th St. N.W., Suite 403, Washington, DC 20036
 Project Name: Administration Building, Maintenance Shop & Laundry Room Alterations, Central Detention Facility (D.C. Jail), Department of Corrections, District of Columbia



1 OVERHEAD PIPING W/ PIPE GUIDE AND PIPE HANGER

M-503 NO SCALE
SEE NOTES 1 2 3 4

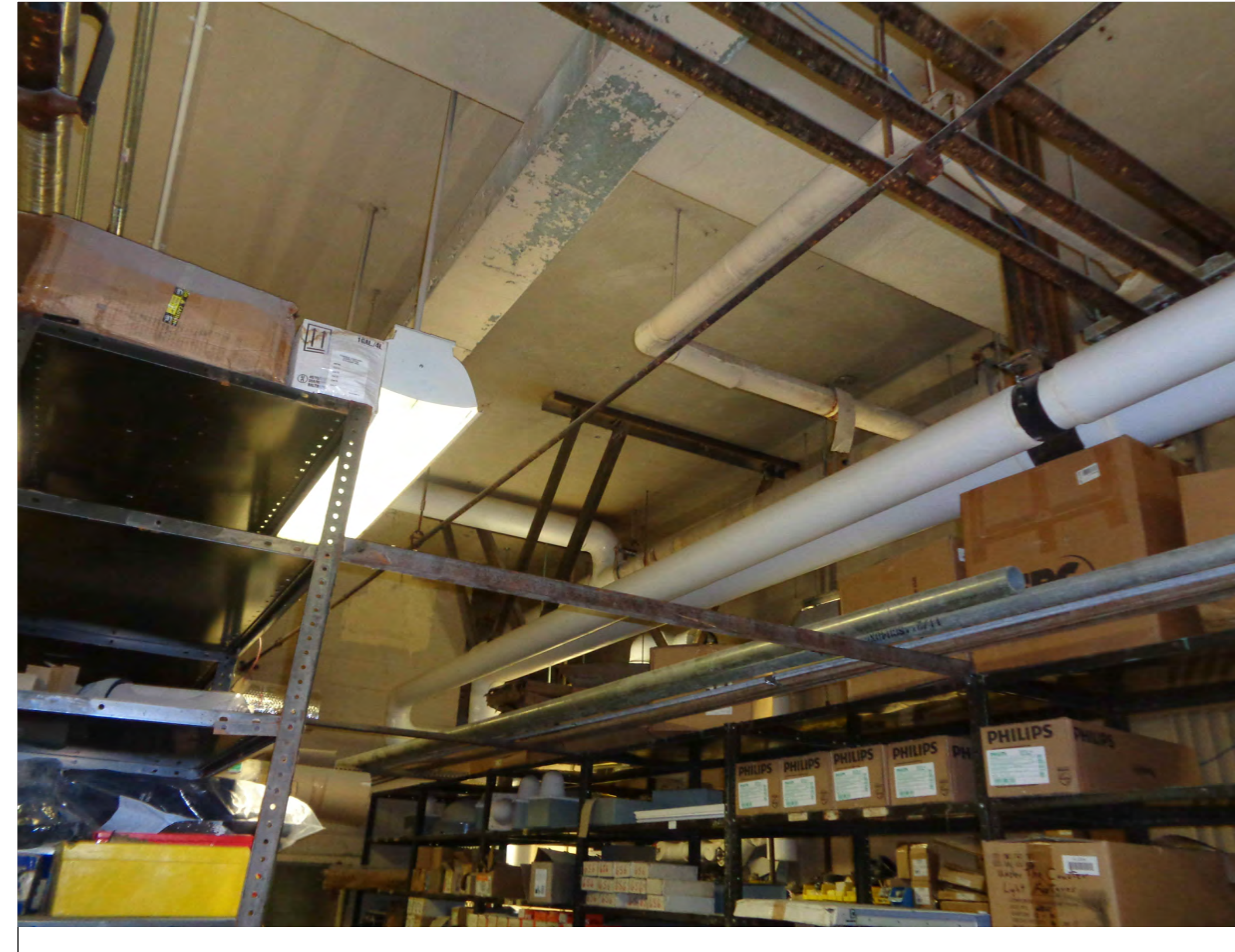

2 OVERHEAD PIPING W/ PIPE GUIDE AND PIPE ANCHOR

M-503 NO SCALE
SEE NOTES 1 2 3 4



3 CONDENSATE PIPING AT FLASH TANK

M-503 NO SCALE
SEE NOTES 1 2 3 4



4 DRIP LEG

M-503 NO SCALE
SEE NOTES 1 2 3 4



5 PIPING AT TUNNEL WALL

M-503 NO SCALE
SEE NOTES 1 2 3 4



6 PIPING AT TUNNEL WALL

M-503 NO SCALE
SEE NOTES 1 2 3 4



7 OVERHEAD PIPING

M-503 NO SCALE
SEE NOTES 1 2 3 4

- NOTE:
- 1 SCRAP LOOSE & PEELING PAINT AND PROVIDE ONE PRIMER COAT PRIOR TO APPLYING NEW INSULATION. PROVIDE 4" FOIL FACED BOARD INSULATION TO TUNNEL WALL AND CEILING WHERE INDICATED. INSULATION SHALL BE TYPE 1-1 OR 1-2 PER SPECIFICATION SECTION 072100.
 - 2 PROVIDE FLEXIBLE FABRIC COVERED INSULATION BLANKETS ON VALVES, STRAINERS, ANCHORS, AND PIPE GUIDES. FLEXIBLE FABRIC TO BE:
 - A. MAXIMUM SERVICE TEMPERATURE: 550F
 - B. PRODUCT COMPONENTS: OUTER JACKET 34.0 OZ/SQ. YD. SILICONE IMPREGNATED FIBERGLASS CLOTH. INNER JACKET, 17.7 OZ/SQ. YD. PLAIN FIBERGLASS FABRIC WITH AN OUTSIDE LAYER OF STAINLESS STEEL. TYPE 304 KNITTED WIRE MESH (0.011" DIAMETER @ 16 SF/LB.) INSULATION MATERIAL IS AN 11PFC FIBERGLASS NEEDED MAT - TYPE "F" FIBER. IS ENCAPSULATED BY THE SILICONE CLOTH, KNITTED MESH AND PLAIN FIBERGLASS CLOTH SEWN TOGETHER, PRODUCING A SELF-CONTAINED BLANKET SYSTEM. THE BLANKET SYSTEM INCLUDES FASTENERS FOR EASY INSTALLATION AND REMOVAL.
 - C. BLANKET CONSTRUCTION - BLANKET CONSTRUCTION SHALL BE SINGLE SEWN LOCK STITCH WITH MINIMUM 7 STITCHES PER INCH. ALL RAW JACKET EDGES WILL HAVE TRI-FOLD SILICONE FIBERGLASS CLOTH BONDING. NO RAW CUT JACKET EDGE WILL BE EXPOSED. STITCHING WILL BE DONE WITH A STAINLESS STEEL THREAD. MONEL STAPLES SHALL FOLLOW THE OUTER JACKET EDGE FOR REINFORCEMENT AND BE SPACED NO GREATER THAN 1 INCH.
 - D. STANDARD FASTENER (WIRE TWISTS) - A 21 GAUGE TYPE 304 STAINLESS STEEL WIRE WILL BE DOUBLED UP AND TWISTED IN A SPIRAL FASHION, WITH A MINIMUM OF 4 TO 5 TWISTS PER INCH. WIRE TWIST LENGTH WILL BE 16" OR LONGER. THE WIRE TWIST WILL BE SECURED TO THE LACING PIN AT THE PIN STEM. LACING PIN STEMS WILL BE 14 GAUGE TYPE 304 STAINLESS STEEL. PINS WILL BE HELD IN PLACE WITH 1" DIAMETER TYPE 304 STAINLESS STEEL SPEED WASHERS. WIRE TWIST WILL BE SPACED 6" ON CENTER ALONG CLOSING SEAMS WITH MATCHING LACING PINS TO LACE AND SECURE TO.
 - 3 PROVIDE ADDITIONAL 2" INSULATION ON STEAM PIPING, CONDENSATE PIPING, CONDENSATE TANK AND FLASH TANK.
 - 4 REMOVE EXISTING CLEVIS HANGER AND PROVIDE NEW CLEVIS HANGER OF A SIZE APPROPRIATE FOR THE PIPE WITH THE ADDITIONAL INSULATION THICKNESS AND INSULATION SHIELD. PIPE ROLLER HANGERS TO BE REUSED.

C.C. Johnson & Malhotra, P.C. 1100 Connecticut Ave., N.W., Suite 1017, Washington, DC 20036
 Tel: (202) 362-5000 Fax: (202) 362-5001
 www.ccmj.com

JVP Engineers, P.C.
 Consulting Engineers
 5101 Wisconsin Avenue, N.W., Suite 403
 Washington, DC 20016-4140
 Tel: (202) 362-5000
 Fax: (202) 362-5001

PROFESSIONAL STAMP:

100% CONSTRUCTION DOCUMENTS

DESIGNED: DAK					
DRAWN: MCB					
CHECKED: DAK					
	REVISION	DATE	DESCRIPTION	BY	APP.
PROJECT DRAWINGS					
CERTIFICATION			HVAC DETAILS III		HVAC
I HEREBY CERTIFY THAT THESE DOCUMENTS WERE PREPARED OR APPROVED BY ME, AND THAT I AM A DULY LICENSED ARCHITECT / PROFESSIONAL ENGINEER UNDER THE LAWS OF THE DISTRICT OF COLUMBIA			MAINTENANCE SHOP HVAC & LAUNDRY ROOM ALTERATIONS CENTRAL DETENTION FACILITY (D.C. JAIL) DEPARTMENT OF CORRECTIONS DISTRICT OF COLUMBIA		DRAWING NO. M-503
REGISTRATION NO. 7852 EXP. DATE: 08-31-2016 ARCHITECT/ENGINEER			CCJM C.C. Johnson & Malhotra, P.C. 1025 Connecticut Ave., N.W., Suite 1017 Washington, DC 20036		BUILDING ID NO.: 299 PROJECT NO.: CR-104C DATE: APR 6, 2016 SHEET: 12 OF 16

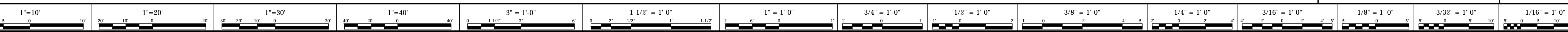

NOTE:
 ① PROVIDE 4" FOIL FACED BOARD INSULATION TO TUNNEL EAST WALL AND CEILING WHERE INDICATED. INSULATION TO BE MINERAL-FIBER BOARD INSULATION MATERIAL OR GLASS FIBERS BONDED WITH A THERMOSETTING RESIN. COMPLY WITH ASTM C 612, TYPE IA OR TYPE IB. FOR DUCT AND FLENUM APPLICATIONS, PROVIDE INSULATION WITH FACTORY-APPLIED FSK JACKET.

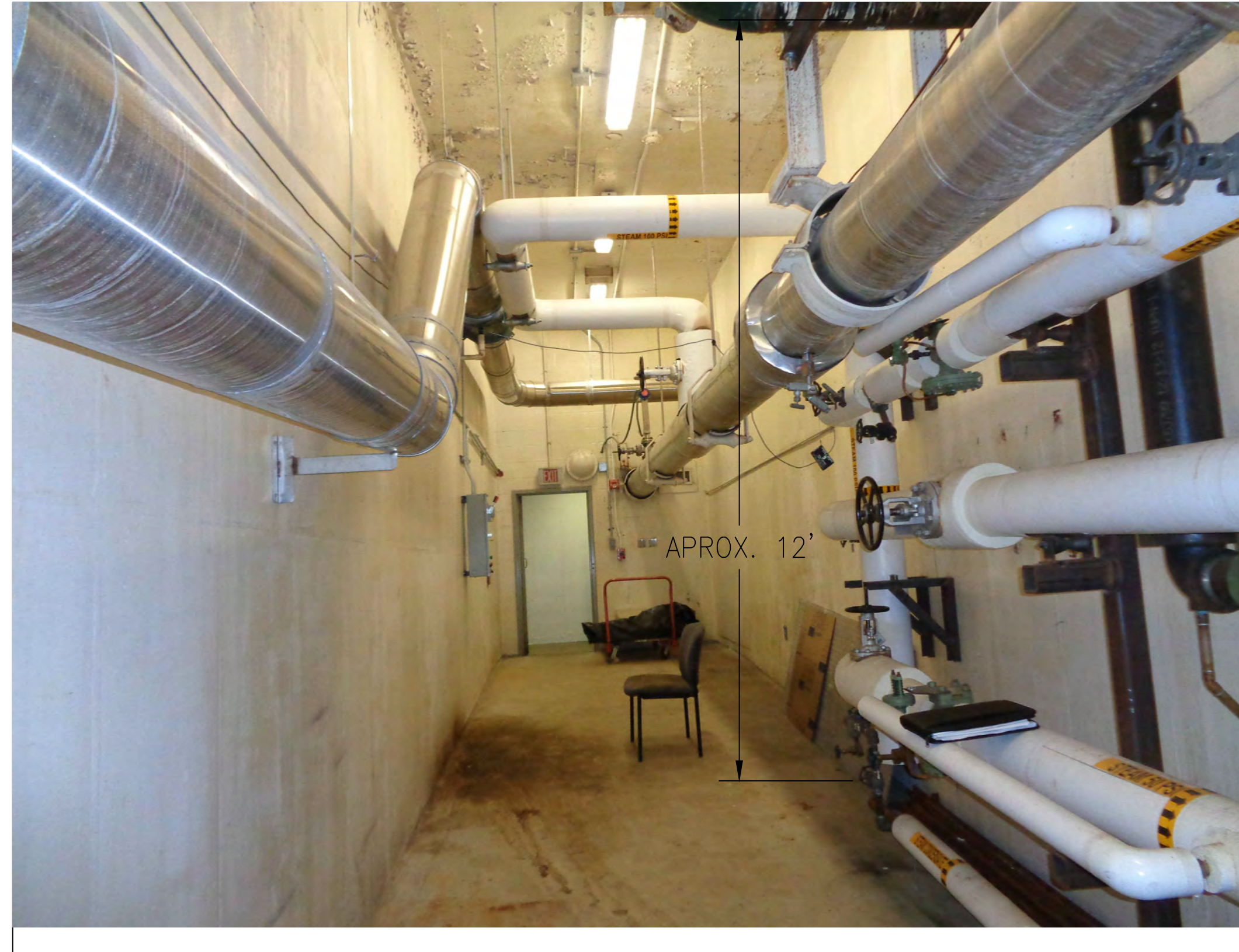

1 STEAM TUNNEL
 M-504 / NO SCALE
 SEE NOTE ①



2 STEAM TUNNEL PRESSURE REDUCING STATION
 M-504 / NO SCALE
 SEE NOTE ①

REPLACE WALL BRACKETS & HANGERS TO ACCOMMODATE ADDITIONAL INSULATION-TYPICAL



3 STEAM TUNNEL PRESSURE REDUCING STATION
 M-504 / NO SCALE
 SEE NOTE ①



4 STEAM TUNNEL PRESSURE REDUCING STATION
 M-504 / NO SCALE
 SEE NOTE ①

C.C. Johnson & Malhotra, P.C. 1025 Connecticut Ave., N.W., Suite 1017 Washington, DC 20036
 File Name: C:\Users\mcb\Documents\CCJM Projects\HVAC\HVAC Details IV\100% Construction Documents\HVAC Details IV\100% Construction Documents\Sheet M-504

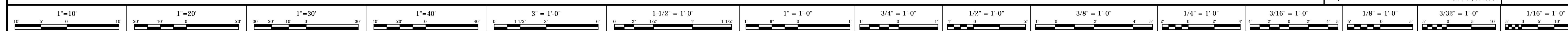

JVP Engineers, P.C.
 Consulting Engineers
 5101 Wisconsin Avenue, N.W.
 Suite 403
 Washington, DC 20016-4140
 Tel: (202) 362-5503
 Fax: (202) 362-5504

PROFESSIONAL STAMP:

100% CONSTRUCTION DOCUMENTS

DESIGNED: DAK					
DRAWN: MCB					
CHECKED: DAK					
	REVISION	DATE	DESCRIPTION	BY	APP.
PROJECT DRAWINGS					
CERTIFICATION	HVAC DETAILS IV			HVAC	
I HEREBY CERTIFY THAT THESE DOCUMENTS WERE PREPARED OR APPROVED BY ME, AND THAT I AM A DULY LICENSED ARCHITECT / PROFESSIONAL ENGINEER UNDER THE LAWS OF THE DISTRICT OF COLUMBIA	MAINTENANCE SHOP HVAC & LAUNDRY ROOM ALTERATIONS CENTRAL DETENTION FACILITY (D.C. JAIL) DEPARTMENT OF CORRECTIONS DISTRICT OF COLUMBIA			DRAWING NO. M-504	
REGISTRATION NO. 7852	CCJM C.C. Johnson & Malhotra, P.C. 1025 Connecticut Ave., N.W., Suite 1017 Washington, DC 20036			BUILDING ID NO.: 299	
EXP. DATE: 08-31-2016	GOVERNMENT OF THE DISTRICT OF COLUMBIA DEPARTMENT OF GENERAL SERVICES			PROJECT NO.: CR-104C	
ARCHITECT/ENGINEER				DATE: APR 6, 2016	
EXP. DATE: ---				SHEET: 13 OF 16	

GENERAL NOTES

- SCOPE: PROVIDE AND INSTALL ALL ELECTRICAL SYSTEMS AS INDICATED AND REQUIRED, COMPLETE AND OPERABLE.
- FURNISH ALL LABOR, MATERIALS, TOOLS, EQUIPMENT, SERVICES AND SKILLED SUPERVISION NECESSARY FOR THE CONSTRUCTION, RIGGING, ERECTION, INSTALLATION, CONNECTION, TESTING AND ADJUSTMENT OF ALL CIRCUITS AND ELECTRICAL EQUIPMENT SPECIFIED HEREIN OR SHOWN, OR NOTED ON THE DRAWINGS. DELIVER MATERIALS AND EQUIPMENT TO SITE PROTECTED, COMPLETE IN ALL RESPECTS, READY FOR INSTALLATION.
- APPLICABLE CODES, REGULATIONS & PRACTICES: ALL WORK SHALL BE PERFORMED IN ACCORDANCE WITH THE FOLLOWING CODES, REGULATIONS & PUBLICATIONS:
 A. DISTRICT OF COLUMBIA CONSTRUCTION CODE SUPPLEMENT, 2012 EDITION.
 B. ICC INTERNATIONAL BUILDING CODE, 2012 EDITION
 C. ICC INTERNATIONAL MECHANICAL CODE, 2012 EDITION
 D. ICC INTERNATIONAL PLUMBING CODE, 2012 EDITION
 E. NFPA 70, NATIONAL ELECTRICAL CODE, 2011
 F. NFPA 72, NATIONAL FIRE ALARM CODE, 2012
 G. 2010 AMERICANS WITH DISABILITIES ACT STANDARDS FOR ACCESSIBLE DESIGN.
- DRAWINGS ARE DIAGRAMMATIC AND REPRESENT THE INTENT OF THE PLANS AND SPECIFICATIONS. MANUFACTURER AND CATALOG NUMBERS ARE USED HERE STRICTLY AS REFERENCE. THEY REPRESENT THE TYPE, SIZE, CONSTRUCTION, PERFORMANCE AND LEVEL OF QUALITY DESIRED. EQUIPMENT AND APPURTENANCES FROM OTHER MANUFACTURERS THAT MATCH OR SURPASS THE CHARACTERISTICS OF THOSE REFERENCED WILL BE ACCEPTABLE, SUBJECT TO APPROVAL BY THE COTR.
- CONSULT PLANS AND DETAILS FOR TYPES OF CONSTRUCTION, HEAD ROOM, FINISHES, FURRED CEILINGS, EXACT LOCATION OF FIXTURES, EQUIPMENT AND EXACT DIMENSIONS. OWNER'S REPRESENTATIVE MUST BE NOTIFIED OF ANY VARIATIONS FROM THE DIMENSIONS AND CONDITIONS SHOWN ON THOSE DRAWINGS.
- COORDINATE MOUNTING HEIGHT OF DEVICES ON FINISHED WALLS TO PROVIDE A NEAT AND SYMMETRICAL APPEARANCE. SEE PLANS, ELEVATIONS AND DETAILS FOR HEIGHTS AND LOCATIONS OF RACEWAYS, DEVICES, AND OTHER ELECTRICAL DEVICES.
- ALL DEMOLITION, CUTTING AND PATCHING, AND INSTALLATION OF MATERIALS, CONDUITS, WIRING, AND DEVICES SHALL BE DONE IN A PROFESSIONAL MANNER IN ACCORDANCE WITH NECA 1, SHALL CONFORM TO APPLICABLE CODES, REGULATIONS AND MANUFACTURER'S RECOMMENDATIONS, AND SHALL BE COMPLETED IN A MANNER ACCEPTABLE TO THE COTR. PROVIDE PATCHING SURFACE TO MATCH ADJACENT SURFACE, AND ALSO PAINT COLOR TO MATCH ADJACENT FINISHING COLOR.
- MATERIALS AND SUBSTITUTIONS: THE CONTRACTOR SHALL SUBMIT A LIST OF ALL MATERIALS AND FIXTURES TO THE OWNER FOR APPROVAL. NO SUBSTITUTION WILL BE ALLOWED WITHOUT PERMISSION IN WRITING.
- MOUNTING HEIGHTS, UNLESS OTHERWISE NOTED, ARE TO CENTERLINE OF EQUIPMENT.
- CONDUITS: ALL CONDUITS SHALL BE NEW AND SHALL BE CUT TO EXACT LENGTHS TO SUIT THE FIELD CONDITIONS. BURRS SHALL BE REMOVED. PROVIDE BUSHINGS WHERE CONDUIT ENDS ARE EXPOSED TO CABLING.
- CONDUIT SYSTEMS: CONDUIT SHALL BE EMT (ELECTRIC METALLIC TUBING). ALUMINUM CONDUIT SHALL NOT BE PERMITTED. MINIMUM SIZE OF CONDUIT IS 3/4", RUN CONDUIT PARALLEL TO WALLS AND CEILING. FINAL CONNECTION TO LIGHT FIXTURES OR VIBRATING EQUIPMENT IS ALLOW THE INSTALLATION OF FMC, LPMC OR MC CABLE, 600 VOLT.
- OUTLET BOXES: FOUR INCH SQUARE FOR SWITCHES AND RECEPTACLES. AT LOCATIONS WHERE BOXES ARE RECESSED IN DRYWALL, PROVIDE DEVICES WITH RINGS AND PLATES APPROPRIATE TO THE TYPE OF CONSTRUCTION. EXPOSED BOXES LESS THAN 6 FT AFF SHALL NOT HAVE KNOCKOUTS ACCESSIBLE TO OCCUPANTS.
- LIGHT FIXTURES AND EXIT SIGNS SHALL BE SUPPORTED FROM CEILING STRUCTURE INDEPENDENTLY FROM CEILING GRID.
- WIRING DEVICES: DUPLEX RECEPTACLE, NEMA 5-20R AND COVER PLATE BOTH WITH RED COLOR.
- VERIFY ALL DOOR SWINGS BEFORE INSTALLING LIGHT SWITCHES. INSTALL LIGHT SWITCHES AT LATCH SIDE OF DOORS, HEIGHT PER ADA REQUIREMENTS.
- TELEPHONE AND DATA OUTLETS: AT LOCATIONS INDICATED, PROVIDE OUTLET BOX AND WITH 1" EMPTY EMT CONDUIT WITH PULL STRING UP TO 6" ABOVE FINISHED CEILING.
- WIRE AND CABLE: TYPE THWN OR THHN, 600 VOLT, COPPER CONDUCTORS, COLOR CODED. THE MINIMUM SIZE SHALL BE #12 AWG, 75°C TEMPERATURE RATING PER NEC.
- GROUNDING: ALL SYSTEMS SHALL BE GROUNDED IN ACCORDANCE WITH THE NEC, RECOMMENDED PRACTICES OF IEEE STD 1100, AND ALL LOCAL CODES. CONDUIT OR CABLE ARMOR SHALL NOT BE SOLE MEANS OF GROUNDING FOR ANY CIRCUIT.
- IDENTIFICATION: PROVIDE EQUIPMENT ENCLOSURES WITH ENGRAVED LAMINATE PLACARDS DISPLAYING EQUIPMENT DESIGNATION AND SOURCE OF POWER. LABEL PULL, JUNCTION & OUTLET BOXES USING INDELIBLE MARKER OR OTHER PERMANENT MEANS INSIDE THE COVER WITH ALL CIRCUIT NUMBERS CONTAINED INSIDE.
- PROVIDE TYPED, ACCURATE PANEL SCHEDULES FOR ALL PANELS WITHIN THE SCOPE OF WORK. INCLUDE ALL FINAL ROOM NUMBERS SERVED BY EACH CIRCUIT.
- TESTING: ALL ELECTRICAL WORK SHALL BE TESTED AS REQUIRED BY ALL AUTHORITIES HAVING JURISDICTION, USING NETA STANDARD METHODS AND EQUIPMENT.
- CLEANING: REMOVE FROM SITE ALL MATERIALS NOT USED IN THIS PROJECT. CLEAR ALL DEBRIS FROM AREA OF WORK AND LEAVE SITE IN CLEAN CONDITION. CLEAN ALL EQUIPMENT ENCLOSURES, INSIDE AND OUTSIDE.
- MAINTAIN EXISTING CIRCUITS, CONDUITS AND FEEDERS PASSING THROUGH AND SERVING UNDISTURBED AREAS. RESTORE THESE ITEMS TO MAINTAIN CONTINUITY WHERE INTERRUPTED BY DEMOLITION OR POWER TRANSFER. THE OWNER SHALL BE NOTIFIED OF POWER OUTAGES 48 HOURS IN ADVANCE.
- DO NOT DISTURB ANY WIRING WHOSE ORIGIN, FUNCTION AND UTILITY ARE UNKNOWN WITHOUT PRIOR APPROVAL FROM THE COTR. FIELD VERIFY ALL CIRCUITS IN WORK AREAS (IN CONTRACT) PRIOR TO START OF WORK.
- PROVIDE FIRESTOPPING FOR ALL CONDUIT PENETRATIONS THROUGH WALLS AND FLOOR SLABS.

GENERAL DEMOLITION NOTES

- THE CONTRACTOR SHALL FAMILIARIZE HIMSELF WITH THE EXISTING CONDITIONS TO DETERMINE EXTENT OF DEMOLITION WORK PRIOR TO INSTALLATION OF NEW WORK.
- CONTRACTOR SHALL DISCONNECT ALL FIXED EQUIPMENT SERVED BY EXISTING ELECTRICAL SERVICE PRIOR TO COMMENCEMENT OF DEMOLITION WORK. REMOVE ASSOCIATED BRANCH CIRCUITS AND FEEDERS BACK TO THE SOURCE (SOURCE IS DEFINED AS PULL/JUNCTION BOXES, OUTLETS OR PANELBOARDS). CIRCUIT CONTINUITY SHALL BE MAINTAINED FOR EXISTING ELECTRICAL DEVICES, FIXTURES AND EQUIPMENT TO REMAIN.
- ALL CUTTING AND PATCHING SHALL BE PERFORMED IN A WORKMANLIKE MANNER ACCEPTABLE TO THE OWNER.
- REMOVE ITEMS THAT ARE SHOWN HATCHED OR MARKED "X".
- OTHER DEVICES & EQUIPMENT FOUND ON WALLS TO BE DEMOLISHED, BUT NOT SHOWN ON DRAWINGS, SHALL ALSO BE REMOVED, UNLESS OTHERWISE NOTED.
- DURING DEMOLITION, VERIFY THAT JUNCTION BOXES ARE CORRECTLY LABELED WITH CIRCUITS CONTAINED WITHIN.
- CONTRACTOR SHALL COORDINATE AND REQUEST PERMISSION FOR SHUTDOWN OF EXISTING SERVICES. TIME AND MANNER OF SHUTDOWN SHALL BE SCHEDULED AND APPROVED BY THE OWNER.
- CONTRACTOR SHALL REMOVE FROM SITE ALL ELECTRICAL EQUIPMENT AND MATERIALS NOT UTILIZED IN THIS CONTRACT AND SHALL DISPOSE OF PROPERLY OR AS DIRECTED BY THE OWNER.

ABBREVIATIONS

A	AMPERE
ACU	AIR CONDITIONING UNIT
ADA	AMERICANS WITH DISABILITIES ACT
AFF	ABOVE FINISHED FLOOR
AHU	AIR HANDLING UNIT
APPROX	APPROXIMATELY
AWG	AMERICAN WIRE GAUGE
BLDG	BUILDING
C	CONDUIT
°C	DEGREES CELSIUS
CEIL	CEILING
COMM	COMMUNICATION
DEMO	DEMOLITION, DEMOLISH
DIA	DIAMETER
DISC	DISCONNECT
DN	DOWN
DWG	DRAWING
E	EXISTING
EA	EACH
E.C.	EMPTY CONDUIT
EF	EXHAUST FAN
ELEC	ELECTRICAL
EMT	ELECTRICAL METALLIC TUBING
ENT	ELECTRICAL NONMETALLIC TUBING, ENTERING
EX	EXISTING TO REMAIN
°F	DEGREES FAHRENHEIT
FL	FLOOR
FLA	FULL LOAD AMPERES
FLUOR	FLUORESCENT
FMC	FLEXIBLE METALLIC CONDUIT
FNC	FLEXIBLE NONMETALLIC CONDUIT
FT	FEET
G	GROUND
GFI	GROUND FAULT INTERRUPT
HP	HORSEPOWER
HZ	HERTZ (CYCLES PER SECOND)
IN	INCHES
JB	JUNCTION BOX
K	KELVINS
KW	KILOWATT
kVA	KILO VOLT- AMPERE
LPMC	LIQUID-TIGHT FLEXIBLE METALLIC CONDUIT
MAX	MAXIMUM
MCB	MAIN CIRCUIT BREAKER
MFR	MECHANICAL
MH	MOUNTING HEIGHT
MIN	MINIMUM
MLO	MAIN LUGS ONLY
NC	NORMALLY CLOSED
NEC	NATIONAL ELECTRICAL CODE
NEMA	NATIONAL ELECTRICAL MANUFACTURERS ASSOCIATION
NO	NORMALLY OPEN
No.	NUMBER
NOM	NOMINAL
NTS	NOT TO SCALE
P	POLE, PUMP
PH	PHASE
PIR	PASSIVE INFRARED
PLUM	PLUMBING
PNL	PANELBOARD
RCP	REFLECTED CEILING PLAN
REC, RECEPT	RECEPTACLE
RGS	RIGID GALVANIZED STEEL CONDUIT
RLA	RUNNING LOAD AMPERES
RM	ROOM
SF	SQUARE FEET
SW	SWITCH
TEL/DATA	TELEPHONE/DATA COMMUNICATION
TVSS	TRANSIENT VOLTAGE SURGE SUPPRESSOR
TWMV	TEMPERED WATER MIXING VALVES CABINET
TYP	TYPICAL
UL	UNDERWRITERS LABORATORIES
UON	UNLESS OTHERWISE NOTED
V	VOLT
W	WATT, WIRE
W/	WITH
WP	WEATHER PROOF
X	EQUIPMENT TO BE DEMOLISHED
XFMR	TRANSFORMER

POWER SYMBOLS

	4' FLUORESCENT LIGHTING FIXTURE.
	DUPLEX RECEPTACLE, 20A, 125V, NEMA 5-20R.
	FUSED DISCONNECT SWITCH.
	COMBINATION MOTOR STARTER (HOA TYPE) MOTOR RATED AND DISCONNECT SWITCH, MOUNTING HEIGHT +54" AFF UNLESS OTHERWISE NOTED.
	BRANCH CIRCUIT HOMERUN TO PANELBOARD CONCEALED IN CEILING OR WALLS. CONNECT CIRCUITS TO CIRCUIT BREAKERS IN PANELBOARD INDICATED ON FLOOR PLAN.
	BRANCH CIRCUIT CONCEALED IN CEILING OR WALLS - PROVIDE 2#12AWG + 1#12GND IN 3/4" EMT CONDUIT UON.
	# INDICATES NEW WORK KEY NOTES IN REFERENCE TO DRAWING NOTE ON SAME SHEET.
	PANELBOARD 480/277, 3Ø, 4W, SEE SCHEDULE FOR DETAILS.
	FIRE ALARM SPEAKER/STROBE.
	# INDICATES DEMOLITION KEY NOTES IN REFERENCE TO DRAWING NOTE ON SAME SHEET.
	EXIT LIGHT.
	MANUAL MOTOR STARTER.
	SINGLE POLE LIGHT SWITCH 20A, 277/120V. MOUNTING HEIGHT 42" AFF.

C.C. Johnson & Malhotra, P.C. Architect/Engineer, 1135 15th St, N.W., Suite 1017, Washington, D.C. 20004
 For Name: C.C. Johnson & Malhotra, P.C. Engineering Infrastructure Solutions, 1025 Connecticut Ave., N.W., Suite 1017, Washington, DC 20036

100% CONSTRUCTION DOCUMENTS

DESIGNED: AL					
DRAWN: AL					
CHECKED: AL					
	REVISION	DATE	DESCRIPTION	BY	APP.
PROJECT DRAWINGS					
CERTIFICATION	ELECTRICAL NOTES, ABBREVIATIONS AND LEGEND			ELECTRICAL	
I HEREBY CERTIFY THAT THESE DOCUMENTS WERE PREPARED OR APPROVED BY ME, AND THAT I AM A DULY LICENSED ARCHITECT / PROFESSIONAL ENGINEER UNDER THE LAWS OF THE DISTRICT OF COLUMBIA					
REGISTRATION NO. 7852	CCJM C.C. Johnson & Malhotra, P.C.			DRAWING NO. E-001	
EXP. DATE: 08-31-2016	1025 Connecticut Ave., N.W., Suite 1017, Washington, DC 20036			BUILDING ID NO.: 299	
ARCHITECT/ENGINEER	GOVERNMENT OF THE DISTRICT OF COLUMBIA			PROJECT NO.: CR-104C	
	DEPARTMENT OF GENERAL SERVICES			DATE: APR 6, 2016	
EXP. DATE: ---				SHEET: 15 OF 16	

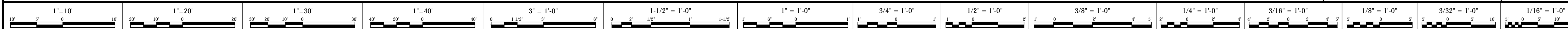

JVP Engineers, P.C.
 Consulting Engineers
 5101 Wisconsin Avenue, N.W., Suite 403
 Washington, DC 20016-4140
 Tel: (202) 362-5503
 Fax: (202) 362-5504

PROFESSIONAL STAMP

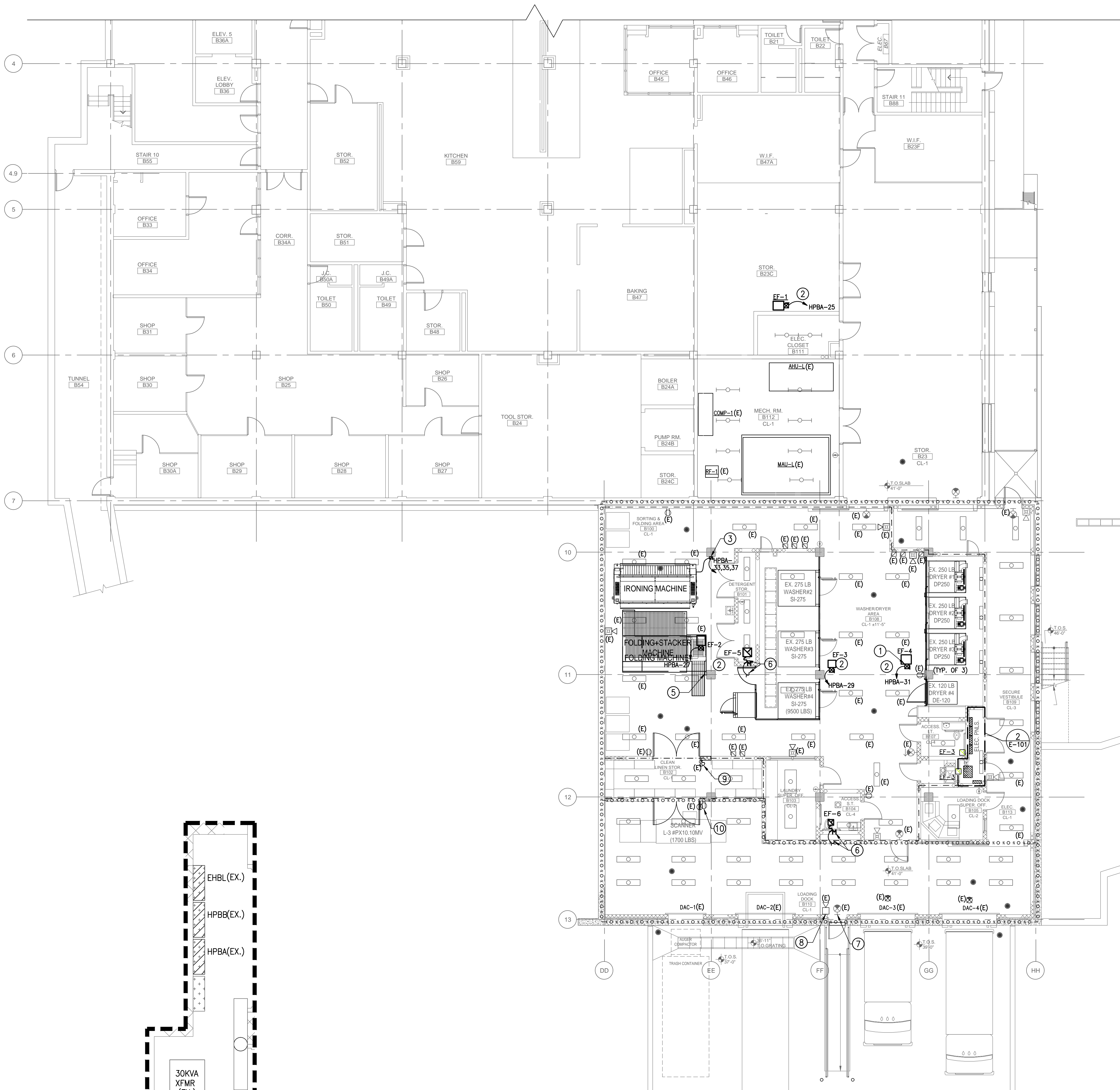

PANEL: HPBA (EXISTING)				NEUTRAL BUS: 100%		LOCATION: MAIN ELEC. ROOM - NORTH		VOLTAGE: 277/480V 3Ø 4 WIRE + GND					
FED FROM: SWITCHGEAR				GROUND BUS: YES		MOUNTING: SURFACE		MAINS BUS: 400A, COPPER					
				ISOL. GND. BUS: NO		SSC RATING: - KAIC		MAIN PROT. DEVICE: 250A, MCB					
CIR. NO.	DESCRIPTION	FEEDER CONFIG.	KVA LOAD			BREAKER amps/poles	BREAKER amps/poles			FEEDER CONFIG.	DESCRIPTION	CIR. NO.	
			A	B	C		A	B	C				
1			6.0			30/3	40/3	8.0				2	
3	EX. DRYER #1		6.0			30/3	40/3	8.0				4	
5			6.0			30/3	40/3	8.0				6	
7			6.0			30/3	40/3	8.0				8	
9	EX. DRYER #2		6.0			30/3	40/3	8.0				10	
11			6.0			30/3	40/3	8.0				12	
13			6.0			30/3	40/3	8.0				14	
15	EX. DRYER #3		6.0			30/3	40/3	8.0				16	
17			6.0			30/3	40/3	8.0				18	
19			3.0			15/3	40/3	8.0				20	
21	EX. DRYER #4		3.0			15/3	40/3	8.0				22	
23			3.0			15/3	40/3	8.0				24	
25	EF-1	2#12 + 1#12 IN 3/4" C	1.3			20/1	30/3	6.0				26	
27	EF-2	2#12 + 1#12 IN 3/4" C	1.3			20/1	30/3	6.0				28	
29	EF-3	2#12 + 1#12 IN 3/4" C	1.3			20/1	30/3	6.0				30	
31	EF-4	2#12 + 1#12 IN 3/4" C	1.3			20/1	30/3	6.0				32	
33			3.0			15/3	40/3	8.0				34	
35	NEW ROLL IRONER	3#12 + 1#12 IN 3/4" C	3.0			15/3	40/3	8.0				36	
37			3.0			15/3	40/3	8.0				38	
39	SPACE						40					40	
41	SPACE						42					42	
SUBTOTAL			25.3	25.3	25.3		EST. LOAD (KVA)		36.0	36.0	36.0	SUBTOTAL	
						183.9 KVA (CONNECTED)		61.3	61.3	61.3	TOTAL		
						- KVA (DEMAND)							

GENERAL NOTES

1. REMOVE AND RE-INSTALL ALL EXISTING POWER, LIGHT FIXTURES, ELECTRICAL EQUIPMENT AND ACCESSORIES REQUIRED FOR THE INSTALLATION OF NEW IRONING UNIT. COORDINATE WITH OWNER'S REPRESENTATIVE FOR POWER OUTAGES AND FIRE ALARM VERIFICATIONS.

POWER ELECTRICAL NEW WORK KEY NOTES

- ① PROVIDE COMBINATION DISCONNECT SWITCH-MOTOR STARTER 30A, 480V, 2-POLE WITH H.O.A. SWITCH FOR NEW EXHAUST FANS.
- ② PROVIDE NEW HOME RUN FROM MOTOR STARTER OF EXHAUST TO TERMINATE AT EXISTING SPARE CIRCUIT BREAKERS AT PANELBOARD HPBA WITH 2#12+1#12(G) IN 3/4" EMT CONDUIT. PROVIDE FINAL CONNECTION TO EXHAUST FAN MOTOR WITH 2#12+1#12(G) IN 3/4" LFMC CONDUIT.
- ③ PROVIDE DISCONNECT SWITCH-30A, 480V, 3-POLE, FUSED AT 15A FOR NEW IRONING UNIT. PROVIDE NEW HOME RUN 3#12+1#12(G) IN 3/4" C PANELBOARD AS SHOWN AND FINAL CONNECTION TO ROLL IRON UNIT WITH 3#12+1#12(G) IN 3/4" LFMC CONDUIT.
- ④ PROVIDE NEW CIRCUIT BREAKER 15A, 480V, 3-POLE AT EXISTING PANELBOARD SPACE. AIC RATING TO MATCH EXISTING.
- ⑤ DISCONNECT EXISTING FOLDING MACHINE. REMOVE THE POWER CONNECTION BACK TO THE EXISTING JUNCTION BOX AND RETAIN FOR RECONNECTION. RECONNECT THE POWER CONNECTION ONCE THE EXISTING FOLDING MACHINE IS PUT BACK IN PLACE AS PER MANUFACTURER'S RECOMMENDATIONS.
- ⑥ REPLACE EXHAUST FANS EF-5 AND EF-6. REFER TO MECHANICAL DRAWINGS. PROVIDE NEW MANUAL MOTOR STARTER DISCONNECT 20A, 120V, 1-POLE IN NEMA 1 ENCLOSURE. RECONNECT TO EXISTING CIRCUIT.
- ⑦ REMOVE AND RE-INSTALL EXISTING EXIT SIGN. REMOVE PORTION OF CONDUIT AND POWER CONNECTION BACK TO NEAREST JUNCTION BOX. REINSTALL EXISTING EXIT SIGN AND RECONNECT POWER CONNECTION ONCE THE NEW HVAC LOUVER AND DUCTWORK ARE INSTALLED. EXTEND CONDUIT AND WIRES AS REQUIRED.
- ⑧ REMOVE AND RE-LOCATE EXISTING FIRE ALARM STROBE TO ALLOW THE INSTALLATION OF NEW HVAC LOUVER AND DUCTWORK. EXTEND CONDUITS AND WIRES AS REQUIRED. COORDINATE WITH OWNER'S REPRESENTATIVE FOR TESTING AND VERIFICATION OF FIRE ALARM STROBE PERFORMANCE.
- ⑨ REMOVE AND RELOCATE LIGHT SWITCH FOR NEW DOOR OPENING. EXTEND CONDUITS AND WIRES AS REQUIRED.
- ⑩ REMOVE AND RELOCATE POWER RECEPTACLE FOR SCANNER UNIT. EXTEND CONDUITS AND WIRES AS REQUIRED.

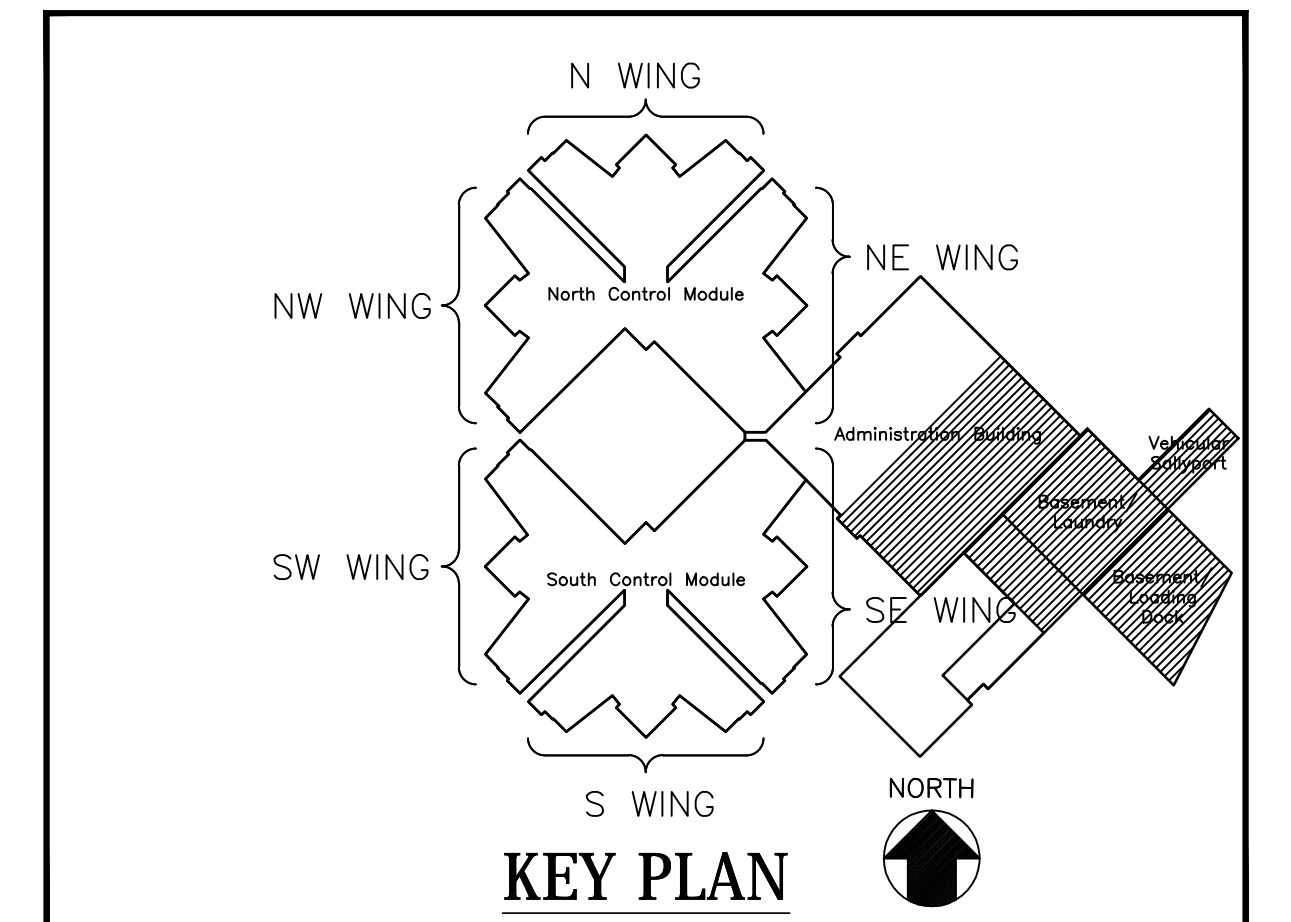

100% CONSTRUCTION DOCUMENTS

2 ENLARGED ELECTRICAL CLOSET PLAN
SCALE: 1/2" = 1'-0"

1 BASEMENT ELECTRICAL PART PLAN - POWER
SCALE: 1/8" = 1'-0"

DESIGNED: AL					
DRAWN: AL					
CHECKED: AL					
	REVISION	DATE	DESCRIPTION	BY	APP.
PROJECT DRAWINGS					
ADMINISTRATION MODULE - BASEMENT LEVEL PART PLAN - POWER				ELECTRICAL	
MAINTENANCE SHOP HVAC & LAUNDRY ROOM ALTERATIONS CENTRAL DETENTION FACILITY (D.C. JAIL) DEPARTMENT OF CORRECTIONS DISTRICT OF COLUMBIA				DRAWING NO. E-101	
REGISTRATION NO. 7852		5101 Wisconsin Avenue, N.W., Suite 403 Washington, DC 20004-1440 Tel. (202) 362-5903 Fax (202) 362-5941			
EXP. DATE: 08-31-2016		C.C. Johnson & Malhotra, P.C. 1025 Connecticut Ave., N.W., Suite 1017 Washington, DC 20036			
ARCHITECT/ENGINEER		GOVERNMENT OF THE DISTRICT OF COLUMBIA DEPARTMENT OF GENERAL SERVICES			
EXP. DATE: ---		BUILDING ID NO.: 299		PROJECT NO.: CR-104C	
		DATE: APR 6, 2016		SHEET: 16 OF 16	

C.C. Johnson & Malhotra, P.C. is an Equal Opportunity Employer. All rights reserved. No part of this document may be reproduced without the prior written permission of C.C. Johnson & Malhotra, P.C. This document is the property of C.C. Johnson & Malhotra, P.C. and is loaned to you for your use only. It is not to be distributed, copied, or otherwise used for any purpose other than that for which it was originally intended. If you have any questions regarding this document, please contact C.C. Johnson & Malhotra, P.C. at (202) 362-5903.

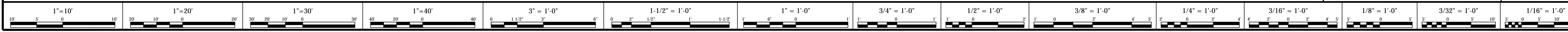

GOVERNMENT OF THE DISTRICT OF COLUMBIA
DEPARTMENT OF GENERAL SERVICES

DEPARTMENT OF CORRECTIONS
Central Detention Facility (DC Jail)
Maintenance Shop HVAC and Laundry Room Alterations
Administration Module
TECHNICAL SPECIFICATIONS

100% CONSTRUCTION DOCUMENTS

April 6, 2016



TABLE OF CONTENTS

DIVISION 0 FORMS AND DOCUMENTS, INSTRUCTIONS TO BIDDERS, AND OF THE CONDITIONS CONTRACT

Solicitation Documents

DIVISION 01 - GENERAL REQUIREMENTS

- 01 1000 SUMMARY OF WORK
- 01 2610 REQUEST FOR INFORMAITON
- 01 3100 PROJECT MANAGEMENT AND COORDINATION
- 01 3200 CONSTRUCTION PROGRESS DOCUMENTATION
- 01 3300 SUBMITTAL PROCEDURES
- 01 3516 ALTERATION PROJECT PROCEDURES
- 01 4000 QUALITY REQUIREMENTS
- 01 5000 TEMPORARY FACILITIES AND CONTROLS
- 01 6000 PRODUCT REQUIREMENTS
- 01 7300 EXECUTION
- 01 7390 CUTTING AND PATCHING
- 01 7419 CONSTRUCTION WASTE MANAGEMENT AND DISPOSAL
- 01 7700 CLOSEOUT PROCEDURES
- 01 7823 OPERATION AND MAINTENANCE DATA
- 01 7839 PROJECT RECORD DOCUMENTS
- 01 7900 DEMONSTRATION AND TRAINING

DIVISION 02 - EXISTING CONDITIONS

- 02 4119 SELECTIVE STRUCTURE DEMOLITION

DIVISION 03 – CONCRETE

RESERVED

DIVISION 04 – MASONRY

- 04 2000 UNIT MASONRY

DIVISION 05 – METALS

- 05 5000 METAL FABRICATIONS
- 05 5319 EXPANDED METAL GRATINGS

DIVISION 06 - WOOD, PLASTICS, AND COMPOSITES

RESERVED

DIVISION 07 - THERMAL AND MOISTURE PROTECTION

07 2100 THERMAL INSULATION
07 8413 PENETRATION FIRESTOPPING
07 9200 JOINT SEALANTS

DIVISION 08 – OPENINGS

08 1113 NON-DETENTION HOLLOW METAL DOORS AND FRAMES
08 7111 DOOR HARDWARE
08 9119 FIXED LOUVERS

DIVISION 09 – FINISHES

09 9123 INTERIOR PAINTING

DIVISION 10 - SPECIALTIES

RESERVED

DIVISION 11 - EQUIPMENT

11 1900 DETENTION EQUIPMENT GENERAL REQUIREMENTS
11 1910 DETENTION DOORS AND FRAMES
11 1920 DETENTION HARDWARE
11 1950 SECURITY BAR GRATING
11 1960 SECURITY FASTENERS
11 1990 SECURITY HOLLOW METAL PANEL WALL SYSTEM

DIVISION 21 – FIRE SUPPRESSION

RESERVED

DIVISION 22 - PLUMBING

RESERVED

DIVISION 23 - HEATING VENTILATING AND AIR CONDITIONING

23 0513 COMMON MOTOR REQUIREMENTS FOR HVAC EQUIPMENT
23 0519 METERS AND GAGES FOR HVAC PIPING
23 0523 GENERAL-DUTY VALVES FOR HVAC PIPING
23 0529 HANGERS AND SUPPORTS FOR HVAC PIPING AND EQUIPMENT
23 0553 IDENTIFICATION FOR HVAC PIPING AND EQUIPMENT
23 0593 TESTING, ADJUSTING, AND BALANCING FOR HVAC
23 0716 DUCT INSULATION
23 0716 HVAC EQUIPMENT INSULATION
23 0719 HVAC PIPING INSULATION
23 0900 INSTRUMENTATION AND CONTROLS FOR HVAC
23 2213 STEAM AND CONDENSATE HEATING PIPING
23 2216 STEAM AND CONDENSATE PIPING SPECIALTIES

- 23 3113 METAL DUCTS
- 23 3300 AIR DUCT ACCESSORIES
- 23 3423 HVAC POWER VENTILATORS
- 23 3713 DIFFUSERS, REGISTERS, AND GRILLES

DIVISION 26 - ELECTRICAL

- 26 0519 LOW-VOLTAGE ELECTRICAL POWER CONDUCTORS AND CABLES
- 26 0526 GROUNDING AND BONDING FOR ELECTRICAL SYSTEMS
- 26 0529 HANGERS AND SUPPORTS FOR ELECTRICAL SYSTEMS
- 26 0533 RACEWAYS AND BOXES FOR ELECTRICAL SYSTEMS
- 26 0544 SLEEVES AND SLEEVE SEALS FOR ELECTRICAL RACEWAYS AND CABLING
- 26 0553 IDENTIFICATION FOR ELECTRICAL SYSTEMS
- 26 2813 FUSES
- 26 2816 ENCLOSED SWITCHES AND CIRCUIT BREAKERS
- 26 2913 ENCLOSED CONTROLLERS

END OF TABLE OF CONTENTS

SECTION 011000 – SUMMARY OF WORK

PART 1 - GENERAL

1.1 SUMMARY

A. Section Includes:

1. Project information.
2. Work covered by Contract Documents.
3. Construction Sequencing
4. Access to site.
5. Coordination with occupants.
6. Work restrictions.
7. Specification and drawing conventions.

B. Related Sections:

1. Division 1 Section "Temporary Facilities and Controls" for limitations and procedures governing temporary use of Owner's facilities.

1.2 PROJECT INFORMATION

A. Project Identification: Maintenance Shop HVAC & Laundry Room Alterations – Administration Module

1.3 Project Location: Department of Corrections
Central Detention Facility (D.C Jail)
1901 'D' Street, S.E.
Washington, D. C. 20003

A. Owner: D.C. Department of General Services

1. Owner's Representative: Satish Bagai
Construction Division
D.C. Department of General Services
1250 U Street, NW - 4th Floor
Washington, DC 20009
TEL: (202) 478-9132

B. Architect/Engineer: C.C. Johnson & Malhotra, P.C.
1025 Connecticut Ave, N.W., Suite 1017
Washington, DC 20036
TEL: (202) 363-0465

1.4 WORK COVERED BY CONTRACT DOCUMENTS

- A. The Work of Project is defined by the Contract Documents and consists of the following for the IRC Maintenance Shop Area and Laundry Room Alterations at Central Detention Facility (D. C. Jail) located in the Existing Administration Module:
1. Alterations to HVAC System to provide additional insulation for steam and condensate piping and equipment in the IRC Basement area,
 2. Additional HVAC modifications and new doors for new ironer unit in Laundry Room.
 3. Wiremesh panels and insulated metal panels enclosures around existing washer and dryer units in Laundry Room.
 4. The project will be conducted in a single, continuous process with some sequencing required at the very beginning and end of the project.
- B. Type of Contract:
1. Project will be constructed under a single prime contract.

1.5 CONSTRUCTION SEQUENCING

- A. On-Going Facility Operation: Existing Laundry Room is currently not in operation and Maintenance Area will remain occupied. The rest of the Basement Floor area to be renovated is occupied by the DOC.
1. The remainder of secure facility operations at CDF will continue during the project; which will require coordination with the Department of Correction (DC DOC) Refer to Section 013100 following for security and coordination requirements with the DC DOC.
- B. Initial Preparation: While a single continuous construction process is proposed, some initial work needs to be performed in order for the overall work to proceed. Initial Preparation work will include:
1. Construction of two new doors in Laundry Room to allow for the rigging of the new ironer unit;
 2. HVAC and electrical rough-ins for the ironer unit.
 3. HVAC ventilation system alterations.
 4. Renovation work within Maintenance Shop Area and Tunnel area.
 5. Temporary disconnection and relocation of folder unit and scanner unit under separate contracts, which will require close coordination with the Contractor.
 6. At the completion and acceptance of the Initial Preparation Work, the Main Construction Work may commence.
- C. Main Construction Work: The Main Construction Work will involve the balance of all work on the project, with the exception of the Final Work Elements described in item D. following. Primary aspects of the Main Construction Work include (but are not limited to):

1. New Ironer equipment is to be provided by DOC's contracted laundry services provider, which will require close coordination with the Contractor. Details of new laundry equipment will be provided at contract execution.
 2. All construction in Laundry Room.
- D. Final Work Elements: Once the Main Construction work is completed, a few Final Work Elements need to be accomplished, including:
1. Final connections and operational start-up testing for ironer and folder units.
 2. Start-up, testing, adjusting, and balancing of HVAC systems.
- E. Before commencing Work, submit an updated copy of the Contractor's construction schedule showing the sequence, commencement and completion dates, and move-out for all aspects of the project.
- F. Substantial Completion for the Work.
- G. The Work shall be conducted in sequence as described above, and the Contractor shall notify the COTR when each segment has been completed.

1.6 ACCESS TO SITE

- A. General: Contractor shall have limited use of Project site for construction operations as indicated on Drawings and as indicated by requirements of this Section.
1. Work Area Access: Generally accessible after going through security screening and escort.
 2. Limits: Confine construction operations to the immediate vicinity of the work and designated access routes. As required, DOC will provide access to the secure part of the facility for penetration connections and other work that must be performed within the secure part of the facility. Similarly, access to exterior and Basement Level construction work shall only be from outside of the secure part of the facility, except as arranged with DOC in advance.
 3. Driveways, Walkways and Entrances: Keep driveways, parking, loading areas and entrances serving premises clear and available to Owner, Owner's employees and official vehicles at all times. Do not use these areas for parking or storage of materials.
 - a. Schedule deliveries to minimize use of driveways and entrances by construction operations.
 - b. Schedule deliveries to minimize space and time requirements for storage of materials and equipment on-site.
- B. Condition of Existing Building: Maintain portions of existing building affected by construction operations in a secure and weather tight condition throughout construction period. Repair damage caused by construction operations.

1.7 COORDINATION WITH OCCUPANTS

- A. Partial Owner Occupancy: Owner will occupy the premises during entire construction period. Cooperate with Owner during construction operations to minimize conflicts and facilitate Owner usage. Perform the Work so as not to interfere with Owner's operations. Maintain existing exits unless otherwise indicated.
1. Maintain access to existing walkways, corridors, and other adjacent occupied or used facilities. Do not close or obstruct walkways, corridors, or other occupied or used facilities without written permission from Owner and authorities having jurisdiction.
 2. Provide not less than 72 hours' notice to Owner of activities that will affect Owner's operations.
 3. Movement of materials into/ out of work areas to be coordinated with DC DOC to minimize potential inmate contact.

1.8 WORK RESTRICTIONS

- A. Work Restrictions, General: Comply with restrictions on construction operations.
1. Comply with limitations on use of public streets and other requirements of authorities having jurisdiction.
 2. Contractor to consider the access plans included as part of the full size construction documents as it relates to the street as outlined on the construction documents and will comply with any required jurisdictional requirements as it relates to public street and sidewalk activity including but not limited to loading, locating dumpster, unloading, temporary storage structures, boom (lift) equipment, sidewalks, etc.
- B. On-Site Work Hours: Limit work in the existing building to normal business working hours Monday through Friday. Additional work hours may be scheduled with the DC DOC, provided this is done 72 hours in advance.
1. On site normal business hours at the CDF are defined as 6:00AM to 2:30PM. Additional hours outside of this time period are possible, but will require special arrangements with DC DOC point of contact.
 2. The Contractor may establish standard work day hours with the DC DOC for access for work areas outside the secure part of the facility that do not align with their 6:00 AM to 2:30 PM work day; however, access into the secure parts of CDF may be limited to those hours.
- C. Access/Logistics: Contractor needs to understand the full processes that occur to gain access in and out of this specific facility. The required pre-bid walk through will give the Contractors a physical reference point and provide the opportunity to ask specific questions to DOC's appropriate staff.
1. Any employees who will be working on site will need to go through background check, which requires a copy of photo identification be submitted not less than 72 hours prior to a scheduled work day. DC DOC will maintain a file of approved Contractor employees.

2. Contractor regular working employees will be issued temporary Contractor ID badges which can help identify them more quickly for access into the work site.
 3. Contractors are to check in and/or enter through the visitors-contractors entrance unless otherwise designated by DC DOC point of contact. They will be escorted by DC DOC staff to their work areas, if required, and will have one guard with them at all times when they are inside the secure part of the facility.
 4. Contractor's entire staff should plan to meet and start-end work at the exact same designed hours so that additional staff is not required to escort in and out throughout the day. There will be a formal security check upon entering any secure part of the CDF, including X-ray screening, and listing all tools or equipment being brought inside. All tools and equipment are to be accounted for upon exiting the secure part of the facility.
 5. Only a single pre-designated and DC DOC approved foreman will be allowed to bring a cell phone device into the facility. All others will be restricted from bringing cell phones or other similar devices into the premises.
 6. The contractor is permitted to place a single 40 CY dumpster near the loading dock for the duration of the project. Truck access for pick up and drop off will need to be pre-scheduled and pre-approved by personnel at the DC Jail. These trucks will be subject a security check for any material that needs to go into the secure part of CDF.
 7. All tools brought into the secure part of the facility will need to be logged in and approved prior to bringing into the CDF. A gang box will be allowed and shall be kept in the individual area that the contractor is working in. This will require a daily accounting of all tools and lock up on a daily basis.
 8. Materials and debris can only be transported in and out of the secure part of the facility on a pre-arranged basis. There will be absolutely no staging / storing of any materials in any secure facility areas.
 9. Contractor needs to fully understand and consider the designated window access points as it relates to bringing materials in from and out to the exterior staging areas designated on the full size plans. These access points need to be fully secured at all other times. Specific daily procedure will be developed with DC DOC staff.
- D. Noise, Vibration, and Odors: Coordinate operations that may result in high levels of noise and vibration, odors, or other disruption to Owner occupancy with Owner.
1. Notify Owner's Representative not less than 72 hours in advance of proposed disruptive operations.
 2. Obtain written permission from Owner's Representative before proceeding with disruptive operations.
- E. Nonsmoking Building: Smoking is not permitted within the building or within 50 feet of entrances, operable windows, or outdoor air intakes.
- F. Contraband: Contraband, as defined in DC DOC policy, is not permitted on the secure perimeter of the existing building property.

1.9 SPECIFICATION AND DRAWING CONVENTIONS

- A. Specification Content: The Specifications use certain conventions for the style of language and the intended meaning of certain terms, words, and phrases when used in particular situations. These conventions are as follows:
1. Imperative mood and streamlined language are generally used in the Specifications. The words "shall," "shall be," or "shall comply with," depending on the context, are implied where a colon (:) is used within a sentence or phrase.
 2. Specification requirements are to be performed by Contractor unless specifically stated otherwise.
- B. Division 1 General Requirements: Requirements of Sections in Division 1 apply to the Work of all Sections in the Specifications.
- C. Drawing Coordination: Requirements for materials and products identified on the Drawings are described in detail in the Specifications. One or more of the following are used on the Drawings to identify materials and products:
1. Terminology: Materials and products are identified by the typical generic terms used in the individual Specifications Sections.
 2. Abbreviations: Materials and products are identified by abbreviations as scheduled on Drawings.

PART 2 - PRODUCTS (Not Used)

PART 3 - EXECUTION (Not Used)

END OF SECTION 011000

SECTION 012610 - REQUEST FOR INTERPRETATION (RFI)

PART 1 - GENERAL

1.1 RELATED DOCUMENTS

- A. Drawings and general provisions of the Contract, including General and Supplementary Conditions and other Division 01 Specification Sections, apply to this Section.

1.2 SUMMARY

- A. This Section specifies administrative and procedural requirements for handling and processing Requests for Interpretation.
- B. Related Sections include the following:
 - 1. Division 01 Section "Project Management and Coordination."
 - 2. Division 01 Section "Submittal Procedures".
 - 3. Division 01 Section "Product Requirements" for product and substitution requirements.

1.3 DEFINITIONS

- A. Request for Interpretation (RFI): Request from Contractor seeking interpretation or clarification of some requirement of Contract Documents and not involving change in Contract Sum or Contract Time.
 - 1. Improper RFI: An RFI meeting any of the following conditions:
 - a. RFI not prepared in accordance with requirements of this Section
 - b. RFI missing graphic solution proposal from contractor where appropriate
 - c. RFI with subject listed as improper subject matter in "GENERAL" article of this section.
 - 2. Frivolous RFI: RFI that requests information that is clearly indicated on or reasonably inferable from Contract Documents.
- B. Proposal Request: Document issued by Architect after Contract award which may include drawings and other information used to solicit proposal for change in Work.

1.4 GENERAL

- A. Immediately on discovery of the need for additional information or interpretation of the Contract Documents, Contractor shall prepare and submit an RFI in the form specified.

- B. Submit RFI from subcontractor or material supplier through Contractor who shall review and sign each RFI prior to submittal.
 - 1. Architect will return RFIs submitted to Architect by other entities controlled by Contractor with no response.
 - 2. Coordinate and submit RFIs in a prompt manner so as to avoid delays in Contractor's work or work of subcontractors.

- C. Improper subjects for RFIs: Do not submit RFI for following:
 - 1. To request approval of submittals. Comply with Division 01 Section "Submittal Procedures."
 - 2. To request approval of substitutions. Comply with Division 01 Section "Product Requirements."
 - 3. To request coordination of various materials and systems indicated on Contract Documents with field conditions and with each other. Comply with Division 01 Section "Project Management and Coordination."
 - 4. To provide as-built information required by Record Documents specified in Division 01 Section "Project Record Documents."
 - 5. Requests for interpretation of Architect's actions on submittals.
 - 6. Incomplete RFIs or inaccurately prepared RFIs.

1.5 REQUEST FOR INTERPRETATION (RFI)

- A. General:
 - 1. RFI is a request for interpretation only. If Contractor believes response to RFI results in change in Contract Sum, Contract Time, or both, comply with Contract Modification Procedures.
 - 2. Submit RFI on form attached at the end of this section or on another form, subject to Architect's prior review and approval. Form shall be completely filled in and if prepared by hand, shall be fully legible after photocopying or transmission by facsimile (FAX).
 - 3. RFI may be submitted by e-mail or via web-based system. Address for e-mail or web address and login information will be distributed at Pre-Construction Conference. Electronic form of attached Request for Interpretation will be provided upon request.

- B. Number RFIs sequentially using only next sequential number. Do not include subcontractors RFI number on form; include date submitted.
 - 1. Each page of attachments to RFI shall bear RFI number and shall be consecutively numbered.

- C. Content of RFIs:
 - 1. Specifically identify time response interpretation is required to avoid impact on Construction Schedule and Cost.
 - 2. Include a detailed, legible description of item needing information or interpretation and the following:

- a. Project name.
- b. Project number.
- c. Date.
- d. Name of Contractor.
- e. Name of Architect and Construction Manager.
- f. RFI number, numbered sequentially.
- g. RFI subject.
- h. Specification Section number and title and related paragraphs, as appropriate.
- i. Drawing number and detail references, as appropriate.
- j. Field dimensions and conditions, as appropriate.
- k. Contractor's suggested resolution.
 - 1) If Contractor's solution(s) impacts the Contract Time or the Contract Sum, Contractor shall state impact in the RFI.
- l. Contractor's signature.
- m. Attachments: Include sketches, descriptions, measurements, photos, Product Data, Shop Drawings, coordination drawings, and other information necessary to fully describe items needing interpretation.
 - 1) Include dimensions, thicknesses, structural grid references, and details of affected materials, assemblies, and attachments on attached sketches.

D. RFI shall include written and graphic solutions proposed by Contractor. Following consultation with Construction Manager, Architect will determine if proposal is in accord with Contract Documents and design intent of Project.

1. Contractor's failure to make reasonable effort to propose realistic solution may result in Request for Interpretation returned with no action.
2. Submit separate RFI for each item or, subject to Architect's approval, group of closely related items requiring interpretation or clarification. RFIs containing more than a single item or group of closely related items not approved by Architect will be returned unanswered or will be reviewed with the time specified for review allotted to each individual item, at Architect's discretion.

E. Improper or Frivolous RFI:

1. Will be returned unanswered and shall be labeled as frivolous in the official RFI log.
2. At Contractor's request, after notification by Architect that RFI is improper or frivolous, RFI will be processed with processing costs charged to Contractor as follows:
 - a. Contractor shall reimburse Owner for Construction Manager's and Architect's account for time spent in processing improper or frivolous RFI at rate of 2.9 times rate of Direct Personnel Expense (DPE). Direct Personnel Expense is defined as direct salaries of Construction Manager's and Architect's personnel engaged on Project and portion of costs of mandatory, and customary contributions and benefits related thereto,

including employment taxes and other statutory employee benefits, insurance, sick leave, holidays, vacations, pensions, and similar contributions and benefits.

- F. For RFIs submitted in form of drawings, follow submittal procedures specified for Shop Drawings in Division 01 Section "Submittal Procedures."

1.6 REVIEW AND SUBMITTAL

- A. Submit Electronic copy of completed RFI form to Construction Manager, including required attachments.
 - 1. RFI received on Friday afternoon will not be processed until following Monday, which will be recorded receipt of RFI date.
- B. Allow minimum of 7 working days review and response time for each RFI.
 - 1. Requested response time indicated on RFI shall be consistent with minimum review period specified.
 - 2. Requested response time will be extended where required by concurrent review of excessive number of RFIs, including improper and frivolous RFIs.
- C. Architect's and Construction Manager's Action: Architect and Construction Manager will review each RFI, determine action required, and respond.
 - 1. The following RFIs will be returned without action:
 - a. RFIs that meet improper or frivolous definitions as listed in this section.
 - 2. Architect's action may include a request for additional information, in which case Architect's time for response will date from time of receipt of additional information.
 - 3. Architect's action on RFIs that may result in a change to the Contract Time or the Contract Sum may be eligible for Contractor to submit Change Proposal according to Contract Modification Procedures.
 - a. If Contractor believes the RFI response warrants change in the Contract Time or the Contract Sum, notify Architect and Construction Manager in writing within 10 days of receipt of the RFI response.
- D. On receipt of Architect's and Construction Manager's action, update the RFI log and immediately distribute the RFI response to affected parties. Review response and notify Architect and Construction Manager within seven days if Contractor disagrees with response.
- E. RFI Log: Prepare, maintain, and submit a tabular log of RFIs organized by the RFI number. Submit log weekly and as requested by Construction Manager or Architect. Include the following:
 - 1. Project name.

2. Name and address of Contractor.
3. Name and address of Architect and Construction Manager.
4. RFI number including RFIs that were dropped and not submitted.
5. RFI description.
6. Date the RFI was submitted.
7. Date Architect's and Construction Manager's responses were received.
8. Identification of related Minor Change in the Work, Construction Change Directive, and Proposal Request, as appropriate.

PART 2 - PRODUCTS (Not Used)

PART 3 - EXECUTION (Not Used)

END OF SECTION 012610

SECTION 013100 - PROJECT MANAGEMENT AND COORDINATION

PART 1 - GENERAL

1.1 RELATED DOCUMENTS

- A. Drawings and general provisions of the Contract, including General and Supplementary Conditions and other Division 01 Specification Sections, apply to this Section.

1.2 SUMMARY

- A. Section includes administrative provisions for coordinating construction operations on Project including, but not limited to, the following:
 - 1. General project coordination procedures.
 - 2. Administrative and supervisory personnel.
 - 3. Coordination drawings.
 - 4. Project meetings.
- B. Related Sections:
 - 1. Division 01 Section "Request for Interpretation (RFIs)" for preparing and submitting RFIs.
 - 2. Division 01 Section "Construction Progress Documentation" for preparing and submitting Contractor's construction schedule.
 - 3. Division 01 Section "Execution" for procedures for coordinating general installation and field-engineering services, including establishment of benchmarks and control points.
 - 4. Division 01 Section "Closeout Procedures" for coordinating closeout of the Contract.

1.3 DEFINITIONS

- A. RFI: Request from Owner, Architect, or Contractor seeking information from each other during construction.

1.4 COORDINATION

- A. Coordination: Coordinate construction operations included in different Sections of the Specifications to ensure efficient and orderly installation of each part of the Work. Coordinate construction operations, included in different sections, that depend on each other for proper installation, connection, and operation.

1. Schedule construction operations in sequence required to obtain the best results where installation of one part of the Work depends on installation of other components, before or after its own installation.
 2. Coordinate installation of different components to ensure maximum performance and accessibility for required maintenance, service, and repair.
 3. Make adequate provisions to accommodate items scheduled for later installation.
 4. Where availability of space is limited, coordinate installation of different components to ensure maximum performance and accessibility for required maintenance, service, and repair of all components, including mechanical and electrical.
- B. Prepare memoranda for distribution to each party involved, outlining special procedures required for coordination. Include such items as required notices, reports, and list of attendees at meetings.
1. Prepare similar memoranda for Owner and separate contractors if coordination of their Work is required.
- C. Administrative Procedures: Coordinate scheduling and timing of required administrative procedures with other construction activities to avoid conflicts and to ensure orderly progress of the Work. Such administrative activities include, but are not limited to, the following:
1. Preparation of Contractor's construction schedule.
 2. Preparation of the schedule of values.
 3. Installation and removal of temporary facilities and controls.
 4. Delivery and processing of submittals.
 5. Progress meetings.
 6. Pre-installation conferences.
 7. Project closeout activities.
 8. Startup and adjustment of systems.
 9. Project closeout activities.
- D. Conservation: Coordinate construction activities to ensure that operations are carried out with consideration given to conservation of energy, water, and materials. Coordinate use of temporary utilities to minimize waste.
1. Salvage materials and equipment involved in performance of, but not actually incorporated into, the Work. Refer to other Sections for disposition of salvaged materials that are designated as Owner's property.
- E. Equipment: Verify characteristics of elements of interrelated operating equipment are compatible; coordinate Work of various Sections having interdependent responsibilities for installing, connecting to, and placing in service, such equipment.
1. Spaces: Coordinate space requirements and installation of electrical, and other Work indicated diagrammatically.
 - a. Resolve routing and space allocations before Work is started in order to prevent interference and loss of time.

- b. Assist in apportioning space conditions to make satisfactory adjustments where installed Work in close proximity to work of other contractors will interfere with other Work.
2. Follow routing indicated for conduits as closely as practicable. .
 - a. Adjust location of conduits to avoid encountered and anticipated interference.
 - b. Determine exact route and location of each conduit prior to installation.

1.5 COORDINATION DRAWINGS

- A. Coordination Drawings, General: Prepare coordination drawings that reflect coordinated construction operations included in different Sections of the Specifications and facilitate efficient and orderly installation of each part of the Work. Also coordination drawings shall reflect coordinated construction operations, included in different Sections, which depend on each other for proper installation, connection, and operation.
 1. Coordination drawings shall reflect scheduling of construction operations in sequence required to obtain the best results where installation of one part of the Work depends on installation of other components, before or after its own installation.
 2. Coordination drawings shall reflect coordinated installation of different components with other contractors to ensure maximum accessibility for required maintenance, service, and repair.
 3. Coordination drawings shall reflect adequate provisions to accommodate items scheduled for later installation.
 4. Coordination drawings shall reflect, where availability of space is limited, coordinated installation of different components to ensure maximum performance and accessibility for required maintenance, service, and repair of all components, including mechanical and electrical.
 5. Requirement for submittal of coordination drawings includes but is not limited to:
 - a. Fabrication and installation of cell and other security doors.
 - b. Installation of locking, operating mechanisms, and control devices.
 - c. Combined Mechanical, Electrical, Plumbing and Fire Protection drawings including ductwork openings and pipe sleeves.
 - d. Steel framing and miscellaneous metals.
 - e. Access panels
 6. Content: Project-specific information, drawn accurately to a scale large enough to indicate and resolve conflicts. Do not base coordination drawings on standard printed data. Include the following information, as applicable:
 - a. Use applicable Drawings as a basis for preparation of coordination drawings. Prepare sections, elevations, and details as needed to describe relationship of various systems and components.

- b. Coordinate the addition of trade-specific information to the coordination drawings by multiple subcontractors in a sequence that best provides for coordination of the information and resolution of conflicts between installed components before submitting for review.
 - c. Indicate functional and spatial relationships of components of architectural, structural, detention equipment, control, and electrical systems.
 - d. Indicate space requirements for routine maintenance and for anticipated replacement of components during the life of the installation.
 - e. Show location and size of access doors required for access to concealed electrical, door locking and operation, and other controls.
 - f. Indicate required installation sequences.
 - g. Indicate dimensions shown on the Drawings. Specifically note dimensions that appear to be in conflict with submitted equipment and minimum clearance requirements. Provide alternate sketches to Owner indicating proposed resolution of such conflicts. Minor dimension changes and difficult installations will not be considered changes to the Contract.
7. Comply with shop drawing submittal requirements specified in Division 01 Section "Submittal Procedures."
- a. Coordination Drawings are submitted for information only. They will not be reviewed and they will not be returned.
- B. Coordination Drawing Organization: Organize coordination drawings as follows:
1. Floor Plans: Show architectural and structural elements, and detention equipment, electronic security, and electrical Work. Show locations of visible devices. Supplement plan drawings with section drawings where required to adequately represent the Work.
 2. Structural Penetrations: Indicate penetrations and openings required for all disciplines.
 3. Slab Edge and Embedded Items: Indicate slab edge locations and sizes and locations of embedded items for metal fabrications, sleeves, anchor bolts, bearing plates, angles, and similar items.
 4. Security Electronics and Electrical Work: Show the following:
 - a. Runs of vertical and horizontal conduit 1-1/4 inch diameter and larger.
 - b. Panel board, switch board, switchgear, transformer, busway, UPS, and security equipment locations.
 5. Review: Owner will review coordination drawings to confirm that the Work is being coordinated, but not for the details of the coordination, which are the Contractor's responsibility. If the Owner determines that the coordination drawings are not being prepared in sufficient scope or detail, or are otherwise deficient, the Owner will so inform the Contractor, who shall make changes as directed and resubmit.
- C. Coordination Digital Data Files: Prepare coordination digital data files in accordance with the following requirements:

1. File Preparation Format: Same digital data software program, version, and operating system as the original Drawings.
2. File Submittal Format: Submit or post coordination drawing files using format same as file preparation format.
3. Architect will furnish Contractor one set of digital data files of the Drawings for use in preparing coordination digital data files.
 - a. Architect makes no representations as to the accuracy or completeness of digital data files as they relate to the Drawings.
 - b. Digital Data Software Program: The Drawings are available in AutoCAD 2008.
 - c. Contractor shall execute a data licensing agreement in the form of an Agreement form acceptable to the Owner and Architect.

1.6 KEY PERSONNEL

- A. Key Personnel Names: Within 15 days of starting construction operations, submit a list of key personnel assignments, including superintendent and other personnel in attendance at Project site. Identify individuals and their duties and responsibilities; list addresses and telephone numbers, including home, office, and cellular telephone numbers and email addresses. Provide names, addresses, and telephone numbers of individuals assigned as standbys in the absence of individuals assigned to Project.
 1. Post copies of list in project meeting room, in temporary field office, and by each temporary telephone. Keep list current at all times.

1.7 PROJECT MEETINGS

- A. General: Owner will schedule and conduct meetings and conferences at Project site, unless otherwise indicated. Owner will:
 1. Attendees: Schedule and inform participants and others involved, and individuals whose presence is required, of date and time of each meeting. Notify Owner and Architect of scheduled meeting dates and times.
 2. Agenda: Prepare the meeting agenda. Distribute the agenda to all invited attendees.
 3. Minutes: Record significant discussions and agreements achieved. Distribute the meeting minutes to everyone concerned, including Owner and Architect within 3 days of the meeting.
- B. Preconstruction Conference: Owner will schedule and conduct a preconstruction conference before starting construction, at a time convenient to Owner and Architect, but no later than 15 days after execution of the Agreement.
 1. Conduct the conference to review responsibilities and personnel assignments.
 2. Attendees: Authorized representatives of Owner, DC Department of Corrections, Architect, and their consultants; Contractor and its superintendent; major subcontractors; suppliers; and other concerned parties shall attend the

- conference. Participants at the conference shall be familiar with Project and authorized to conclude matters relating to the Work.
3. Agenda: Discuss items of significance that could affect progress, including the following:
 - a. Tentative construction schedule.
 - b. Phasing.
 - c. Critical work sequencing and long-lead items.
 - d. Designation of key personnel and their duties.
 - e. Lines of communications.
 - f. Procedures for processing field decisions and Change Orders.
 - g. Procedures for RFIs.
 - h. Procedures for testing and inspecting.
 - i. Procedures for processing Applications for Payment.
 - j. Distribution of the Contract Documents.
 - k. Submittal procedures.
 - l. Preparation of record documents.
 - m. Use of the premises.
 - n. Work restrictions.
 - o. Working hours.
 - p. Owner's occupancy requirements.
 - q. Responsibility for temporary facilities and controls.
 - r. Procedures for disruptions and shutdowns.
 - s. Construction waste management and recycling.
 - t. Parking availability.
 - u. Office, work, and storage areas.
 - v. Equipment deliveries and priorities.
 - w. First aid.
 - x. Security.
 - y. Progress cleaning.
 4. Minutes: Owner will record and distribute meeting minutes.
- C. Pre-installation Conferences: Contractor to conduct a pre-installation conference at Project site before each construction activity that requires coordination with other construction.
1. Attendees: Installer and representatives of manufacturers and fabricators involved in or affected by the installation and its coordination or integration with other materials and installations that have preceded or will follow, shall attend the meeting. Advise Owner's Representative(s), Architect, Owner of scheduled meeting dates.
 2. Agenda: Review progress of other construction activities and preparations for the particular activity under consideration, including requirements for the following:
 - a. Contract Documents.
 - b. Options.
 - c. Related RFIs.
 - d. Related Change Orders.

- e. Purchases.
 - f. Deliveries.
 - g. Submittals.
 - h. Review of mockups.
 - i. Possible conflicts.
 - j. Compatibility problems.
 - k. Time schedules.
 - l. Weather limitations.
 - m. Manufacturer's written recommendations.
 - n. Warranty requirements.
 - o. Compatibility of materials.
 - p. Acceptability of substrates.
 - q. Temporary facilities and controls.
 - r. Space and access limitations.
 - s. Regulations of authorities having jurisdiction.
 - t. Testing and inspecting requirements.
 - u. Installation procedures.
 - v. Coordination with other work.
 - w. Required performance results.
 - x. Protection of adjacent work.
 - y. Protection of construction and personnel.
3. Record significant conference discussions, agreements, and disagreements, including required corrective measures and actions.
 4. Reporting: Distribute minutes of the meeting to each party present and to other parties requiring information.
 5. Do not proceed with installation if the conference cannot be successfully concluded. Initiate whatever actions are necessary to resolve impediments to performance of the Work and reconvene the conference at earliest feasible date.
- D. Project Closeout Conference: Owner will schedule and conduct a Project closeout conference, at a time convenient to Owner and Architect, but no later than 30 days prior to the scheduled date of Substantial Completion.
1. Conduct the conference to review requirements and responsibilities related to Project closeout.
 2. Attendees: Authorized representatives of Owner, Owner, Architect, and their consultants; Contractor and its superintendent; major subcontractors; suppliers; and other concerned parties shall attend the meeting. Participants at the meeting shall be familiar with Project and authorized to conclude matters relating to the Work.
 3. Agenda: Discuss items of significance that could affect or delay Project closeout, including the following:
 - a. Preparation of record documents.
 - b. Procedures required prior to inspection for Substantial Completion and for final inspection for acceptance.
 - c. Submittal of written warranties.
 - d. Requirements for preparing operations and maintenance data.
 - e. Requirements for demonstration and training.

- f. Preparation of Contractor's punch list.
 - g. Procedures for processing Applications for Payment at Substantial Completion and for final payment.
 - h. Submittal procedures.
 - i. Owner's phased occupancy requirements.
 - j. Installation of Owner's furniture, fixtures, and equipment.
 - k. Responsibility for removing temporary facilities and controls.
4. Minutes: Entity conducting meeting will record and distribute meeting minutes.
- E. Progress Meetings: Owner will conduct progress meetings at regular intervals.
1. Coordinate dates of meetings with preparation of payment requests.
 2. Attendees: In addition to representatives of Owner, Contractor, and Architect, each contractor, subcontractor, supplier, and other entity concerned with current progress or involved in planning, coordination, or performance of future activities shall be represented at these meetings. All participants at the meeting shall be familiar with Project and authorized to conclude matters relating to the Work.
 3. Agenda: Review and correct or approve minutes of previous progress meeting. Review other items of significance that could affect progress. Include topics for discussion as appropriate to status of Project.
 - a. Contractor's Construction Schedule: Review progress since the last meeting. Determine whether each activity is on time, ahead of schedule, or behind schedule, in relation to Contractor's construction schedule. Determine how construction behind schedule will be expedited; secure commitments from parties involved to do so. Discuss whether schedule revisions are required to ensure that current and subsequent activities will be completed within the Contract Time.
 - 1) Review schedule for next period.
 - b. Review present and future needs of each entity present, including the following:
 - 1) Interface requirements.
 - 2) Sequence of operations.
 - 3) Status of submittals.
 - 4) Deliveries.
 - 5) Off-site fabrication.
 - 6) Access.
 - 7) Site utilization.
 - 8) Temporary facilities and controls.
 - 9) Progress cleaning.
 - 10) Quality and work standards.
 - 11) Status of correction of deficient items.
 - 12) Field observations.
 - 13) Status of RFIs.
 - 14) Status of proposal requests.
 - 15) Pending changes.

- 16) Status of Change Orders.
 - 17) Pending claims and disputes.
 - 18) Documentation of information for payment requests.
4. Minutes: Entity responsible for conducting the meeting will record and distribute the meeting minutes to each party present and to parties requiring information.
 - a. Schedule Updating: Revise Contractor's construction schedule after each progress meeting where revisions to the schedule have been made or recognized. Issue revised schedule concurrently with the report of each meeting.
- F. Coordination Meetings: Conduct Project coordination meetings at regular intervals. Project coordination meetings are in addition to specific meetings held for other purposes, such as progress meetings and pre-installation conferences.
1. Attendees: In addition to representatives of Owner, and Architect, each contractor, subcontractor, supplier, and other entity concerned with current progress or involved in planning, coordination, or performance of future activities shall be represented at these meetings. All participants at the meetings shall be familiar with Project and authorized to conclude matters relating to the Work.
 2. Agenda: Review and correct or approve minutes of the previous coordination meeting. Review other items of significance that could affect progress. Include topics for discussion as appropriate to status of Project.
 - a. Combined Contractor's Construction Schedule: Review progress since the last coordination meeting. Determine whether each contract is on time, ahead of schedule, or behind schedule, in relation to combined Contractor's construction schedule. Determine how construction behind schedule will be expedited; secure commitments from parties involved to do so. Discuss whether schedule revisions are required to ensure that current and subsequent activities will be completed within the Contract Time.
 - b. Schedule Updating: Revise combined Contractor's construction schedule after each coordination meeting where revisions to the schedule have been made or recognized. Issue revised schedule concurrently with report of each meeting.
 - c. Review present and future needs of each contractor present, including the following:
 - 1) Interface requirements.
 - 2) Sequence of operations.
 - 3) Status of submittals.
 - 4) Deliveries.
 - 5) Off-site fabrication.
 - 6) Access.
 - 7) Site utilization.
 - 8) Temporary facilities and controls.
 - 9) Work hours.
 - 10) Hazards and risks.

- 11) Progress cleaning.
 - 12) Quality and work standards.
 - 13) Change Orders.
3. Reporting: Record meeting results and distribute copies to everyone in attendance and to others affected by decisions or actions resulting from each meeting.

PART 2 - PRODUCTS (Not Used)

PART 3 - EXECUTION (Not Used)

END OF SECTION 013100

SECTION 013200 - CONSTRUCTION PROGRESS DOCUMENTATION

PART 1 - GENERAL

1.1 RELATED DOCUMENTS

- A. Drawings and general provisions of the Contract, including General and Supplementary Conditions and other Division 01 Specification Sections, apply to this Section.

1.2 SUMMARY

- A. Section includes administrative and procedural requirements for documenting the progress of construction during performance of the Work, including the following:
 - 1. Start-up construction schedule.
 - 2. Contractor's construction schedule.
 - 3. Daily construction reports.
 - 4. Material location reports.
 - 5. Field condition reports.
 - 6. Cost loading and cash flow schedule.
 - 7. Manpower histogram.
 - 8. Material status report.
 - 9. Construction equipment report.
 - 10. Special reports.
- B. Related Sections:
 - 1. Division 01 Section "Submittal Procedures" for submitting schedules and reports.

1.3 DEFINITIONS

- A. Activity: A discrete part of a project that can be identified for planning, scheduling, monitoring, and controlling the construction project. Activities included in a construction schedule consume time and resources.
 - 1. Critical Activity: An activity on the critical path that must start and finish on the planned early start and finish times.
 - 2. Predecessor Activity: An activity that precedes another activity in the network.
 - 3. Successor Activity: An activity that follows another activity in the network.
- B. Cost Loading: The allocation of the schedule of values for the completion of an activity as scheduled. The sum of costs for all activities must equal the total Contract Sum, unless otherwise approved by Architect.

- C. CPM: Critical path method, which is a method of planning and scheduling a construction project where activities are arranged based on activity relationships. Network calculations determine when activities can be performed and the critical path of the Project.
- D. Critical Path: The longest connected chain of interdependent activities through the network schedule that establishes the minimum overall Project duration and contains no float.
- E. Event: The starting or ending point of an activity.
- F. Float: The measure of leeway in starting and completing an activity.
 - 1. Float time is not for the exclusive use or benefit of either Owner or Contractor, but is a jointly owned, expiring Project resource available to both parties as needed to meet schedule milestones and Contract completion date.
 - a. Extensions of time for performance required under General Conditions pertaining to equitable time adjustment will be granted only to extent that equitable time adjustment exceeds total float in activity or path of activities affected at time Notice to Proceed was issued for change.
 - b. Use of float suppression techniques such as preferential sequencing or logic, special lead/lag logic restraint, extended activity times or imposed dates shall be cause for rejection of Contractor's Construction Schedule and revisions or updates. Use of float time disclosed or implied by use of alternative float suppression techniques shall be shared as directed by Construction Manager to proportionate benefit of Owner and Contractor.
 - 2. Free float is the amount of time an activity can be delayed without adversely affecting the early start of the successor activity.
 - 3. Total float is the measure of leeway in starting or completing an activity without adversely affecting the planned Project completion date.
- G. Fragnet: A partial or fragmentary network that breaks down activities into smaller activities for greater detail.
- H. Major Area: A story of construction, a separate building, or a similar significant construction element.
- I. Major Subcontractor: For purposes of this Section, major subcontractor is defined as subcontractor or supplier whose subcontract value equals or exceeds 10 percent of value of Contract.
- J. Milestone: A key or critical point in time for reference or measurement.
- K. Network Diagram: A graphic diagram of a network schedule, showing activities and activity relationships.
- L. Resource Loading: The allocation of manpower and equipment necessary for the completion of an activity as scheduled.

1.4 INFORMATIONAL SUBMITTALS

- A. Format for Submittals: Submit required submittals in the following format:
 - 1. PDF electronic file.
 - 2. Five paper copies.
- B. Submittals Schedule: Submit per Division 01 Section "Submittals Procedures."
- C. Start-up construction schedule.
 - 1. Approval of cost-loaded start-up construction schedule will not constitute approval of schedule of values for cost-loaded activities.
- D. Start-up Network Diagram: Of size required to display entire network for entire construction period. Show logic ties for activities.
- E. Contractor's Construction Schedule: Initial schedule, of size required to display entire schedule for entire construction period.
 - 1. Submit a working electronic copy of schedule, using software indicated, and labeled to comply with requirements for submittals. Include type of schedule (initial or updated) and date on label.
- F. CPM Reports: Concurrent with CPM schedule, submit each of the following reports. Format for each activity in reports shall contain activity number, activity description, cost and resource loading, original duration, remaining duration, early start date, early finish date, late start date, late finish date, and total float in calendar days.
 - 1. Activity Report: List of all activities sorted by activity number and then early start date, or actual start date if known.
 - 2. Logic Report: List of preceding and succeeding activities for all activities, sorted in ascending order by activity number and then early start date, or actual start date if known.
 - 3. Total Float Report: List of all activities sorted in ascending order of total float.
 - 4. Earnings Report: Compilation of Contractor's total earnings from the Notice to Proceed until most recent Application for Payment.
- G. Daily Construction Reports: Submit at weekly intervals.
- H. Field Condition Reports: Submit at time of discovery of differing conditions.
- I. Cost Loading and Cash Flow Schedule: Submit five copies with initial submittal and each update of Contractor's Construction Schedule.
- J. Manpower Histogram: Submit five copies with initial submittal and each update of Contractor's Construction Schedule.
- K. Material Status Report: Submit five copies with initial submittal and each update of Contractor's Construction Schedule.

- L. Construction Equipment Report: Submit five copies with initial submittal and each update of Contractor's Construction Schedule.
- M. Special Reports: Submit at time of unusual event.
- N. Qualification Data: For scheduling consultant.

1.5 QUALITY ASSURANCE

- A. Contractor's Construction Scheduler: Employ or retain services of construction scheduler with minimum 5 years experience as person primarily responsible for preparing and maintaining detailed project schedules and capable of producing reports and diagrams within 24 hours of Construction Manager's request.
 - 1. Construction Scheduler shall be on Site as required for purpose of continuously monitoring, modifying, or updating Contractor's Construction Schedule.
 - 2. Construction Scheduler shall attend meetings pertaining to scheduling, progress of Work, and alleged delays and time impacts.
- B. Within 5 days after Notice of Award, provide statement to Construction Manager indicating following:
 - 1. Identification, qualifications, and experience of construction scheduler and other members of Contractor's scheduling staff.
 - 2. References for not less than 3 previous projects on which construction scheduler has utilized scheduling means similar to that required for this project with scheduling requirements equal to or exceeding scheduling requirements specified for this Project.
 - 3. Description of scheduling system to be utilized.
 - 4. Construction Manager reserves the right to disapprove construction scheduler, Contractor's scheduling staff, or scheduling system proposed for Project.
 - 5. Construction Manager reserves the right to remove from Project, construction scheduler and any member of Contractor's scheduling staff that is, in Construction Manager's opinion, incompetent in scheduling.
- C. Prescheduling Conference: Within 14 days after Notice of Award, Construction Manager will schedule and conduct Prescheduling Conference with Contractor, major subcontractors, Construction Scheduler, and Contractor's scheduling staff. Comply with requirements in Division 01 Section "Project Management and Coordination." Review methods and procedures related to Preliminary Construction Schedule and Contractor's Construction Schedule including but not limited to:
 - 1. Review and discuss methodology for schedule and sequence of operations.
 - 2. Review software limitations and content and format for reports.
 - 3. Verify availability of qualified personnel needed to develop and update schedule.
 - 4. Discuss constraints, including phasing, work stages, area separations, interim milestones, and partial Owner occupancy.
 - 5. Review delivery dates for Owner-furnished products.
 - 6. Review schedule for work of Owner's separate contracts.
 - 7. Review time required for review of submittals and resubmittals.

8. Review requirements for tests and inspections by independent testing and inspecting agencies.
9. Review time required for completion and startup procedures.
10. Review and finalize list of construction activities to be included in schedule.
11. Review submittal requirements and procedures.
12. Review procedures for updating schedule.

1.6 COORDINATION

- A. Coordinate preparation and processing of schedules and reports with performance of construction activities and with scheduling and reporting of separate contractors.
- B. Coordinate Contractor's construction schedule with the schedule of values, submittal schedule, progress reports, payment requests, and other required schedules and reports.
 1. Secure time commitments for performing critical elements of the Work from entities involved.
 2. Coordinate each construction activity in the network with other activities and schedule them in proper sequence.

PART 2 - PRODUCTS

2.1 CONTRACTOR'S CONSTRUCTION SCHEDULE, GENERAL

- A. Time of beginning, rate of progress, and date of completion of Work are of essence of this Contract. Work shall be executed with such progress as required to prevent delay to other contractors working on other contracts at Site, if any, Contract milestones, or general completion of Contract.
- B. Responsibility for completion:
 1. Should any activity fail to be completed within 15 days of indicated schedule date, take steps necessary to improve progress at no additional cost to Owner including, but not limited to:
 - a. Increase number of working hours per shift, shifts per working day, working days per week, or amount of construction equipment, or any combination of foregoing, sufficiently to substantially eliminate lag in scheduled progress.
 - b. Reschedule sequence of activities to achieve maximum practical concurrent accomplishment of Work activities.
 2. Construction Manager may require Contractor to submit for Construction Manager's approval, at no additional cost to Owner, such supplementary progress schedules as may be deemed necessary to demonstrate manner in which progress schedule will be regained.
 3. Failure to comply with specified corrective measures shall be grounds for determination by Construction Manager that Contractor is not prosecuting Work

with such diligence as will ensure completion within time specified and may result in termination of Contractor's right to proceed with Work, or any separable part thereof, in accordance with applicable provisions of General Conditions.

- C. Failure to include any element of Work required for performance of Contract shall not excuse Contractor from completing all Work required within applicable time constraints, notwithstanding Construction Manager's approval of Contractor's Construction Schedule.
- D. Nothing in these requirements shall be deemed to negate or diminish Contractor's authority and responsibility to plan and schedule Work as required, subject to requirements of Contract Documents.
- E. Procedures: Comply with procedures contained in AGC's "Construction Project Planning & Scheduling Guidelines," latest edition.
 - 1. To extent there are conflicts between AGC's publication and Specifications, Specifications shall govern.
- F. Time Frame: Extend schedule from date established for the Notice to Proceed to date of final completion.
 - 1. Contract completion date shall not be changed by submission of a schedule that shows an early completion date, unless specifically authorized by Change Order.
 - 2. If Contractor submits Contractor's Construction Schedule showing completion of Work more than 30 work days in advance of Contract Completion Date, Construction Manager may, at no cost to Owner, decrease Contract Time by issuance of Change Order which will change appropriate milestone dates and Contract Completion date to completion date reflected on Contractor's Construction Schedule.
 - 3. Schedule updates having early completion date shall show time between early completion date and Contract Completion Date as activity labeled "project float."
- G. Activities: Treat each story or separate area as a separate numbered activity for each principal element of the Work. Comply with the following:
 - 1. No activity shall be less than 1 day duration. Exceptions may be approved by Construction Manager when subnetworks can be issued.
 - 2. Procurement Activities: Include procurement process activities for the following long lead items and major items, requiring a cycle of more than 60 days, as separate activities in schedule. Procurement cycle activities include, but are not limited to, submittals, approvals, purchasing, fabrication, and delivery.
 - a. Doors and Locking Devices
 - b. Security Control Systems
 - 3. Submittal Review Time: Include review and resubmittal times indicated in Division 01 Section "Submittal Procedures" in schedule. Coordinate submittal review times in Contractor's construction schedule with submittal schedule.
 - 4. Startup and Testing Time: Include not less than 15 days for startup and testing.

5. Substantial Completion: Indicate completion in advance of date established for Substantial Completion, and allow time for Construction Manager's administrative procedures necessary for certification of Substantial Completion.
 6. Punch List and Final Completion: Include not more than 30 days for punch list and final completion.
- H. Constraints: Include constraints and work restrictions indicated in the Contract Documents and as follows in schedule, and show how the sequence of the Work is affected.
1. Phasing: Arrange list of activities on schedule by phase.
 2. Owner-Furnished Products: Include a separate activity for each product. Include delivery date indicated in Division 01 Section "Summary." Delivery dates indicated stipulate the earliest possible delivery date.
 3. Work Restrictions: Show the effect of the following items on the schedule:
 - a. Coordination with existing construction.
 - b. Limitations of continued occupancies.
 - c. Uninterruptible services.
 - d. Partial occupancy before Substantial Completion.
 - e. Use of premises restrictions.
 - f. Provisions for future construction.
 - g. Seasonal variations.
 - h. Environmental control.
 4. Work Stages: Indicate important stages of construction for each major portion of the Work, including, but not limited to, the following:
 - a. Subcontract awards.
 - b. Submittals.
 - c. Purchases.
 - d. Mockups.
 - e. Fabrication.
 - f. Sample testing.
 - g. Deliveries.
 - h. Installation.
 - i. Tests and inspections.
 - j. Adjusting.
 - k. Curing.
 - l. Startup and placement into final use and operation.
 5. Construction Areas: Identify each major area of construction for each major portion of the Work. Indicate where each construction activity within a major area must be sequenced or integrated with other construction activities to provide for the following:
 - a. Selective Demolition
 - b. Completion of door and locking system installation.
 - c. Completion of electrical and security control system installation.
 - d. Substantial Completion.

- I. Milestones: Include milestones indicated in the Contract Documents in schedule, including, but not limited to, the Notice to Proceed, Substantial Completion, and final completion by Phase.
- J. Cost Correlation: At the head of schedule, provide a cost correlation line, indicating planned and actual costs. On the line, show dollar volume of the Work performed as of dates used for preparation of payment requests.
 1. Refer to Division 01 Section "Payment Procedures" for cost reporting and payment procedures.
 2. Contractor shall assign cost to construction activities on the CPM schedule. Costs shall not be assigned to submittal activities unless specified otherwise but may, with Architect's approval, be assigned to fabrication and delivery activities. Costs shall be under required principal subcontracts for testing and commissioning activities, operation and maintenance manuals, punch list activities, Project Record Documents, and demonstration and training (if applicable), in the amount of 5 percent of the Contract Sum.
 3. Each activity cost shall reflect an accurate value subject to approval by Architect.
 4. Total cost assigned to activities shall equal the total Contract Sum.
- K. Upcoming Work Summary: Prepare summary report indicating activities scheduled to occur or commence prior to submittal of next schedule update. Summarize the following issues:
 1. Unresolved issues.
 2. Unanswered RFIs.
 3. Rejected or unreturned submittals.
 4. Notations on returned submittals.
- L. Recovery Schedule: When periodic update indicates the Work is 14 or more calendar days behind the current approved schedule, submit a separate recovery schedule indicating means by which Contractor intends to regain compliance with the schedule. Indicate changes to working hours, working days, crew sizes, and equipment required to achieve compliance, and the date by which recovery will be accomplished.
- M. Computer Scheduling Software: Prepare schedules using current version of a program that has been developed specifically to manage construction schedules.
 1. System shall be capable of handling, processing, printing, and plotting data to satisfy requirements of this Section.
 2. Subject to compliance with requirements, use Primavera Project Planner, Version P3 for Windows XP or equivalent scheduling program acceptable to Construction Manager. Use latest version or earlier version acceptable to Owner.
 3. System shall be capable of producing computer generated reports with following minimum information:
 - a. Activity identification code keyed to Summary Schedule activities.
 - b. Activity number and activity description.
 - c. From date of report, remaining working days left until early finish of each activity.

-
- d. Activity percent complete.
 - e. Activity duration.
 - f. Early start/finish and late start/finish.
 - g. Actual start date/finish date.
 - h. Total float.
 - i. Free float.
 - j. Predecessor and successor activities for each individual activity including precedence logic relationships.
 - k. Comparison between current update and baseline schedule.
 - l. Critical Item List of activities with 15 days or less total float.
 - m. Scheduled and actual labor for each activity.
 - n. Scheduled and actual progress payment for each activity.
- 4. Use logic retain methodology at all times for schedule and float calculation.
 - 5. Software shall be capable of compiling total dollar value of complete and partially complete activities.
 - 6. Software shall be capable of accepting revised completion dates, as modified by approved time extensions, and re-computing activity dates and float accordingly.
- N. Use hardware system commensurate with size of Project, subject to Construction Manager's approval.

2.2 PRELIMINARY CONSTRUCTION SCHEDULE

- A. Prepare Preliminary Construction Schedule covering first 90 days following Notice to Proceed as well as skeleton network diagram for remainder of Work.
- 1. Show work tasks that will or may affect completion dates including, but not limited to:
 - a. Planning.
 - b. Mobilization.
 - c. Key shop drawing and sample submittals.
 - d. Fabrication and delivery of key and long-lead procurement elements.
 - e. Activities of Owner, other contractors, utilities, tenants, or other third parties.
- B. Concurrent with and as part of Preliminary Construction Schedule, submit schedule of manpower and costs assigned to each activity on Preliminary Construction Schedule.
- 1. Costs assigned shall conform to bid item unit prices, and lump sum bid item breakdown acceptable to Construction Manager.
 - 2. Schedule of manpower and costs shall be realistic and level so as to not have any unusual manpower requirements.
- C. Submit to Construction Manager within 14 days after Prescheduling Conference.
- D. Meet with Construction Manager within 7 days after submittal to review and make necessary adjustments or revisions.

- E. Submit revised Preliminary Construction Schedule within 7 days after meeting for Construction Manager's approval.
- F. Revised Preliminary Construction Schedule represents Contractor's planned means, methods, and sequences for performance of Work during specified period and shall be incorporated into Contractor's Construction Schedule.
- G. No Work shall be performed prior to submittal and Construction Manager's approval of preliminary project schedule, including manpower and cost reports.
 - 1. Submittal and Construction Manager's approval of preliminary project schedule, including manpower and cost reports and other appropriate reports and network diagrams subsequently specified in article titled "Contractor's Construction Schedule as required by Construction Manager, is a condition precedent to issuance and payment of initial Application for Payment.
- H. Update schedule monthly during specified period, as part of payment application process.
 - 1. Submit appropriate reports and network diagrams as required by Construction Manager.

2.3 CONTRACTOR'S CONSTRUCTION SCHEDULE (CPM SCHEDULE)

- A. Submittal Requirements:
 - 1. Fifteen days after submittal of revised Preliminary Construction Schedule, meet with Construction Manager to review progress in development of summary schedule and Contractor's Construction Schedule.
 - 2. Submit Contractor's Construction Schedule within 30 days after submittal of revised Preliminary Construction Schedule.
 - 3. Meet with Construction Manager] within 7 days after submittal to review and make necessary adjustments or revisions.
 - a. Comments made by Construction Manager will not relieve Contractor from compliance with requirements of Contract Documents.
 - 4. Submit revised Contractor's Construction Schedule within 7 days after meeting for Construction Manager's approval.
- B. To the extent that there are conflicts between detailed project schedule and requirements of Contract Documents, Contract Documents govern.
- C. General: Prepare network diagrams using AON (activity-on-node) format.
- D. Include revised Preliminary Construction Schedule intact as inherent part of Contractor's Construction Schedule.
- E. CPM Schedule: Prepare Contractor's Construction Schedule using a computerized, cost- and resource-loaded, time-scaled CPM network analysis diagram for the Work.

1. Develop network diagram to submit CPM schedule so it can be accepted for use in sufficient time to provide seamless transition from Preliminary Construction Schedule to Contractor's Construction Schedule
 - a. Failure to include any work item required for performance of this Contract shall not excuse Contractor from completing all work within applicable completion dates, regardless of Construction Manager's approval of the schedule.
 2. Conduct educational workshops to train and inform key Project personnel, including subcontractors' personnel, in proper methods of providing data and using CPM schedule information.
 3. Establish procedures for monitoring and updating CPM schedule and for reporting progress. Coordinate procedures with progress meeting and payment request dates.
 4. Use "one workday" as the unit of time. Include list of nonworking days and holidays incorporated into the schedule.
- F. Activities in Contractor's Construction Schedule shall be grouped to enable "rollup" to activities in summary schedule.
1. Summary schedule shall be in bar chart format, time scaled in calendar days from Notice to Proceed, with critical path identified.
 2. Summary schedule shall clearly delineate construction activities for each phase and summary schedule shall contain, but is not limited to:
 - a. Legend of scheduled activities based on early start/finish.
 - b. Owner's and Contractor's scheduled milestones.
 - c. Scheduled summary activities shall clearly indicate scope of Work to be completed.
 - d. Submit summary schedule as required for Contractor's Construction Schedule.
- G. CPM Schedule Preparation: Prepare a list of all activities required to complete the Work. Using the preliminary network diagram, prepare a skeleton network to identify probable critical paths.
1. Activities: Indicate the estimated time duration, sequence requirements, and relationship of each activity in relation to other activities. Include estimated time frames for the following activities:
 - a. Mobilization and demobilization.
 - b. Temporary construction support installations.
 - c. Demolition and removals.
 - d. Coordination with other contractors under separate contract with Owner, tenants, utilities, and work by others adjacent to Work of this Contract.
 - e. Submittal preparation and review.
 - f. Order, manufacture, delivery, tests, and installation of critical material and major components, including material to be furnished by Owner for installation by Contractor.
 - g. Other major construction activities.

-
- h. Resource loading for cost, manpower, material, and equipment.
 - i. Allowance for inclement weather and similar conditions.
 - j. Approvals and notices required by regulatory agencies and other third parties.
 - k. Punch-out and acceptance of Work including start-up, testing, and inspection.
 - l. Limits imposed by scope of Work, with contractually specified intermediate milestone and completion dates, and with constraints, restraints, or sequences included in Contract.
 - m. Final clean-up.
 - n. Planning for phased or total takeover by Owner.
 - 2. Critical Path Activities: Identify critical path activities, including those for interim completion dates. Scheduled start and completion dates shall be consistent with Contract milestone dates.
 - 3. Processing: Process data to produce output data on a computer-drawn, time-scaled network. Revise data, reorganize activity sequences, and reproduce as often as necessary to produce the CPM schedule within the limitations of the Contract Time.
 - 4. Format: Mark the critical path. Locate the critical path near center of network; locate paths with most float near the edges.
 - a. Subnetworks on separate sheets are permissible for activities clearly off the critical path.
 - H. Initial Issue of Schedule: Prepare initial network diagram from a list of straight "early start-total float" sort. Identify critical activities. Prepare tabulated reports showing the following:
 - 1. Contractor or subcontractor and the Work or activity.
 - 2. Description of activity.
 - 3. Principal events of activity.
 - 4. Immediate preceding and succeeding activities.
 - 5. Early and late start dates.
 - 6. Early and late finish dates.
 - 7. Activity duration in workdays.
 - 8. Total float or slack time.
 - 9. Average size of workforce.
 - 10. Dollar value of activity (coordinated with the Schedule of Values).
 - 11. Sublisting of materials and equipment sorted by specification section number. Sublisting of materials and equipment shall include following activities.
 - a. Preparation of shop drawings and submittal to Construction Manager.
 - b. Fabrication, testing, and delivery of material and equipment which shall be interfaced with earliest start date that material or equipment is to be installed on Project.
 - I. Schedule Updating: Concurrent with making revisions to schedule, prepare tabulated reports showing the following:
 - 1. Identification of activities that have changed.

2. Changes in early and late start dates.
3. Changes in early and late finish dates.
4. Changes in activity durations in workdays.
5. Changes in the critical path.
6. Changes in total float or slack time.
7. Changes in the Contract Time.

J. Value Summaries: Prepare two cumulative value lists, sorted by finish dates.

1. In first list, tabulate activity number, early finish date, dollar value, and cumulative dollar value.
2. In second list, tabulate activity number, late finish date, dollar value, and cumulative dollar value.
3. In subsequent issues of both lists, substitute actual finish dates for activities completed as of list date.
4. Prepare list for ease of comparison with payment requests; coordinate timing with progress meetings.
 - a. In both value summary lists, tabulate "actual percent complete" and "cumulative value completed" with total at bottom.
 - b. Submit value summary printouts one week before each regularly scheduled progress meeting.

K. Cost Loading and Cash Flow Schedule:

1. Submit payment request for each month with proposed updates as well as cumulative payment requests to date for each month of Project.
 - a. Show net payment request for each month and cumulative payment Requests to date after deducting retainage and other monies withheld.

2.4 SHORT INTERVAL SCHEDULE

A. Once each week, on date established by Construction Manager, submit following:

1. Short interval schedule derived directly from Contractor's Construction Schedule, in form of bar chart showing activities completed and in progress for previous week and activities scheduled for succeeding 2 weeks.
2. Schedule listing activities completed by activity designation from Contractor's Construction Schedule and in progress for previous week and activities scheduled for succeeding 4 weeks.
 - a. Include Work which affects Site operations, utilities, equipment, and like detail as well as access alterations.

2.5 AS BUILT SCHEDULE

- A. As a condition precedent to release of retention, last update to Contractor's Construction Schedule shall be identified as "As Built Schedule" and shall reflect exact manner in which project was actually constructed, including start and completion dates, activities, sequences, and logic.

1. As built schedule shall be signed and certified by Contractor and construction scheduler as being true reflection of manner in which Project was actually constructed.

2.6 REPORTS

A. Daily Construction Reports: Prepare a daily construction report recording the following information concerning events at Project site:

1. List of subcontractors at Project site.
2. List of separate contractors at Project site.
3. Approximate count of personnel at Project site.
4. Equipment at Project site.
5. Material deliveries.
6. High and low temperatures and general weather conditions, including presence of rain or snow.
7. Accidents.
8. Meetings and significant decisions.
9. Unusual events (refer to special reports).
10. Stoppages, delays, shortages, and losses.
11. Meter readings and similar recordings.
12. Emergency procedures.
13. Orders and requests of authorities having jurisdiction.
14. Change Orders received and implemented.
15. Construction Change Directives received and implemented.
16. Services connected and disconnected.
17. Equipment or system tests and startups.
18. Partial completions and occupancies.
19. Substantial Completions authorized.

B. Field Condition Reports: Immediately on discovery of a difference between field conditions and the Contract Documents, prepare and submit a detailed report. Submit with a Request for Information. Include a detailed description of the differing conditions, together with recommendations for changing the Contract Documents.

C. Cost Loading and Cash Flow Schedule:

1. With initial detailed project schedule submittal and each update, submit schedule of cost loading and cash flow.
 - a. Each individual activity within detailed project schedule shall employ code which, in summary, attaches its cost, if any, to appropriate bid items.
 - b. Sum of activity costs within specific code shall equal cost of corresponding bid items and approved Change Orders.
2. Submit payment request for each month with proposed updates as well as cumulative payment requests to date for each month of Project.
 - a. Show net payment request for each month and cumulative payment requests to date after deducting retainage and other monies withheld.

- b. Show cash flow in tabular and graphic format.
- D. Manpower Histogram: With initial detailed project schedule and each update, submit histogram depicting total project craft manpower and craft manpower for own forces and forces of each subcontractor for each month.
1. Histogram shall be based on and be in substantive agreement with number of shifts and crew sizes by craft in Contractor's Construction Schedule.
 2. Show actual manpower for each month during construction period to date and required manpower for both base scope and Change Order Work each month necessary to complete remaining activities, including Change Order Work, to ensure timely project completion.
- E. Material Status Report:
1. With initial detailed project schedule and each update, submit material status report showing planned delivery of construction materials by activity grouped by phases that are required to maintain detailed project baseline schedule. Items shall include, but are not limited to:
 - a. Activity and description of type of materials.
 - b. Total quantity required.
 - c. Required delivery schedule.
 - d. Scheduled order date.
 2. Updates shall show:
 - a. Actual order date.
 - b. Actual delivery to Site, date, and quantity.
 - c. Total quantity delivered to Site to date.
 - d. Remaining quantity to be delivered.
 - e. Estimated delivery date of remaining materials.
- F. Construction Equipment Report: With initial Contractor's Construction Schedule and each update, submit tabular report listing each major piece of Contractor's construction equipment and each major piece of construction equipment for each subcontractor for each month.
1. Describe each major piece of equipment separately, identified and numbered in report.
 2. Tabular report shall be based upon and in substantive agreement with number of shifts and crew sizes by craft in Contractor's Construction Schedule.
 3. Updates shall show actual construction equipment for each month during construction period to date and required construction equipment for each month necessary to complete remaining activities, including Change Order Work, on early finish date.

2.7 SPECIAL REPORTS

- A. General: Submit special reports directly to Construction Manager within one day of an occurrence. Distribute copies of report to parties affected by the occurrence.
- B. Reporting Unusual Events: When an event of an unusual and significant nature occurs at Project site, whether or not related directly to the Work, prepare and submit a special report. List chain of events, persons participating, response by Contractor's personnel, evaluation of results or effects, and similar pertinent information. Advise Owner in advance when these events are known or predictable.

PART 3 - EXECUTION

3.1 CONTRACTOR'S CONSTRUCTION SCHEDULE

- A. Contractor's Construction Schedule Updating: At monthly intervals, update schedule to reflect actual construction progress and activities. Issue schedule one week before each regularly scheduled progress meeting.
 - 1. Revise schedule immediately after each meeting or other activity where revisions have been recognized or made. Issue updated schedule concurrently with the report of each such meeting.
 - 2. Include a report with updated schedule that indicates every change, including, but not limited to, changes in logic, durations, actual starts and finishes, and activity durations.
 - 3. As the Work progresses, indicate final completion percentage for each activity.
- B. Distribution: Distribute copies of approved schedule to Construction Manager, Owner, separate contractors, testing and inspecting agencies, and other parties identified by Contractor with a need-to-know schedule responsibility.
 - 1. Post copies in Project meeting rooms and temporary field offices.
 - 2. When revisions are made, distribute updated schedules to the same parties and post in the same locations. Delete parties from distribution when they have completed their assigned portion of the Work and are no longer involved in performance of construction activities.

END OF SECTION 013200

SECTION 013300 - SUBMITTAL PROCEDURES

PART 1 - GENERAL

1.1 RELATED DOCUMENTS

- A. Drawings and general provisions of the Contract, including General and Supplementary Conditions and other Division 01 Specification Sections, apply to this Section.

1.2 SUMMARY

- A. This Section includes administrative and procedural requirements for submitting Shop Drawings, Product Data, Samples, and other submittals.
- B. Related Requirements:
 - 1. Section 013100 "Project Management and Coordination" for submitting coordination drawings and subcontract list and for requirements for web-based Project software.
 - 2. Section 013200 "Construction Progress Documentation" for submitting schedules and reports, including Contractor's construction schedule.
 - 3. Section 014000 "Quality Requirements" for submitting test and inspection reports, and schedule of tests and inspections.
 - 4. Section 017700 "Closeout Procedures" for submitting closeout submittals and maintenance material submittals.
 - 5. Section 017823 "Operation and Maintenance Data" for submitting operation and maintenance manuals.
 - 6. Section 017839 "Project Record Documents" for submitting record Drawings, record Specifications, and record Product Data.

1.3 DEFINITIONS

- A. Action Submittals: Written and graphic information that requires Architect's responsive action. Action submittals are those submittals indicated in individual Specification Sections as "action submittals."
- B. Informational Submittals: Written information that does not require Architect's responsive action. Submittals may be rejected for not complying with requirements. Informational submittals are those submittals indicated in individual Specification Sections as "informational submittals."

1.4 SUBMITTAL SCHEDULE

- A. Submittal Schedule: Submit, as an action submittal, a list of submittals, arranged in chronological order by dates required by construction schedule. Include time required for review, ordering, manufacturing, fabrication, and delivery when establishing dates. Include additional time required for making corrections or revisions to submittals noted by Architect and additional time for handling and reviewing submittals required by those corrections.
1. Coordinate submittal schedule with list of subcontracts, the schedule of values, and Contractor's construction schedule.
 2. Initial Submittal: Submit concurrently with startup construction schedule. Include submittals required during the first 60 days of construction. List those submittals required to maintain orderly progress of the Work and those required early because of long lead time for manufacture or fabrication.
 3. Final Submittal: Submit concurrently with the first complete submittal of Contractor's construction schedule.
 - a. Submit revised submittal schedule to reflect changes in current status and timing for submittals.
 4. Format: Arrange the following information in a tabular format:
 - a. Scheduled date for first submittal.
 - b. Specification Section number and title.
 - c. Submittal Category: Action; informational.
 - d. Name of subcontractor.
 - e. Description of the Work covered.
 - f. Scheduled date for Architect's final release or approval.
 - g. Scheduled dates for purchasing.
 - h. Scheduled date of fabrication.
 - i. Scheduled dates for installation.
 - j. Activity or event number.

1.5 SUBMITTAL FORMATS

- A. Submittal Information: Include the following information in each submittal:
1. Project name.
 2. Date.
 3. Name of Architect.
 4. Name of Construction Manager.
 5. Name of Contractor.
 6. Name of firm or entity that prepared submittal.
 7. Names of subcontractor, manufacturer, and supplier.
 8. Unique submittal number, including revision identifier. Include Specification Section number with sequential alphanumeric identifier; and alphanumeric suffix for resubmittals.
 9. Category and type of submittal.

10. Submittal purpose and description.
 11. Number and title of Specification Section, with paragraph number and generic name for each of multiple items.
 12. Drawing number and detail references, as appropriate.
 13. Indication of full or partial submittal.
 14. Location(s) where product is to be installed, as appropriate.
 15. Other necessary identification.
 16. Remarks.
 17. Signature of transmitter.
- B. Options: Identify options requiring selection by Architect.
- C. Deviations and Additional Information: On each submittal, clearly indicate deviations from requirements in the Contract Documents, including minor variations and limitations; include relevant additional information and revisions, other than those requested by Architect on previous submittals. Indicate by highlighting on each submittal or noting on attached separate sheet.
- D. Paper Submittals:
1. Place a permanent label or title block on each submittal item for identification; include name of firm or entity that prepared submittal.
 2. Provide a space approximately 6 by 8 inches (150 by 200 mm) on label or beside title block to record Contractor's review and approval markings and action taken by Architect.
 3. Action Submittals: Submit three paper copies of each submittal unless otherwise indicated. Architect will return two copies.
 4. Informational Submittals: Submit two paper copies of each submittal unless otherwise indicated. Architect will not return copies.
 5. Additional Copies: Unless additional copies are required for final submittal, and unless Architect observes noncompliance with provisions in the Contract Documents, initial submittal may serve as final submittal.
 6. Transmittal for Submittals: Assemble each submittal individually and appropriately for transmittal and handling. Transmit each submittal using AIA Document G810 transmittal form.
- E. PDF Submittals: Prepare submittals as PDF package, incorporating complete information into each PDF file. Name PDF file with submittal number.
- F. Submittals for Web-Based Project Software: Prepare submittals as PDF files, or other format indicated by Project software website.
- 1.6 SUBMITTAL PROCEDURES
- A. Prepare and submit submittals required by individual Specification Sections. Types of submittals are indicated in individual Specification Sections.

1. Web-Based Project Software: Prepare submittals in PDF form, and upload to web-based Project software website. Enter required data in web-based software site to fully identify submittal.
 2. Paper: Prepare submittals in paper form, and deliver to Architect.
- B. Coordination: Coordinate preparation and processing of submittals with performance of construction activities.
1. Coordinate each submittal with fabrication, purchasing, testing, delivery, other submittals, and related activities that require sequential activity.
 2. Submit all submittal items required for each Specification Section concurrently unless partial submittals for portions of the Work are indicated on approved submittal schedule.
 3. Submit action submittals and informational submittals required by the same Specification Section as separate packages under separate transmittals.
 4. Coordinate transmittal of different types of submittals for related parts of the Work so processing will not be delayed because of need to review submittals concurrently for coordination.
 - a. Architect reserves the right to withhold action on a submittal requiring coordination with other submittals until related submittals are received.
- C. Submittals Schedule: Comply with requirements in Division 1 Section "Construction Progress Documentation" for list of submittals and time requirements for scheduled performance of related construction activities.
- D. Processing Time: Allow enough time for submittal review, including time for resubmittals, as follows. Time for review shall commence on Architect's receipt of submittal. No extension of the Contract Time will be authorized because of failure to transmit submittals enough in advance of the Work to permit processing, including resubmittals.
1. Initial Review: Allow 15 days for initial review of each submittal. Allow additional time if coordination with subsequent submittals is required. Architect will advise Contractor when a submittal being processed must be delayed for coordination.
 2. Intermediate Review: If intermediate submittal is necessary, process it in same manner as initial submittal.
 3. Resubmittal Review: Allow 15 days for review of each resubmittal.
- E. Identification: Place a permanent label or title block on each submittal for identification.
1. Indicate name of firm or entity that prepared each submittal on label or title block.
 2. Provide a space approximately 6 by 8 inches on label or beside title block to record Contractor's review and approval markings and action taken by Architect.
 3. Include the following information on label for processing and recording action taken:
 - a. Project name.
 - b. Date.
 - c. Name and address of Architect.

- d. Name and address of Contractor.
 - e. Name and address of subcontractor.
 - f. Name and address of supplier.
 - g. Name of manufacturer.
 - h. Submittal number or other unique identifier, including revision identifier.
 - 1) Submittal number shall use Specification Section number followed by a decimal point and then a sequential number (e.g., 06100.01). Resubmittals shall include an alphabetic suffix after another decimal point (e.g., 06100.01.A).
 - i. Number and title of appropriate Specification Section.
 - j. Drawing number and detail references, as appropriate.
 - k. Location(s) where product is to be installed, as appropriate.
 - l. Other necessary identification.
- F. Deviations: Highlight, encircle, or otherwise specifically identify deviations from the Contract Documents on submittals.
- G. Additional Copies: Unless additional copies are required for final submittal, and unless Architect observes noncompliance with provisions in the Contract Documents, initial submittal may serve as final submittal.
- 1. Additional copies submitted for maintenance manuals will not be marked with action taken and will be returned.
- H. Transmittal: Package each submittal individually and appropriately for transmittal and handling. Transmit each submittal using a transmittal form. Architect will return submittals, without review, received from sources other than Contractor.
- I. Resubmittals: Make resubmittals in same form and number of copies as initial submittal.
- 1. Note date and content of previous submittal.
 - 2. Note date and content of revision in label or title block and clearly indicate extent of revision.
 - 3. Resubmit submittals until they are marked "Reviewed".
- J. Distribution: Furnish copies of final submittals to manufacturers, subcontractors, suppliers, fabricators, installers, authorities having jurisdiction, and others as necessary for performance of construction activities. Show distribution on transmittal forms.
- K. Use for Construction: Use only final submittals with mark indicating "Reviewed" taken by Architect.

PART 2 - PRODUCTS

2.1 ACTION SUBMITTALS

- A. General: Prepare and submit Action Submittals required by individual Specification Sections.
- B. Product Data: Collect information into a single submittal for each element of construction and type of product or equipment.
 - 1. If information must be specially prepared for submittal because standard printed data are not suitable for use, submit as Shop Drawings, not as Product Data.
 - 2. Mark each copy of each submittal to show which products and options are applicable.
 - 3. Include the following information, as applicable:
 - a. Manufacturer's written recommendations.
 - b. Manufacturer's product specifications.
 - c. Manufacturer's installation instructions.
 - d. Manufacturer's catalog cuts.
 - e. Wiring diagrams showing factory-installed wiring.
 - f. Printed performance curves.
 - g. Operational range diagrams.
 - h. Compliance with specified referenced standards.
 - i. Testing by recognized testing agency.
 - j. Notation of coordination requirements.
 - k. Availability and delivery time information.
 - 4. Number of Copies: Submit five copies of Product Data, unless otherwise indicated. Architect will return four copies. Mark up and retain one returned copy as a Project Record Document.
- C. Shop Drawings: Prepare Project-specific information, drawn accurately to scale. Do not base Shop Drawings on reproductions of the Contract Documents or standard printed data.
 - 1. Preparation: Fully illustrate requirements in the Contract Documents. Include the following information, as applicable:
 - a. Dimensions.
 - b. Identification of products.
 - c. Fabrication and installation drawings.
 - d. Roughing-in and setting diagrams.
 - e. Wiring diagrams showing field-installed wiring, including power, signal, and control wiring.
 - f. Shopwork manufacturing instructions.
 - g. Templates and patterns.
 - h. Schedules.
 - i. Notation of coordination requirements.

- j. Notation of dimensions established by field measurement.
 - k. Relationship to adjoining construction clearly indicated.
 - l. Seal and signature of professional engineer if specified.
 - m. Wiring Diagrams: Differentiate between manufacturer-installed and field-installed wiring.
 2. Sheet Size: Except for templates, patterns, and similar full-size drawings, submit Shop Drawings on sheets at least 8-1/2 by 11 inches but no larger than 30 by 40 inches.
 3. Number of Copies: Submit two opaque (bond) copies of each submittal. Architect will return one copy.
- D. Samples: Submit Samples for review of kind, color, pattern, and texture for a check of these characteristics with other elements and for a comparison of these characteristics between submittal and actual component as delivered and installed.
1. Transmit Samples that contain multiple, related components such as accessories together in one submittal package.
 2. Identification: Attach label on unexposed side of Samples that includes the following:
 - a. Generic description of Sample.
 - b. Product name and name of manufacturer.
 - c. Sample source.
 - d. Number and title of appropriate Specification Section.
 3. Disposition: Maintain sets of approved Samples at Project site, available for quality-control comparisons throughout the course of construction activity. Sample sets may be used to determine final acceptance of construction associated with each set.
- E. Product Schedule or List: As required in individual Specification Sections, prepare a written summary indicating types of products required for the Work and their intended location. Include the following information in tabular form:
1. Type of product. Include unique identifier for each product indicated in the Contract Documents or assigned by Contractor if none is indicated.
 2. Manufacturer and product name, and model number if applicable.
 3. Number and name of room or space.
 4. Location within room or space.
 5. Number of Copies: Submit three copies of product schedule or list, unless otherwise indicated. Architect will return two copies.
- F. Qualification Data: Prepare written information that demonstrates capabilities and experience of firm or person. Include lists of completed projects with project names and addresses, contact information of architects and owners, and other information specified.
- G. Design Data: Prepare and submit written and graphic information indicating compliance with indicated performance and design criteria in individual Specification Sections.

Include list of assumptions and summary of loads. Include load diagrams if applicable. Provide name and version of software, if any, used for calculations. Number each page of submittal.

H. Certificates:

1. Certificates and Certifications Submittals: Submit a statement that includes signature of entity responsible for preparing certification. Certificates and certifications shall be signed by an officer or other individual authorized to sign documents on behalf of that entity. Provide a notarized signature where indicated.
2. Installer Certificates: Submit written statements on manufacturer's letterhead certifying that Installer complies with requirements in the Contract Documents and, where required, is authorized by manufacturer for this specific Project.
3. Manufacturer Certificates: Submit written statements on manufacturer's letterhead certifying that manufacturer complies with requirements in the Contract Documents. Include evidence of manufacturing experience where required.
4. Material Certificates: Submit written statements on manufacturer's letterhead certifying that material complies with requirements in the Contract Documents.
5. Product Certificates: Submit written statements on manufacturer's letterhead certifying that product complies with requirements in the Contract Documents.
6. Welding Certificates: Prepare written certification that welding procedures and personnel comply with requirements in the Contract Documents. Submit record of Welding Procedure Specification and Procedure Qualification Record on AWS forms. Include names of firms and personnel certified.

I. Test and Research Reports:

1. Compatibility Test Reports: Submit reports written by a qualified testing agency, on testing agency's standard form, indicating and interpreting results of compatibility tests performed before installation of product. Include written recommendations for primers and substrate preparation needed for adhesion.
2. Field Test Reports: Submit written reports indicating and interpreting results of field tests performed either during installation of product or after product is installed in its final location, for compliance with requirements in the Contract Documents.
3. Material Test Reports: Submit reports written by a qualified testing agency, on testing agency's standard form, indicating and interpreting test results of material for compliance with requirements in the Contract Documents.
4. Preconstruction Test Reports: Submit reports written by a qualified testing agency, on testing agency's standard form, indicating and interpreting results of tests performed before installation of product, for compliance with performance requirements in the Contract Documents.
5. Product Test Reports: Submit written reports indicating that current product produced by manufacturer complies with requirements in the Contract Documents. Base reports on evaluation of tests performed by manufacturer and witnessed by a qualified testing agency, or on comprehensive tests performed by a qualified testing agency.

6. Research Reports: Submit written evidence, from a model code organization acceptable to authorities having jurisdiction, that product complies with building code in effect for Project. Include the following information:
 - a. Name of evaluation organization.
 - b. Date of evaluation.
 - c. Time period when report is in effect.
 - d. Product and manufacturers' names.
 - e. Description of product.
 - f. Test procedures and results.
 - g. Limitations of use.
- J. Submittals Schedule: Comply with requirements specified in Division 1 Section "Construction Progress Documentation."
- K. Application for Payment: Comply with requirements specified in Division 1 Section "Payment Procedures."
- L. Schedule of Values: Comply with requirements specified in Division 1 Section "Payment Procedures."
- M. Subcontract List: Prepare a written summary identifying individuals or firms proposed for each portion of the Work, including those who are to furnish products or equipment fabricated to a special design. Refer to Owner Solicitation Documents for requirements.

2.2 DELEGATED DESIGN SERVICES

- A. Performance and Design Criteria: Where professional design services or certifications by a design professional are specifically required of Contractor by the Contract Documents, provide products and systems complying with specific performance and design criteria indicated.
 1. If criteria indicated are not sufficient to perform services or certification required, submit a written request for additional information to Architect.
- B. Delegated-Design Submittal: In addition to Shop Drawings, Product Data, and other required submittals, submit digitally signed PDF file and three copies of a statement, signed and sealed by the responsible design professional, for each product and system specifically assigned to Contractor to be designed or certified by a design professional.
 1. Indicate that products and systems comply with performance and design criteria in the Contract Documents. Include list of codes, loads, and other factors used in performing these services.

PART 3 - EXECUTION

3.1 CONTRACTOR'S REVIEW

- A. Review each submittal and check for coordination with other Work of the Contract and for compliance with the Contract Documents. Note corrections and field dimensions. Mark with approval stamp before submitting to Architect.
- B. Approval Stamp: Stamp each submittal with a uniform, approval stamp and indication in web-based Project software. Include Project name and location, submittal number, Specification Section title and number, name of reviewer, date of Contractor's approval, and statement certifying that submittal has been reviewed, checked, and approved for compliance with the Contract Documents.
 - 1. Architect will not review submittals received from Contractor that do not have Contractor's review and approval.

3.2 ARCHITECT'S ACTION

- A. General: Architect will not review submittals that do not bear Contractor's approval stamp and will return them without action.
- B. Action Submittals: Architect will review each submittal, make marks to indicate corrections or modifications required, and return it. Architect will stamp each submittal with an action stamp and will mark stamp appropriately to indicate action taken.
 - 1. PDF Submittals: Architect will indicate, via markup on each submittal, the appropriate action.
 - 2. Paper Submittals: Architect will stamp each submittal with an action stamp and will mark stamp appropriately to indicate action.
 - 3. Submittals by Web-Based Project Software: Architect will indicate, on Project software website, the appropriate action.
- C. Informational Submittals: Architect will review each submittal and will not return it, or will return it if it does not comply with requirements. Architect will forward each submittal to appropriate party.
- D. Partial submittals are not acceptable, will be considered nonresponsive, and will be returned without review.
- E. Submittals not required by the Contract Documents may not be reviewed and may be discarded.
- F. Incomplete submittals are unacceptable, will be considered nonresponsive, and will be returned for resubmittal without review.

- G. Architect will discard submittals received from sources other than Contractor.

END OF SECTION 01330

SECTION 013516 - ALTERATION PROJECT PROCEDURES

PART 1 - GENERAL

1.1 RELATED DOCUMENTS

- A. Drawings and general provisions of the Contract, including General and Supplementary Conditions and Division 01 Specification Sections, apply to this Section.

1.2 SUMMARY

- A. Section includes special procedures for alteration work.

1.3 DEFINITIONS

- A. Alteration Work: This term includes remodeling, renovation, repair, and maintenance work performed within existing spaces or on existing surfaces as part of the Project.
- B. Consolidate: To strengthen loose or deteriorated materials in place.
- C. Design Reference Sample: A sample that represents the Architect's prebid selection of work to be matched; it may be existing work or work specially produced for the Project.
- D. Dismantle: To remove by disassembling or detaching an item from a surface, using gentle methods and equipment to prevent damage to the item and surfaces; disposing of items unless indicated to be salvaged or reinstalled.
- E. Match: To blend with adjacent construction and manifest no apparent difference in material type, species, cut, form, detail, color, grain, texture, or finish; as approved by Architect.
- F. Refinish: To remove existing finishes to base material and apply new finish to match original, or as otherwise indicated.
- G. Repair: To correct damage and defects, retaining existing materials, features, and finishes. This includes patching, piecing-in, splicing, consolidating, or otherwise reinforcing or upgrading materials.
- H. Replace: To remove, duplicate, and reinstall entire item with new material. The original item is the pattern for creating duplicates unless otherwise indicated.
- I. Replicate: To reproduce in exact detail, materials, and finish unless otherwise indicated.
- J. Reproduce: To fabricate a new item, accurate in detail to the original, and from either the same or a similar material as the original, unless otherwise indicated.

- K. Retain: To keep existing items that are not to be removed or dismantled.
- L. Strip: To remove existing finish down to base material unless otherwise indicated.

1.4 COORDINATION

- A. Alteration Work Subschedule: A construction schedule coordinating the sequencing and scheduling of alteration work for entire Project, including each activity to be performed, and based on Contractor's Construction Schedule. Secure time commitments for performing critical construction activities from separate entities responsible for alteration work.
 - 1. Schedule construction operations in sequence required to obtain best Work results.
 - 2. Coordinate sequence of alteration work activities to accommodate the following:
 - a. Owner's continuing occupancy of portions of existing building.
 - b. Owner's partial occupancy of completed Work.
 - c. Other known work in progress.
 - d. Tests and inspections.
 - 3. Detail sequence of alteration work, with start and end dates.
 - 4. Utility Services: Indicate how long utility services will be interrupted. Coordinate shutoff, capping, and continuation of utility services.
 - 5. Use of elevator and stairs.
 - 6. Equipment Data: List gross loaded weight, axle-load distribution, and wheel-base dimension data for mobile and heavy equipment proposed for use in existing structure. Do not use such equipment without certification from Contractor's professional engineer that the structure can support the imposed loadings without damage.
- B. Pedestrian and Vehicular Circulation: Coordinate alteration work with circulation patterns within Project building(s) and site. Some work is near circulation patterns and adjacent to restricted areas. Circulation patterns cannot be closed off entirely and in places can be only temporarily redirected around small areas of work. Access to restricted areas may not be obstructed. Plan and execute the Work accordingly.

1.5 PROJECT MEETINGS FOR ALTERATION WORK

- A. Preliminary Conference for Alteration Work: Before starting alteration work, conduct conference at Project site.
 - 1. Attendees: In addition to representatives of Owner, Architect, and Contractor, Owner's insurer, testing service representative, specialists, and chemical-cleaner manufacturer(s) shall be represented at the meeting.
 - 2. Agenda: Discuss items of significance that could affect progress of alteration work, including review of the following:

- a. Alteration Work Subschedule: Discuss and finalize; verify availability of materials, specialists' personnel, equipment, and facilities needed to make progress and avoid delays.
 - b. Fire-prevention plan.
 - c. Governing regulations.
 - d. Areas where existing construction is to remain and the required protection.
 - e. Hauling routes.
 - f. Sequence of alteration work operations.
 - g. Storage, protection, and accounting for salvaged and specially fabricated items.
 - h. Existing conditions, staging, and structural loading limitations of areas where materials are stored.
 - i. Qualifications of personnel assigned to alteration work and assigned duties.
 - j. Requirements for extent and quality of work, tolerances, and required clearances.
 - k. Embedded work such as flashings and lintels, special details, collection of waste, protection of occupants and the public, and condition of other construction that affects the Work or will affect the work.
3. Reporting: Record conference results and distribute copies to everyone in attendance and to others affected by decisions or actions resulting from conference.
- B. Coordination Meetings: Conduct coordination meetings specifically for alteration work at weekly intervals. Coordination meetings are in addition to specific meetings held for other purposes, such as progress meetings and preinstallation conferences.
1. Attendees: In addition to representatives of Owner, Architect, and Contractor, each specialist, supplier, installer, and other entity concerned with progress or involved in planning, coordination, or performance of alteration work activities shall be represented at these meetings. All participants at conference shall be familiar with Project and authorized to conclude matters relating to alteration work.
 2. Agenda: Review and correct or approve minutes of previous coordination meeting. Review other items of significance that could affect progress of alteration work. Include topics for discussion as appropriate to status of Project.
 - a. Alteration Work Subschedule: Review progress since last coordination meeting. Determine whether each schedule item is on time, ahead of schedule, or behind schedule. Determine how construction behind schedule will be expedited with retention of quality; secure commitments from parties involved to do so. Discuss whether schedule revisions are required to ensure that current and subsequent activities are completed within the Contract Time.
 - b. Schedule Updating: Revise Contractor's Alteration Work Subschedule after each coordination meeting where revisions to schedule have been made or recognized. Issue revised schedule concurrently with report of each meeting.

- c. Review present and future needs of each entity present, including review items listed in the "Preliminary Conference for Alteration Work" Paragraph in this article and the following:
 - 1) Interface requirements of alteration work with other Project Work.
 - 2) Status of submittals for alteration work.
 - 3) Access to alteration work locations.
 - 4) Effectiveness of fire-prevention plan.
 - 5) Quality and work standards of alteration work.
 - 6) Change Orders for alteration work.
3. Reporting: Record meeting results and distribute copies to everyone in attendance and to others affected by decisions or actions resulting from each meeting.

1.6 MATERIALS OWNERSHIP

- A. Historic items, relics, and similar objects including, but not limited to, cornerstones and their contents, commemorative plaques and tablets, antiques, and other items of interest or value to Owner that may be encountered or uncovered during the Work, regardless of whether they were previously documented, remain Owner's property.
 1. Carefully dismantle and salvage each item or object in a manner to prevent damage and protect it from damage, then promptly deliver it to Owner where directed at Project site.

1.7 INFORMATIONAL SUBMITTALS

- A. Alteration Work Subschedule:
 1. Submit alteration work subschedule within seven days of date established for commencement of alteration work.
- B. Preconstruction Documentation: Show preexisting conditions of adjoining construction and site improvements that are to remain, including finish surfaces, that might be misconstrued as damage caused by Contractor's alteration work operations.
- C. Alteration Work Program: Submit 30 days before work begins.
- D. Fire-Prevention Plan: Submit 30 days before work begins.

1.8 QUALITY ASSURANCE

- A. Specialist Qualifications: An experienced firm regularly engaged in specialty work similar in nature, materials, design, and extent to alteration work as specified in each Section and that has completed a minimum of five recent projects with a record of successful in-service performance that demonstrates the firm's qualifications to perform this work.

1. Field Supervisor Qualifications: Full-time supervisors experienced in specialty work similar in nature, material, design, and extent to that indicated for this Project. Supervisors shall be on-site when specialty work begins and during its progress. Supervisors shall not be changed during Project except for causes beyond the control of the specialist firm.
 - a. Construct new mockups of required work whenever a supervisor is replaced.
- B. Title X Requirement: Each firm conducting activities that disturb painted surfaces shall be a "Lead-Safe Certified Firm" according to 40 CFR 745, Subpart E, and use only workers that are trained in lead-safe work practices.
- C. Alteration Work Program: Prepare a written plan for alteration work for whole Project, including each phase or process and protection of surrounding materials during operations. Show compliance with indicated methods and procedures specified in this and other Sections. Coordinate this whole-Project alteration work program with specific requirements of programs required in other alteration work Sections.
 1. Dust and Noise Control: Include locations of proposed temporary dust- and noise-control partitions and means of egress from occupied areas coordinated with continuing on-site operations and other known work in progress.
 2. Debris Hauling: Include plans clearly marked to show debris hauling routes, turning radii, and locations and details of temporary protective barriers.
- D. Fire-Prevention Plan: Prepare a written plan for preventing fires during the Work, including placement of fire extinguishers, fire blankets, rag buckets, and other fire-control devices during each phase or process. Coordinate plan with Owner's fire-protection equipment and requirements. Include fire-watch personnel's training, duties, and authority to enforce fire safety.
- E. Safety and Health Standard: Comply with ANSI/ASSE A10.6.

1.9 STORAGE AND HANDLING OF SALVAGED MATERIALS

A. Salvaged Materials:

1. Clean loose dirt and debris from salvaged items unless more extensive cleaning is indicated.
2. Pack or crate items after cleaning; cushion against damage during handling. Label contents of containers.
3. Store items in a secure area until delivery to Owner.
4. Transport items to Owner's storage area designated by Owner.
5. Protect items from damage during transport and storage.

B. Salvaged Materials for Reinstallation:

1. Repair and clean items for reuse as indicated.
2. Pack or crate items after cleaning and repairing; cushion against damage during handling. Label contents of containers.

3. Protect items from damage during transport and storage.
 4. Reinstall items in locations indicated. Comply with installation requirements for new materials and equipment unless otherwise indicated. Provide connections, supports, and miscellaneous materials to make items functional for use indicated.
- C. Existing Materials to Remain: Protect construction indicated to remain against damage and soiling from construction work. Where permitted by Architect, items may be dismantled and taken to a suitable, protected storage location during construction work and reinstalled in their original locations after alteration and other construction work in the vicinity is complete.
- D. Storage: Catalog and store items within a weathertight enclosure where they are protected from moisture, weather, condensation, and freezing temperatures.
1. Identify each item for reinstallation with a nonpermanent mark to document its original location. Indicate original locations on plans, elevations, sections, or photographs by annotating the identifying marks.
 2. Secure stored materials to protect from theft.
 3. Control humidity so that it does not exceed 85 percent. Maintain temperatures 5 deg F or more above the dew point.
- E. Storage Space:
1. Owner will arrange for limited on-site location(s) for free storage of salvaged material. This storage space includes security for stored material.
 2. Arrange for off-site locations for storage and protection of salvaged material that cannot be stored and protected on-site.

1.10 FIELD CONDITIONS

- A. Survey of Existing Conditions: Record existing conditions that affect the Work by use of measured drawings and preconstruction videotapes.
1. Comply with requirements specified in Section 013233 "Photographic Documentation."
- B. Discrepancies: Notify Architect of discrepancies between existing conditions and Drawings before proceeding with removal and dismantling work.
- C. Owner's Removals: Before beginning alteration work, verify in correspondence with Owner that the following items have been removed:
1. Existing scanner machine.
 2. Laundry storage room shelves.
- D. Size Limitations in Existing Spaces: Materials, products, and equipment used for performing the Work and for transporting debris, materials, and products shall be of sizes that clear surfaces within existing spaces, areas, rooms, and openings, including temporary protection, by 12 inches or more.

PART 2 - PRODUCTS - (Not Used)

PART 3 - EXECUTION

3.1 PROTECTION

- A. Protect persons, motor vehicles, surrounding surfaces of building, building site, plants, and surrounding buildings from harm resulting from alteration work.
 - 1. Use only proven protection methods, appropriate to each area and surface being protected.
 - 2. Provide temporary barricades, barriers, and directional signage to exclude the public from areas where alteration work is being performed.
 - 3. Erect temporary barriers to form and maintain fire-egress routes.
 - 4. Erect temporary protective covers over walkways and at points of pedestrian and vehicular entrance and exit that must remain in service during alteration work.
 - 5. Contain dust and debris generated by alteration work, and prevent it from reaching the public or adjacent surfaces.
 - 6. Provide shoring, bracing, and supports as necessary. Do not overload structural elements.
 - 7. Protect floors and other surfaces along hauling routes from damage, wear, and staining.
 - 8. Provide supplemental sound-control treatment to isolate demolition work from other areas of the building.
- B. Temporary Protection of Materials to Remain:
 - 1. Protect existing materials with temporary protections and construction. Do not remove existing materials unless otherwise indicated.
 - 2. Do not attach temporary protection to existing surfaces except as indicated as part of the alteration work program.
- C. Comply with each product manufacturer's written instructions for protections and precautions. Protect against adverse effects of products and procedures on people and adjacent materials, components, and vegetation.
- D. Utility and Communications Services:
 - 1. Notify Owner, Architect, authorities having jurisdiction, and entities owning or controlling wires, conduits, pipes, and other services affected by alteration work before commencing operations.
 - 2. Disconnect and cap pipes and services as required by authorities having jurisdiction, as required for alteration work.
 - 3. Maintain existing services unless otherwise indicated; keep in service, and protect against damage during operations. Provide temporary services during interruptions to existing utilities.
- E. Existing Drains: Prior to the start of work in an area, test drainage system to ensure that it is functioning properly. Notify Architect immediately of inadequate drainage or

blockage. Do not begin work in an area until the drainage system is functioning properly.

1. Prevent solids such as adhesive or mortar residue or other debris from entering the drainage system. Clean out drains and drain lines that become sluggish or blocked by sand or other materials resulting from alteration work.
2. Protect drains from pollutants. Block drains or filter out sediments, allowing only clean water to pass.

3.2 PROTECTION FROM FIRE

A. General: Follow fire-prevention plan and the following:

1. Comply with NFPA 241 requirements unless otherwise indicated. Perform duties titled "Owner's Responsibility for Fire Protection."
2. Remove and keep area free of combustibles, including rubbish, paper, waste, and chemicals, unless necessary for the immediate work.
 - a. If combustible material cannot be removed, provide fire blankets to cover such materials.

B. Heat-Generating Equipment and Combustible Materials: Comply with the following procedures while performing work with heat-generating equipment or combustible materials, including welding, torch-cutting, soldering, brazing, removing paint with heat, or other operations where open flames or implements using high heat or combustible solvents and chemicals are anticipated:

1. Obtain Owner's approval for operations involving use of welding or other high-heat equipment. Use of open-flame equipment is not permitted. Notify Owner at least 72 hours before each occurrence, indicating location of such work.
2. As far as practicable, restrict heat-generating equipment to shop areas or outside the building.
3. Do not perform work with heat-generating equipment in or near rooms or in areas where flammable liquids or explosive vapors are present or thought to be present. Use a combustible gas indicator test to ensure that the area is safe.
4. Use fireproof baffles to prevent flames, sparks, hot gases, or other high-temperature material from reaching surrounding combustible material.
5. Prevent the spread of sparks and particles of hot metal through open windows, doors, holes, and cracks in floors, walls, ceilings, roofs, and other openings.
6. Fire Watch: Before working with heat-generating equipment or combustible materials, station personnel to serve as a fire watch at each location where such work is performed. Fire-watch personnel shall have the authority to enforce fire safety. Station fire watch according to NFPA 51B, NFPA 241, and as follows:
 - a. Train each fire watch in the proper operation of fire-control equipment and alarms.
 - b. Prohibit fire-watch personnel from other work that would be a distraction from fire-watch duties.
 - c. Cease work with heat-generating equipment whenever fire-watch personnel are not present.

- d. Have fire-watch personnel perform final fire-safety inspection each day beginning no sooner than 30 minutes after conclusion of work in each area to detect hidden or smoldering fires and to ensure that proper fire prevention is maintained.
 - e. Maintain fire-watch personnel at each area of Project site until 60 minutes after conclusion of daily work.
- C. Fire-Control Devices: Provide and maintain fire extinguishers, fire blankets, and rag buckets for disposal of rags with combustible liquids. Maintain each as suitable for the type of fire risk in each work area. Ensure that nearby personnel and the fire-watch personnel are trained in fire-extinguisher and blanket use.
- D. Sprinklers: Where sprinkler protection exists and is functional, maintain it without interruption while operations are being performed. If operations are performed close to sprinklers, shield them temporarily with guards.
- 1. Remove temporary guards at the end of work shifts, whenever operations are paused, and when nearby work is complete.

3.3 PROTECTION DURING APPLICATION OF CHEMICALS

- A. Protect motor vehicles, surrounding surfaces of building, building site, plants, and surrounding buildings from harm or spillage resulting from applications of chemicals and adhesives.
- B. Cover adjacent surfaces with protective materials that are proven to resist chemicals selected for Project unless chemicals being used will not damage adjacent surfaces as indicated in alteration work program. Use covering materials and masking agents that are waterproof and UV resistant and that will not stain or leave residue on surfaces to which they are applied. Apply protective materials according to manufacturer's written instructions. Do not apply liquid masking agents or adhesives to painted or porous surfaces. When no longer needed, promptly remove protective materials.
- C. Do not apply chemicals during winds of sufficient force to spread them to unprotected surfaces.
- D. Neutralize alkaline and acid wastes and legally dispose of off Owner's property.
- E. Collect and dispose of runoff from chemical operations by legal means and in a manner that prevents soil contamination, soil erosion, undermining of paving and foundations, damage to landscaping, or water penetration into building interior.

3.4 GENERAL ALTERATION WORK

- A. Have specialty work performed only by qualified specialists.
- B. Ensure that supervisory personnel are present when work begins and during its progress.

- C. Record existing work before each procedure (preconstruction), and record progress during the work. Use digital preconstruction documentation photographs or video recordings.
- D. Perform surveys of Project site as the Work progresses to detect hazards resulting from alterations.
- E. Notify Architect of visible changes in the integrity of material or components whether from environmental causes including biological attack, UV degradation, freezing, or thawing or from structural defects including cracks, movement, or distortion.
 - 1. Do not proceed with the work in question until directed by Architect.

END OF SECTION 013516

SECTION 014000 - QUALITY REQUIREMENTS

PART 1 - GENERAL

1.1 RELATED DOCUMENTS

- A. Drawings and general provisions of the Contract, including General and Supplementary Conditions and other Division 01 Specification Sections, apply to this Section.

1.2 SUMMARY

- A. Section includes administrative and procedural requirements for quality assurance and quality control.
- B. Testing and inspection services are required to verify compliance with requirements specified or indicated. These services do not relieve Contractor of responsibility for compliance with the Contract Document requirements.
 - 1. Specific quality-assurance and quality-control requirements for individual work results are specified in their respective Specification Sections. Requirements in individual Sections may also cover production of standard products.
 - 2. Specified tests, inspections, and related actions do not limit Contractor's other quality-assurance and quality-control procedures that facilitate compliance with the Contract Document requirements.
 - 3. Requirements for Contractor to provide quality-assurance and quality-control services required by Architect, Owner, or authorities having jurisdiction are not limited by provisions of this Section.
 - 4. Specific test and inspection requirements are not specified in this Section.

1.3 DEFINITIONS

- A. Experienced: When used with an entity or individual, "experienced" unless otherwise further described means having successfully completed a minimum of five previous projects similar in nature, size, and extent to this Project; being familiar with special requirements indicated; and having complied with requirements of authorities having jurisdiction.
- B. Field Quality-Control Tests: Tests and inspections that are performed on-site for installation of the Work and for completed Work.
- C. Installer/Applicator/Erector: Contractor or another entity engaged by Contractor as an employee, Subcontractor, or Sub-subcontractor, to perform a particular construction operation, including installation, erection, application, assembly, and similar operations.

1. Use of trade-specific terminology in referring to a trade or entity does not require that certain construction activities be performed by accredited or unionized individuals, or that requirements specified apply exclusively to specific trade(s).
- D. Preconstruction Testing: Tests and inspections performed specifically for Project before products and materials are incorporated into the Work, to verify performance or compliance with specified criteria.
- E. Product Tests: Tests and inspections that are performed by a nationally recognized testing laboratory (NRTL) according to 29 CFR 1910.7, by a testing agency accredited according to NIST's National Voluntary Laboratory Accreditation Program (NVLAP), or by a testing agency qualified to conduct product testing and acceptable to authorities having jurisdiction, to establish product performance and compliance with specified requirements.
- F. Source Quality-Control Tests: Tests and inspections that are performed at the source; for example, plant, mill, factory, or shop.
- G. Testing Agency: An entity engaged to perform specific tests, inspections, or both. Testing laboratory shall mean the same as testing agency.
- H. Quality-Assurance Services: Activities, actions, and procedures performed before and during execution of the Work to guard against defects and deficiencies and substantiate that proposed construction will comply with requirements.
- I. Quality-Control Services: Tests, inspections, procedures, and related actions during and after execution of the Work to evaluate that actual products incorporated into the Work and completed construction comply with requirements. Contractor's quality-control services do not include contract administration activities performed by Architect.

1.4 DELEGATED-DESIGN SERVICES

- A. Performance and Design Criteria: Where professional design services or certifications by a design professional are specifically required of Contractor by the Contract Documents, provide products and systems complying with specific performance and design criteria indicated.
 1. If criteria indicated are not sufficient to perform services or certification required, submit a written request for additional information to Architect.

1.5 CONFLICTING REQUIREMENTS

- A. Conflicting Standards and Other Requirements: If compliance with two or more standards or requirements are specified and the standards or requirements establish different or conflicting requirements for minimum quantities or quality levels, comply with the most stringent requirement. Refer conflicting requirements that are different, but apparently equal, to Architect for direction before proceeding.

- B. Minimum Quantity or Quality Levels: The quantity or quality level shown or specified shall be the minimum provided or performed. The actual installation may comply exactly with the minimum quantity or quality specified, or it may exceed the minimum within reasonable limits. To comply with these requirements, indicated numeric values are minimum or maximum, as appropriate, for the context of requirements. Refer uncertainties to Architect for a decision before proceeding.

1.6 ACTION SUBMITTALS

- A. Delegated-Design Services Submittal: In addition to Shop Drawings, Product Data, and other required submittals, submit a statement signed and sealed by the responsible design professional, for each product and system specifically assigned to Contractor to be designed or certified by a design professional, indicating that the products and systems are in compliance with performance and design criteria indicated. Include list of codes, loads, and other factors used in performing these services.

1.7 INFORMATIONAL SUBMITTALS

- A. Contractor's Quality-Control Plan: For quality-assurance and quality-control activities and responsibilities.
- B. Qualification Data: For Contractor's quality-control personnel.
- C. Contractor's Statement of Responsibility: When required by authorities having jurisdiction, submit copy of written statement of responsibility submitted to authorities having jurisdiction before starting work on the following systems:
 - 1. Seismic-force-resisting system, designated seismic system, or component listed in the Statement of Special Inspections.
 - 2. Main wind-force-resisting system or a wind-resisting component listed in the Statement of Special Inspections.
- D. Testing Agency Qualifications: For testing agencies specified in "Quality Assurance" Article to demonstrate their capabilities and experience. Include proof of qualifications in the form of a recent report on the inspection of the testing agency by a recognized authority.
- E. Schedule of Tests and Inspections: Prepare in tabular form and include the following:
 - 1. Specification Section number and title.
 - 2. Entity responsible for performing tests and inspections.
 - 3. Description of test and inspection.
 - 4. Identification of applicable standards.
 - 5. Identification of test and inspection methods.
 - 6. Number of tests and inspections required.
 - 7. Time schedule or time span for tests and inspections.
 - 8. Requirements for obtaining samples.
 - 9. Unique characteristics of each quality-control service.

- F. Reports: Prepare and submit certified written reports and documents as specified.
- G. Permits, Licenses, and Certificates: For Owner's record, submit copies of permits, licenses, certifications, inspection reports, releases, jurisdictional settlements, notices, receipts for fee payments, judgments, correspondence, records, and similar documents established for compliance with standards and regulations bearing on performance of the Work.

1.8 CONTRACTOR'S QUALITY-CONTROL PLAN

- A. Quality-Control Plan, General: Submit quality-control plan within 10 days of Notice of Award, and not less than five days prior to preconstruction conference. Submit in format acceptable to Architect. Identify personnel, procedures, controls, instructions, tests, records, and forms to be used to carry out Contractor's quality-assurance and quality-control responsibilities. Coordinate with Contractor's Construction Schedule.
- B. Quality-Control Personnel Qualifications: Engage qualified personnel trained and experienced in managing and executing quality-assurance and quality-control procedures similar in nature and extent to those required for Project.
 - 1. Project quality-control manager may also serve as Project superintendent.
- C. Submittal Procedure: Describe procedures for ensuring compliance with requirements through review and management of submittal process. Indicate qualifications of personnel responsible for submittal review.
- D. Testing and Inspection: In quality-control plan, include a comprehensive schedule of Work requiring testing or inspection, including the following:
 - 1. Contractor-performed tests and inspections including Subcontractor-performed tests and inspections. Include required tests and inspections and Contractor-elected tests and inspections. Distinguish source quality-control tests and inspections from field quality-control tests and inspections.
 - 2. Special inspections required by authorities having jurisdiction and indicated on the Statement of Special Inspections.
 - 3. Owner-performed tests and inspections indicated in the Contract Documents.
- E. Continuous Inspection of Workmanship: Describe process for continuous inspection during construction to identify and correct deficiencies in workmanship in addition to testing and inspection specified. Indicate types of corrective actions to be required to bring work into compliance with standards of workmanship established by Contract requirements and approved mockups.
- F. Monitoring and Documentation: Maintain testing and inspection reports including log of approved and rejected results. Include work Architect has indicated as nonconforming or defective. Indicate corrective actions taken to bring nonconforming work into compliance with requirements. Comply with requirements of authorities having jurisdiction.

1.9 REPORTS AND DOCUMENTS

- A. Test and Inspection Reports: Prepare and submit certified written reports specified in other Sections. Include the following:
1. Date of issue.
 2. Project title and number.
 3. Name, address, telephone number, and email address of testing agency.
 4. Dates and locations of samples and tests or inspections.
 5. Names of individuals making tests and inspections.
 6. Description of the Work and test and inspection method.
 7. Identification of product and Specification Section.
 8. Complete test or inspection data.
 9. Test and inspection results and an interpretation of test results.
 10. Record of temperature and weather conditions at time of sample taking and testing and inspection.
 11. Comments or professional opinion on whether tested or inspected Work complies with the Contract Document requirements.
 12. Name and signature of laboratory inspector.
 13. Recommendations on retesting and reinspecting.
- B. Manufacturer's Technical Representative's Field Reports: Prepare written information documenting manufacturer's technical representative's tests and inspections specified in other Sections. Include the following:
1. Name, address, telephone number, and email address of technical representative making report.
 2. Statement on condition of substrates and their acceptability for installation of product.
 3. Statement that products at Project site comply with requirements.
 4. Summary of installation procedures being followed, whether they comply with requirements and, if not, what corrective action was taken.
 5. Results of operational and other tests and a statement of whether observed performance complies with requirements.
 6. Statement whether conditions, products, and installation will affect warranty.
 7. Other required items indicated in individual Specification Sections.
- C. Factory-Authorized Service Representative's Reports: Prepare written information documenting manufacturer's factory-authorized service representative's tests and inspections specified in other Sections. Include the following:
1. Name, address, telephone number, and email address of factory-authorized service representative making report.
 2. Statement that equipment complies with requirements.
 3. Results of operational and other tests and a statement of whether observed performance complies with requirements.
 4. Statement whether conditions, products, and installation will affect warranty.
 5. Other required items indicated in individual Specification Sections.

1.10 QUALITY ASSURANCE

- A. General: Qualifications paragraphs in this article establish the minimum qualification levels required; individual Specification Sections specify additional requirements.
- B. Manufacturer Qualifications: A firm experienced in manufacturing products or systems similar to those indicated for this Project and with a record of successful in-service performance, as well as sufficient production capacity to produce required units. As applicable, procure products from manufacturers able to meet qualification requirements, warranty requirements, and technical or factory-authorized service representative requirements.
- C. Fabricator Qualifications: A firm experienced in producing products similar to those indicated for this Project and with a record of successful in-service performance, as well as sufficient production capacity to produce required units.
- D. Installer Qualifications: A firm or individual experienced in installing, erecting, applying, or assembling work similar in material, design, and extent to that indicated for this Project, whose work has resulted in construction with a record of successful in-service performance.
- E. Professional Engineer Qualifications: A professional engineer who is legally qualified to practice in jurisdiction where Project is located and who is experienced in providing engineering services of the kind indicated. Engineering services are defined as those performed for installations of the system, assembly, or product that are similar in material, design, and extent to those indicated for this Project.
- F. Specialists: Certain Specification Sections require that specific construction activities shall be performed by entities who are recognized experts in those operations. Specialists shall satisfy qualification requirements indicated and shall be engaged for the activities indicated.
 - 1. Requirements of authorities having jurisdiction shall supersede requirements for specialists.
- G. Testing Agency Qualifications: An NRTL, an NVLAP, or an independent agency with the experience and capability to conduct testing and inspection indicated, as documented according to ASTM E 329; and with additional qualifications specified in individual Sections; and, where required by authorities having jurisdiction, that is acceptable to authorities.
- H. Manufacturer's Technical Representative Qualifications: An authorized representative of manufacturer who is trained and approved by manufacturer to observe and inspect installation of manufacturer's products that are similar in material, design, and extent to those indicated for this Project.
- I. Factory-Authorized Service Representative Qualifications: An authorized representative of manufacturer who is trained and approved by manufacturer to inspect installation of manufacturer's products that are similar in material, design, and extent to those indicated for this Project.

- J. Preconstruction Testing: Where testing agency is indicated to perform preconstruction testing for compliance with specified requirements for performance and test methods, comply with the following:
1. Contractor responsibilities include the following:
 - a. Provide test specimens representative of proposed products and construction.
 - b. Submit specimens in a timely manner with sufficient time for testing and analyzing results to prevent delaying the Work.
 - c. When testing is complete, remove test specimens and test assemblies, and mockups; do not reuse products on Project.
 2. Testing Agency Responsibilities: Submit a certified written report of each test, inspection, and similar quality-assurance service to Architect, with copy to Contractor. Interpret tests and inspections and state in each report whether tested and inspected work complies with or deviates from the Contract Documents.

1.11 QUALITY CONTROL

- A. Owner Responsibilities: Where quality-control services are indicated as Owner's responsibility, Owner will engage a qualified testing agency to perform these services.
1. Owner will furnish Contractor with names, addresses, and telephone numbers of testing agencies engaged and a description of types of testing and inspection they are engaged to perform.
 2. Payment for these services will be made from testing and inspection allowances, as authorized by Change Orders.
 3. Costs for retesting and reinspecting construction that replaces or is necessitated by work that failed to comply with the Contract Documents will be charged to Contractor, and the Contract Sum will be adjusted by Change Order.
- B. Contractor Responsibilities: Tests and inspections not explicitly assigned to Owner are Contractor's responsibility. Perform additional quality-control activities, whether specified or not, to verify and document that the Work complies with requirements.
1. Unless otherwise indicated, provide quality-control services specified and those required by authorities having jurisdiction. Perform quality-control services required of Contractor by authorities having jurisdiction, whether specified or not.
 2. Engage a qualified testing agency to perform quality-control services.
 - a. Contractor shall not employ same entity engaged by Owner, unless agreed to in writing by Owner.
 3. Notify testing agencies at least 24 hours in advance of time when Work that requires testing or inspection will be performed.
 4. Where quality-control services are indicated as Contractor's responsibility, submit a certified written report, in duplicate, of each quality-control service.

5. Testing and inspection requested by Contractor and not required by the Contract Documents are Contractor's responsibility.
 6. Submit additional copies of each written report directly to authorities having jurisdiction, when they so direct.
- C. Retesting/Reinspecting: Regardless of whether original tests or inspections were Contractor's responsibility, provide quality-control services, including retesting and reinspecting, for construction that replaced Work that failed to comply with the Contract Documents.
- D. Testing Agency Responsibilities: Cooperate with Architect and Contractor in performance of duties. Provide qualified personnel to perform required tests and inspections.
1. Notify Architect and Contractor promptly of irregularities or deficiencies observed in the Work during performance of its services.
 2. Determine the locations from which test samples will be taken and in which in-situ tests are conducted.
 3. Conduct and interpret tests and inspections and state in each report whether tested and inspected work complies with or deviates from requirements.
 4. Submit a certified written report, in duplicate, of each test, inspection, and similar quality-control service through Contractor.
 5. Do not release, revoke, alter, or increase the Contract Document requirements or approve or accept any portion of the Work.
 6. Do not perform duties of Contractor.
- E. Manufacturer's Field Services: Where indicated, engage a factory-authorized service representative to inspect field-assembled components and equipment installation, including service connections. Report results in writing as specified in Section 013300 "Submittal Procedures."
- F. Manufacturer's Technical Services: Where indicated, engage a manufacturer's technical representative to observe and inspect the Work. Manufacturer's technical representative's services include participation in preinstallation conferences, examination of substrates and conditions, verification of materials, observation of Installer activities, inspection of completed portions of the Work, and submittal of written reports.
- G. Associated Contractor Services: Cooperate with agencies and representatives performing required tests, inspections, and similar quality-control services, and provide reasonable auxiliary services as requested. Notify agency sufficiently in advance of operations to permit assignment of personnel. Provide the following:
1. Access to the Work.
 2. Incidental labor and facilities necessary to facilitate tests and inspections.
 3. Adequate quantities of representative samples of materials that require testing and inspection. Assist agency in obtaining samples.
 4. Facilities for storage and field curing of test samples.
 5. Delivery of samples to testing agencies.
 6. Preliminary design mix proposed for use for material mixes that require control by testing agency.

7. Security and protection for samples and for testing and inspection equipment at Project site.

- H. Coordination: Coordinate sequence of activities to accommodate required quality-assurance and quality-control services with a minimum of delay and to avoid necessity of removing and replacing construction to accommodate testing and inspection.
 1. Schedule times for tests, inspections, obtaining samples, and similar activities.

- I. Schedule of Tests and Inspections: Prepare a schedule of tests, inspections, and similar quality-control services required by the Contract Documents as a component of Contractor's quality-control plan. Coordinate and submit concurrently with Contractor's Construction Schedule. Update as the Work progresses.
 1. Distribution: Distribute schedule to Owner, Architect, testing agencies, and each party involved in performance of portions of the Work where tests and inspections are required.

1.12 SPECIAL TESTS AND INSPECTIONS

- A. Special Tests and Inspections: Engage a qualified testing agency and/or special inspector to conduct special tests and inspections required by authorities having jurisdiction as the responsibility of Owner, and as follows:
 1. Verifying that manufacturer maintains detailed fabrication and quality-control procedures and reviewing the completeness and adequacy of those procedures to perform the Work.
 2. Notifying Architect and Contractor promptly of irregularities and deficiencies observed in the Work during performance of its services.
 3. Submitting a certified written report of each test, inspection, and similar quality-control service to Architect with copy to Contractor and to authorities having jurisdiction.
 4. Submitting a final report of special tests and inspections at Substantial Completion, which includes a list of unresolved deficiencies.
 5. Interpreting tests and inspections and stating in each report whether tested and inspected work complies with or deviates from the Contract Documents.
 6. Retesting and reinspecting corrected work.

- B. Special Tests and Inspections: Conducted by a qualified testing agency or special inspector as required by authorities having jurisdiction, as indicated in individual Specification Sections, and as follows:
 1. Verifying that manufacturer maintains detailed fabrication and quality-control procedures and reviewing the completeness and adequacy of those procedures to perform the Work.
 2. Notifying Architect and Contractor promptly of irregularities and deficiencies observed in the Work during performance of its services.
 3. Submitting a certified written report of each test, inspection, and similar quality-control service to Architect with copy to Contractor and to authorities having jurisdiction.

4. Submitting a final report of special tests and inspections at Substantial Completion, which includes a list of unresolved deficiencies.
5. Interpreting tests and inspections and stating in each report whether tested and inspected work complies with or deviates from the Contract Documents.
6. Retesting and reinspecting corrected work.

PART 2 - PRODUCTS (Not Used)

PART 3 - EXECUTION

3.1 TEST AND INSPECTION LOG

- A. Test and Inspection Log: Prepare a record of tests and inspections. Include the following:
 1. Date test or inspection was conducted.
 2. Description of the Work tested or inspected.
 3. Date test or inspection results were transmitted to Architect.
 4. Identification of testing agency or special inspector conducting test or inspection.
- B. Maintain log at Project site. Post changes and revisions as they occur. Provide access to test and inspection log for Architect's reference during normal working hours.
 1. Submit log at Project closeout as part of Project Record Documents.

3.2 REPAIR AND PROTECTION

- A. General: On completion of testing, inspection, sample taking, and similar services, repair damaged construction and restore substrates and finishes.
 1. Provide materials and comply with installation requirements specified in other Specification Sections or matching existing substrates and finishes. Restore patched areas and extend restoration into adjoining areas with durable seams that are as invisible as possible. Comply with the Contract Document requirements for cutting and patching in Section 017300 "Execution."
- B. Protect construction exposed by or for quality-control service activities.
- C. Repair and protection are Contractor's responsibility, regardless of the assignment of responsibility for quality-control services.

END OF SECTION 014000

SECTION 015000 - TEMPORARY FACILITIES AND CONTROLS

PART 1 - GENERAL

1.1 SUMMARY

- A. This Section includes requirements for temporary security partitions at entry into housing modules, temporary utilities, support facilities, security and protection facilities.
- B. See Division 1 Section "Execution" for progress cleaning requirements.

1.2 USE CHARGES

- A. **General:** Cost or use charges for temporary facilities shall be included in the Contract Sum. Allow other entities to use temporary services and facilities without cost, including, but not limited to, Owner's Construction Manager, Architect, testing agencies, and authorities having jurisdiction.
- B. **Water Service:** Water from Owner's existing water system is available for use without metering and without payment of use charges. Provide connections and extensions of services as required for construction operations.
- C. **Electric Power Service:** Electric power from Owner's existing system is available for use without metering and without payment of use charges. Provide connections and extensions of services as required for construction operations.

1.3 SUBMITTALS

- A. **Site Plan:** Show temporary facilities, utility hookups, staging areas, and parking areas for construction personnel.

1.4 QUALITY ASSURANCE

- A. **Electric Service:** Comply with NECA, NEMA, and UL standards and regulations for temporary electric service. Install service to comply with NFPA 70.
- B. **Tests and Inspections:** Arrange for authorities having jurisdiction to test and inspect each temporary utility before use. Obtain required certifications and permits.

1.5 PROJECT CONDITIONS

- A. **Temporary Use of Permanent Facilities:** Installer of each permanent service shall assume responsibility for operation, maintenance, and protection of each permanent service during its use as a construction facility before Owner's acceptance, regardless of previously assigned responsibilities.

PART 2 - PRODUCTS

2.1 MATERIALS

- A. Chain-Link Fencing: Minimum 2-inch (50-mm), 0.148-inch- (3.8-mm-) thick, galvanized-steel, chain-link fabric fencing; minimum 6 feet (1.8 m) high with galvanized-steel pipe posts; minimum 2-3/8-inch- (60-mm-) OD line posts and 2-7/8-inch- (73-mm-) OD corner and pull posts, with galvanized barbed-wire top strand.
- B. Polyethylene Sheet: Reinforced, fire-resistive sheet, 10-mil (0.25-mm) minimum thickness, with flame-spread rating of 15 or less per ASTM E 84 and passing NFPA 701 Test Method 2.
- C. Dust-Control Adhesive-Surface Walk-Off Mats: Provide mats minimum 36 by 60 inches (914 by 1524 mm).
- D. Insulation: Unfaced mineral-fiber blanket, manufactured from glass, slag wool, or rock wool; with maximum flame-spread and smoke-developed indexes of 25 and 50, respectively.

2.2 TEMPORARY FACILITIES

- A. Field Offices, General: Not allowed on the DC Jail site.
- B. Storage and Fabrication Sheds: Provide sheds sized, furnished, and equipped to accommodate materials and equipment for construction operations.

2.3 EQUIPMENT

- A. Fire Extinguishers: Portable, UL rated; with class and extinguishing agent as required by locations and classes of fire exposures.

PART 3 - EXECUTION

3.1 INSTALLATION, GENERAL

- A. Locate facilities where they will serve Project adequately and result in minimum interference with performance of the Work. Relocate and modify facilities as required by progress of the Work.
 - 1. Locate facilities to limit site disturbance as specified in Division 1 Section "Summary of Work."
- B. Provide each facility ready for use when needed to avoid delay. Do not remove until facilities are no longer needed or are replaced by authorized use of completed permanent facilities.

3.2 TEMPORARY UTILITY INSTALLATION

- A. General: Install temporary service or connect to existing service.
 - 1. Arrange with utility company, Owner, and existing users for time when service can be interrupted, if necessary, to make connections for temporary services.
- B. Sewers and Drainage: Provide temporary utilities to remove effluent lawfully.
 - 1. Connect temporary sewers to municipal system as directed by authorities having jurisdiction.
- C. Water Service: Use of Owner's existing water service facilities will be permitted, as long as facilities are cleaned and maintained in a condition acceptable to Owner. At Substantial Completion, restore these facilities to condition existing before initial use.
- D. Sanitary Facilities: Provide temporary toilets, wash facilities, and drinking water for use of construction personnel. Comply with authorities having jurisdiction for type, number, location, operation, and maintenance of fixtures and facilities.
 - 1. Toilets: Use of Owner's existing toilet facilities will be permitted, as long as facilities are cleaned and maintained in a condition acceptable to Owner. At Substantial Completion, restore these facilities to condition existing before initial use.
- E. Temporary Heating and Cooling: Provide temporary heating and cooling required by construction activities for curing or drying of completed installations or for protecting installed construction from adverse effects of low temperatures or high humidity. Select equipment that will not have a harmful effect on completed installations or elements being installed.
 - 1. Provide temporary dehumidification systems when required to reduce ambient and substrate moisture levels to level required to allow installation or application of finishes and their proper curing or drying.
- F. Isolation of Work Areas in Occupied Facilities: Prevent dust, fumes, and odors from entering occupied areas.
 - 1. Prior to commencing work, isolate the HVAC system in area where work is to be performed according to coordination drawings.
 - a. Disconnect supply and return ductwork in work area from HVAC systems servicing occupied areas.
 - b. Maintain negative air pressure within work area using HEPA-equipped air-filtration units, starting with commencement of temporary partition construction, and continuing until removal of temporary partitions is complete.
 - 2. Maintain dust partitions during the Work. Use vacuum collection attachments on dust-producing equipment. Isolate limited work within occupied areas using portable dust-containment devices.

3. Perform daily construction cleanup and final cleanup using approved, HEPA-filter-equipped vacuum equipment.
- G. Electric Power Service: Use of Owner's existing electric power service will be permitted, as long as equipment is maintained in a condition acceptable to Owner.
- H. Telephone Service: Provide temporary telephone service in common-use facilities for use by all construction personnel. Install one telephone line for each field office.
1. Provide additional telephone lines for the following:
 - a. Provide a dedicated telephone line for each facsimile machine and computer in each field office.
 2. At each telephone, post a list of important telephone numbers including police and fire departments, Contractor's home office, Architect's office, Owner's office, Principal subcontractors' field and home offices.
 3. Provide superintendent with cellular telephone or portable two-way radio for use when away from field office.
- I. Electronic Communication Service: Provide temporary electronic communication service, including electronic mail in field office.

3.3 SUPPORT FACILITIES INSTALLATION

- A. General: Comply with the following:
1. Provide incombustible construction for offices, shops, and sheds located within construction area or within 30 feet of building lines. Comply with NFPA 241.
 2. Maintain support facilities until near Substantial Completion. Remove before Substantial Completion. Personnel remaining after Substantial Completion will be permitted to use permanent facilities, under conditions acceptable to Owner.
- B. Parking: Use designated parking areas for the public or as directed by DOC.
- C. Waste Disposal Facilities: Provide waste-collection containers in sizes adequate to handle waste from construction operations. Comply with requirements of authorities having jurisdiction. Comply with Division 1 Section "Execution" for progress cleaning requirements.
- D. Lifts and Hoists: Provide facilities necessary for hoisting materials and personnel.
1. Truck cranes and similar devices used for hoisting materials are considered "tools and equipment" and not temporary facilities.
- E. Existing Elevator Use: Use of Owner's existing elevators will not be permitted, unless coordinated with the Owner for specific purposes only.
- F. Existing Stair Usage: Use of Owner's existing stairs will be permitted for workers to access work areas, as long as stairs are cleaned and maintained in a condition

acceptable to Owner. Security screening and access must be coordinated with the Owner's Representative.

1. Provide protective coverings, barriers, devices, signs, or other procedures to protect stairs and to maintain means of egress. If, despite such protection, stairs become damaged, restore damaged areas so no evidence remains of correction work.

3.4 SECURITY AND PROTECTION FACILITIES INSTALLATION

- A. Environmental Protection: Provide protection, operate temporary facilities, and conduct construction in ways and by methods that comply with environmental regulations and that minimize possible air, contamination or pollution or other undesirable effects.
- B. Security Enclosure and Lockup: Install substantial temporary enclosure around partially completed areas of construction. Provide lockable entrances to prevent unauthorized entrance, vandalism, theft, and similar violations of security.
- C. Barricades, Warning Signs, and Lights: Comply with requirements of authorities having jurisdiction for erecting structurally adequate barricades, including warning signs and lighting.
- D. Temporary Enclosures: Provide temporary enclosures for protection of construction, in progress and completed, from exposure, foul weather, other construction operations, and similar activities. Provide temporary weathertight enclosure for building exterior.
- E. Temporary Security Partitions: During the construction in each housing module, provide floor-to-ceiling dustproof security partitions to limit dust and dirt migration and to separate areas occupied by Owner from phased construction activities, fumes and noise. Temporary security partition is intended to separate the area of work from the adjacent occupied housing modules. Upon completion of work in a phase, remove temporary security partition and relocate to the next phase of work. Use approved partition type for phased separation within the building.
 1. Construct dustproof partitions with 1 layer of $\frac{3}{4}$ " plywood (secure side) over 6-mil polyethylene sheet and expanded metal lath on 2x4 studs at 24" O.C. Anchor to floor and ceiling/structure.
 2. Seal joints and perimeter. Equip partitions with dustproof doors and security locks.
 3. Protect air-handling equipment.
 4. Weather strip openings.
- F. Temporary Fire Protection: Install and maintain temporary fire-protection facilities of types needed to protect against reasonably predictable and controllable fire losses. Comply with NFPA 241.
 1. Prohibit smoking in building.
 2. Supervise welding operations and similar sources of fire ignition according to requirements of authorities having jurisdiction.

3. Develop and supervise an overall fire-prevention and -protection program for personnel at Project site. Review needs with local fire department and establish procedures to be followed. Instruct personnel in methods and procedures. Post warnings and information.

3.5 OPERATION, TERMINATION, AND REMOVAL

- A. Supervision: Enforce strict discipline in use of temporary facilities. To minimize waste and abuse, limit availability of temporary facilities to essential and intended uses.
- B. Maintenance: Maintain facilities in good operating condition until removal.
 1. Maintain operation of temporary enclosures, heating, cooling, humidity control, ventilation, and similar facilities on a 24-hour basis where required to achieve indicated results and to avoid possibility of damage.
- C. Temporary Facility Changeover: Do not change over from using temporary security and protection facilities to permanent facilities until Substantial Completion. Refer to phasing plans for sequencing.
- D. Termination and Removal: Remove each temporary facility when need for its service has ended, when it has been replaced by authorized use of a permanent facility, or no later than Substantial Completion. Complete or, if necessary, restore permanent construction that may have been delayed because of interference with temporary facility. Repair damaged Work, clean exposed surfaces, and replace construction that cannot be satisfactorily repaired.
 1. Materials and facilities that constitute temporary facilities are property of Contractor. Owner reserves right to take possession of Project identification signs.
 2. At Substantial Completion, clean and renovate permanent facilities used during construction period. Comply with final cleaning requirements specified in Division 1 Section "Closeout Procedures."

END OF SECTION 015000

SECTION 016000 - PRODUCT REQUIREMENTS

PART 1 - GENERAL

1.1 RELATED DOCUMENTS

- A. Drawings and general provisions of the Contract, including General and Supplementary Conditions and other Division 01 Specification Sections, apply to this Section.

1.2 SUMMARY

- A. This Section includes administrative and procedural requirements for selection of products for use in Project; product delivery, storage, and handling; manufacturers' standard warranties on products; special warranties; product substitutions; and comparable products.
- B. Related Sections include the following:
 - 1. Division 01 Section "Closeout Procedures" for submitting warranties for Contract closeout.
 - 2. Divisions 02 through 33 Sections for specific requirements for warranties on products and installations specified to be warranted.

1.3 DEFINITIONS

- A. Products: Items purchased for incorporating into the Work, whether purchased for Project or taken from previously purchased stock. The term "product" includes the terms "material," "equipment," "system," and terms of similar intent.
 - 1. Named Products: Items identified by manufacturer's product name, including make or model number or other designation shown or listed in manufacturer's published product literature, that is current as of date of the Contract Documents.
 - 2. New Products: Items that have not previously been incorporated into another project or facility, Products salvaged or recycled from other projects are not considered new products.
 - 3. Comparable Product: Product that, in Architect's sole judgment, is demonstrated and approved by addendum, or where accepted as a product substitution, to have indicated qualities related to type, function, dimension, in-service performance, physical properties, appearance, and other characteristics that equal or exceed those of specified product.
- B. Basis-of-Design Product Specification: Where a specific manufacturer's product is named and accompanied by the words "basis of design," including make or model number or other designation, to establish the significant qualities related to type, function, dimension, in-service performance, physical properties, appearance, and

other characteristics for purposes of evaluating comparable products of other named manufacturers.

1.4 SUBMITTALS

- A. Product List: Submit a list, in tabular form, showing specified products. Include generic names of products required. Include manufacturer's name and proprietary product names for each product.
1. Coordinate product list with Contractor's Construction Schedule and the Submittals Schedule.
 2. Form: Tabulate information for each product under the following column headings:
 - a. Specification Section number and title.
 - b. Generic name used in the Contract Documents.
 - c. Proprietary name, model number, and similar designations.
 - d. Manufacturer's name and address.
 - e. Supplier's name and address.
 - f. Installer's name and address.
 - g. Projected delivery date or time span of delivery period.
 - h. Identification of items that require early submittal approval for scheduled delivery date.
 3. Initial Submittal: Within 15 days after Notice to Proceed, submit 3 copies of initial product list to Architect through Construction Manager. Include written explanation for omissions of data and for variations from Contract requirements.
 - a. At Contractor's option, initial submittal may be limited to product selections and designations that must be established early in Contract period.
 - b. Construction Manager and Architect will respond in writing within 15 days of receipt of initial product list. No response within this period shall not be regarded as approval for substitutions not specifically accepted by Architect. Architect's response will include list of unacceptable product selections, containing brief explanation of reasons for rejection.
 4. Within 30 days after Notice to Proceed, submit 3 copies of completed product list. Include written explanation for omissions of data and for variations from Contract requirements.
 5. Construction Manager and Architect will respond in writing within 15 days of receipt of completed product list. Construction Manager's and Architect's response, or lack of response, does not constitute waiver of requirement to comply with Contract Documents.
- B. Substitution Requests: Submit three copies of each request for consideration. Identify product or fabrication or installation method to be replaced. Include Specification Section number and title and Drawing numbers and titles.
1. Substitution Request Form: Use CSI Form 13.1A.

2. Documentation: Show compliance with requirements for substitutions and the following, as applicable:
 - a. Statement indicating why specified material or product cannot be provided.
 - b. Coordination information, including a list of changes or modifications needed to other parts of the Work and to construction performed by Owner and separate contractors, that will be necessary to accommodate proposed substitution.
 - c. Detailed comparison of significant qualities of proposed substitution with those of the Work specified. Significant qualities may include attributes such as performance, weight, size, durability, visual effect, and specific features and requirements indicated.
 - d. Product Data, including drawings and descriptions of products and fabrication and installation procedures.
 - e. Samples, where applicable or requested.
 - f. List of similar installations for completed projects with project names and addresses and names and addresses of architects and owners.
 - g. Material test reports from a qualified testing agency indicating and interpreting test results for compliance with requirements indicated.
 - h. Research/evaluation reports evidencing compliance with building code in effect for Project, from a model code organization acceptable to authorities having jurisdiction.
 - i. Detailed comparison of Contractor's Construction Schedule using proposed substitution with products specified for the Work, including effect on the overall Contract Time. If specified product or method of construction cannot be provided within the Contract Time, include letter from manufacturer, on manufacturer's letterhead, stating lack of availability or delays in delivery.
 - j. Cost information, including a proposal of change, if any, in the Contract Sum.
 - k. Contractor's certification that proposed substitution complies with requirements in the Contract Documents and is appropriate for applications indicated.
 - l. Contractor's waiver of rights to additional payment or time that may subsequently become necessary because of failure of proposed substitution to produce indicated results.
3. Substitutions will not be considered when:
 - a. Indicated on shop drawings or product data without separate formal request.
 - b. Requested directly by subcontractor of supplier.
 - c. Acceptance will require substantial revision of Contract Documents.
 - d. Proposed changes are not in keeping with general intent of Contract Documents.
4. By making requests for substitutions, Contractor:
 - a. Represents that Contractor has personally investigated proposed substitute product and determined that it is equal to or superior in all respects to that specified.

-
- b. Represents that Contractor will provide same warranty for substitution that Contractor would for that specified.
 - c. Will coordinate installation of accepted substitute, making such changes as may be required for Work to be compatible with substrates and adjacent materials, and complete in all respects.
 - d. Waives claims for additional time related to substitution which may later become apparent.
 - e. Certifies that cost data presented is complete and includes related costs under this Contract, including redesign costs, and waives claims for additional costs related to substitution which may later become apparent.
 5. Modification of Documents: Where substitution requires, for proper installation, changes to design of Work as indicated on accepted Shop Drawings, furnish drawings and specifications prepared by and bearing seal of licensed architect and engineers as appropriate, revising Contract Documents.
 - a. Submit revised Documents for acceptance in accordance with Division 01 Section "Submittal Procedures."
 - b. Revised Drawings: Sufficiently complete for proper installation of substitution and related Work.
 - 1) Include details of connection to and relationship with adjacent materials.
 - c. If, in Architect's sole judgment, proposed substitution is of such significance or deals with product or system affecting basic design or aesthetics, pay Architect for changes required to Contract Documents as follows:
 - 1) Reimburse Owner for Construction Manager's and Architect's account for time spent in changing Contract Documents at rate of 2.9 times rate of Direct Personnel Expense (DPE). Direct Personnel Expense is defined as direct salaries of Construction Manager's and Architect's personnel engaged on Project and portion of costs of mandatory, and customary contributions and benefits related thereto, including employment taxes and other statutory employee benefits, insurance, sick leave, holidays, vacations, pensions, and similar contributions and benefits.
 - d. Contractor: Responsible for cost of revised Documents, obtaining and paying for review and plan check by authorities having jurisdiction, and cost of revised construction.
 - e. Revised Drawings: Submit with Record Documents in accordance with Division 1 Section "Project Record Documents."
 6. Architect's Action: If necessary, Architect will request additional information or documentation for evaluation within 7 days of receipt of a request for substitution. Architect will notify Contractor through Construction Manager of acceptance or rejection of proposed substitution within 15 days of receipt of request, or 7 days of receipt of additional information or documentation, whichever is later.
 - a. Architect or Construction Manager will not make exhaustive attempt to determine products proposed for substitution are equivalent to, or can be

modified in order to be equivalent to specified products. Where extensive investigation is required by Construction Manager or Architect, Contractor shall reimburse Owner as follows:

- 1) Reimburse Owner for Construction Manager's and Architect's account for time spent in investigating proposed substitution at rate of 2.9 times rate of Direct Personnel Expense (DPE). Direct Personnel Expense is defined as direct salaries of Construction Manager's and Architect's personnel engaged on Project and portion of costs of mandatory, and customary contributions and benefits related thereto, including employment taxes and other statutory employee benefits, insurance, sick leave, holidays, vacations, pensions, and similar contributions and benefits.
 - b. Form of Acceptance: Change Order.
 - c. Use product specified if Architect cannot make a decision on use of a proposed substitution within time allocated.
- C. Comparable Product Requests: Submit three copies of each request for consideration. Identify product or fabrication or installation method to be replaced. Include Specification Section number and title and Drawing numbers and titles.
 1. Architect's Action: If necessary, Architect will request additional information or documentation for evaluation within one week of receipt of a comparable product request. Architect will notify Contractor through Construction Manager of approval or rejection of proposed comparable product request within 15 days of receipt of request, or 7 days of receipt of additional information or documentation, whichever is later.
 - a. Form of Approval: As specified in Division 01 Section "Submittal Procedures."
 - b. Use product specified if Architect cannot make a decision on use of a comparable product request within time allocated.
- D. Basis-of-Design Product Specification Submittal: Comply with requirements in Division 01 Section "Submittal Procedures." Show compliance with requirements.

1.5 QUALITY ASSURANCE

- A. Compatibility of Options: If Contractor is given option of selecting between two or more products for use on Project, product selected shall be compatible with products previously selected, even if previously selected products were also options.
 1. Each contractor is responsible for providing products and construction methods compatible with products and construction methods of other contractors.
 2. If a dispute arises between contractors over concurrently selectable but incompatible products, Architect will determine which products shall be used.

1.6 PRODUCT DELIVERY, STORAGE, AND HANDLING

- A. Deliver, store, and handle products using means and methods that will prevent damage, deterioration, and loss, including theft. Comply with manufacturer's written instructions.
- B. Delivery and Handling:
 - 1. Schedule delivery to minimize long-term storage at Project site and to prevent overcrowding of construction spaces.
 - 2. Coordinate delivery with installation time to ensure minimum holding time for items that are flammable, hazardous, easily damaged, or sensitive to deterioration, theft, and other losses.
 - 3. Deliver products to Project site in an undamaged condition in manufacturer's original sealed container or other packaging system, complete with labels and instructions for handling, storing, unpacking, protecting, and installing.
 - 4. Inspect products on delivery to ensure compliance with the Contract Documents and to ensure that products are undamaged and properly protected.
- C. Storage:
 - 1. Store products to allow for inspection and measurement of quantity or counting of units.
 - 2. Store materials in a manner that will not endanger Project structure.
 - 3. Store products that are subject to damage by the elements, under cover in a weathertight enclosure above ground, with ventilation adequate to prevent condensation.
 - 4. Store cementitious products and materials on elevated platforms.
 - 5. Comply with product manufacturer's written instructions for temperature, humidity, ventilation, and weather-protection requirements for storage.
 - 6. Protect stored products from damage and liquids from freezing.
 - 7. Provide a secure location and enclosure at Project site for storage of materials and equipment by Owner's construction forces. Coordinate location with Owner.

1.7 ENVIRONMENTAL REQUIREMENTS

- A. General: Interior construction materials, finishes, and furnishings, including partitions, partition coverings, flooring, floor coverings, wall covering, ceiling tiles, adhesives, sealants, glazes, paints, and similar materials shall be designed, manufactured, handled, and installed in such a manner to produce least harmful or annoying effect on occupants of building.
 - 1. Written notification of these requirements to suppliers of these materials shall be made to assure that compliance is obtained from manufacturers.
 - 2. Materials must emit lowest, yet technologically achievable emissions of particles and chemical vapors. As a minimum, materials shall meet emission rate standards set forth below. Emission rate calculations shall comply with the requirements in the Owner's solicitation documents.

1.8 PRODUCT WARRANTIES

- A. Warranties specified in other Sections shall be in addition to, and run concurrent with, other warranties required by the Contract Documents. Manufacturer's disclaimers and limitations on product warranties do not relieve Contractor of obligations under requirements of the Contract Documents.
1. Manufacturer's Warranty: Preprinted written warranty published by individual manufacturer for a particular product and specifically endorsed by manufacturer to Owner.
 2. Special Warranty: Written warranty required by or incorporated into the Contract Documents, either to extend time limit provided by manufacturer's warranty or to provide more rights for Owner.
- B. Special Warranties: Prepare a written document that contains appropriate terms and identification, ready for execution. Submit a draft for approval before final execution.
1. Manufacturer's Standard Form: Modified to include Project-specific information and properly executed.
 2. Specified Form: When specified forms are included with the Specifications, prepare a written document using appropriate form properly executed.
 3. Refer to Divisions 02 through 49 Sections for specific content requirements and particular requirements for submitting special warranties.
- C. Submittal Time: Comply with requirements in Division 01 Section "Closeout Procedures."

PART 2 - PRODUCTS

2.1 PRODUCT SELECTION PROCEDURES

- A. General Product Requirements: Provide products that comply with the Contract Documents, that are undamaged and, unless otherwise indicated, that are new at time of installation.
1. Provide products complete with accessories, trim, finish, fasteners, and other items needed for a complete installation and indicated use and effect.
 2. Standard Products: If available, and unless custom products or nonstandard options are specified, provide standard products of types that have been produced and used successfully in similar situations on other projects.
 3. Owner reserves the right to limit selection to products with warranties not in conflict with requirements of the Contract Documents.
 4. Where products are accompanied by the term "as selected," Architect will make selection.
 5. Where products are accompanied by the term "match sample," sample to be matched is Architect's.
 6. Descriptive, performance, and reference standard requirements in the Specifications establish "salient characteristics" of products.
 7. Or Equal: Where products are specified by name and accompanied by the term "or equal" or "or approved equal" or "or approved," comply with provisions in

Part 2 "Comparable Products" Article to obtain approval for use of an unnamed product.

B. Product Selection Procedures:

1. Product: Where Specifications name a single product and manufacturer, provide the named product that complies with requirements.
2. Manufacturer/Source: Where Specifications name a single manufacturer or source, provide a product by the named manufacturer or source that complies with requirements.
3. Products: Where Specifications include a list of names of both products and manufacturers, provide one of the products listed that complies with requirements.
4. Manufacturers: Where Specifications include a list of manufacturers' names, provide a product by one of the manufacturers listed that complies with requirements.
5. Available Products: Where Specifications include a list of names of both products and manufacturers, provide one of the products listed, or an unnamed product, that complies with requirements. Comply with provisions in Part 2 "Comparable Products" Article for consideration of an unnamed product.
6. Available Manufacturers: Where Specifications include a list of manufacturers, provide a product by one of the manufacturers listed, or an unnamed manufacturer, that complies with requirements. Comply with provisions in Part 2 "Comparable Products" Article for consideration of an unnamed product.
7. Product Options: Where Specifications indicate that sizes, profiles, and dimensional requirements on Drawings are based on a specific product or system, provide the specified product or system. Comply with provisions in Part 2 "Product Substitutions" Article for consideration of an unnamed product or system.
8. Basis-of-Design Product: Where Specifications name a product and include a list of manufacturers, provide the specified product or a comparable product by one of the other named manufacturers. Drawings and Specifications indicate sizes, profiles, dimensions, and other characteristics that are based on the product named. Comply with provisions in Part 2 "Comparable Products" Article for consideration of an unnamed product by the other named manufacturers.
9. Visual Matching Specification: Where Specifications require matching an established Sample, select a product that complies with requirements and matches Architect's sample. Architect's decision will be final on whether a proposed product matches.
 - a. If no product available within specified category matches and complies with other specified requirements, comply with provisions in Part 2 "Product Substitutions" Article for proposal of product.
10. Visual Selection Specification: Where Specifications include the phrase "as selected from manufacturer's colors, patterns, textures" or a similar phrase, select a product that complies with other specified requirements.
 - a. Standard Range: Where Specifications include the phrase "standard range of colors, patterns, textures" or similar phrase, Architect will select color,

pattern, density, or texture from manufacturer's product line that does not include premium items.

- b. Full Range: Where Specifications include the phrase "full range of colors, patterns, textures" or similar phrase, Architect will select color, pattern, density, or texture from manufacturer's product line that includes both standard and premium items.

2.2 PRODUCT SUBSTITUTIONS

- A. Timing: Architect will consider requests for substitution if received within 14 days prior to receipt of bids. Requests received after that time may be considered or rejected at discretion of Architect.
- B. Conditions: Architect will consider Contractor's request for substitution when the following conditions are satisfied. If the following conditions are not satisfied, Architect will return requests without action, except to record noncompliance with these requirements:
 1. Requested substitution offers Owner a substantial advantage in cost, time, energy conservation, or other considerations, after deducting additional responsibilities Owner must assume. Owner's additional responsibilities may include compensation to Architect for redesign and evaluation services, increased cost of other construction by Owner, and similar considerations.
 2. Requested substitution does not require extensive revisions to the Contract Documents.
 3. Requested substitution is consistent with the Contract Documents and will produce indicated results.
 4. Substitution request is fully documented and properly submitted.
 5. Requested substitution will not adversely affect Contractor's Construction Schedule.
 6. Requested substitution has received necessary approvals of authorities having jurisdiction.
 7. Requested substitution is compatible with other portions of the Work.
 8. Requested substitution has been coordinated with other portions of the Work.
 9. Requested substitution provides specified warranty.

2.3 COMPARABLE PRODUCTS

- A. Conditions: Architect will consider Contractor's request for comparable product when the following conditions are satisfied. If the following conditions are not satisfied, Architect will return requests without action, except to record noncompliance with these requirements:
 1. Evidence that the proposed product does not require extensive revisions to the Contract Documents that it is consistent with the Contract Documents and will produce the indicated results, and that it is compatible with other portions of the Work.
 2. Detailed comparison of significant qualities of proposed product with those named in the Specifications. Significant qualities include attributes such as

performance, weight, size, durability, visual effect, and specific features and requirements indicated.

3. Evidence that proposed product provides specified warranty.
4. List of similar installations for completed projects with project names and addresses and names and addresses of architects and owners, if requested.
5. Samples, if requested.

PART 3 - EXECUTION (Not Used)

END OF SECTION 016000

SECTION 017300 - EXECUTION

PART 1 - GENERAL

1.1 RELATED DOCUMENTS

- A. Drawings and general provisions of the Contract, including General and Supplementary Conditions and other Division 01 Specification Sections, apply to this Section.

1.2 SUMMARY

- A. Section includes general administrative and procedural requirements governing execution of the Work including, but not limited to, the following:
 - 1. Construction layout.
 - 2. Field engineering.
 - 3. Installation of the Work.
 - 4. Cutting and patching.
 - 5. Coordination of Owner-installed products.
 - 6. Progress cleaning.
 - 7. Starting and adjusting.
 - 8. Protection of installed construction.
 - 9. Correction of the Work.
- B. Related Sections:
 - 1. Division 01 Section "Submittal Procedures."
 - 2. Division 01 Section "Closeout Procedures."
 - 3. Division 02 Section "Selective Demolition" for demolition and removal of selected portions of the building.

1.3 DEFINITIONS

- A. Cutting: Removal of in-place construction necessary to permit installation or performance of other work.
- B. Patching: Fitting and repair work required to restore construction to original conditions after installation of other work.

1.4 QUALITY ASSURANCE

- A. Cutting and Patching: Comply with requirements for and limitations on cutting and patching of construction elements.

1. Structural Elements: When cutting and patching structural elements, notify Architect of locations and details of cutting and await directions from the Architect before proceeding. Shore, brace, and support structural element during cutting and patching. Do not cut and patch structural elements in a manner that could change their load-carrying capacity or increase deflection
 2. Operational Elements: Do not cut and patch operating elements and related components in a manner that results in reducing their capacity to perform as intended or that results in increased maintenance or decreased operational life or safety.
 - a. Primary operational systems and equipment.
 - b. Fire separation assemblies.
 - c. Air or smoke barriers.
 - d. Fire-suppression systems.
 - e. Mechanical systems piping and ducts.
 - f. Control systems.
 - g. Communication systems.
 - h. Conveying systems.
 - i. Electrical wiring systems.
 - j. Operating systems of special construction.
 3. Other Construction Elements: Do not cut and patch other construction elements or components in a manner that could change their load-carrying capacity, that results in reducing their capacity to perform as intended, or that results in increased maintenance or decreased operational life or safety.
 4. Visual Elements: Do not cut and patch construction in a manner that results in visual evidence of cutting and patching. Do not cut and patch exposed construction in a manner that would, in Architect's opinion, reduce the building's aesthetic qualities. Remove and replace construction that has been cut and patched in a visually unsatisfactory manner.
- B. Cutting and Patching Conference: Before proceeding, meet at Project site with parties involved in cutting and patching, including mechanical and electrical trades. Review areas of potential interference and conflict. Coordinate procedures and resolve potential conflicts before proceeding.
- C. Manufacturer's Installation Instructions: Obtain and maintain on-site manufacturer's written recommendations and instructions for installation of products and equipment.
- 1.5 WARRANTY
- A. Existing Warranties: Remove, replace, patch, and repair materials and surfaces cut or damaged during installation or cutting and patching operations, by methods and with materials so as not to void existing warranties.

PART 2 - PRODUCTS

2.1 MATERIALS

- A. General: Comply with requirements specified in other Sections.
- B. In-Place Materials: Use materials for patching identical to in-place materials. For exposed surfaces, use materials that visually match in-place adjacent surfaces to the fullest extent possible.
 - 1. If identical materials are unavailable or cannot be used, use materials that, when installed, will provide a match acceptable to the Architect for the visual and functional performance of in-place materials.

PART 3 - EXECUTION

3.1 EXAMINATION

- A. Existing Conditions: The contractor must proceed with extreme care. The location of concealed piping and wiring related to active mechanical, electrical, plumbing, fire protection, detention and security systems and other utilities related to emergency and life safety systems may not be accurately identified, or identified on the contract documents. Before proceeding with any work the contractor is required to take every reasonable precaution prior to cutting or removal of existing to verify the owners operations will not be disrupted.
- B. Examination and Acceptance of Conditions: Before proceeding with each component of the Work, examine substrates, areas, and conditions, with Installer or Applicator present where indicated, for compliance with requirements for installation tolerances and other conditions affecting performance. Record observations.
 - 1. Written Report: Where a written report listing conditions detrimental to performance of the Work is required by other Sections, include the following:
 - a. Description of the Work.
 - b. List of detrimental conditions, including substrates.
 - c. List of unacceptable installation tolerances.
 - d. Recommended corrections.
 - 2. Verify compatibility with and suitability of substrates, including compatibility with existing finishes or primers.
 - 3. Examine roughing-in for detention, security and electrical systems to verify actual locations of connections before equipment and fixture installation.
 - 4. Examine walls, and floors, for suitable conditions where products and systems are to be installed.
 - 5. Proceed with installation only after unsatisfactory conditions have been corrected. Proceeding with the Work indicates acceptance of surfaces and conditions.

3.2 PREPARATION

- A. Field Measurements: Take field measurements as required to fit the Work properly. Recheck measurements before installing each product. Where portions of the Work are indicated to fit to other construction, verify dimensions of other construction by field measurements before fabrication. Coordinate fabrication schedule with construction progress to avoid delaying the Work.
- B. Space Requirements: Verify space requirements and dimensions of items shown diagrammatically on Drawings.
- C. Review of Contract Documents and Field Conditions: Immediately on discovery of the need for clarification of the Contract Documents caused by differing field conditions outside the control of the Contractor, submit a request for information to Architect according to requirements in Division 01 Section "Project Management and Coordination."

3.3 INSTALLATION

- A. General: Locate the Work and components of the Work accurately, in correct alignment and elevation, as indicated.
 - 1. Make vertical work plumb and make horizontal work level.
 - 2. Where space is limited, install components to maximize space available for maintenance and ease of removal for replacement.
 - 3. Conceal wiring in finished areas, unless otherwise indicated.
- B. Comply with manufacturer's written instructions and recommendations for installing products in applications indicated.
- C. Install products at the time and under conditions that will ensure the best possible results. Maintain conditions required for product performance until Substantial Completion.
- D. Conduct construction operations so no part of the Work is subjected to damaging operations or loading in excess of that expected during normal conditions of occupancy.
- E. Tools and Equipment: Do not use tools or equipment that produce harmful noise levels.
- F. Templates: Obtain and distribute to the parties involved templates for work specified to be factory prepared and field installed. Check Shop Drawings of other work to confirm that adequate provisions are made for locating and installing products to comply with indicated requirements.
- G. Attachment: Provide blocking and attachment plates and anchors and fasteners of adequate size and number to securely anchor each component in place, accurately located and aligned with other portions of the Work. Where size and type of attachments are not indicated, verify size and type required for load conditions.

1. Mounting Heights: Where mounting heights are not indicated, mount components at heights directed by Architect.
 2. Allow for building movement, including thermal expansion and contraction.
 3. Coordinate installation of anchorages. Furnish setting drawings, templates, and directions for installing anchorages, including sleeves, concrete inserts, anchor bolts, and items with integral anchors, that are to be embedded in concrete or masonry. Deliver such items to Project site in time for installation.
- H. Joints: Make joints of uniform width. Where joint locations in exposed work are not indicated, arrange joints for the best visual effect. Fit exposed connections together to form hairline joints.
- I. Hazardous Materials: Use products, cleaners, and installation materials that are not considered hazardous.

3.4 PROGRESS CLEANING

- A. General: Clean Project site and work areas daily, including common areas. Enforce requirements strictly. Dispose of materials lawfully.
1. Comply with requirements in NFPA 241 for removal of combustible waste materials and debris.
 2. Do not hold waste materials more than seven days during normal weather or three days if the temperature is expected to rise above 80 deg F.
 3. Containerize hazardous and unsanitary waste materials separately from other waste. Mark containers appropriately and dispose of legally, according to regulations.
 - a. Utilize containers intended for holding waste materials of type to be stored.
 4. Coordinate progress cleaning for joint-use areas where more than one installer has worked.
- B. Site: Maintain Project site free of waste materials and debris.
- C. Work Areas: Clean areas where work is in progress to the level of cleanliness necessary for proper execution of the Work.
1. Remove liquid spills promptly.
 2. Where dust would impair proper execution of the Work, broom-clean or vacuum the entire work area, as appropriate.
- D. Installed Work: Keep installed work clean. Clean installed surfaces according to written instructions of manufacturer or fabricator of product installed, using only cleaning materials specifically recommended. If specific cleaning materials are not recommended, use cleaning materials that are not hazardous to health or property and that will not damage exposed surfaces.
- E. Concealed Spaces: Remove debris from concealed spaces before enclosing the space.

- F. Exposed Surfaces in Finished Areas: Clean exposed surfaces and protect as necessary to ensure freedom from damage and deterioration at time of Substantial Completion.
- G. Waste Disposal: Do not bury or burn waste materials on-site. Do not wash waste materials down sewers or into waterways. Comply with waste disposal requirements in Division 01 Section "Temporary Facilities and Controls
- H. Three paragraphs below reduce or eliminate the need for similar provisions in other Sections. Insert other provisions needed because of unusual Project conditions. Specify unusual provisions for specific work in the individual Section.
- I. During handling and installation, clean and protect construction in progress and adjoining materials already in place. Apply protective covering where required to ensure protection from damage or deterioration at Substantial Completion.
- J. Clean and provide maintenance on completed construction as frequently as necessary through the remainder of the construction period. Adjust and lubricate operable components to ensure operability without damaging effects.
- K. Limiting Exposures: Supervise construction operations to assure that no part of the construction, completed or in progress, is subject to harmful, dangerous, damaging, or otherwise deleterious exposure during the construction period.

3.5 STARTING AND ADJUSTING

- A. Start equipment and operating components to confirm proper operation. Remove malfunctioning units, replace with new units, and retest.
- B. Adjust equipment for proper operation. Adjust operating components for proper operation without binding.
- C. Test each piece of equipment to verify proper operation. Test and adjust controls and safeties. Replace damaged and malfunctioning controls and equipment.

3.6 PROTECTION OF INSTALLED CONSTRUCTION

- A. Provide final protection and maintain conditions that ensure installed Work is without damage or deterioration at time of Substantial Completion.
- B. Comply with manufacturer's written instructions for temperature and relative humidity.

3.7 CORRECTION OF THE WORK

- A. Repair or remove and replace defective construction. Restore damaged substrates and finishes.

1. Repairing includes replacing defective parts, refinishing damaged surfaces, touching up with matching materials, and properly adjusting operating equipment.
- B. Restore permanent facilities used during construction to their specified condition.
- C. Remove and replace damaged surfaces that are exposed to view if surfaces cannot be repaired without visible evidence of repair.
- D. Repair components that do not operate properly. Remove and replace operating components that cannot be repaired.
- E. Remove and replace chipped, scratched, and broken glass or reflective surfaces.

END OF SECTION 017300

SECTION 017390 - CUTTING AND PATCHING

PART 1 - GENERAL

1.1 RELATED DOCUMENTS

- A. Drawings and general provisions of the Contract, including General and Supplementary Conditions and other Division 01 Specification Sections, apply to this Section.

1.2 SUMMARY

- A. This Section includes procedural requirements for cutting and patching.
- B. Related Sections include the following:
 - 1. Divisions 02 through 16 Sections for specific requirements and limitations applicable to cutting and patching individual parts of the Work.

1.3 DEFINITIONS

- A. Cutting: Removal of in-place construction necessary to permit installation or performance of other Work.
- B. Patching: Fitting and repair work required to restore surfaces to original conditions after installation of other Work.

1.4 SUBMITTALS

- A. Cutting and Patching Proposal: Submit a proposal describing procedures at least 10 days before the time cutting and patching will be performed, requesting approval to proceed. Include the following information:
 - 1. Extent: Describe cutting and patching, show how they will be performed, and indicate why they cannot be avoided.
 - 2. Changes to In-Place Construction: Describe anticipated results. Include changes to structural elements and operating components as well as changes in building's appearance and other significant visual elements.
 - 3. Products: List products to be used and firms or entities that will perform the Work.
 - 4. Dates: Indicate when cutting and patching will be performed.
 - 5. Detention, Security and Electrical Systems: List services/systems that cutting and patching procedures will disturb or affect. List services/systems that will be temporarily out of service. Indicate how long services/systems will be disrupted.

6. Structural Elements: Where cutting and patching involve adding reinforcement to structural elements, submit details and engineering calculations showing integration of reinforcement with original structure.
7. Details and calculations shall be prepared by or under direct supervision of, sealed, and signed by professional engineer.
8. Construction Manager's Approval: Obtain approval of cutting and patching proposal before cutting and patching. Approval does not waive right to later require removal and replacement of unsatisfactory work.

1.5 QUALITY ASSURANCE

- A. Where possible, employ original installer or fabricator to perform cutting and patching for weather-exposed and moisture-resistant elements, and exposed-to-view finished surfaces. If impossible to engage original installer or fabricator, engage another recognized experienced and specialized firm acceptable to Architect.
 1. Structural Elements: Do not cut and patch structural elements in a manner that could change their load-carrying capacity or load-deflection ratio.
- B. Operational Elements: Do not cut and patch operating elements and related components in a manner that results in reducing their capacity to perform as intended or that results in increased maintenance or decreased operational life or safety. Operating elements include, but are not limited to:
 1. Primary operational systems and equipment.
 2. Air or smoke barriers.
 3. Fire-suppression systems.
 4. Mechanical systems piping and ducts.
 5. Control systems.
 6. Communication systems.
 7. Conveying systems.
 8. Electrical wiring systems.
 9. Operating systems of special construction in Division 13 Sections.
- C. Miscellaneous Elements: Do not cut and patch miscellaneous elements or related components in a manner that could change their load-carrying capacity, that results in reducing their capacity to perform as intended, or that results in increased maintenance or decreased operational life or safety.
- D. Visual Requirements: Do not cut and patch construction in a manner that results in visual evidence of cutting and patching. Do not cut and patch construction exposed on the exterior or in occupied spaces in a manner that would, in Architect's opinion, reduce the building's aesthetic qualities. Remove and replace construction that has been cut and patched in a visually unsatisfactory manner.
- E. Cutting and Patching Conference: Before proceeding, meet at Project site with parties involved in cutting and patching, including mechanical and electrical trades. Review areas of potential interference and conflict. Coordinate procedures and resolve potential conflicts before proceeding.

1.6 WARRANTY

- A. Existing Warranties: Remove, replace, patch, and repair materials and surfaces cut or damaged during cutting and patching operations, by methods and with materials so as not to void existing warranties.

PART 2 - PRODUCTS

2.1 MATERIALS

- A. General: Comply with requirements specified in other Sections.
- B. In-Place Materials: Use materials identical to in-place materials. For exposed surfaces, use materials that visually match in-place adjacent surfaces to the fullest extent possible.
 - 1. If identical materials are unavailable or cannot be used, use materials that, when installed, will match the visual and functional performance of in-place materials.

PART 3 - EXECUTION

3.1 EXAMINATION

- A. Examine surfaces to be cut and patched and conditions under which cutting and patching are to be performed.
 - 1. Compatibility: Before patching, verify compatibility with and suitability of substrates, including compatibility with in-place finishes or primers.
 - 2. Proceed with installation only after unsafe or unsatisfactory conditions have been corrected.

3.2 PREPARATION

- A. Temporary Support: Provide temporary support of Work to be cut.
- B. Protection: Protect in-place construction during cutting and patching to prevent damage. Provide protection from adverse weather conditions for portions of Project that might be exposed during cutting and patching operations.
- C. Adjoining Areas: Avoid interference with use of adjoining areas or interruption of free passage to adjoining areas.
- D. Existing Security, Detention and Electrical Systems: Where existing services/systems are required to be removed, relocated, or abandoned, bypass such services/systems before cutting to prevent interruption to occupied areas.

3.3 PERFORMANCE

- A. General: Employ skilled workers to perform cutting and patching. Proceed with cutting and patching at the earliest feasible time, and complete without delay.
 - 1. Cut in-place construction to provide for installation of other components or performance of other construction, and subsequently patch as required to restore surfaces to their original condition.

- B. Cutting: Cut in-place construction by sawing, drilling, breaking, chipping, grinding, and similar operations, including excavation, using methods least likely to damage elements retained or adjoining construction. If possible, review proposed procedures with original Installer; comply with original Installer's written recommendations.
 - 1. In general, use hand or small power tools designed for sawing and grinding, not hammering and chopping. Cut holes and slots as small as possible, neatly to size required, and with minimum disturbance of adjacent surfaces. Temporarily cover openings when not in use.
 - 2. Finished Surfaces: Cut or drill from the exposed or finished side into concealed surfaces.
 - 3. Concrete and Masonry: Cut using a cutting machine, such as an abrasive saw or a diamond-core drill.
 - 4. Mechanical and Electrical Services: Cut off pipe or conduit in walls or partitions to be removed. Cap, valve, or plug and seal remaining portion of pipe or conduit to prevent entrance of moisture or other foreign matter after cutting.
 - 5. Proceed with patching after construction operations requiring cutting are complete.

- C. Patching: Patch construction by filling, repairing, refinishing, closing up, and similar operations following performance of other Work. Patch with durable seams that are as invisible as possible. Provide materials and comply with installation requirements specified in other Sections.
 - 1. Inspection: Where feasible, test and inspect patched areas after completion to demonstrate integrity of installation.
 - 2. Exposed Finishes: Restore exposed finishes of patched areas and extend finish restoration into retained adjoining construction in a manner that will eliminate evidence of patching and refinishing.
 - a. Clean piping, conduit, and similar features before applying paint or other finishing materials.
 - b. Restore damaged pipe covering to its original condition.
 - 3. Floors and Walls: Where walls or partitions that are removed extend one finished area into another, patch and repair wall surfaces. Provide an even surface of uniform finish, color, texture, and appearance.
 - a. Where patching occurs in a painted surface, apply primer and intermediate paint coats over the patch and apply final paint coat over entire unbroken surface containing the patch. Provide additional coats until patch blends with adjacent surfaces.

- D. Cleaning: Clean areas and spaces where cutting and patching are performed. Completely remove paint, mortar, oils, putty, and similar materials.

END OF SECTION 017390

SECTION 017419 - CONSTRUCTION WASTE MANAGEMENT AND DISPOSAL

PART 1 - GENERAL

1.1 RELATED DOCUMENTS

- A. Drawings and general provisions of the Contract, including General and Supplementary Conditions and other Division 01 Specification Sections, apply to this Section.

1.2 SUMMARY

- A. Section includes administrative and procedural requirements for the following:
 - 1. Salvaging nonhazardous demolition and construction waste.
 - 2. Recycling nonhazardous demolition and construction waste.
 - 3. Disposing of nonhazardous demolition and construction waste.
- B. Related Requirements:
 - 1. Division 02 Section "Selective Structure Demolition" for disposition of waste resulting from partial demolition of buildings, structures, and site improvements, and for disposition of hazardous waste.
 - 2. Division 04 Section "Unit Masonry" for disposal requirements for masonry waste.

1.3 DEFINITIONS

- A. Construction Waste: Building and site improvement materials and other solid waste resulting from construction, remodeling, renovation, or repair operations. Construction waste includes packaging.
- B. Demolition Waste: Building and site improvement materials resulting from demolition or selective demolition operations.
- C. Disposal: Removal off-site of demolition and construction waste and subsequent sale, recycling, reuse, or deposit in landfill or incinerator acceptable to authorities having jurisdiction.
- D. Recycle: Recovery of demolition or construction waste for subsequent processing in preparation for reuse.
- E. Salvage: Recovery of demolition or construction waste and subsequent sale or reuse in another facility.
- F. Salvage and Reuse: Recovery of demolition or construction waste and subsequent incorporation into the Work.

1.4 PERFORMANCE REQUIREMENTS

- A. General: Achieve end-of-Project rates for salvage/recycling of 75 percent by weight of total non-hazardous solid waste generated by the Work. Practice efficient waste management in the use of materials in the course of the Work. Use all reasonable means to divert construction and demolition waste from landfills and incinerators. Facilitate recycling and salvage of materials, including the following:

1. Demolition Waste:

- a. Concrete.
- b. Concrete reinforcing steel.
- c. Concrete masonry units.
- d. Structural and miscellaneous steel.
- e. Rough hardware.
- f. Insulation.
- g. Doors and frames.
- h. Door hardware.
- i. Equipment.
- j. Piping.
- k. Supports and hangers.
- l. Valves.
- m. Refrigerants.
- n. Electrical conduit.
- o. Copper wiring.
- p. Lamps.
- q. Ballasts.
- r. Electrical devices.

2. Construction Waste:

- a. Masonry and CMU.
- b. Lumber.
- c. Wood sheet materials.
- d. Metals.
- e. Insulation.
- f. Piping.
- g. Electrical conduit.
- h. Packaging: Regardless of salvage/recycle goal indicated in "General" Paragraph above, salvage or recycle 100 percent of the following uncontaminated packaging materials:
 - 1) Paper.
 - 2) Cardboard.
 - 3) Boxes.
 - 4) Plastic sheet and film.
 - 5) Polystyrene packaging.
 - 6) Wood crates.
 - 7) Plastic pails.

1.5 ACTION SUBMITTALS

- A. Waste Management Plan: Submit plan within 7 days of date established for the Notice to Proceed.

1.6 INFORMATIONAL SUBMITTALS

- A. Waste Reduction Progress Reports: Concurrent with each Application for Payment, submit report. Use Form CWM-7 for construction waste and Form CWM-8 for demolition waste. Include the following information:
 - 1. Material category.
 - 2. Generation point of waste.
 - 3. Total quantity of waste in tons.
 - 4. Quantity of waste salvaged, both estimated and actual in tons.
 - 5. Quantity of waste recycled, both estimated and actual in tons.
 - 6. Total quantity of waste recovered (salvaged plus recycled) in tons.
 - 7. Total quantity of waste recovered (salvaged plus recycled) as a percentage of total waste.
- B. Waste Reduction Calculations: Before request for Substantial Completion, submit calculated end-of-Project rates for salvage, recycling, and disposal as a percentage of total waste generated by the Work.
- C. Records of Donations: Indicate receipt and acceptance of salvageable waste donated to individuals and organizations. Indicate whether organization is tax exempt.
- D. Records of Sales: Indicate receipt and acceptance of salvageable waste sold to individuals and organizations. Indicate whether organization is tax exempt.
- E. Recycling and Processing Facility Records: Indicate receipt and acceptance of recyclable waste by recycling and processing facilities licensed to accept them. Include manifests, weight tickets, receipts, and invoices.
- F. Landfill and Incinerator Disposal Records: Indicate receipt and acceptance of waste by landfills and incinerator facilities licensed to accept them. Include manifests, weight tickets, receipts, and invoices.
- G. Qualification Data: For waste management coordinator.
- H. Statement of Refrigerant Recovery: Signed by refrigerant recovery technician responsible for recovering refrigerant, stating that all refrigerant that was present was recovered and that recovery was performed according to EPA regulations. Include name and address of technician and date refrigerant was recovered.

1.7 QUALITY ASSURANCE

- A. Waste Management Coordinator Qualifications: Experienced firm, with a record of successful waste management coordination of projects with similar requirements, that

employs a LEED-Accredited Professional, certified by the USGBC, as waste management coordinator. Waste management coordinator may also serve as LEED coordinator.

- B. Refrigerant Recovery Technician Qualifications: Certified by EPA-approved certification program.
- C. Regulatory Requirements: Comply with hauling and disposal regulations of authorities having jurisdiction.
- D. Waste Management Conference: Conduct conference at Project site to comply with requirements in Division 01 Section "Project Management and Coordination." Review methods and procedures related to waste management including, but not limited to, the following:
 - 1. Review and discuss waste management plan including responsibilities of waste management coordinator.
 - 2. Review requirements for documenting quantities of each type of waste and its disposition.
 - 3. Review and finalize procedures for materials separation and verify availability of containers and bins needed to avoid delays.
 - 4. Review procedures for periodic waste collection and transportation to recycling and disposal facilities.
 - 5. Review waste management requirements for each trade.

1.8 WASTE MANAGEMENT PLAN

- A. General: Develop a waste management plan according to ASTM E 1609 and requirements in this Section. Plan shall consist of waste identification, waste reduction work plan, and cost/revenue analysis. Distinguish between demolition and construction waste. Indicate quantities by weight or volume, but use same units of measure throughout waste management plan.
- B. Waste Identification: Indicate anticipated types and quantities of demolition site-clearing and construction waste generated by the Work. Use Form CWM-1 for construction waste and Form CWM-2 for demolition waste. Include estimated quantities and assumptions for estimates.
- C. Waste Reduction Work Plan: List each type of waste and whether it will be salvaged, recycled, or disposed of in landfill or incinerator. Use Form CWM-3 for construction waste and Form CWM-4 for demolition waste. Include points of waste generation, total quantity of each type of waste, quantity for each means of recovery, and handling and transportation procedures.
 - 1. Salvaged Materials for Reuse: For materials that will be salvaged and reused in this Project, describe methods for preparing salvaged materials before incorporation into the Work.
 - 2. Salvaged Materials for Sale: For materials that will be sold to individuals and organizations, include list of their names, addresses, and telephone numbers.

3. Salvaged Materials for Donation: For materials that will be donated to individuals and organizations, include list of their names, addresses, and telephone numbers.
 4. Recycled Materials: Include list of local receivers and processors and type of recycled materials each will accept. Include names, addresses, and telephone numbers.
 5. Disposed Materials: Indicate how and where materials will be disposed of. Include name, address, and telephone number of each landfill and incinerator facility.
 6. Handling and Transportation Procedures: Include method that will be used for separating recyclable waste including sizes of containers, container labeling, and designated location where materials separation will be performed.
- D. Cost/Revenue Analysis: Indicate total cost of waste disposal as if there was no waste management plan and net additional cost or net savings resulting from implementing waste management plan. Use Form CWM-5 for construction waste and Form CWM-6 for demolition waste. Include the following:
1. Total quantity of waste.
 2. Estimated cost of disposal (cost per unit). Include hauling and tipping fees and cost of collection containers for each type of waste.
 3. Total cost of disposal (with no waste management).
 4. Revenue from salvaged materials.
 5. Revenue from recycled materials.
 6. Savings in hauling and tipping fees by donating materials.
 7. Savings in hauling and tipping fees that are avoided.
 8. Handling and transportation costs. Include cost of collection containers for each type of waste.
 9. Net additional cost or net savings from waste management plan.

PART 2 - PRODUCTS (Not Used)

PART 3 - EXECUTION

3.1 PLAN IMPLEMENTATION

- A. General: Implement approved waste management plan. Provide handling, containers, storage, signage, transportation, and other items as required to implement waste management plan during the entire duration of the Contract.
 1. Comply with operation, termination, and removal requirements in Division 01 Section "Temporary Facilities and Controls."
- B. Waste Management Coordinator: Engage a waste management coordinator to be responsible for implementing, monitoring, and reporting status of waste management work plan. Coordinator shall be present at Project site full time for duration of Project.

- C. Training: Train workers, subcontractors, and suppliers on proper waste management procedures, as appropriate for the Work.
 - 1. Distribute waste management plan to everyone concerned within three days of submittal return.
 - 2. Distribute waste management plan to entities when they first begin work on-site. Review plan procedures and locations established for salvage, recycling, and disposal.
- D. Site Access and Temporary Controls: Conduct waste management operations to ensure minimum interference with roads, streets, walks, walkways, and other adjacent occupied and used facilities.
 - 1. Designate and label specific areas on Project site necessary for separating materials that are to be salvaged, recycled, reused, donated, and sold.
 - 2. Comply with Division 01 Section "Temporary Facilities and Controls" for controlling dust and dirt, environmental protection, and noise control.
- E. Waste Management in Historic Zones or Areas: Hauling equipment and other materials shall be of sizes that clear surfaces within historic spaces, areas, rooms, and openings, by 12 inches or more.

3.2 SALVAGING DEMOLITION WASTE

- A. Salvaged Items for Reuse in the Work: Salvage items for reuse and handle as follows:
 - 1. Clean salvaged items.
 - 2. Pack or crate items after cleaning. Identify contents of containers with label indicating elements, date of removal, quantity, and location where removed.
 - 3. Store items in a secure area until installation.
 - 4. Protect items from damage during transport and storage.
 - 5. Install salvaged items to comply with installation requirements for new materials and equipment. Provide connections, supports, and miscellaneous materials necessary to make items functional for use indicated.
- B. Salvaged Items for Sale and Donation: Not permitted on Project site.
- C. Salvaged Items for Owner's Use: Salvage items for Owner's use and handle as follows:
 - 1. Clean salvaged items.
 - 2. Pack or crate items after cleaning. Identify contents of containers with label indicating elements, date of removal, quantity, and location where removed.
 - 3. Store items in a secure area until delivery to Owner.
 - 4. Transport items to Owner's storage area off-site designated by Owner.
 - 5. Protect items from damage during transport and storage.
- D. Doors and Hardware: Brace open end of door frames. Except for removing door closers, leave door hardware attached to doors.

- E. Equipment: Drain tanks, piping, and fixtures. Seal openings with caps or plugs. Protect equipment from exposure to weather.
- F. Plumbing Fixtures: Separate by type and size.
- G. Lighting Fixtures: Separate lamps by type and protect from breakage.
- H. Electrical Devices: Separate switches, receptacles, switchgear, transformers, meters, panelboards, circuit breakers, and other devices by type.

3.3 RECYCLING DEMOLITION AND CONSTRUCTION WASTE, GENERAL

- A. General: Recycle paper and beverage containers used by on-site workers.
- B. Recycling Incentives: Revenues, savings, rebates, tax credits, and other incentives received for recycling waste materials shall accrue to Contractor.
- C. Preparation of Waste: Prepare and maintain recyclable waste materials according to recycling or reuse facility requirements. Maintain materials free of dirt, adhesives, solvents, petroleum contamination, and other substances deleterious to the recycling process.
- D. Procedures: Separate recyclable waste from other waste materials, trash, and debris. Separate recyclable waste by type at Project site to the maximum extent practical according to approved construction waste management plan.
 - 1. Provide appropriately marked containers or bins for controlling recyclable waste until removed from Project site. Include list of acceptable and unacceptable materials at each container and bin.
 - a. Inspect containers and bins for contamination and remove contaminated materials if found.
 - 2. Stockpile processed materials on-site without intermixing with other materials. Place, grade, and shape stockpiles to drain surface water. Cover to prevent windblown dust.
 - 3. Stockpile materials away from construction area. Do not store within drip line of remaining trees.
 - 4. Store components off the ground and protect from the weather.
 - 5. Remove recyclable waste from Owner's property and transport to recycling receiver or processor.

3.4 RECYCLING DEMOLITION WASTE

- A. Concrete: Remove reinforcement and other metals from concrete and sort with other metals.
 - 1. Pulverize concrete to maximum 4-inch size.
 - 2. Crush concrete and screen for use as satisfactory soil for fill or subbase.

- B. Masonry: Remove metal reinforcement, anchors, and ties from masonry and sort with other metals.
 - 1. Pulverize masonry to maximum 4-inch size.
 - a. Crush masonry and screen for use as general fill or subbase.
 - b. Crush masonry and screen for use as mineral mulch.
 - 2. Clean and stack undamaged, whole masonry units on wood pallets.
- C. Wood Materials: Sort and stack members according to size, type, and length. Separate lumber, engineered wood products, panel products, and treated wood materials.
- D. Metals: Separate metals by type.
 - 1. Structural Steel: Stack members according to size, type of member, and length.
 - 2. Remove and dispose of bolts, nuts, washers, and other rough hardware.
- E. Gypsum Board: Stack large clean pieces on wood pallets or in container and store in a dry location. Remove edge trim and sort with other metals. Remove and dispose of fasteners.
- F. Metal Suspension System: Separate metal members including trim, and other metals from acoustical panels, tile, and sort with other metals.
- G. Piping: Reduce piping to straight lengths and store by type and size. Separate supports, hangers, valves, sprinklers, and other components by type and size.
- H. Conduit: Reduce conduit to straight lengths and store by type and size.

3.5 RECYCLING CONSTRUCTION WASTE

- A. Packaging:
 - 1. Cardboard and Boxes: Break down packaging into flat sheets. Bundle and store in a dry location.
 - 2. Polystyrene Packaging: Separate and bag materials.
 - 3. Pallets: As much as possible, require deliveries using pallets to remove pallets from Project site. For pallets that remain on-site, break down pallets into component wood pieces and comply with requirements for recycling wood.
 - 4. Crates: Break down crates into component wood pieces and comply with requirements for recycling wood.
- B. Wood Materials:
 - 1. Clean Cut-Offs of Lumber: Grind or chip into small pieces.
 - 2. Clean Sawdust: Bag sawdust that does not contain painted or treated wood.

3.6 DISPOSAL OF WASTE

- A. General: Except for items or materials to be salvaged, recycled, or otherwise reused, remove waste materials from Project site and legally dispose of them in a landfill or incinerator acceptable to authorities having jurisdiction.
 - 1. Except as otherwise specified, do not allow waste materials that are to be disposed of accumulate on-site.
 - 2. Remove and transport debris in a manner that will prevent spillage on adjacent surfaces and areas.
- B. Burning: Do not burn waste materials.
- C. Burning: Burning of waste materials is permitted only at designated areas on Owner's property, provided required permits are obtained. Provide full-time monitoring for burning materials until fires are extinguished.
- D. Disposal: Remove waste materials and dispose of at designated spoil areas on Owner's property.
- E. Disposal: Remove waste materials from Owner's property and legally dispose of them.

END OF SECTION 017419

SECTION 017700 - CLOSEOUT PROCEDURES

PART 1 - GENERAL

1.1 RELATED DOCUMENTS

- A. Drawings and general provisions of the Contract, including General and Supplementary Conditions and other Division 01 Specification Sections, apply to this Section.

1.2 SUMMARY

- A. Section includes administrative and procedural requirements for contract closeout, including, but not limited to, the following:
 - 1. Substantial Completion procedures.
 - 2. Final completion procedures.
 - 3. Warranties.
 - 4. Final cleaning.
 - 5. Repair of the Work.
- B. Related Requirements:
 - 1. Division 01 Section "Execution" for progress cleaning of Project site.
 - 2. Division 01 Section "Operation and Maintenance Data" for operation and maintenance manual requirements.
 - 3. Division 01 Section "Project Record Documents" for submitting record Drawings, record Specifications, and record Product Data.
 - 4. Divisions 02 through 32 Sections for specific closeout and special cleaning requirements for the Work in those Sections.

1.3 ACTION SUBMITTALS

- A. Product Data: For cleaning agents.
- B. Contractor's List of Incomplete Items: Initial submittal at Substantial Completion.
- C. Certified List of Incomplete Items: Final submittal at Final Completion.

1.4 CLOSEOUT SUBMITTALS

- A. Certificates of Release: From authorities having jurisdiction.
- B. Certificate of Insurance: For continuing coverage.

1.5 MAINTENANCE MATERIAL SUBMITTALS

- A. Schedule of Maintenance Material Items: For maintenance material submittal items specified in other Sections.

1.6 SUBSTANTIAL COMPLETION PROCEDURES

- A. Contractor's List of Incomplete Items: Prepare and submit a list of items to be completed and corrected (Contractor's punch list), indicating the value of each item on the list and reasons why the Work is incomplete.

- B. Submittals Prior to Substantial Completion: Complete the following a minimum of 14 days prior to requesting inspection for determining date of Substantial Completion. List items below that are incomplete at time of request.

1. Certificates of Release: Obtain and submit releases from authorities having jurisdiction permitting Owner unrestricted use of the Work and access to services and utilities. Include occupancy permits, operating certificates, and similar releases.
2. Submit closeout submittals specified in other Division 01 Sections, including project record documents, operation and maintenance manuals, damage, , and similar final record information.
3. Submit closeout submittals specified in individual Divisions 02 through 16 Sections, including specific warranties, workmanship bonds, maintenance service agreements, final certifications, and similar documents.
4. Submit maintenance material submittals specified in individual Divisions 02 through 16 Sections, including tools, spare parts, extra materials, and similar items, and deliver to location designated by Construction Manager. Label with manufacturer's name and model number where applicable.
 - a. Schedule of Maintenance Material Items: Prepare and submit schedule of maintenance material submittal items, including name and quantity of each item and name and number of related Specification Section. Obtain Construction Manager's signature for receipt of submittals.
5. Submit test/adjust records.
6. Submit changeover information related to Owner's occupancy, use, operation, and maintenance.

- C. Procedures Prior to Substantial Completion: Complete the following a minimum of 14 days prior to requesting inspection for determining date of Substantial Completion. List items below that are incomplete at time of request.

1. Advise Owner of pending insurance changeover requirements.
2. Make final changeover of permanent locks and deliver keys to Owner. Advise Owner's personnel of changeover in security provisions.
3. Complete startup and testing of systems and equipment.
4. Perform preventive maintenance on equipment used prior to Substantial Completion.

5. Instruct Owner's personnel in operation, adjustment, and maintenance of products, equipment, and systems.
6. Terminate and remove temporary facilities from Project site, along with mockups, construction tools, and similar elements.
7. Complete final cleaning requirements, including touchup painting.
8. Touch up and otherwise repair and restore marred exposed finishes to eliminate visual defects.

D. Inspection: Submit a written request for inspection to determine Substantial Completion a minimum of 14 days prior to date the work will be completed and ready for final inspection and tests. On receipt of request, Construction Manager will either proceed with inspection or notify Contractor of unfulfilled requirements. Architect will prepare the Certificate of Substantial Completion after inspection or will notify Contractor of items, either on Contractor's list or additional items identified by Architect, that must be completed or corrected before certificate will be issued.

1. Reinspection: Request reinspection when the Work identified in previous inspections as incomplete is completed or corrected.
 - a. Architect and Construction Manager will make 1 repeat inspection. Should additional reinspections be required, Contractor shall reimburse Owner for time spent in conducting additional inspections at rate of 2.9 times rate of Direct Personnel Expense (DPE). Direct Personnel Expense is defined as direct salaries of Architect's and Construction Manager's personnel engaged on Project and portion of costs of mandatory, and customary contributions and benefits related thereto, including employment taxes and other statutory employee benefits, insurance, sick leave, holidays, vacations, pensions, and similar contributions and benefits.
2. Results of completed inspection will form the basis of requirements for final completion.

1.7 FINAL COMPLETION PROCEDURES

A. Submittals Prior to Final Completion: Before requesting final inspection for determining final completion, complete the following:

1. Submit a final Application for Payment according to Payment Procedures.
2. Certified List of Incomplete Items: Submit certified copy of Architect's Substantial Completion inspection list of items to be completed or corrected (punch list), endorsed and dated by Architect. Certified copy of the list shall state that each item has been completed or otherwise resolved for acceptance.
3. Certificate of Insurance: Submit evidence of final, continuing insurance coverage complying with insurance requirements.
4. Submit consent of surety to final payment.
5. Submit final liquidated damages settlement statement.

B. Inspection: Submit a written request for final inspection to determine acceptance a minimum of 10 days prior to date the work will be completed and ready for final inspection and tests. On receipt of request, Architect and Construction Manager will

either proceed with inspection or notify Contractor of unfulfilled requirements. Architect will prepare a final Certificate for Payment after inspection or will notify Contractor of construction that must be completed or corrected before certificate will be issued.

1. Reinspection: Request reinspection when the Work identified in previous inspections as incomplete is completed or corrected.
 - a. Architect and Construction Manager will make 1 repeat inspection. Should additional reinspections be required, Contractor shall reimburse Owner for time spent in conducting additional inspections at rate of 2.9 times rate of Direct Personnel Expense (DPE). Direct Personnel Expense is defined as direct salaries of Architect's and Construction Manager's personnel engaged on Project and portion of costs of mandatory, and customary contributions and benefits related thereto, including employment taxes and other statutory employee benefits, insurance, sick leave, holidays, vacations, pensions, and similar contributions and benefits.

1.8 LIST OF INCOMPLETE ITEMS (PUNCH LIST)

- A. Organization of List: Include name and identification of each space and area affected by construction operations for incomplete items and items needing correction including, if necessary, areas disturbed by Contractor that are outside the limits of construction.
 1. Organize list of spaces in sequential order, starting from lowest floor to highest floor.
 2. Organize items applying to each space by major element.
 3. Include the following information at the top of each page:
 - a. Project name.
 - b. Date.
 - c. Name of Architect and Construction Manager.
 - d. Name of Contractor.
 - e. Page number.
 4. Submit list of incomplete items in the following format:
 - a. MS Excel electronic file. Architect, through Construction Manager, will return annotated file.

1.9 SUBMITTAL OF PROJECT WARRANTIES

- A. Time of Submittal: Submit written warranties on request of Architect for designated portions of the Work where commencement of warranties other than date of Substantial Completion is indicated, or when delay in submittal of warranties might limit Owner's rights under warranty.
- B. Partial Occupancy: Submit properly executed warranties within 15 days of completion of designated portions of the Work that are completed and occupied or used by Owner during construction period by separate agreement with Contractor.

- C. Organize warranty documents into an orderly sequence based on the table of contents of Project Manual.
 - 1. Bind warranties and bonds in heavy-duty, three-ring, vinyl-covered, loose-leaf binders, thickness as necessary to accommodate contents, and sized to receive 8-1/2-by-11-inch paper.
 - 2. Provide heavy paper dividers with plastic-covered tabs for each separate warranty. Mark tab to identify the product or installation. Provide a typed description of the product or installation, including the name of the product and the name, address, and telephone number of Installer.
 - 3. Identify each binder on the front and spine with the typed or printed title "WARRANTIES," Project name, and name of Contractor.
 - 4. Warranty Electronic File: Scan warranties and bonds and assemble complete warranty and bond submittal package into a single indexed electronic PDF file with links enabling navigation to each item. Provide bookmarked table of contents at beginning of document.

- D. Provide additional copies of each warranty to include in operation and maintenance manuals.

PART 2 - PRODUCTS

2.1 MATERIALS

- A. Cleaning Agents: Use cleaning materials and agents recommended by manufacturer or fabricator of the surface to be cleaned. Do not use cleaning agents that are potentially hazardous to health or property or that might damage finished surfaces.
 - 1. Refer to solicitation document.

PART 3 - EXECUTION

3.1 FINAL CLEANING

- A. General: Perform final cleaning. Conduct cleaning and waste-removal operations to comply with local laws and ordinances and Federal and local environmental and antipollution regulations.
- B. Cleaning: Employ experienced workers or professional cleaners for final cleaning. Clean each surface or unit to condition expected in an average commercial building cleaning and maintenance program. Comply with manufacturer's written instructions.
 - 1. Complete the following cleaning operations before requesting inspection for certification of Substantial Completion for entire Project or for a designated portion of Project:

- a. Clean Project site, in areas disturbed by construction activities of rubbish, waste material, litter, and other foreign substances.
 - b. Sweep broom clean. Remove petrochemical spills, stains, and other foreign deposits.
 - c. Remove tools, construction equipment, machinery, and surplus material from Project site.
 - d. Clean exposed exterior and interior hard-surfaced finishes to a dirt-free condition, free of stains, films, and similar foreign substances. Avoid disturbing natural weathering of exterior surfaces. Restore reflective surfaces to their original condition.
 - e. Remove debris and surface dust from limited access spaces, including roofs, plenums, shafts, trenches, equipment vaults, manholes, attics, and similar spaces.
 - f. Sweep concrete floors broom clean in unoccupied spaces.
 - g. Clean transparent materials, including mirrors and glass in doors and windows. Remove glazing compounds and other noticeable, vision-obscuring materials. Polish mirrors and glass, taking care not to scratch surfaces.
 - h. Remove labels that are not permanent.
 - i. Wipe surfaces of mechanical and electrical equipment and similar equipment. Remove excess lubrication, paint and mortar droppings, and other foreign substances.
 - j. Replace disposable air filters and clean permanent air filters. Clean exposed surfaces of diffusers, registers, and grills.
 - k. Clean ducts, blowers, and coils if units were operated without filters during construction or that display contamination with particulate matter on inspection.
 - 1) Clean HVAC system in compliance with NADCA Standard 1992-01. Provide written report on completion of cleaning.
 - l. Clean light fixtures, lamps, globes, and reflectors to function with full efficiency.
 - m. Leave Project clean and ready for occupancy.
- C. Construction Waste Disposal: Comply with waste disposal requirements in Division 01 Section "Temporary Facilities and Controls".

3.2 REPAIR OF THE WORK

- A. Complete repair and restoration operations before requesting inspection for determination of Substantial Completion.
- B. Repair or remove and replace defective construction. Repairing includes replacing defective parts, refinishing damaged surfaces, touching up with matching materials, and properly adjusting operating equipment. Where damaged or worn items cannot be repaired or restored, provide replacements. Remove and replace operating components that cannot be repaired. Restore damaged construction and permanent facilities used during construction to specified condition.

1. Remove and replace chipped, scratched, and broken glass, reflective surfaces, and other damaged transparent materials.
2. Touch up and otherwise repair and restore marred or exposed finishes and surfaces. Replace finishes and surfaces that that already show evidence of repair or restoration.
 - a. Do not paint over "UL" and other required labels and identification, including mechanical and electrical nameplates. Remove paint applied to required labels and identification.
3. Replace parts subject to operating conditions during construction that may impede operation or reduce longevity.

END OF SECTION 017700

SECTION 017823 - OPERATION AND MAINTENANCE DATA

PART 1 - GENERAL

1.1 RELATED DOCUMENTS

- A. Drawings and general provisions of the Contract, including General and Supplementary Conditions and other Division 01 Specification Sections, apply to this Section.

1.2 SUMMARY

- A. Section includes administrative and procedural requirements for preparing operation and maintenance manuals, including the following:
 - 1. Operation and maintenance documentation directory manuals.
 - 2. Emergency manuals.
 - 3. Systems and equipment operation manuals.
 - 4. Systems and equipment maintenance manuals.
 - 5. Product maintenance manuals.
- B. Related Requirements:
 - 1. Section 013300 "Submittal Procedures" for submitting copies of submittals for operation and maintenance manuals.

1.3 DEFINITIONS

- A. System: An organized collection of parts, equipment, or subsystems united by regular interaction.
- B. Subsystem: A portion of a system with characteristics similar to a system.

1.4 CLOSEOUT SUBMITTALS

- A. Submit operation and maintenance manuals indicated. Provide content for each manual as specified in individual Specification Sections, and as reviewed and approved at the time of Section submittals. Submit reviewed manual content formatted and organized as required by this Section.
 - 1. Architect will comment on whether content of operation and maintenance submittals is acceptable.
 - 2. Where applicable, clarify and update reviewed manual content to correspond to revisions and field conditions.
- B. Format: Submit operation and maintenance manuals in the following format:

1. Submit by uploading to web-based project software site. Enable reviewer comments on draft submittals.
 2. Submit three paper copies. Architect will return two copies.
- C. Initial Manual Submittal: Submit draft copy of each manual at least 30 days before commencing demonstration and training. Architect will comment on whether general scope and content of manual are acceptable.
- D. Final Manual Submittal: Submit each manual in final form prior to requesting inspection for Substantial Completion and at least 15 days before commencing demonstration and training. Architect will return copy with comments.
1. Correct or revise each manual to comply with Architect's comments. Submit copies of each corrected manual within 15 days of receipt of Architect's comments and prior to commencing demonstration and training.
- E. Comply with Section 017700 "Closeout Procedures" for schedule for submitting operation and maintenance documentation.

1.5 FORMAT OF OPERATION AND MAINTENANCE MANUALS

- A. Manuals, Electronic Files: Submit manuals in the form of a multiple file composite electronic PDF file for each manual type required.
1. Electronic Files: Use electronic files prepared by manufacturer where available. Where scanning of paper documents is required, configure scanned file for minimum readable file size.
 2. File Names and Bookmarks: Bookmark individual documents based on file names. Name document files to correspond to system, subsystem, and equipment names used in manual directory and table of contents. Group documents for each system and subsystem into individual composite bookmarked files, then create composite manual, so that resulting bookmarks reflect the system, subsystem, and equipment names in a readily navigated file tree. Configure electronic manual to display bookmark panel on opening file.
- B. Manuals, Paper Copy: Submit manuals in the form of hard-copy, bound and labeled volumes.
1. Binders: Heavy-duty, three-ring, vinyl-covered, loose-leaf binders, in thickness necessary to accommodate contents, sized to hold 8-1/2-by-11-inch paper; with clear plastic sleeve on spine to hold label describing contents and with pockets inside covers to hold folded oversize sheets.
 - a. If two or more binders are necessary to accommodate data of a system, organize data in each binder into groupings by subsystem and related components. Cross-reference other binders if necessary to provide essential information for proper operation or maintenance of equipment or system.
 - b. Identify each binder on front and spine, with printed title "OPERATION AND MAINTENANCE MANUAL," Project title or name, and subject matter

of contents, and indicate Specification Section number on bottom of spine. Indicate volume number for multiple-volume sets.

2. Dividers: Heavy-paper dividers with plastic-covered tabs for each section of the manual. Mark each tab to indicate contents. Include typed list of products and major components of equipment included in the section on each divider, cross-referenced to Specification Section number and title of Project Manual.
3. Protective Plastic Sleeves: Transparent plastic sleeves designed to enclose diagnostic software storage media for computerized electronic equipment. Enclose title pages and directories in clear plastic sleeves.
4. Supplementary Text: Prepared on 8-1/2-by-11-inch white bond paper.
5. Drawings: Attach reinforced, punched binder tabs on drawings and bind with text.
 - a. If oversize drawings are necessary, fold drawings to same size as text pages and use as foldouts.
 - b. If drawings are too large to be used as foldouts, fold and place drawings in labeled envelopes and bind envelopes in rear of manual. At appropriate locations in manual, insert typewritten pages indicating drawing titles, descriptions of contents, and drawing locations.

1.6 REQUIREMENTS FOR EMERGENCY, OPERATION, AND MAINTENANCE MANUALS

- A. Organization of Manuals: Unless otherwise indicated, organize each manual into a separate section for each system and subsystem, and a separate section for each piece of equipment not part of a system. Each manual shall contain the following materials, in the order listed:
 1. Title page.
 2. Table of contents.
 3. Manual contents.
- B. Title Page: Include the following information:
 1. Subject matter included in manual.
 2. Name and address of Project.
 3. Name and address of Owner.
 4. Date of submittal.
 5. Name and contact information for Contractor.
 6. Name and contact information for Construction Manager.
 7. Name and contact information for Architect.
 8. Name and contact information for Commissioning Authority.
 9. Names and contact information for major consultants to the Architect that designed the systems contained in the manuals.
 10. Cross-reference to related systems in other operation and maintenance manuals.
- C. Table of Contents: List each product included in manual, identified by product name, indexed to the content of the volume, and cross-referenced to Specification Section number in Project Manual.

1. If operation or maintenance documentation requires more than one volume to accommodate data, include comprehensive table of contents for all volumes in each volume of the set.
 - D. Manual Contents: Organize into sets of manageable size. Arrange contents alphabetically by system, subsystem, and equipment. If possible, assemble instructions for subsystems, equipment, and components of one system into a single binder.
 - E. Identification: In the documentation directory and in each operation and maintenance manual, identify each system, subsystem, and piece of equipment with same designation used in the Contract Documents. If no designation exists, assign a designation according to ASHRAE Guideline 4, "Preparation of Operating and Maintenance Documentation for Building Systems."
- 1.7 OPERATION AND MAINTENANCE DOCUMENTATION DIRECTORY MANUAL
- A. Operation and Maintenance Documentation Directory: Prepare a separate manual that provides an organized reference to emergency, operation, and maintenance manuals. List items and their location to facilitate ready access to desired information. Include the following:
 1. List of Systems and Subsystems: List systems alphabetically. Include references to operation and maintenance manuals that contain information about each system.
 2. List of Equipment: List equipment for each system, organized alphabetically by system. For pieces of equipment not part of system, list alphabetically in separate list.
 3. Tables of Contents: Include a table of contents for each emergency, operation, and maintenance manual.
- 1.8 EMERGENCY MANUALS
- A. Emergency Manual: Assemble a complete set of emergency information indicating procedures for use by emergency personnel and by Owner's operating personnel for types of emergencies indicated.
 - B. Content: Organize manual into a separate section for each of the following:
 1. Type of emergency.
 2. Emergency instructions.
 3. Emergency procedures.
 - C. Type of Emergency: Where applicable for each type of emergency indicated below, include instructions and procedures for each system, subsystem, piece of equipment, and component:
 1. Fire.
 2. Flood.
 3. Gas leak.

4. Water leak.
 5. Power failure.
 6. Water outage.
 7. System, subsystem, or equipment failure.
 8. Chemical release or spill.
- D. Emergency Instructions: Describe and explain warnings, trouble indications, error messages, and similar codes and signals. Include responsibilities of Owner's operating personnel for notification of Installer, supplier, and manufacturer to maintain warranties.
- E. Emergency Procedures: Include the following, as applicable:
1. Instructions on stopping.
 2. Shutdown instructions for each type of emergency.
 3. Operating instructions for conditions outside normal operating limits.
 4. Required sequences for electric or electronic systems.
 5. Special operating instructions and procedures.

1.9 SYSTEMS AND EQUIPMENT OPERATION MANUALS

- A. Systems and Equipment Operation Manual: Assemble a complete set of data indicating operation of each system, subsystem, and piece of equipment not part of a system. Include information required for daily operation and management, operating standards, and routine and special operating procedures.
1. Engage a factory-authorized service representative to assemble and prepare information for each system, subsystem, and piece of equipment not part of a system.
 2. Prepare a separate manual for each system and subsystem, in the form of an instructional manual for use by Owner's operating personnel.
- B. Content: In addition to requirements in this Section, include operation data required in individual Specification Sections and the following information:
1. System, subsystem, and equipment descriptions. Use designations for systems and equipment indicated on Contract Documents.
 2. Performance and design criteria if Contractor has delegated design responsibility.
 3. Operating standards.
 4. Operating procedures.
 5. Operating logs.
 6. Wiring diagrams.
 7. Control diagrams.
 8. Piped system diagrams.
 9. Precautions against improper use.
 10. License requirements including inspection and renewal dates.
- C. Descriptions: Include the following:

1. Product name and model number. Use designations for products indicated on Contract Documents.
2. Manufacturer's name.
3. Equipment identification with serial number of each component.
4. Equipment function.
5. Operating characteristics.
6. Limiting conditions.
7. Performance curves.
8. Engineering data and tests.
9. Complete nomenclature and number of replacement parts.

D. Operating Procedures: Include the following, as applicable:

1. Startup procedures.
2. Equipment or system break-in procedures.
3. Routine and normal operating instructions.
4. Regulation and control procedures.
5. Instructions on stopping.
6. Normal shutdown instructions.
7. Seasonal and weekend operating instructions.
8. Required sequences for electric or electronic systems.
9. Special operating instructions and procedures.

E. Systems and Equipment Controls: Describe the sequence of operation, and diagram controls as installed.

F. Piped Systems: Diagram piping as installed, and identify color coding where required for identification.

1.10 SYSTEMS AND EQUIPMENT MAINTENANCE MANUALS

A. Systems and Equipment Maintenance Manuals: Assemble a complete set of data indicating maintenance of each system, subsystem, and piece of equipment not part of a system. Include manufacturers' maintenance documentation, preventive maintenance procedures and frequency, repair procedures, wiring and systems diagrams, lists of spare parts, and warranty information.

1. Engage a factory-authorized service representative to assemble and prepare information for each system, subsystem, and piece of equipment not part of a system.
2. Prepare a separate manual for each system and subsystem, in the form of an instructional manual for use by Owner's operating personnel.

B. Content: For each system, subsystem, and piece of equipment not part of a system, include source information, manufacturers' maintenance documentation, maintenance procedures, maintenance and service schedules, spare parts list and source information, maintenance service contracts, and warranties and bonds as described below.

- C. Source Information: List each system, subsystem, and piece of equipment included in manual, identified by product name and arranged to match manual's table of contents. For each product, list name, address, and telephone number of Installer or supplier and maintenance service agent, and cross-reference Specification Section number and title in Project Manual and drawing or schedule designation or identifier where applicable.
- D. Manufacturers' Maintenance Documentation: Include the following information for each component part or piece of equipment:
 - 1. Standard maintenance instructions and bulletins; include only sheets pertinent to product or component installed. Mark each sheet to identify each product or component incorporated into the Work. If data include more than one item in a tabular format, identify each item using appropriate references from the Contract Documents. Identify data applicable to the Work and delete references to information not applicable.
 - a. Prepare supplementary text if manufacturers' standard printed data are not available and where the information is necessary for proper operation and maintenance of equipment or systems.
 - 2. Drawings, diagrams, and instructions required for maintenance, including disassembly and component removal, replacement, and assembly.
 - 3. Identification and nomenclature of parts and components.
 - 4. List of items recommended to be stocked as spare parts.
- E. Maintenance Procedures: Include the following information and items that detail essential maintenance procedures:
 - 1. Test and inspection instructions.
 - 2. Troubleshooting guide.
 - 3. Precautions against improper maintenance.
 - 4. Disassembly; component removal, repair, and replacement; and reassembly instructions.
 - 5. Aligning, adjusting, and checking instructions.
 - 6. Demonstration and training video recording, if available.
- F. Maintenance and Service Schedules: Include service and lubrication requirements, list of required lubricants for equipment, and separate schedules for preventive and routine maintenance and service with standard time allotment.
 - 1. Scheduled Maintenance and Service: Tabulate actions for daily, weekly, monthly, quarterly, semiannual, and annual frequencies.
 - 2. Maintenance and Service Record: Include manufacturers' forms for recording maintenance.
- G. Spare Parts List and Source Information: Include lists of replacement and repair parts, with parts identified and cross-referenced to manufacturers' maintenance documentation and local sources of maintenance materials and related services.
- H. Maintenance Service Contracts: Include copies of maintenance agreements with name and telephone number of service agent.

- I. Warranties and Bonds: Include copies of warranties and bonds and lists of circumstances and conditions that would affect validity of warranties or bonds.
 - 1. Include procedures to follow and required notifications for warranty claims.
- J. Drawings: Prepare drawings supplementing manufacturers' printed data to illustrate the relationship of component parts of equipment and systems and to illustrate control sequence and flow diagrams. Coordinate these drawings with information contained in record Drawings to ensure correct illustration of completed installation.
 - 1. Do not use original project record documents as part of maintenance manuals.

1.11 PRODUCT MAINTENANCE MANUALS

- A. Product Maintenance Manual: Assemble a complete set of maintenance data indicating care and maintenance of each product, material, and finish incorporated into the Work.
- B. Content: Organize manual into a separate section for each product, material, and finish. Include source information, product information, maintenance procedures, repair materials and sources, and warranties and bonds, as described below.
- C. Source Information: List each product included in manual, identified by product name and arranged to match manual's table of contents. For each product, list name, address, and telephone number of Installer or supplier and maintenance service agent, and cross-reference Specification Section number and title in Project Manual and drawing or schedule designation or identifier where applicable.
- D. Product Information: Include the following, as applicable:
 - 1. Product name and model number.
 - 2. Manufacturer's name.
 - 3. Color, pattern, and texture.
 - 4. Material and chemical composition.
 - 5. Reordering information for specially manufactured products.
- E. Maintenance Procedures: Include manufacturer's written recommendations and the following:
 - 1. Inspection procedures.
 - 2. Types of cleaning agents to be used and methods of cleaning.
 - 3. List of cleaning agents and methods of cleaning detrimental to product.
 - 4. Schedule for routine cleaning and maintenance.
 - 5. Repair instructions.
- F. Repair Materials and Sources: Include lists of materials and local sources of materials and related services.
- G. Warranties and Bonds: Include copies of warranties and bonds and lists of circumstances and conditions that would affect validity of warranties or bonds.

1. Include procedures to follow and required notifications for warranty claims.

PART 2 - PRODUCTS (Not Used)

PART 3 - EXECUTION (Not Used)

END OF SECTION 017823

SECTION 017839 - PROJECT RECORD DOCUMENTS

PART 1 - GENERAL

1.1 RELATED DOCUMENTS

- A. Drawings and general provisions of the Contract, including General and Supplementary Conditions and other Division 01 Specification Sections, apply to this Section.

1.2 SUMMARY

- A. Section includes administrative and procedural requirements for project record documents, including the following:
 - 1. Record Drawings.
 - 2. Record Specifications.
 - 3. Record Product Data.
 - 4. Miscellaneous record submittals.
- B. Related Requirements:
 - 1. Division 01 Section "Closeout Procedures" for general closeout procedures.
 - 2. Division 01 Section "Operation and Maintenance Data" for operation and maintenance manual requirements.
 - 3. Divisions 02 through 33 Sections for specific requirements for project record documents of the Work in those Sections.

1.3 CLOSEOUT SUBMITTALS

- A. Record Drawings: Comply with the following:
 - 1. Number of Copies: Submit one set of marked-up record prints.
 - 2. Number of Copies: Submit copies of record Drawings as follows:
 - a. Initial Submittal:
 - 1) Submit PDF electronic files of scanned record prints and three of file prints.
 - 2) Architect will indicate whether general scope of changes, additional information recorded, and quality of drafting are acceptable.
 - b. Final Submittal:
 - 1) Submit PDF electronic files of scanned record prints and three sets of prints.

- 2) Print each drawing, whether or not changes and additional information were recorded.
- B. Record Specifications: Submit one paper copies and annotated PDF electronic files of Project's Specifications, including addenda and contract modifications.
 - C. Record Product Data: Submit one paper copy and annotated PDF electronic files of each submittal.
 1. Where record Product Data are required as part of operation and maintenance manuals, submit duplicate marked-up Product Data as a component of manual.
 - D. Miscellaneous Record Submittals: See other Specification Sections for miscellaneous record-keeping requirements and submittals in connection with various construction activities. Submit one paper and annotated PDF electronic files and directories of each submittal.
 - E. Reports: Submit written report weekly indicating items incorporated into project record documents concurrent with progress of the Work, including revisions, concealed conditions, field changes, product selections, and other notations incorporated.

PART 2 - PRODUCTS

2.1 RECORD DRAWINGS

- A. Record Prints: Maintain one set of marked-up paper copies of the Contract Drawings and Shop Drawings, incorporating new and revised drawings as modifications are issued.
 1. Preparation: Mark record prints to show the actual installation where installation varies from that shown originally. Require individual or entity who obtained record data, whether individual or entity is Installer, subcontractor, or similar entity, to provide information for preparation of corresponding marked-up record prints.
 - a. Give particular attention to information on concealed elements that would be difficult to identify or measure and record later.
 - b. Accurately record information in an acceptable drawing technique.
 - c. Record data as soon as possible after obtaining it.
 - d. Record and check the markup before enclosing concealed installations.
 - e. Cross-reference record prints to corresponding archive photographic documentation.
 2. Content: Types of items requiring marking include, but are not limited to, the following:
 - a. Dimensional changes to Drawings.
 - b. Revisions to details shown on Drawings.
 - c. Depths of foundations below first floor.

- d. Locations and depths of underground utilities.
 - e. Revisions to routing of piping and conduits.
 - f. Revisions to electrical circuitry.
 - g. Actual equipment locations.
 - h. Duct size and routing.
 - i. Locations of concealed internal utilities.
 - j. Changes made by Change Order or Construction Change Directive.
 - k. Changes made following Architect's written orders.
 - l. Details not on the original Contract Drawings.
 - m. Field records for variable and concealed conditions.
 - n. Record information on the Work that is shown only schematically.
3. Mark the Contract Drawings and Shop Drawings completely and accurately. Use personnel proficient at recording graphic information in production of marked-up record prints.
 4. Mark record sets with erasable, red-colored pencil. Use other colors to distinguish between changes for different categories of the Work at same location.
 5. Mark important additional information that was either shown schematically or omitted from original Drawings.
 6. Note Construction Change Directive numbers, alternate numbers, Change Order numbers, and similar identification, where applicable.
- B. Newly Prepared Record Drawings: Prepare new Drawings instead of preparing record Drawings where Architect determines that neither the original Contract Drawings nor Shop Drawings are suitable to show actual installation.
1. New Drawings may be required when a Change Order is issued as a result of accepting an alternate, substitution, or other modification.
 2. Consult Architect and Construction Manager for proper scale and scope of detailing and notations required to record the actual physical installation and its relation to other construction. Integrate newly prepared record Drawings into record Drawing sets; comply with procedures for formatting, organizing, copying, binding, and submitting.
- C. Format: Identify and date each record Drawing; include the designation "PROJECT RECORD DRAWING" in a prominent location.
1. Record Prints: Organize record prints and newly prepared record Drawings into manageable sets. Bind each set with durable paper cover sheets. Include identification on cover sheets.
 2. Format: Annotated PDF electronic file with comment function enabled.
 3. Record Digital Data Files: Organize digital data information into separate electronic files that correspond to each sheet of the Contract Drawings. Name each file with the sheet identification. Include identification in each digital data file.
 4. Identification: As follows:
 - a. Project name.
 - b. Date.
 - c. Designation "PROJECT RECORD DRAWINGS."

- d. Name of Architect and Construction Manager.
- e. Name of Contractor.

2.2 RECORD SPECIFICATIONS

- A. Preparation: Mark Specifications to indicate the actual product installation where installation varies from that indicated in Specifications, addenda, and contract modifications.
 1. Give particular attention to information on concealed products and installations that cannot be readily identified and recorded later.
 2. Mark copy with the proprietary name and model number of products, materials, and equipment furnished, including substitutions and product options selected.
 3. Record the name of manufacturer, supplier, Installer, and other information necessary to provide a record of selections made.
 4. For each principal product, indicate whether record Product Data has been submitted in operation and maintenance manuals instead of submitted as record Product Data.
 5. Note related Change Orders, record Product Data, and record Drawings where applicable.
- B. Format: Submit record Specifications as annotated PDF electronic file of marked-up paper copy of Specifications.

2.3 RECORD PRODUCT DATA

- A. Preparation: Mark Product Data to indicate the actual product installation where installation varies substantially from that indicated in Product Data submittal.
 1. Give particular attention to information on concealed products and installations that cannot be readily identified and recorded later.
 2. Include significant changes in the product delivered to Project site and changes in manufacturer's written instructions for installation.
 3. Note related Change Orders, record Specifications, and record Drawings where applicable.
- B. Format: Submit record Product Data as annotated PDF electronic file of marked-up paper copy of Product Data.
 1. Include record Product Data directory organized by Specification Section number and title, electronically linked to each item of record Product Data.

2.4 MISCELLANEOUS RECORD SUBMITTALS

- A. Assemble miscellaneous records required by other Specification Sections for miscellaneous record keeping and submittal in connection with actual performance of the Work. Bind or file miscellaneous records and identify each, ready for continued use and reference.

- B. Format: Submit miscellaneous record submittals as PDF electronic file of marked-up miscellaneous record submittals.
 - 1. Include miscellaneous record submittals directory organized by Specification Section number and title, electronically linked to each item of miscellaneous record submittals.

PART 3 - EXECUTION

3.1 RECORDING AND MAINTENANCE

- A. Recording: Maintain one copy of each submittal during the construction period for project record document purposes. Post changes and revisions to project record documents as they occur; do not wait until end of Project.
- B. Maintenance of Record Documents and Samples: Store record documents and Samples in the field office apart from the Contract Documents used for construction. Does not use project record documents for construction purposes. Maintain record documents in good order and in a clean, dry, legible condition, protected from deterioration and loss. Provide access to project record documents for Architect's and Construction Manager's reference during normal working hours.

END OF SECTION 017839

SECTION 017900 - DEMONSTRATION AND TRAINING

PART 1 - GENERAL

1.1 RELATED DOCUMENTS

- A. Drawings and general provisions of the Contract, including General and Supplementary Conditions and other Division 01 Specification Sections, apply to this Section.

1.2 SUMMARY

- A. Section includes administrative and procedural requirements for instructing Owner's personnel, including the following:
 - 1. Instruction in operation and maintenance of systems, subsystems, and equipment including equipment furnished by Owner.
 - 2. Demonstration and training video recordings.

1.3 INFORMATIONAL SUBMITTALS

- A. Instruction Program: Submit outline of instructional program for demonstration and training, including a list of training modules and a schedule of proposed dates, times, length of instruction time, and instructors' names for each training module. Include learning objective and outline for each training module.
 - 1. Indicate proposed training modules using manufacturer-produced demonstration and training video recordings for systems, equipment, and products in lieu of video recording of live instructional module.
- B. Qualification Data: For facilitator, instructor, and videographer.
- C. Attendance Record: For each training module, submit list of participants and length of instruction time.
- D. Evaluations: For each participant and for each training module, submit results and documentation of performance-based test.

1.4 CLOSEOUT SUBMITTALS

- A. Demonstration and Training Video Recordings: Submit two copies within seven days of end of each training module.
 - 1. Identification: On each copy, provide an applied label with the following information:

- a. Name of Project.
 - b. Name and address of videographer.
 - c. Name of Architect.
 - d. Name of Construction Manager.
 - e. Name of Contractor.
 - f. Date of video recording.
2. Transcript: Prepared and bound in format matching operation and maintenance manuals. Mark appropriate identification on front and spine of each binder. Include a cover sheet with same label information as the corresponding video recording. Include name of Project and date of video recording on each page.
 3. Transcript: Prepared in PDF electronic format. Include a cover sheet with same label information as the corresponding video recording and a table of contents with links to corresponding training components. Include name of Project and date of video recording on each page.
 4. At completion of training, submit complete training manual(s) for Owner's use prepared in same paper and PDF file format required for operation and maintenance manuals specified in Section 017823 "Operation and Maintenance Data."

1.5 QUALITY ASSURANCE

- A. Facilitator Qualifications: A firm or individual experienced in training or educating maintenance personnel in a training program similar in content and extent to that indicated for this Project, and whose work has resulted in training or education with a record of successful learning performance.
- B. Instructor Qualifications: A factory-authorized service representative, complying with requirements in Section 014000 "Quality Requirements," experienced in operation and maintenance procedures and training.
- C. Videographer Qualifications: A professional videographer who is experienced photographing demonstration and training events similar to those required.
- D. Preinstruction Conference: Conduct conference at Project site to comply with requirements in Section 013100 "Project Management and Coordination." Review methods and procedures related to demonstration and training including, but not limited to, the following:
 1. Inspect and discuss locations and other facilities required for instruction.
 2. Review and finalize instruction schedule and verify availability of educational materials, instructors' personnel, audiovisual equipment, and facilities needed to avoid delays.
 3. Review required content of instruction.
 4. For instruction that must occur outside, review weather and forecasted weather conditions and procedures to follow if conditions are unfavorable.

1.6 COORDINATION

- A. Coordinate instruction schedule with Owner's operations. Adjust schedule as required to minimize disrupting Owner's operations and to ensure availability of Owner's personnel.
- B. Coordinate instructors, including providing notification of dates, times, length of instruction time, and course content.
- C. Coordinate content of training modules with content of approved emergency, operation, and maintenance manuals. Do not submit instruction program until operation and maintenance data have been reviewed and approved by Owner.

1.7 INSTRUCTION PROGRAM

- A. Program Structure: Develop an instruction program that includes individual training modules for each system and for equipment not part of a system, as required by individual Specification Sections.
- B. Training Modules: Develop a learning objective and teaching outline for each module. Include a description of specific skills and knowledge that participant is expected to master. For each module, include instruction for the following as applicable to the system, equipment, or component:
 - 1. Basis of System Design, Operational Requirements, and Criteria: Include the following:
 - a. System, subsystem, and equipment descriptions.
 - b. Performance and design criteria if Contractor is delegated design responsibility.
 - c. Operating standards.
 - d. Regulatory requirements.
 - e. Equipment function.
 - f. Operating characteristics.
 - g. Limiting conditions.
 - h. Performance curves.
 - 2. Documentation: Review the following items in detail:
 - a. Emergency manuals.
 - b. Systems and equipment operation manuals.
 - c. Systems and equipment maintenance manuals.
 - d. Product maintenance manuals.
 - e. Project Record Documents.
 - f. Identification systems.
 - g. Warranties and bonds.
 - h. Maintenance service agreements and similar continuing commitments.
 - 3. Emergencies: Include the following, as applicable:

- a. Instructions on meaning of warnings, trouble indications, and error messages.
 - b. Instructions on stopping.
 - c. Shutdown instructions for each type of emergency.
 - d. Operating instructions for conditions outside of normal operating limits.
 - e. Sequences for electric or electronic systems.
 - f. Special operating instructions and procedures.
4. Operations: Include the following, as applicable:
- a. Startup procedures.
 - b. Equipment or system break-in procedures.
 - c. Routine and normal operating instructions.
 - d. Regulation and control procedures.
 - e. Control sequences.
 - f. Safety procedures.
 - g. Instructions on stopping.
 - h. Normal shutdown instructions.
 - i. Operating procedures for emergencies.
 - j. Operating procedures for system, subsystem, or equipment failure.
 - k. Seasonal and weekend operating instructions.
 - l. Required sequences for electric or electronic systems.
 - m. Special operating instructions and procedures.
5. Adjustments: Include the following:
- a. Alignments.
 - b. Checking adjustments.
 - c. Noise and vibration adjustments.
 - d. Economy and efficiency adjustments.
6. Troubleshooting: Include the following:
- a. Diagnostic instructions.
 - b. Test and inspection procedures.
7. Maintenance: Include the following:
- a. Inspection procedures.
 - b. Types of cleaning agents to be used and methods of cleaning.
 - c. List of cleaning agents and methods of cleaning detrimental to product.
 - d. Procedures for routine cleaning.
 - e. Procedures for preventive maintenance.
 - f. Procedures for routine maintenance.
 - g. Instruction on use of special tools.
8. Repairs: Include the following:
- a. Diagnosis instructions.
 - b. Repair instructions.

- c. Disassembly; component removal, repair, and replacement; and reassembly instructions.
- d. Instructions for identifying parts and components.
- e. Review of spare parts needed for operation and maintenance.

1.8 PREPARATION

- A. Assemble educational materials necessary for instruction, including documentation and training module. Assemble training modules into a training manual organized in coordination with requirements in Section 017823 "Operation and Maintenance Data."
- B. Set up instructional equipment at instruction location.

1.9 INSTRUCTION

- A. Facilitator: Engage a qualified facilitator to prepare instruction program and training modules, to coordinate instructors, and to coordinate between Contractor and Owner for number of participants, instruction times, and location.
- B. Engage qualified instructors to instruct Owner's personnel to adjust, operate, and maintain systems, subsystems, and equipment not part of a system.
 - 1. Architect will furnish an instructor to describe basis of system design, operational requirements, criteria, and regulatory requirements.
 - 2. Owner will furnish an instructor to describe Owner's operational philosophy.
 - 3. Owner will furnish Contractor with names and positions of participants.
- C. Scheduling: Provide instruction at mutually agreed-on times. For equipment that requires seasonal operation, provide similar instruction at start of each season.
 - 1. Schedule training with Owner with at least seven days' advance notice.
- D. Training Location and Reference Material: Conduct training on-site in the completed and fully operational facility using the actual equipment in-place. Conduct training using final operation and maintenance data submittals.
- E. Evaluation: At conclusion of each training module, assess and document each participant's mastery of module by use of a written performance-based test.
- F. Cleanup: Collect used and leftover educational materials and give to Owner. Remove instructional equipment. Restore systems and equipment to condition existing before initial training use.

1.10 DEMONSTRATION AND TRAINING VIDEO RECORDINGS

- A. General: Engage a qualified commercial videographer to record demonstration and training video recordings. Record each training module separately. Include classroom

instructions and demonstrations, board diagrams, and other visual aids, but not student practice.

1. At beginning of each training module, record each chart containing learning objective and lesson outline.
- B. Digital Video Recordings: Provide high-resolution, digital video in MPEG format, produced by a digital camera with minimum sensor resolution of 12 megapixels and capable of recording in full HD mode with vibration reduction technology.
1. Submit video recordings on CD-ROM or thumb drive and by uploading to web-based Project software site.
 2. File Hierarchy: Organize folder structure and file locations according to Project Manual table of contents. Provide complete screen-based menu.
 3. File Names: Utilize file names based on name of equipment generally described in video segment, as identified in Project specifications.
 4. Contractor and Installer Contact File: Using appropriate software, create a file for inclusion on the equipment demonstration and training recording that describes the following for each Contractor involved on the Project, arranged according to Project Manual table of contents:
 - a. Name of Contractor/Installer.
 - b. Business address.
 - c. Business phone number.
 - d. Point of contact.
 - e. Email address.
- C. Recording: Mount camera on tripod before starting recording, unless otherwise necessary to adequately cover area of demonstration and training. Display continuous running time.
1. Film training session(s) in segments not to exceed 15 minutes.
 - a. Produce segments to present a single significant piece of equipment per segment.
 - b. Organize segments with multiple pieces of equipment to follow order of Project Manual table of contents.
 - c. Where a training session on a particular piece of equipment exceeds 15 minutes, stop filming and pause training session. Begin training session again upon commencement of new filming segment.
- D. Light Levels: Verify light levels are adequate to properly light equipment. Verify equipment markings are clearly visible prior to recording.
1. Furnish additional portable lighting as required.
- E. Narration: Describe scenes on video recording by audio narration by microphone while or dubbing audio narration off-site after video recording is recorded. Include description of items being viewed.

- F. Transcript: Provide a transcript of the narration. Display images and running time captured from videotape opposite the corresponding narration segment.
- G. Preproduced Video Recordings: Provide video recordings used as a component of training modules in same format as recordings of live training.

PART 2 - PRODUCTS

PART 3 - EXECUTION

END OF SECTION 017900

SECTION 024119 - SELECTIVE STRUCTURE DEMOLITION

PART 1 - GENERAL

1.1 RELATED DOCUMENTS

- A. Drawings and general provisions of the Contract, including General and Supplementary Conditions and Division 01 Specification Sections, apply to this Section.

1.2 SUMMARY

- A. Section Includes:
 - 1. Demolition and removal of selected portions of building elements.
 - 2. Salvage of existing items to be reused or recycled.
- B. Related Requirements:
 - 1. Division 01 Section "Summary" for restrictions on the use of the premises, Owner-occupancy requirements, and phasing requirements.
 - 2. Division 01 Section "Execution" for cutting and patching procedures.

1.3 DEFINITIONS

- A. Remove: Detach items from existing construction and legally dispose of them off-site unless indicated to be removed and salvaged or removed and reinstalled.
- B. Remove and Reinstall: Detach items from existing construction, prepare for reuse, and reinstall where indicated.
- C. Existing to Remain: Existing items of construction that are not to be permanently removed and that are not otherwise indicated to be removed, removed and salvaged, or removed and reinstalled.

1.4 MATERIALS OWNERSHIP

- A. Unless otherwise indicated, demolition waste becomes property of Contractor.
- B. Historic items, relics, antiques, and similar objects including, but not limited to, cornerstones and their contents, commemorative plaques and tablets, and other items of interest or value to Owner that may be uncovered during demolition remain the property of Owner.
 - 1. Carefully salvage in a manner to prevent damage and promptly return to Owner.

1.5 PREINSTALLATION MEETINGS

- A. Predemolition Conference: Conduct conference at Project site.
 - 1. Inspect and discuss condition of construction to be selectively demolished.
 - 2. Review structural load limitations of existing structure.
 - 3. Review and finalize selective demolition schedule and verify availability of materials, demolition personnel, equipment, and facilities needed to make progress and avoid delays.
 - 4. Review requirements of work performed by other trades that rely on substrates exposed by selective demolition operations.
 - 5. Review areas where existing construction is to remain and requires protection.

1.6 INFORMATIONAL SUBMITTALS

- A. Qualification Data: For refrigerant recovery technician.
- B. Proposed Protection Measures: Submit report, including drawings, that indicates the measures proposed for protecting individuals and property, for environmental protection, for dust control and, for noise control. Indicate proposed locations and construction of barriers.
- C. Schedule of Selective Demolition Activities: Indicate the following:
 - 1. Detailed sequence of selective demolition and removal work, with starting and ending dates for each activity. Ensure Owner's on-site operations are uninterrupted.
 - 2. Interruption of utility services. Indicate how long utility services will be interrupted.
 - 3. Coordination for shutoff, capping, and continuation of utility services.
 - 4. Use of elevator and stairs.
 - 5. Coordination of Owner's continuing occupancy of portions of existing building and of Owner's partial occupancy of completed Work.
- D. Inventory: Submit a list of items to be removed and salvaged and deliver to Owner prior to start of demolition.
- E. Predemolition Photographs or Video: Submit before Work begins.
- F. Statement of Refrigerant Recovery: Signed by refrigerant recovery technician responsible for recovering refrigerant, stating that all refrigerant that was present was recovered and that recovery was performed according to EPA regulations. Include name and address of technician and date refrigerant was recovered.
- G. Warranties: Documentation indicated that existing warranties are still in effect after completion of selective demolition.

1.7 CLOSEOUT SUBMITTALS

- A. Inventory: Submit a list of items that have been removed and salvaged.
- B. Landfill Records: Indicate receipt and acceptance of hazardous wastes by a landfill facility licensed to accept hazardous wastes.

1.8 QUALITY ASSURANCE

- A. Refrigerant Recovery Technician Qualifications: Certified by an EPA-approved certification program.

1.9 FIELD CONDITIONS

- A. Owner will occupy portions of building immediately adjacent to selective demolition area. Conduct selective demolition so Owner's operations will not be disrupted.
- B. Conditions existing at time of inspection for bidding purpose will be maintained by Owner as far as practical.
 - 1. Before selective demolition, Owner will remove items as required:
- C. Notify Architect of discrepancies between existing conditions and Drawings before proceeding with selective demolition.
- D. Hazardous Materials: It is not expected that hazardous materials will be encountered in the Work.
 - 1. Hazardous materials will be removed by Owner before start of the Work.
 - 2. If suspected hazardous materials are encountered, do not disturb; immediately notify Architect and Owner. Hazardous materials will be removed by Owner under a separate contract.
- E. Storage or sale of removed items or materials on-site is not permitted.
- F. Utility Service: Maintain existing utilities indicated to remain in service and protect them against damage during selective demolition operations.
 - 1. Maintain fire-protection facilities in service during selective demolition operations.

PART 2 - PRODUCTS

2.1 PERFORMANCE REQUIREMENTS

- A. Regulatory Requirements: Comply with governing EPA notification regulations before beginning selective demolition. Comply with hauling and disposal regulations of authorities having jurisdiction.

- B. Standards: Comply with ANSI/ASSE A10.6 and NFPA 241.

PART 3 - EXECUTION

3.1 EXAMINATION

- A. Verify that utilities have been disconnected and capped before starting selective demolition operations.
- B. Review record documents of existing construction provided by Owner. Owner does not guarantee that existing conditions are same as those indicated in record documents.
- C. Survey existing conditions and correlate with requirements indicated to determine extent of selective demolition required.
- D. When unanticipated mechanical, electrical, or structural elements that conflict with intended function or design are encountered, investigate and measure the nature and extent of conflict. Promptly submit a written report to Architect.
- E. Perform an engineering survey of condition of building to determine whether removing any element might result in structural deficiency or unplanned collapse of any portion of structure or adjacent structures during selective building demolition operations.
1. Perform surveys as the Work progresses to detect hazards resulting from selective demolition activities.
 2. Steel Tendons: Locate tensioned steel tendons and include recommendations for de-tensioning.
- F. Survey of Existing Conditions: Record existing conditions by use of measured drawings and preconstruction photographs.
1. Inventory and record the condition of items to be removed and salvaged. Provide photographs of conditions that might be misconstrued as damage caused by salvage operations.
 2. Before selective demolition or removal of existing building elements that will be reproduced or duplicated in final Work, make permanent record of measurements, materials, and construction details required to make exact reproduction.

3.2 UTILITY SERVICES AND MECHANICAL/ELECTRICAL SYSTEMS

- A. Existing Services/Systems to Remain: Maintain services/systems indicated to remain and protect them against damage.
1. Comply with requirements for existing services/systems interruptions specified in Division 01 Section "Summary."

- B. Existing Services/Systems to Be Removed, Relocated, or Abandoned: Locate, identify, disconnect, and seal or cap off indicated utility services and mechanical/electrical systems serving areas to be selectively demolished.
1. Owner will arrange to shut off indicated services/systems when requested by Contractor.
 2. Arrange to shut off indicated utilities with utility companies.
 3. If services/systems are required to be removed, relocated, or abandoned, provide temporary services/systems that bypass area of selective demolition and that maintain continuity of services/systems to other parts of building.
 4. Disconnect, demolish, and remove fire-suppression systems, plumbing, and HVAC systems, equipment, and components indicated to be removed.
 - a. Piping to Be Removed: Remove portion of piping indicated to be removed and cap or plug remaining piping with same or compatible piping material.
 - b. Piping to Be Abandoned in Place: Drain piping and cap or plug piping with same or compatible piping material.
 - c. Equipment to Be Removed: Disconnect and cap services and remove equipment.
 - d. Equipment to Be Removed and Reinstalled: Disconnect and cap services and remove, clean, and store equipment; when appropriate, reinstall, reconnect, and make equipment operational.
 - e. Equipment to Be Removed and Salvaged: Disconnect and cap services and remove equipment and deliver to Owner.
 - f. Ducts to Be Removed: Remove portion of ducts indicated to be removed and plug remaining ducts with same or compatible ductwork material.
 - g. Ducts to Be Abandoned in Place: Cap or plug ducts with same or compatible ductwork material.
- C. Refrigerant: Remove refrigerant from mechanical equipment to be selectively demolished according to 40 CFR 82 and regulations of authorities having jurisdiction.

3.3 PREPARATION

- A. Site Access and Temporary Controls: Conduct selective demolition and debris-removal operations to ensure minimum interference with roads, streets, walks, walkways, and other adjacent occupied and used facilities.
1. Comply with requirements for access and protection specified in Division 01 Section "Temporary Facilities and Controls."
- B. Temporary Facilities: Provide temporary barricades and other protection required to prevent injury to people and damage to adjacent buildings and facilities to remain.
1. Provide protection to ensure safe passage of people around selective demolition area and to and from occupied portions of building.
 2. Provide temporary weather protection, during interval between selective demolition of existing construction on exterior surfaces and new construction, to prevent water leakage and damage to structure and interior areas.

3. Protect walls, ceilings, floors, and other existing finish work that are to remain or that are exposed during selective demolition operations.
 4. Cover and protect furniture, furnishings, and equipment that have not been removed.
 5. Comply with requirements for temporary enclosures, dust control, heating, and cooling specified in Division 01 Section "Temporary Facilities and Controls."
- C. Temporary Shoring: Provide and maintain shoring, bracing, and structural supports as required to preserve stability and prevent movement, settlement, or collapse of construction and finishes to remain, and to prevent unexpected or uncontrolled movement or collapse of construction being demolished.
1. Strengthen or add new supports when required during progress of selective demolition.

3.4 SELECTIVE DEMOLITION, GENERAL

- A. General: Demolish and remove existing construction only to the extent required by new construction and as indicated. Use methods required to complete the Work within limitations of governing regulations and as follows:
1. Proceed with selective demolition systematically, from higher to lower level. Complete selective demolition operations above each floor or tier before disturbing supporting members on the next lower level.
 2. Neatly cut openings and holes plumb, square, and true to dimensions required. Use cutting methods least likely to damage construction to remain or adjoining construction. Use hand tools or small power tools designed for sawing or grinding, not hammering and chopping, to minimize disturbance of adjacent surfaces. Temporarily cover openings to remain.
 3. Cut or drill from the exposed or finished side into concealed surfaces to avoid marring existing finished surfaces.
 4. Do not use cutting torches until work area is cleared of flammable materials. At concealed spaces, such as duct and pipe interiors, verify condition and contents of hidden space before starting flame-cutting operations. Maintain fire watch and portable fire-suppression devices during flame-cutting operations.
 5. Maintain adequate ventilation when using cutting torches.
 6. Remove decayed, vermin-infested, or otherwise dangerous or unsuitable materials and promptly dispose of off-site.
 7. Remove structural framing members and lower to ground by method suitable to avoid free fall and to prevent ground impact or dust generation.
 8. Locate selective demolition equipment and remove debris and materials so as not to impose excessive loads on supporting walls, floors, or framing.
 9. Dispose of demolished items and materials promptly. Comply with requirements in Division 01 Section "Construction Waste Management and Disposal."
- B. Reuse of Building Elements: Project has been designed to result in end-of-Project rates for reuse of building elements as follows. Do not demolish building elements beyond what is indicated on Drawings without Architect's approval.

1. Building Structure and Shell: Maintain 95 percent of existing walls, floors, and roof. Maintain existing building structure (including structural floor and roof decking) and envelope (exterior skin and framing, excluding window assemblies and nonstructural roofing material) not indicated to be demolished; do not demolish such existing construction beyond indicated limits.
2. Nonshell Elements: Maintain existing interior nonstructural elements (interior walls, doors, floor coverings, and ceiling systems) not indicated to be demolished; do not demolish such existing construction beyond indicated limits.

C. Removed and Salvaged Items:

1. Clean salvaged items.
2. Pack or crate items after cleaning. Identify contents of containers.
3. Store items in a secure area until delivery to Owner.
4. Transport items to Owner's storage area on-site designated by Owner.
5. Protect items from damage during transport and storage.

D. Removed and Reinstalled Items:

1. Clean and repair items to functional condition adequate for intended reuse.
2. Pack or crate items after cleaning and repairing. Identify contents of containers.
3. Protect items from damage during transport and storage.
4. Reinstall items in locations indicated. Comply with installation requirements for new materials and equipment. Provide connections, supports, and miscellaneous materials necessary to make item functional for use indicated.

- E. Existing Items to Remain: Protect construction indicated to remain against damage and soiling during selective demolition. When permitted by Architect, items may be removed to a suitable, protected storage location during selective demolition and cleaned and reinstalled in their original locations after selective demolition operations are complete.

3.5 SELECTIVE DEMOLITION PROCEDURES FOR SPECIFIC MATERIALS

- A. Concrete: Demolish in small sections. Using power-driven saw, cut concrete to a depth of at least 3/4 inch at junctures with construction to remain. Dislodge concrete from reinforcement at perimeter of areas being demolished, cut reinforcement, and then remove remainder of concrete. Neatly trim openings to dimensions indicated.
- B. Concrete: Demolish in sections. Cut concrete full depth at junctures with construction to remain and at regular intervals using power-driven saw, then remove concrete between saw cuts.
- C. Masonry: Demolish in small sections. Cut masonry at junctures with construction to remain, using power-driven saw, then remove masonry between saw cuts.
- D. Concrete Slabs-on-Grade: Saw-cut perimeter of area to be demolished, then break up and remove.

- E. Resilient Floor Coverings: Remove floor coverings and adhesive according to recommendations in RFCI's "Recommended Work Practices for the Removal of Resilient Floor Coverings." Do not use methods requiring solvent-based adhesive strippers.

3.6 DISPOSAL OF DEMOLISHED MATERIALS

- A. General: Except for items or materials indicated to be reused, salvaged, reinstalled, or otherwise indicated to remain Owner's property, remove demolished materials from Project site and legally dispose of them in an EPA-approved landfill.
 - 1. Do not allow demolished materials to accumulate on-site.
 - 2. Remove and transport debris in a manner that will prevent spillage on adjacent surfaces and areas.
 - 3. Remove debris from elevated portions of building by chute, hoist, or other device that will convey debris to grade level in a controlled descent.
 - 4. Comply with requirements specified in Division 01 Section "Construction Waste Management and Disposal."
- B. Burning: Do not burn demolished materials.
- C. Disposal: Transport demolished materials off Owner's property and legally dispose of them.

3.7 CLEANING

- A. Clean adjacent structures and improvements of dust, dirt, and debris caused by selective demolition operations. Return adjacent areas to condition existing before selective demolition operations began.

3.8 SELECTIVE DEMOLITION

- A. As indicated on the drawings.

END OF SECTION 024119

SECTION 042000 - UNIT MASONRY

PART 1 - GENERAL

1.1 RELATED DOCUMENTS

- A. Drawings and general provisions of the Contract, including General and Supplementary Conditions and Division 01 Specification Sections, apply to this Section.

1.2 SUMMARY

- A. Section Includes:
 - 1. Concrete masonry units.

1.3 DEFINITIONS

- A. CMU(s): Concrete masonry unit(s).
- B. Reinforced Masonry: Masonry containing reinforcing steel in grouted cells.

1.4 PERFORMANCE REQUIREMENTS

- A. Provide structural unit masonry that develops indicated net-area compressive strengths at 28 days.
 - 1. Determine net-area compressive strength of masonry from average net-area compressive strengths of masonry units and mortar types (unit-strength method) according to Tables 1 and 2 in ACI 530.1/ASCE 6/TMS 602.
 - 2. Determine net-area compressive strength of masonry by testing masonry prisms according to ASTM C 1314.

1.5 PRECONSTRUCTION TESTING

- A. Preconstruction Testing Service: Owner will engage a qualified independent testing agency to perform preconstruction testing indicated below. Retesting of materials that fail to comply with specified requirements shall be done at Contractor's expense.
 - 1. Clay Masonry Unit Test: For each type of unit required, according to ASTM C 67 for compressive strength.
 - 2. Concrete Masonry Unit Test: For each type of unit required, according to ASTM C 140 for compressive strength.

3. Mortar Test (Property Specification): For each mix required, according to ASTM C 109/C 109M for compressive strength, ASTM C 1506 for water retention, and ASTM C 91 for air content.
4. Mortar Test (Property Specification): For each mix required, according to ASTM C 780 for compressive strength.
5. Grout Test (Compressive Strength): For each mix required, according to ASTM C 1019.
6. Prism Test: For each type of construction required, according to ASTM C 1314.

1.6 ACTION SUBMITTALS

A. Product Data: For each type of product indicated.

1. Masonry Units: Show sizes, profiles, coursing, and locations of special shapes.
2. Reinforcing Steel: Detail bending and placement of unit masonry reinforcing bars. Comply with ACI 315, "Details and Detailing of Concrete Reinforcement." See elevations of reinforced walls.
3. Fabricated Flashing: Detail corner units, end-dam units, and other special applications.

B. LEED Submittals:

1. Product Certificates for Credit MR 5: For products and materials required to comply with requirements for regional materials indicating location and distance from Project of material manufacturer and point of extraction, harvest, or recovery for each raw material. Include statement indicating cost for each regional material and the fraction by weight that is considered regional.

C. Shop Drawings: For the following:

1. Masonry Units: Show sizes, profiles, coursing, and locations of special shapes.
2. Reinforcing Steel: Detail bending and placement of unit masonry reinforcing bars. Comply with ACI 315, "Details and Detailing of Concrete Reinforcement." Show elevations of reinforced walls.
3. Fabricated Flashing: Detail corner units, end-dam units, and other special applications

D. Samples for Initial Selection:

1. CMUs to be painted.

E. Samples for Verification: For each type and color of the following:

1. Exposed CMUs.

1.7 INFORMATIONAL SUBMITTALS

- ### A. List of Materials Used in Constructing Mockups: List generic product names together with manufacturers, manufacturers' product names, model numbers, lot numbers,

batch numbers, source of supply, and other information as required to identify materials used. Include mix proportions for mortar and grout and source of aggregates.

1. Submittal is for information only. Neither receipt of list nor approval of mockup constitutes approval of deviations from the Contract Documents unless such deviations are specifically brought to the attention of Architect and approved in writing.
- B. Qualification Data: For testing agency.
- C. Material Certificates: For each type and size of the following:
 1. Masonry units.
 - a. Include data on material properties & material test reports substantiating compliance with requirements.
 2. Cementitious materials. Include brand, type, and name of manufacturer.
 3. Preblended, dry mortar mixes. Include description of type and proportions of ingredients.
 4. Reinforcing bars.
 5. Joint reinforcement.
 6. Anchors, ties, and metal accessories.
- D. Mix Designs: For each type of mortar. Include description of type and proportions of ingredients.
 1. Include test reports for mortar mixes required to comply with property specification. Test according to ASTM C 109/C 109M for compressive strength, ASTM C 1506 for water retention, and ASTM C 91 for air content.
 2. Include test reports, according to ASTM C 1019, for grout mixes required to comply with compressive strength requirement.
- E. Statement of Compressive Strength of Masonry: For each combination of masonry unit type and mortar type, provide statement of average net-area compressive strength of masonry units, mortar type, and resulting net-area compressive strength of masonry determined according to Tables 1 and 2 in ACI 530.1/ASCE 6/TMS 602.
- F. Cold-Weather and Hot-Weather Procedures: Detailed description of methods, materials, and equipment to be used to comply with requirements.

1.8 QUALITY ASSURANCE

- A. Testing Agency Qualifications: Qualified according to ASTM C 1093 for testing indicated.
- B. Source Limitations for Masonry Units: Obtain exposed masonry units of a uniform texture and color, or a uniform blend within the ranges accepted for these characteristics, from single source from single manufacturer for each product required.

- C. Source Limitations for Mortar Materials: Obtain mortar ingredients of a uniform quality, including color for exposed masonry, from single manufacturer for each cementitious component and from single source or producer for each aggregate.
- D. Masonry Standard: Comply with ACI 530.1/ASCE 6/TMS 602 unless modified by requirements in the Contract Documents.
- E. Preinstallation Conference: Conduct conference at Project site to comply with requirements in Division 01 Section "Project Management and Coordination."

1.9 DELIVERY, STORAGE, AND HANDLING

- A. Store masonry units on elevated platforms in a dry location. If units are not stored in an enclosed location, cover tops and sides of stacks with waterproof sheeting, securely tied. If units become wet, do not install until they are dry.
- B. Store cementitious materials on elevated platforms, under cover, and in a dry location. Do not use cementitious materials that have become damp.
- C. Store aggregates where grading and other required characteristics can be maintained and contamination avoided.
- D. Deliver preblended, dry mortar mix in moisture-resistant containers designed for use with dispensing silos. Store preblended, dry mortar mix in delivery containers on elevated platforms, under cover, and in a dry location or in covered weatherproof dispensing silos.
- E. Store masonry accessories, including metal items, to prevent corrosion and accumulation of dirt and oil.

1.10 PROJECT CONDITIONS

- A. Protection of Masonry: During construction, cover tops of walls, projections, and sills with waterproof sheeting at end of each day's work. Cover partially completed masonry when construction is not in progress.
 - 1. Extend cover a minimum of 24 inches down both sides of walls and hold cover securely in place.
 - 2. Where one wythe of multiwythe masonry walls is completed in advance of other wythes, secure cover a minimum of down face next to unconstructed wythe and hold cover in place.
- B. Do not apply uniform floor or roof loads for at least 12 hours and concentrated loads for at least three days after building masonry walls or columns.
- C. Stain Prevention: Prevent grout, mortar, and soil from staining the face of masonry to be left exposed or painted. Immediately remove grout, mortar, and soil that come in contact with such masonry.

1. Protect base of walls from rain-splashed mud and from mortar splatter by spreading coverings on ground and over wall surface.
 2. Protect sills, ledges, and projections from mortar droppings.
 3. Protect surfaces of window and door frames, as well as similar products with painted and integral finishes, from mortar droppings.
 4. Turn scaffold boards near the wall on edge at the end of each day to prevent rain from splashing mortar and dirt onto completed masonry.
- D. Cold-Weather Requirements: Do not use frozen materials or materials mixed or coated with ice or frost. Do not build on frozen substrates. Remove and replace unit masonry damaged by frost or by freezing conditions. Comply with cold-weather construction requirements contained in ACI 530.1/ASCE 6/TMS 602.
1. Cold-Weather Cleaning: Use liquid cleaning methods only when air temperature is 40 deg F and higher and will remain so until masonry has dried, but not less than seven days after completing cleaning.
- E. Hot-Weather Requirements: Comply with hot-weather construction requirements contained in ACI 530.1/ASCE 6/TMS 602.

PART 2 - PRODUCTS

2.1 MASONRY UNITS, GENERAL

- A. Defective Units: Referenced masonry unit standards may allow a certain percentage of units to contain chips, cracks, or other defects exceeding limits stated in the standard. Do not use units where such defects will be exposed in the completed Work.
- B. Fire-Resistance Ratings: Where indicated, provide units that comply with requirements for fire-resistance ratings indicated as determined by testing according to ASTM E 119, by equivalent masonry thickness, or by other means, as acceptable to authorities having jurisdiction.

2.2 CONCRETE MASONRY UNITS

- A. Regional Materials: CMUs shall be manufactured within 500 miles of Project site from aggregates and cement that have been extracted, harvested, or recovered, as well as manufactured, within 500 miles of Project site.
- B. Shapes: Provide shapes indicated and as follows, with exposed surfaces matching exposed faces of adjacent units unless otherwise indicated.
 1. Provide special shapes for lintels, corners, jambs, sashes, movement joints, headers, bonding, and other special conditions.
 2. Provide square-edged units for outside corners unless otherwise indicated.

C. CMUs: ASTM C 90.

1. Unit Compressive Strength: Provide units with minimum average net-area compressive strength of 2800 psi
2. Density Classification: Normal weight unless otherwise indicated.
3. Size (Width): Manufactured to dimensions 3/8 inch less than nominal dimensions.
4. Size (Width): Manufactured to the following dimensions:
 - a. nominal.
5. Exposed Faces: Provide color and texture matching the range represented by Architect's sample.

2.3 MASONRY LINTELS

- A. General: Provide one of the following:
- B. Masonry Lintels: Prefabricated or built-in-place masonry lintels made from bond beam CMUs with reinforcing bars placed as indicated and filled with coarse grout. Cure precast lintels before handling and installing. Temporarily support built-in-place lintels until cured.
- C. Regional Materials: Aggregate for mortar and grout, cement, and lime] shall be extracted, harvested, or recovered, as well as manufactured, within 500 miles of Project site.
- D. Portland Cement: ASTM C 150, Type I or II, except Type III may be used for cold-weather construction. Provide natural color or white cement as required to produce mortar color indicated.
- E. Hydrated Lime: ASTM C 207, Type S.
- F. Portland Cement-Lime Mix: Packaged blend of portland cement and hydrated lime containing no other ingredients.
- G. Masonry Cement: ASTM C 91.
 1. Products: Subject to compliance with requirements, available products that may be incorporated into the Work include, but are not limited to, the following:
 - a. Capital Materials Corporation; Flamingo Color Masonry Cement.
 - b. Lehigh Cement Company; Lehigh Masonry Cement.
 - c. National Cement Company, Inc.; Coosa Masonry Cement.

2.4 MASONRY JOINT REINFORCEMENT

- A. General: Install entire length of longitudinal side rods in mortar with a minimum cover of 5/8 inch on exterior side of walls, 1/2 inch elsewhere. Lap reinforcement a minimum of 6 inches.
- B. Security walls: #5 bars at 8 inches o.c. in filled cells.
- C. Non-secure walls: #5 bars at 48" o.k.
 - 3. Provide reinforcement not more than 8 inches above and below wall openings and extending 12 inches beyond openings in addition to continuous reinforcement.
- D. Interrupt joint reinforcement at control and expansion joints unless otherwise indicated.
- E. Provide continuity at wall intersections by using prefabricated T-shaped units.
- F. Provide continuity at corners by using prefabricated L-shaped units.
- G. Cut and bend reinforcing units as directed by manufacturer for continuity at corners, returns, offsets, column fireproofing, pipe enclosures, and other special conditions.

2.5 REINFORCEMENT

- A. Uncoated Steel Reinforcing Bars: ASTM A 615/A 615M or ASTM A 996/A 996M, Grade 60.
- B. Masonry Joint Reinforcement, General: ASTM A 951/A 951M.
 - 1. Interior Walls: Hot-dip galvanized, carbon steel.
 - 2. Wire Size for Side Rods: 0.187-inch diameter.
 - 3. Wire Size for Cross Rods: 0.187-inch diameter.
 - 4. Wire Size for Veneer Ties: 0.187-inch diameter.
 - 5. Spacing of Cross Rods, Tabs, and Cross Ties: Not more than 16 inches o.c.
 - 6. Provide in lengths of not less than 10 feet.
- C. Masonry Joint Reinforcement for Single-Wythe Masonry: Either ladder or truss type with single pair of side rods.

2.6 TIES AND ANCHORS

- A. Materials: Provide ties and anchors specified in this article that are made from materials that comply with the following unless otherwise indicated.
 - 1. Hot-Dip Galvanized, Carbon-Steel Wire: ASTM A 82/A 82M; with ASTM A 153/A 153M, Class B-2 coating.

- B. Corrugated Metal Ties: Metal strips not less than 7/8 inch wide with corrugations having a wavelength of and an amplitude of 0.06 to 0.10 inch made from 0.060-inch-thick, steel sheet, galvanized after fabrication.
- C. Wire Ties, General: Unless otherwise indicated, size wire ties to extend at least halfway through veneer but with at least 5/8-inch cover on outside face. Outer ends of wires are bent 90 degrees and extend 2 inches parallel to face of veneer.
- D. Individual Wire Ties: Rectangular units with closed ends and not less than 4 inches.
 - 1. Wire: Fabricate from 1/4-inch-diameter, hot-dip galvanized steel.
- E. Adjustable Masonry-Veneer Anchors:
 - 1. General: Provide anchors that allow vertical adjustment but resist tension and compression forces perpendicular to plane of wall, for attachment over sheathing to wood or metal studs, and as follows:
 - a. Structural Performance Characteristics: Capable of withstanding a 100-lb load in both tension and compression without deforming or developing play in excess of 0.05 inch.
 - 2. Contractor's Option: Unless otherwise indicated, provide any of the following types of anchors:
 - 3. Screw-Attached, Masonry-Veneer Anchors: Units consisting of a wire tie and a metal anchor section.
 - a. Products: Subject to compliance with requirements, available products that may be incorporated into the Work include, but are not limited to, the following:
 - 1) Dayton Superior Corporation, Dur-O-Wal Division; D/A 213 or D/A 210 with D/A 700-708.
 - 2) Heckmann Building Products Inc.; 315-D with 316 or Pos-I-Tie.
 - 3) Hohmann & Barnard, Inc.; DW-10 DW-10HS or DW-10-X.
 - b. Anchor Section: Rib-stiffened, sheet metal plate with screw holes top and bottom, 2-3/4 inches wide by 3 inches high; with projecting tabs having slotted holes for inserting vertical legs of wire tie specially formed to fit anchor section.
 - c. Anchor Section: Sheet metal plate, 1-1/4 inches wide by 6 inches long, with screw holes top and bottom and with raised rib-stiffened strap, 5/8 inch wide by 5-1/2 inches long, stamped into center to provide a slot between strap and plate for inserting wire tie.
 - d. Anchor Section: Racketed sheet metal plate, 1-1/4 inches wide by 6 inches long, with screw holes top and bottom; top and bottom ends bent to form pronged legs of length to match thickness of insulation or sheathing; and raised rib-stiffened strap, 5/8 inch wide by 6 inches long, stamped into center to provide a slot between strap and plate for inserting wire tie. Provide anchor manufacturer's standard, self-adhering, modified

bituminous gaskets manufactured to fit behind anchor plate and extend beyond pronged legs.

- e. Anchor Section: Corrosion-resistant, self-drilling, eye-screw designed to receive wire tie. Eye-screw has spacer that seats directly against framing and is same thickness as sheathing and has gasketed, washer head that covers hole in sheathing.
- f. Fabricate sheet metal anchor sections and other sheet metal parts from 1.05-inch-thick, steel sheet, galvanized after fabrication.
- g. Wire Ties: Triangular-, rectangular-, or T-shaped wire ties fabricated from 0.25-inch-diameter, hot-dip galvanized steel wire.

2.7 MISCELLANEOUS ANCHORS

- A. Anchor Bolts: Headed steel bolts complying with ASTM A 307, Grade A; with ASTM A 563 hex nuts and, where indicated, flat washers; hot-dip galvanized to comply with ASTM A 153/A 153M, Class C; of dimensions indicated.
- B. Proprietary Acidic Cleaner: Manufacturer's standard-strength cleaner designed for removing mortar/grout stains, efflorescence, and other new construction stains from new masonry without discoloring or damaging masonry surfaces. Use product expressly approved for intended use by cleaner manufacturer and manufacturer of masonry units being cleaned.
 - 1. Manufacturers: Subject to compliance with requirements, available manufacturers offering products that may be incorporated into the Work include, but are not limited to, the following:
 - a. Diedrich Technologies, Inc.
 - b. EaCo Chem, Inc.
 - c. ProSoCo, Inc.

2.8 MORTAR AND GROUT MIXES

- A. General: Do not use admixtures, including pigments, air-entraining agents, accelerators, retarders, water-repellent agents, antifreeze compounds, or other admixtures, unless otherwise indicated.
 - 1. Do not use calcium chloride in mortar or grout.
 - 2. Use masonry cement mortar unless otherwise indicated.
 - 3. For reinforced masonry, masonry cement mortar.
- B. Mortar for Unit Masonry: Comply with ASTM C 270, Property Specification. Provide the following types of mortar for applications stated.
 - 1. For reinforced masonry, use Type N.
 - 2. For exterior, above-grade, load-bearing and non-load-bearing walls, and parapet walls; for interior load-bearing walls; for interior non-load-bearing partitions; and for other applications where another type is not indicated, use Type N.

PART 3 - EXECUTION

3.1 EXAMINATION

- A. Examine conditions, with Installer present, for compliance with requirements for installation tolerances and other conditions affecting performance of the Work.
 - 1. For the record, prepare written report, endorsed by Installer, listing conditions detrimental to performance of work.
 - 2. Verify that foundations are within tolerances specified.
 - 3. Verify that reinforcing dowels are properly placed.
- B. Before installation, examine rough-in and built-in construction for piping systems to verify actual locations of piping connections.
- C. Proceed with installation only after unsatisfactory conditions have been corrected.

3.2 INSTALLATION, GENERAL

- A. Thickness: Build masonry construction to full thickness shown. Build single-wythe walls to actual widths of masonry units, using units of widths indicated.
- B. Build chases and recesses to accommodate items specified in this and other Sections.
- C. Leave openings for equipment to be installed before completing masonry. After installing equipment, complete masonry to match the construction immediately adjacent to opening.
- D. Use full-size units without cutting if possible. If cutting is required to provide a continuous pattern or to fit adjoining construction, cut units with motor-driven saws; provide clean, sharp, unchipped edges. Allow units to dry before laying unless wetting of units is specified. Install cut units with cut surfaces and, where possible, cut edges concealed.

3.3 TOLERANCES

- A. Dimensions and Locations of Elements:
 - 1. For dimensions in cross section or elevation do not vary by more than plus 1/2 inch or minus 1/4 inch.
 - 2. For location of elements in plan do not vary from that indicated by more than plus or minus 1/2 inch.
 - 3. For location of elements in elevation do not vary from that indicated by more than plus or minus 1/4 inch in a story height or 1/2 inch total.
- B. Lines and Levels:

1. For bed joints and top surfaces of bearing walls do not vary from level by more than 1/4 inch in 10 feet, or 1/2 inch maximum.
2. For conspicuous horizontal lines, such as lintels, sills, do not vary from level by more than 1/8 inch in 10 feet, 1/4 inch in 20 feet or 1/2 inch maximum.
3. For vertical lines and surfaces do not vary from plumb by more than 1/4 inch in 10 feet, 3/8 inch in 20 feet, or 1/2 inch maximum.
4. For conspicuous vertical lines, such as external corners, door jambs, reveals, and expansion and control joints, do not vary from plumb by more than 1/8 inch in 10 feet, 1/4 inch in 20 feet, or 1/2 inch maximum.
5. For lines and surfaces do not vary from straight by more than 1/4 inch in 10 feet, 3/8 inch in 20 feet, or 1/2 inch maximum.
6. For vertical alignment of exposed head joints, do not vary from plumb by more than 1/4 inch in 10 feet, or 1/2 inch maximum.
7. For faces of adjacent exposed masonry units, do not vary from flush alignment by more than 1/16 inch except due to warpage of masonry units within tolerances specified for warpage of units.

C. Joints:

1. For bed joints, do not vary from thickness indicated by more than plus or minus 1/8 inch, with a maximum thickness limited to 1/2 inch.
2. For exposed bed joints, do not vary from bed-joint thickness of adjacent courses by more than 1/8 inch
3. For head and collar joints, do not vary from thickness indicated by more than plus 3/8 inch or minus 1/4 inch
4. For exposed head joints, do not vary from thickness indicated by more than plus or minus 1/8 inch. Do not vary from adjacent bed-joint and head-joint thicknesses by more than 1/8 inch.
5. For exposed bed joints and head joints of stacked bond, do not vary from a straight line by more than 1/16 inch from one masonry unit to the next.

3.4 LAYING MASONRY WALLS

- A. Lay out walls in advance for accurate spacing of surface bond patterns with uniform joint thicknesses and for accurate location of openings, movement-type joints, returns, and offsets. Avoid using less-than-half-size units, particularly at corners, jambs, and, where possible, at other locations.
- B. Bond Pattern for Exposed Masonry: Unless otherwise indicated, lay exposed masonry in running bond; do not use units with less than nominal 4-inch horizontal face dimensions at corners or jambs.
- C. Lay concealed masonry with all units in a wythe in running bond or bonded by lapping not less than 4-inches. Bond and interlock each course of each wythe at corners. Do not use units with less than nominal 4-inch horizontal face dimensions at corners or jambs.
- D. Stopping and Resuming Work: Stop work by racking back units in each course from those in course below; do not tooth. When resuming work, clean masonry surfaces

that are to receive mortar, remove loose masonry units and mortar, and wet brick if required before laying fresh masonry.

- E. Built-in Work: As construction progresses, build in items specified in this and other Sections. Fill in solidly with masonry around built-in items.
- F. Fill space between steel frames and masonry solidly with mortar unless otherwise indicated.
- G. Where built-in items are to be embedded in cores of hollow masonry units, place a layer of metal lath, wire mesh, or plastic mesh in the joint below and rod mortar or grout into core.
- H. Fill cores in hollow CMUs with grout 24 inches under bearing plates, beams, lintels, posts, and similar items unless otherwise indicated.
- I. Build non-load-bearing interior partitions full height of story to underside of solid floor or roof structure above unless otherwise indicated.
 - 1. Install compressible filler in joint between top of partition and underside of structure above.
 - 2. Fasten partition top anchors to structure above and build into top of partition. Grout cells of CMUs solidly around plastic tubes of anchors and push tubes down into grout to provide 1/2-inch clearance between end of anchor rod and end of tube. Space anchors 48 inches o.c. unless otherwise indicated.
 - 3. Wedge non-load-bearing partitions against structure above with small pieces of tile, slate, or metal. Fill joint with mortar after dead-load deflection of structure above approaches final position.
 - 4. At fire-rated partitions, treat joint between top of partition and underside of structure above to comply with Division 07 Section "Fire-Resistive Joint Systems."

3.5 MORTAR BEDDING AND JOINTING

- A. Lay hollow CMUs as follows:
 - 1. With face shells fully bedded in mortar and with head joints of depth equal to bed joints.
 - 2. With webs fully bedded in mortar in all courses of piers, columns, and pilasters.
 - 3. With webs fully bedded in mortar in grouted masonry, including starting course on footings.
 - 4. With entire units, including areas under cells, fully bedded in mortar at starting course on footings where cells are not grouted.

3.6 ANCHORING MASONRY TO STRUCTURAL STEEL AND CONCRETE

- A. Anchor masonry to structural steel and concrete where masonry abuts or faces structural steel or concrete to comply with the following:

1. Provide an open space not less than 1/2 inch wide between masonry and structural steel or concrete unless otherwise indicated. Keep open space free of mortar and other rigid materials.
2. Anchor masonry with anchors embedded in masonry joints and attached to structure.
3. Space anchors as indicated, but not more than 24 inches o.c. vertically and 36 inches o.c. horizontally.

3.7 CONTROL AND EXPANSION JOINTS

- A. General: Install control and expansion joint materials in unit masonry as masonry progresses. Do not allow materials to span control and expansion joints without provision to allow for in-plane wall or partition movement.
- B. Form control joints in concrete masonry as follows:
 1. Install interlocking units designed for control joints. Install bond-breaker strips at joint. Keep head joints free and clear of mortar or rake out joint for application of sealant.
- C. Install steel lintels where indicated.
- D. Provide masonry lintels where shown and where openings of more than 24 inches for block-size units are shown without structural steel or other supporting lintels.
- E. Provide minimum bearing of 8 inches at each jamb unless otherwise indicated.

3.8 FIELD QUALITY CONTROL

- A. Testing and Inspecting: Engage special inspectors to perform tests and inspections and prepare reports. Allow inspectors access to scaffolding and work areas, as needed to perform tests and inspections. Retesting of materials that fail to comply with specified requirements shall be done at Contractor's expense.
- B. Inspections: Level 1 special inspections according to the "International Building Code."
 1. Begin masonry construction only after inspectors have verified proportions of site-prepared mortar.
 2. Place grouts only after inspectors have verified compliance of grout spaces and of grades, sizes, and locations of reinforcement.
 3. Place grout only after inspectors have verified proportions of site-prepared grout.
- C. Testing Prior to Construction: One set of tests.
- D. Testing Frequency: One set of tests for each 5000 sq. ft. of wall area or portion thereof.
- E. Concrete Masonry Unit Test: For each type of unit provided, according to ASTM C 140 for compressive strength.

- F. Mortar Test (Property Specification): For each mix provided, according to ASTM C 780. Test mortar for mortar air content and compressive strength.
- G. Prism Test: For each type of construction provided, according to ASTM C 1314 at 7 days and at 28 days.

3.9 PARGING

- A. Remove and replace masonry units that are loose, chipped, broken, stained, or otherwise damaged or that do not match adjoining units. Install new units to match adjoining units; install in fresh mortar, pointed to eliminate evidence of replacement.
- B. Pointing: During the tooling of joints, enlarge voids and holes, except weep holes, and completely fill with mortar. Point up joints, including corners, openings, and adjacent construction, to provide a neat, uniform appearance. Prepare joints for sealant application, where indicated.
- C. In-Progress Cleaning: Clean unit masonry as work progresses by dry brushing to remove mortar fins and smears before tooling joints.
- D. Final Cleaning: After mortar is thoroughly set and cured, clean exposed masonry as follows:
 - 1. Remove large mortar particles by hand with wooden paddles and nonmetallic scrape hoes or chisels.
 - 2. Test cleaning methods on sample wall panel; leave one-half of panel uncleaned for comparison purposes. Obtain Architect's approval of sample cleaning before proceeding with cleaning of masonry.
 - 3. Protect adjacent stone and non-masonry surfaces from contact with cleaner by covering them with liquid strippable masking agent or polyethylene film and waterproof masking tape.
 - 4. Wet wall surfaces with water before applying cleaners; remove cleaners promptly by rinsing surfaces thoroughly with clear water.
 - 5. Clean brick by bucket-and-brush hand-cleaning method described in BIA Technical Notes 20.
 - 6. Clean masonry with a proprietary acidic cleaner applied according to manufacturer's written instructions.
 - 7. Clean concrete masonry by cleaning method indicated in NCMA TEK 8-2A applicable to type of stain on exposed surfaces.
 - 8. Clean stone trim to comply with stone supplier's written instructions.
 - 9. Clean limestone units to comply with recommendations in ILI's "Indiana Limestone Handbook."

3.10 MASONRY WASTE DISPOSAL

- A. Salvageable Materials: Unless otherwise indicated, excess masonry materials are Contractor's property. At completion of unit masonry work, remove from Project site.

- B. Waste Disposal as Fill Material: Dispose of clean masonry waste, including excess or soil-contaminated sand, waste mortar, and broken masonry units, by crushing and mixing with fill material as fill is placed.
1. Crush masonry waste to less than 4 inches in each dimension.
 2. Mix masonry waste with at least two parts of specified fill material for each part of masonry waste.
 3. Do not dispose of masonry waste as fill within 18 inches of finished grade.
- C. Excess Masonry Waste: Remove excess clean masonry waste that cannot be used as fill, as described above, and other masonry waste, and legally dispose of off Owner's property.

END OF SECTION 042000

SECTION 055000 - METAL FABRICATIONS

PART 1 - GENERAL

1.1 RELATED DOCUMENTS

- A. Drawings and general provisions of the Contract, including General and Supplementary Conditions and Division 01 Specification Sections, apply to this Section.

1.2 SUMMARY

- A. Section Includes:

- 1. Steel framing and supports for mechanical and electrical equipment.
- 2. Steel framing and supports for applications where framing and supports are not specified in other Sections.
- 3. Structural-steel door frames.
- 4. Loose bearing and leveling plates for applications where they are not specified in other Sections.

- B. Products furnished, but not installed, under this Section:

- 1. Loose steel lintels.
- 2. Anchor bolts, steel pipe sleeves, slotted-channel inserts, and wedge-type inserts indicated to be cast into concrete or built into unit masonry.
- 3. Steel weld plates and angles for casting into concrete for applications where they are not specified in other Sections.

- C. Related Sections:

- 1. Section 042000 "Unit Masonry" for installing loose lintels, anchor bolts, and other items built into unit masonry.

1.3 PERFORMANCE REQUIREMENTS

- A. Delegated Design: Design ladders, including comprehensive engineering analysis by a qualified professional engineer, using performance requirements and design criteria indicated.

- B. Thermal Movements: Allow for thermal movements from ambient and surface temperature changes acting on exterior metal fabrications by preventing buckling, opening of joints, overstressing of components, failure of connections, and other detrimental effects.

- 1. Temperature Change: 120 deg F, ambient; 180 deg F, material surfaces.

1.4 ACTION SUBMITTALS

- A. Product Data: For the following:
 - 1. Paint products.
 - 2. Grout.
- B. LEED Submittals:
 - 1. Product Data for Credit MR 4: For products having recycled content, documentation indicating percentages by weight of postconsumer and preconsumer recycled content. Include statement indicating cost for each product having recycled content.
 - 2. Laboratory Test Reports for Credit IEQ 4: For primers, documentation indicating that products comply with the testing and product requirements of the California Department of Health Services' "Standard Practice for the Testing of Volatile Organic Emissions from Various Sources Using Small-Scale Environmental Chambers."
- C. Shop Drawings: Show fabrication and installation details for metal fabrications.
 - 1. Include plans, elevations, sections, and details of metal fabrications and their connections. Show anchorage and accessory items.
- D. Delegated-Design Submittal: For installed products indicated to comply with performance requirements and design criteria, including analysis data signed and sealed by the qualified professional engineer responsible for their preparation.

1.5 INFORMATIONAL SUBMITTALS

- A. Qualification Data: For qualified professional engineer.
- B. Mill Certificates: Signed by manufacturers of stainless-steel certifying that products furnished comply with requirements.
- C. Welding certificates.
- D. Paint Compatibility Certificates: From manufacturers of topcoats applied over shop primers certifying that shop primers are compatible with topcoats.

1.6 QUALITY ASSURANCE

- A. Welding Qualifications: Qualify procedures and personnel according to AWS D1.1/D1.1M, "Structural Welding Code - Steel."
- B. Welding Qualifications: Qualify procedures and personnel according to the following:
 - 1. AWS D1.1/D1.1M, "Structural Welding Code - Steel."
 - 2. AWS D1.2/D1.2M, "Structural Welding Code - Aluminum."

3. AWS D1.6, "Structural Welding Code - Stainless Steel."

1.7 PROJECT CONDITIONS

- A. Field Measurements: Verify actual locations of walls and other construction contiguous with metal fabrications by field measurements before fabrication.

1.8 COORDINATION

- A. Coordinate selection of shop primers with topcoats to be applied over them. Comply with paint and coating manufacturers' written recommendations to ensure that shop primers and topcoats are compatible with one another.
- B. Coordinate installation of anchorages and steel weld plates and angles for casting into concrete. Furnish setting drawings, templates, and directions for installing anchorages, including sleeves, concrete inserts, anchor bolts, and items with integral anchors, that are to be embedded in concrete or masonry. Deliver such items to Project site in time for installation.

PART 2 - PRODUCTS

2.1 METALS, GENERAL

- A. Metal Surfaces, General: Provide materials with smooth, flat surfaces unless otherwise indicated. For metal fabrications exposed to view in the completed Work, provide materials without seam marks, roller marks, rolled trade names, or blemishes.

2.2 FERROUS METALS

- A. Recycled Content of Steel Products: Postconsumer recycled content plus one-half of preconsumer recycled content not less than 25 percent.
- B. Steel Plates, Shapes, and Bars: ASTM A 36/A 36M.
- C. Stainless-Steel Sheet, Strip, and Plate: ASTM A 240/A 240M or ASTM A 666, Type 304.
- D. Stainless-Steel Bars and Shapes: ASTM A 276, Type 304.
- E. Rolled-Steel Floor Plate: ASTM A 786/A 786M, rolled from plate complying with ASTM A 36/A 36M or ASTM A 283/A 283M, Grade C or D.
- F. Rolled-Stainless-Steel Floor Plate: ASTM A 793.
- G. Abrasive-Surface Floor Plate: Steel plate with abrasive granules rolled into surface or with abrasive material metallically bonded to steel.

1. Products: Subject to compliance with requirements, available products that may be incorporated into the Work include, but are not limited to, the following:
 - a. IKG Industries, a division of Harsco Corporation; Mebac.
 - b. SlipNOT Metal Safety Flooring, a W. S. Molnar company; SlipNOT.
- H. Steel Tubing: ASTM A 500, cold-formed steel tubing.
- I. Steel Pipe: ASTM A 53/A 53M, standard weight (Schedule 40) unless otherwise indicated.
- J. Slotted Channel Framing: Cold-formed metal box channels (struts) complying with MFMA-4.
 1. Size of Channels: 1-5/8 by 1-5/8 inches]
 2. Material: Galvanized steel, ASTM A 653/A 653M, structural steel, Grade 33, with G90 coating; 0.108-inch nominal thickness.
 3. Material: Cold-rolled steel, ASTM A 1008/A 1008M, structural steel, Grade 33; 0.0966-inch minimum thickness; hot-dip galvanized after fabrication.
- K. Cast Iron: Either gray iron, ASTM A 48/A 48M, or malleable iron, ASTM A 47/A 47M, unless otherwise indicated.

2.3 NONFERROUS METALS

- A. Aluminum Plate and Sheet: ASTM B 209, Alloy 6061-T6.
- B. Aluminum Extrusions: ASTM B 221, Alloy 6063-T6.
- C. Aluminum-Alloy Rolled Tread Plate: ASTM B 632/B 632M, Alloy 6061-T6.
- D. Aluminum Castings: ASTM B 26/B 26M, Alloy 443.0-F.
- E. Bronze Plate, Sheet, Strip, and Bars: ASTM B 36/B 36M, Alloy UNS No. C28000 (muntz metal, 60 percent copper).
- F. Bronze Extrusions: ASTM B 455, Alloy UNS No. C38500 (extruded architectural bronze).
- G. Bronze Castings: ASTM B 584, Alloy UNS No. C83600 (leaded red brass) or No. C84400 (leaded semired brass).
- H. Nickel Silver Extrusions: ASTM B 151/B 151M, Alloy UNS No. C74500.
- I. Nickel Silver Castings: ASTM B 584, Alloy UNS No. C97600 (20 percent leaded nickel bronze).

2.4 FASTENERS

- A. General: Unless otherwise indicated, provide Type 304 stainless-steel fasteners for exterior use and zinc-plated fasteners with coating complying with ASTM B 633 or ASTM F 1941, Class Fe/Zn 5, at exterior walls. Select fasteners for type, grade, and class required.
 - 1. Provide stainless-steel fasteners for fastening aluminum.
 - 2. Provide stainless-steel fasteners for fastening stainless steel.
 - 3. Provide stainless-steel fasteners for fastening nickel silver.
 - 4. Provide bronze fasteners for fastening bronze.
- B. Steel Bolts and Nuts: Regular hexagon-head bolts, ASTM A 307, Grade A; with hex nuts, ASTM A 563; and, where indicated, flat washers.
- C. Steel Bolts and Nuts: Regular hexagon-head bolts, ASTM A 325, Type 3; with hex nuts, ASTM A 563, Grade C3; and, where indicated, flat washers.
- D. Stainless-Steel Bolts and Nuts: Regular hexagon-head annealed stainless-steel bolts, ASTM F 593; with hex nuts, ASTM F 594; and, where indicated, flat washers; Alloy Group 1.
- E. Anchor Bolts: ASTM F 1554, Grade 36, of dimensions indicated; with nuts, ASTM A 563; and, where indicated, flat washers.
 - 1. Hot-dip galvanize or provide mechanically deposited, zinc coating where item being fastened is indicated to be galvanized.
- F. Eyebolts: ASTM A 489.
- G. Machine Screws: ASME B18.6.3.
- H. Lag Screws: ASME B18.2.1.
- I. Wood Screws: Flat head, ASME B18.6.1.
- J. Plain Washers: Round, ASME B18.22.1.
- K. Lock Washers: Helical, spring type, ASME B18.21.1.
- L. Anchors, General: Anchors capable of sustaining, without failure, a load equal to six times the load imposed when installed in unit masonry and four times the load imposed when installed in concrete, as determined by testing according to ASTM E 488, conducted by a qualified independent testing agency.
- M. Cast-in-Place Anchors in Concrete: Either threaded type or wedge type unless otherwise indicated; galvanized ferrous castings, either ASTM A 47/A 47M malleable iron or ASTM A 27/A 27M cast steel. Provide bolts, washers, and shims as needed, all hot-dip galvanized per ASTM F 2329.
- N. Post-Installed Anchors: Torque-controlled expansion anchors or chemical anchors.

1. Material for Interior Locations: Carbon-steel components zinc plated to comply with ASTM B 633 or ASTM F 1941, Class Fe/Zn 5, unless otherwise indicated.
 2. Material for Exterior Locations and Where Stainless Steel is Indicated: Alloy Group 1 stainless-steel bolts, ASTM F 593, and nuts, ASTM F 594.
- O. Slotted-Channel Inserts: Cold-formed, hot-dip galvanized-steel box channels (struts) complying with MFMA-4, 1-5/8 by 7/8 inches by length indicated with anchor straps or studs not less than 3 inches long at not more than 8 inches o.c. Provide with temporary filler and tee-head bolts, complete with washers and nuts, all zinc-plated to comply with ASTM B 633, Class Fe/Zn 5, as needed for fastening to inserts.

2.5 MISCELLANEOUS MATERIALS

- A. Welding Rods and Bare Electrodes: Select according to AWS specifications for metal alloy welded.
- B. Low-Emitting Materials: Paints and coatings shall comply with the testing and product requirements of the California Department of Health Services' "Standard Practice for the Testing of Volatile Organic Emissions from Various Sources Using Small-Scale Environmental Chambers."
- C. Shop Primers: Provide primers that comply with Section 099113 "Exterior Painting." and Section 099123 Interior Painting.
- D. Universal Shop Primer: Fast-curing, lead- and chromate-free, universal modified-alkyd primer complying with MPI#79 and compatible with topcoat.
1. Use primer containing pigments that make it easily distinguishable from zinc-rich primer.
- E. Epoxy Zinc-Rich Primer: Complying with MPI#20 and compatible with topcoat.
- F. Galvanizing Repair Paint: High-zinc-dust-content paint complying with SSPC-Paint 20 and compatible with paints specified to be used over it.
- G. Bituminous Paint: Cold-applied asphalt emulsion complying with ASTM D 1187.
- H. Nonshrink, Metallic Grout: Factory-packaged, ferrous-aggregate grout complying with ASTM C 1107, specifically recommended by manufacturer for heavy-duty loading applications.
- I. Nonshrink, Nonmetallic Grout: Factory-packaged, nonstaining, noncorrosive, nongaseous grout complying with ASTM C 1107. Provide grout specifically recommended by manufacturer for interior and exterior applications.
- J. Concrete: Comply with requirements in Section 033000 "Cast-in-Place Concrete" for normal-weight, air-entrained, concrete with a minimum 28-day compressive strength of 3000 psi.

2.6 FABRICATION, GENERAL

- A. Shop Assembly: Preassemble items in the shop to greatest extent possible. Disassemble units only as necessary for shipping and handling limitations. Use connections that maintain structural value of joined pieces. Clearly mark units for reassembly and coordinated installation.
- B. Cut, drill, and punch metals cleanly and accurately. Remove burrs and ease edges to a radius of approximately 1/32 inch unless otherwise indicated. Remove sharp or rough areas on exposed surfaces.
- C. Form bent-metal corners to smallest radius possible without causing grain separation or otherwise impairing work.
- D. Form exposed work with accurate angles and surfaces and straight edges.
- E. Weld corners and seams continuously to comply with the following:
 - 1. Use materials and methods that minimize distortion and develop strength and corrosion resistance of base metals.
 - 2. Obtain fusion without undercut or overlap.
 - 3. Remove welding flux immediately.
 - 4. At exposed connections, finish exposed welds and surfaces smooth and blended so no roughness shows after finishing and contour of welded surface matches that of adjacent surface.
- F. Form exposed connections with hairline joints, flush and smooth, using concealed fasteners or welds where possible. Where exposed fasteners are required, use Phillips flat-head (countersunk) fasteners unless otherwise indicated. Locate joints where least conspicuous.
- G. Fabricate seams and other connections that will be exposed to weather in a manner to exclude water. Provide weep holes where water may accumulate.
- H. Cut, reinforce, drill, and tap metal fabrications as indicated to receive finish hardware, screws, and similar items.
- I. Provide for anchorage of type indicated; coordinate with supporting structure. Space anchoring devices to secure metal fabrications rigidly in place and to support indicated loads.
 - 1. Where units are indicated to be cast into concrete or built into masonry, equip with integrally welded steel strap anchors, 1/8 by 1-1/2 inches, with a minimum 6-inch embedment and 2-inch hook, not less than 8 inches from ends and corners of units and 24 inches o.c., unless otherwise indicated.

2.7 MISCELLANEOUS FRAMING AND SUPPORTS

- A. General: Provide steel framing and supports not specified in other Sections as needed to complete the Work.

- B. Fabricate units from steel shapes, plates, and bars of welded construction unless otherwise indicated. Fabricate to sizes, shapes, and profiles indicated and as necessary to receive adjacent construction.
 - 1. Fabricate units from slotted channel framing where indicated.
 - 2. Furnish inserts for units installed after concrete is placed.
- C. Galvanize miscellaneous framing and supports where indicated.
- D. Prime miscellaneous framing and supports with zinc-rich primer where indicated.

2.8 STRUCTURAL-STEEL DOOR FRAMES

- A. Fabricate structural-steel door frames from steel shapes, plates, and bars of size and to dimensions indicated, fully welded together, with 5/8-by-1-1/2-inch steel channel stops, unless otherwise indicated. Plug-weld built-up members and continuously weld exposed joints. Secure removable stops to frame with countersunk machine screws, uniformly spaced at not more than 10 inches o.c. Reinforce frames and drill and tap as necessary to accept finish hardware.
 - 1. Provide with integrally welded steel strap anchors for securing door frames into adjoining concrete or masonry.
- B. Extend bottom of frames to floor elevation indicated with steel angle clips welded to frames for anchoring frame to floor with expansion shields and bolts.
- C. Galvanize exterior steel frames.

2.9 MISCELLANEOUS STEEL TRIM

- A. Unless otherwise indicated, fabricate units from steel shapes, plates, and bars of profiles shown with continuously welded joints and smooth exposed edges. Miter corners and use concealed field splices where possible.
- B. Provide cutouts, fittings, and anchorages as needed to coordinate assembly and installation with other work.
 - 1. Provide with integrally welded steel strap anchors for embedding in concrete or masonry construction.
- C. Galvanize exterior miscellaneous steel trim.
- D. Prime exterior miscellaneous steel trim with zinc-rich primer.

2.10 LOOSE BEARING AND LEVELING PLATES

- A. Provide loose bearing and leveling plates for steel items bearing on masonry or concrete construction. Drill plates to receive anchor bolts and for grouting.

- B. Galvanize plates.
- C. Prime plates with zinc-rich primer.

2.11 LOOSE STEEL LINTELS

- A. Fabricate loose steel lintels from steel angles and shapes of size indicated for openings and recesses in masonry walls and partitions at locations indicated. Fabricate in single lengths for each opening unless otherwise indicated. Weld adjoining members together to form a single unit where indicated.
- B. Size loose lintels to provide bearing length at each side of openings equal to 1/12 of clear span but not less than 8 inches unless otherwise indicated.
- C. Galvanize loose steel lintels located in exterior walls.
- D. Prime loose steel lintels located in exterior walls with zinc-rich primer.

2.12 STEEL WELD PLATES AND ANGLES

- A. Provide steel weld plates and angles not specified in other Sections, for items supported from concrete construction as needed to complete the Work. Provide each unit with no fewer than two integrally welded steel strap anchors for embedding in concrete.

2.13 FINISHES, GENERAL

- A. Comply with NAAMM's "Metal Finishes Manual for Architectural and Metal Products" for recommendations for applying and designating finishes.
- B. Finish metal fabrications after assembly.
- C. Finish exposed surfaces to remove tool and die marks and stretch lines, and to blend into surrounding surface.

2.14 STEEL AND IRON FINISHES

- A. Galvanizing: Hot-dip galvanize items as indicated to comply with ASTM A 153/A 153M for steel and iron hardware and with ASTM A 123/A 123M for other steel and iron products.
 - 1. Do not quench or apply post galvanizing treatments that might interfere with paint adhesion.
- B. Shop prime iron and steel items unless they are to be embedded in concrete, sprayed-on fireproofing, or masonry, or unless otherwise indicated.

1. Shop prime with primers specified in Section 099113 "Exterior Painting" and primers specified in Section 099123 "Interior Painting" unless zinc-rich primer is indicated or necessary.
- C. Preparation for Shop Priming: Prepare surfaces to comply with requirements indicated below:
1. Exterior Items: SSPC-SP 6/NACE No. 3, "Commercial Blast Cleaning."
 2. Items Indicated to Receive Zinc-Rich Primer: SSPC-SP 6/NACE No. 3, "Commercial Blast Cleaning."
 3. Items Indicated to Receive Primers Specified in Section 099600 "High-Performance Coatings": SSPC-SP 6/NACE No. 3, "Commercial Blast Cleaning."
 4. Other Items: SSPC-SP 3, "Power Tool Cleaning."
- D. Shop Priming: Apply shop primer to comply with SSPC-PA 1, "Paint Application Specification No. 1: Shop, Field, and Maintenance Painting of Steel," for shop painting.
1. Stripe paint corners, crevices, bolts, welds, and sharp edges.

PART 3 - EXECUTION

3.1 INSTALLATION, GENERAL

- A. Cutting, Fitting, and Placement: Perform cutting, drilling, and fitting required for installing metal fabrications. Set metal fabrications accurately in location, alignment, and elevation; with edges and surfaces level, plumb, true, and free of rack; and measured from established lines and levels.
- B. Fit exposed connections accurately together to form hairline joints. Weld connections that are not to be left as exposed joints but cannot be shop welded because of shipping size limitations. Do not weld, cut, or abrade surfaces of exterior units that have been hot-dip galvanized after fabrication and are for bolted or screwed field connections.
- C. Field Welding: Comply with the following requirements:
1. Use materials and methods that minimize distortion and develop strength and corrosion resistance of base metals.
 2. Obtain fusion without undercut or overlap.
 3. Remove welding flux immediately.
 4. At exposed connections, finish exposed welds and surfaces smooth and blended so no roughness shows after finishing and contour of welded surface matches that of adjacent surface.
- D. Fastening to In-Place Construction: Provide anchorage devices and fasteners where metal fabrications are required to be fastened to in-place construction. Provide threaded fasteners for use with concrete and masonry inserts, toggle bolts, through bolts, lag screws, wood screws, and other connectors.

- E. Provide temporary bracing or anchors in formwork for items that are to be built into concrete, masonry, or similar construction.
- F. Corrosion Protection: Coat concealed surfaces of aluminum that will come into contact with grout, concrete, masonry, wood, or dissimilar metals with the following:
 - 1. Cast Aluminum: Heavy coat of bituminous paint.
 - 2. Extruded Aluminum: Two coats of clear lacquer.

3.2 INSTALLING MISCELLANEOUS FRAMING AND SUPPORTS

- A. General: Install framing and supports to comply with requirements of items being supported, including manufacturers' written instructions and requirements indicated on Shop Drawings.
- B. Anchor supports for operable partitions securely to and rigidly brace from building structure.
- C. Support steel girders on solid grouted masonry, concrete, or steel pipe columns. Secure girders with anchor bolts embedded in grouted masonry or concrete or with bolts through top plates of pipe columns.
 - 1. Where grout space under bearing plates is indicated for girders supported on concrete or masonry, install as specified in "Installing Bearing and Leveling Plates" Article.
- D. Install pipe columns on concrete footings with grouted baseplates. Position and grout column baseplates as specified in "Installing Bearing and Leveling Plates" Article.
 - 1. Grout baseplates of columns supporting steel girders after girders are installed and leveled.

3.3 INSTALLING BEARING AND LEVELING PLATES

- A. Clean concrete and masonry bearing surfaces of bond-reducing materials, and roughen to improve bond to surfaces. Clean bottom surface of plates.
- B. Set bearing and leveling plates on wedges, shims, or leveling nuts. After bearing members have been positioned and plumbed, tighten anchor bolts. Do not remove wedges or shims but, if protruding, cut off flush with edge of bearing plate before packing with grout.
 - 1. Use nonshrink grout, either metallic or nonmetallic, in concealed locations where not exposed to moisture; use nonshrink, nonmetallic grout in exposed locations unless otherwise indicated.
 - 2. Pack grout solidly between bearing surfaces and plates to ensure that no voids remain.

3.4 ADJUSTING AND CLEANING

- A. Touchup Painting: Immediately after erection, clean field welds, bolted connections, and abraded areas. Paint uncoated and abraded areas with the same material as used for shop painting to comply with SSPC-PA 1 for touching up shop-painted surfaces.
 - 1. Apply by brush or spray to provide a minimum 2.0-mil dry film thickness.
- B. Touchup Painting: Cleaning and touchup painting of field welds, bolted connections, and abraded areas of shop paint are specified in Section 099113 "Exterior Painting." and Section 099123 "Interior Painting."
- C. Galvanized Surfaces: Clean field welds, bolted connections, and abraded areas and repair galvanizing to comply with ASTM A 780.

END OF SECTION 055000

SECTION 055319 - EXPANDED METAL GRATINGS

PART 1 - GENERAL

1.1 RELATED DOCUMENTS

- A. Drawings and general provisions of the Contract, including General and Supplementary Conditions and Division 01 Specification Sections, apply to this Section.

1.2 SUMMARY

- A. Section includes expanded metal gratings/wall panels and metal frames and supports for gratings.

1.3 COORDINATION

- A. Coordinate selection of shop primers with topcoats to be applied over them. Comply with paint and coating manufacturers' written instructions to ensure that shop primers and topcoats are compatible with one another.
- B. Coordinate installation of anchorages for gratings, grating frames, and supports. Furnish setting drawings, templates, and directions for installing anchorages, including sleeves, concrete inserts, anchor bolts, and items with integral anchors, that are embedded in concrete or masonry. Deliver such items to Project site in time for installation.

1.4 ACTION SUBMITTALS

- A. Product Data: For paint products.
- B. Sustainable Design Submittals:
 - 1. **Product Data:** For recycled content, indicating postconsumer and preconsumer recycled content and cost.
- C. Shop Drawings: Include plans, sections, details, and attachments to other work.
- D. Delegated-Design Submittal: For gratings, including analysis data signed and sealed by the qualified professional engineer responsible for their preparation.

1.5 INFORMATIONAL SUBMITTALS

- A. Mill Certificates: Signed by manufacturers of stainless steel certifying that products furnished comply with requirements.

- B. Welding certificates.
- C. Paint Compatibility Certificates: From manufacturers of topcoats applied over shop primers certifying that shop primers are compatible with topcoats.

1.6 QUALITY ASSURANCE

- A. Welding Qualifications: Qualify procedures and personnel according to the following:
 - 1. AWS D1.1/D1.1M, "Structural Welding Code - Steel."
 - 2. AWS D1.3/D1.3M, "Structural Welding Code - Sheet Steel."
 - 3. AWS D1.6/D1.6M, "Structural Welding Code - Stainless Steel."

PART 2 - PRODUCTS

2.1 MANUFACTURERS

- A. Manufacturers: Subject to compliance with requirements, available manufacturers offering products that may be incorporated into the Work include, but are not limited to the following:
 - 1. Alabama Metal Industries Company; a Gibraltar Industries company.
 - 2. All American Grating.
 - 3. Central Expanded Metal, Inc.
 - 4. Fisher & Ludlow; a NUCOR Company.
 - 5. Habersham Metal Products Company
 - 6. McNichol's Company.

2.2 PERFORMANCE REQUIREMENTS

- A. Delegated Design: Engage a qualified professional engineer, as defined in Section 014000 "Quality Requirements," to design gratings.
- B. Structural Performance: Gratings shall withstand the effects of gravity loads and the following loads and stresses within limits and under conditions indicated:
 - 1. Floors and Wall Panels: Uniform load of 125 lbf/sq. ft. or concentrated load of 2000 lbf, whichever produces the greater stress.
 - 2. Walkways and Elevated Platforms Other Than Exits: Uniform load of 60 lbf/sq. ft..
 - 3. Walkways and Elevated Platforms Used as Exits: Uniform load of 100 lbf/sq. ft..
 - 4. Sidewalks and Vehicular Driveways, Subject to Trucking: Uniform load of 250 lbf/sq. ft. or concentrated load of 8000 lbf, whichever produces the greater stress.
 - 5. Limit deflection to L/360 or 1/4 inch, whichever is less.
- C. Seismic Performance: Gratings shall withstand the effects of earthquake motions determined according to ASCE/SEI 7.

1. Component Importance Factor: 1.5.

2.3 EXPANDED METAL GRATINGS

- A. Provide expanded metal gratings in material, finish, style, size, thickness, weight, and type indicated or, if not indicated, as recommended by manufacturer for indicated applications and as needed to support indicated loads.
 1. Material: Stainless steel.
 2. Stainless-Steel Finish: Mill finish, as fabricated.
 3. Style Designation: 3/4 number 9.
 4. Type: II, expanded and flattened.

2.4 FERROUS METALS

- A. Recycled Content of Steel Products: Postconsumer recycled content plus one-half of preconsumer recycled content not less than 25 percent.
- B. Steel Plates, Shapes, and Bars: ASTM A 36/A 36M.
- C. Stainless-Steel Sheet, Strip, Plate, and Flat Bars: ASTM A 240/A 240M, Type 304 or Type 316L.
- D. Stainless-Steel Bars and Shapes: ASTM A 276, Type 304 or Type 316L.
- E. Expanded Metal Stainless Steel: ASTM F 1267, Class 3, made from stainless-steel sheet, ASTM A 240/A 240M, Type 304 or Type 316L.

2.5 FASTENERS

- A. General: Unless otherwise indicated, provide Type 304 or Type 316 stainless-steel fasteners for exterior or interior use and zinc-plated fasteners with coating complying with ASTM B 633 or ASTM F 1941, Class Fe/Zn 5, at exterior walls. Select fasteners for type, grade, and class required.
 1. Provide stainless-steel fasteners for fastening aluminum.
 2. Provide stainless-steel fasteners for fastening stainless steel.
- B. Stainless-Steel Bolts and Nuts: Regular hexagon-head annealed stainless-steel bolts, nuts, and, where indicated, flat washers; ASTM F 593 for bolts and ASTM F 594 for nuts, Alloy Group 1 for Type 304 or Group 2 for Type 316.
- C. Anchor Bolts: ASTM F 1554, Grade 36, of dimensions indicated; with nuts, ASTM A 563; and, where indicated, flat washers.
 1. Hot-dip galvanize or provide mechanically deposited, zinc coating where item being fastened is indicated to be galvanized.

- D. Post-Installed Anchors: Torque-controlled expansion or chemical anchors capable of sustaining, without failure, a load equal to six times the load imposed when installed in unit masonry and four times the load imposed when installed in concrete, as determined by testing according to ASTM E 488/E 488M, conducted by a qualified independent testing agency.
 - 1. Material for Interior or Exterior Locations and Where Stainless Steel Is Indicated: Alloy Group 1 for Type 304 or Group 2 for Type 316 stainless-steel bolts, ASTM F 593, and nuts, ASTM F 594.

2.6 MISCELLANEOUS MATERIALS

- A. Shop Primers: Provide primers that comply with Section 099123 "Interior Painting."
- B. Universal Shop Primer: Fast-curing, lead- and chromate-free, universal modified-alkyd primer complying with MPI#79 and compatible with topcoat.
 - 1. Use primer containing pigments that make it easily distinguishable from zinc-rich primer.
- C. Epoxy Zinc-Rich Primer: Complying with MPI#20 and compatible with topcoat.
- D. Galvanizing Repair Paint: High-zinc-dust-content paint complying with SSPC-Paint 20 and compatible with paints specified to be used over it.

2.7 FABRICATION

- A. Cut, drill, and punch material cleanly and accurately. Remove burrs and ease edges to a radius of approximately 1/32 inch unless otherwise indicated. Remove sharp or rough areas on exposed surfaces.
- B. Form from materials of size, thickness, and shapes indicated, but not less than that needed to support indicated loads.
- C. Fit exposed connections accurately together to form hairline joints.
- D. Welding: Comply with AWS recommendations and the following:
 - 1. Use materials and methods that minimize distortion and develop strength and corrosion resistance of base metals.
 - 2. Obtain fusion without undercut or overlap.
 - 3. Remove welding flux immediately.
- E. Provide for anchorage of type indicated; coordinate with supporting structure. Fabricate and space the anchoring devices to secure gratings, frames, and supports rigidly in place and to support indicated loads.
 - 1. Fabricate toeplates for attaching in the field.
 - 2. Toeplate Height: 4 inches unless otherwise indicated.

- F. Fabricate cutouts in grating sections for penetrations of sizes and at locations indicated. Cut openings neatly and accurately to size. Edge-band openings with bars having a thickness not less than overall grating thickness at contact points.
- G. Where gratings are pierced by pipes, ducts, and structural members, cut openings neatly and accurately to size and weld a strap collar not less than 1/8 inch thick to the cut ends. Divide panels into sections only to the extent required for installation where grating platforms and runways are to be placed around previously installed pipe, ducts, and structural members.

2.8 GRATING FRAMES AND SUPPORTS

- A. Frames and Supports for Metal Gratings: Fabricate from metal shapes, plates, and bars of welded construction to sizes, shapes, and profiles indicated and as necessary to receive gratings. Miter and weld connections for perimeter angle frames. Cut, drill, and tap units to receive hardware and similar items.
 - 1. Unless otherwise indicated, fabricate from same basic metal as gratings.
 - 2. Equip units indicated to be cast into concrete or built into masonry with integrally welded anchors. Unless otherwise indicated, space anchors 24 inches o.c. and provide minimum anchor units in the form of steel straps 1-1/4 inches wide by 1/4 inch thick by 8 inches long.
- B. Stainless steel frames and supports in the following locations:
 - 1. Exterior.
 - 2. Interior, Laundry Room.

2.9 STEEL FINISHES

- A. Finish gratings, frames, and supports after assembly.
- B. Galvanizing: Hot-dip galvanize items as indicated to comply with ASTM A 153/A 153M for steel and iron hardware and with ASTM A 123/A 123M for other steel and iron products.
 - 1. Do not quench or apply post galvanizing treatments that might interfere with paint adhesion.
- C. Shop Priming: Apply shop primer to comply with SSPC-PA 1, "Paint Application Specification No. 1: Shop, Field, and Maintenance Painting of Steel," for shop painting.

PART 3 - EXECUTION

3.1 INSTALLATION, GENERAL

- A. Fastening to In-Place Construction: Provide anchorage devices and fasteners where necessary for securing gratings to in-place construction. Include threaded fasteners for concrete and masonry inserts, through-bolts, lag bolts, and other connectors.
- B. Cutting, Fitting, and Placement: Perform cutting, drilling, and fitting required for installing gratings. Set units accurately in location, alignment, and elevation; measured from established lines and levels and free of rack.
- C. Provide temporary bracing or anchors in formwork for items that are to be built into concrete or masonry.
- D. Fit exposed connections accurately together to form hairline joints.
 - 1. Weld connections that are not to be left as exposed joints but cannot be shop welded because of shipping size limitations. Do not weld, cut, or abrade the surfaces of exterior units that have been hot-dip galvanized after fabrication and are for bolted or screwed field connections.
- E. Attach toeplates to gratings by welding at locations indicated.
- F. Field Welding: Comply with AWS recommendations and the following:
 - 1. Use materials and methods that minimize distortion and develop strength and corrosion resistance of base metals.
 - 2. Obtain fusion without undercut or overlap.
 - 3. Remove welding flux immediately.

3.2 INSTALLING EXPANDED METAL GRATINGS

- A. General: Comply with manufacturer's written instructions for installing gratings.
- B. Place units with straight edge of bond up and with long direction of diamond-shaped openings parallel to direction of span.
- C. Attach removable units to supporting members by bolting at 6-inch intervals.
- D. Attach nonremovable units to supporting members by welding unless otherwise indicated. Space welds at 6-inch intervals.

3.3 ADJUSTING AND CLEANING

- A. Touchup Painting: Immediately after erection, clean field welds, bolted connections, and abraded areas of shop paint, and paint exposed areas with same material as used for shop painting to comply with SSPC-PA 1 requirements for touching up shop-painted surfaces.

1. Apply by brush or spray to provide a minimum 2.0-mil dry film thickness.

- B. Galvanized Surfaces: Clean field welds, bolted connections, and abraded areas and repair galvanizing to comply with ASTM A 780/A 780M.

END OF SECTION 055319

SECTION 072100 - THERMAL INSULATION

PART 1 - GENERAL

1.1 RELATED DOCUMENTS

- A. Drawings and general provisions of the Contract, including General and Supplementary Conditions and Division 01 Specification Sections, apply to this Section.

1.2 SUMMARY

- A. Section Includes:
 - 1. Glass-fiber board insulation.
 - 2. Mineral-wool board insulation.
 - 3. Radiant barriers.
 - 4. Vapor retarders.

1.3 ACTION SUBMITTALS

- A. Product Data: For each type of product indicated.
- B. LEED Submittals:
 - 1. Product Data for Credit MR 4: For products having recycled content, documentation indicating percentages by weight of postconsumer and preconsumer recycled content. Include statement-indicating cost for each product having recycled content.

1.4 INFORMATIONAL SUBMITTALS

- A. Product Test Reports: Based on evaluation of comprehensive tests performed by a qualified testing agency, for each product.

1.5 QUALITY ASSURANCE

- A. Surface-Burning Characteristics: As determined by testing identical products according to ASTM E 84 by a qualified testing agency. Identify products with appropriate markings of applicable testing agency.

1.6 DELIVERY, STORAGE, AND HANDLING

- A. Protect insulation materials from physical damage and from deterioration due to moisture, soiling, and other sources. Store inside and in a dry location. Comply with manufacturer's written instructions for handling, storing, and protecting during installation.

PART 2 - PRODUCTS

2.1 GLASS-FIBER BOARD INSULATION

- A. Manufacturers: Subject to compliance with requirements, provide products by one of the following:
 - 1. CertainTeed Corporation.
 - 2. Johns Manville; a Berkshire Hathaway company.
 - 3. Knauf Insulation.
 - 4. Owens Corning.
- B. Recycled Content: Postconsumer recycled content plus one-half of preconsumer recycled content not less than 10 percent.
- C. Foil-Faced, Glass-Fiber Board Insulation: ASTM C 612, Type IA; faced on one side with foil-scrim-kraft or foil-scrim-polyethylene vapor retarder, with maximum flame-spread and smoke-developed indexes of 25 and 50, respectively, per ASTM E 84.
 - 1. Nominal density of 4.25 lb/cu. ft., thermal resistivity of 4.3 deg F x h x sq. ft./Btu x in. at 75 deg F.
- D. Sustainability Requirements: Provide glass-fiber board insulation as follows:
 - 1. Free of Formaldehyde: Insulation manufactured with 100 percent acrylic binders and no formaldehyde.
 - 2. Low Emitting: Insulation tested according to ASTM D 5116 and shown to emit less than 0.05-ppm formaldehyde.

2.2 MINERAL-WOOL BOARD INSULATION

- A. Manufacturers: Subject to compliance with requirements, provide products by one of the following:
 - 1. Isolatek International.
 - 2. Roxul Inc.
 - 3. Thermafiber, Inc.; an Owens Corning company.
- B. Recycled Content: Postconsumer recycled content plus one-half of preconsumer recycled content not less than 10 percent.

- C. Foil-Faced, Mineral-Wool Board Insulation: ASTM C 612; faced on one side with foil-scrim or foil-scrim-polyethylene vapor retarder; with maximum flame-spread and smoke-developed indexes of 25 and 5, respectively, per ASTM E 84.
1. Nominal density of 4 lb/cu. ft., Types IA and IB, thermal resistivity of 4 deg F x h x sq. ft./Btu x in. at 75 deg F.
 2. Nominal density of 6 lb/cu. ft., Type II, thermal resistivity of 4.16 deg F x h x sq. ft./Btu x in. at 75 deg F.

2.3 RADIANT BARRIERS

- A. Sheet Radiant Barriers: ASTM C 1313 and as follows:

1. Manufacturers: Subject to compliance with requirements, provide products by one of the following:
 - a. Fi-Foil Company.
 - b. Innovative Energy, Inc.
 - c. Innovative Insulation, Inc.
 - d. TVM Building Products.
2. Sheet Construction: Foil on one side of substrate.
3. Surface-Burning Characteristics: Maximum flame-spread and smoke-developed indexes of 5 and 10, respectively.
4. Tear Resistance: 38 pounds per square inch per ASTM 2261.
5. Water-Vapor Transmission: 1 perm, maximum.
6. Sheet Width: To suit field installation.

- B. Interior Radiation Control Coating System: Silver-colored, not thickness-dependent, low-emissivity, water-based coating; formulated for adherence to substrates indicated and with a surface emittance value of 0.25 or less as measured per ASTM C 1371.

1. Manufacturers: Subject to compliance with requirements, provide products by the following:
 - a. SOLEC Corporation.

2.4 VAPOR RETARDERS

- A. Polyethylene Vapor Retarders: ASTM D 4397, 10 mils thick, with maximum permeance rating of 0.13 perm.
- B. Fire-Retardant, Reinforced-Polyethylene Vapor Retarders: Two outer layers of polyethylene film laminated to an inner reinforcing layer consisting of either nonwoven grid of nylon cord or polyester scrim and weighing not less than 22 lb/1000 sq. ft., with maximum permeance rating of 0.1317 perm and with flame-spread and smoke-developed indexes of not more than 5 and 60, respectively, per ASTM E 84.

1. **Manufacturers:** Subject to compliance with requirements, provide products by one of the following:
 - a. [Raven Industries, Inc.](#)
 - b. [Reef Industries, Inc.](#)
- C. Vapor-Retarder Tape: Pressure-sensitive tape of type recommended by vapor-retarder manufacturer for sealing joints and penetrations in vapor retarder.
- D. Vapor-Retarder Fasteners: Pancake-head, self-tapping steel drill screws; with fender washers.
- E. Single-Component Nonsag Urethane Sealant: ASTM C 920, Type I, Grade NS, Class 25, Use NT related to exposure, and Use O related to vapor-barrier-related substrates.
- F. Adhesive for Vapor Retarders: Product recommended by vapor-retarder manufacturer and has demonstrated capability to bond vapor retarders securely to substrates indicated.

2.5 INSULATION FASTENERS

- A. Adhesively Attached, Spindle-Type Anchors: Plate welded to projecting spindle; capable of holding insulation of specified thickness securely in position indicated with self-locking washer in place.
 1. **Manufacturers:** Subject to compliance with requirements, provide products by one of the following:
 - a. [AGM Industries, Inc.](#)
 - b. [Gemco.](#)
 2. Plate: Perforated, galvanized carbon-steel sheet, 0.030 inch thick by 2 inches square.
 3. Spindle: Copper-coated, low-carbon steel; fully annealed; 0.105 inch in diameter; length to suit depth of insulation indicated.
- B. Adhesively Attached, Angle-Shaped, Spindle-Type Anchors: Angle welded to projecting spindle; capable of holding insulation of specified thickness securely in position indicated with self-locking washer in place.
 1. **Manufacturers:** Subject to compliance with requirements, provide products by the following:
 - a. [Gemco.](#)
 2. Angle: Formed from 0.030-inch-thick, perforated, galvanized carbon-steel sheet with each leg 2 inches square.
 3. Spindle: Copper-coated, low-carbon steel; fully annealed; 0.105 inch in diameter; length to suit depth of insulation indicated.

- C. Insulation-Retaining Washers: Self-locking washers formed from 0.016-inch-thick galvanized-steel sheet, with beveled edge for increased stiffness, sized as required to hold insulation securely in place, but not less than 1-1/2 inches square or in diameter.
1. Manufacturers: Subject to compliance with requirements, provide products by one of the following:
 - a. AGM Industries, Inc.
 - b. Gemco.
 2. Protect ends with capped self-locking washers incorporating a spring steel insert to ensure permanent retention of cap in the following locations:
 - a. Crawl spaces.
 - b. Ceiling plenums.
 - c. Attic spaces.
 - d. Where indicated.
- D. Insulation Standoff: Spacer fabricated from galvanized mild-steel sheet for fitting over spindle of insulation anchor to maintain air space of 1 inch between face of insulation and substrate to which anchor is attached.
1. Manufacturers: Subject to compliance with requirements, provide products by the following:
 - a. Gemco.
- E. Anchor Adhesive: Product with demonstrated capability to bond insulation anchors securely to substrates indicated without damaging insulation, fasteners, and substrates.
1. Manufacturers: Subject to compliance with requirements, provide products by one of the following:
 - a. AGM Industries, Inc.
 - b. Gemco.

PART 3 - EXECUTION

3.1 PREPARATION

- A. Clean substrates of substances that are harmful to insulation or vapor retarders, including removing projections capable of puncturing vapor retarders, or that interfere with insulation attachment.

3.2 INSTALLATION, GENERAL

- A. Comply with insulation manufacturer's written instructions applicable to products and applications indicated.
- B. Install insulation that is undamaged, dry, and unsoiled and that has not been left exposed to ice, rain, or snow at any time.
- C. Extend insulation to envelop entire area to be insulated. Cut and fit tightly around obstructions and fill voids with insulation. Remove projections that interfere with placement.
- D. Provide sizes to fit applications indicated and selected from manufacturer's standard thicknesses, widths, and lengths. Apply single layer of insulation units to produce thickness indicated unless multiple layers are otherwise shown or required to make up total thickness.

3.3 INSTALLATION OF RADIANT BARRIERS

- A. Install interior radiation control coating system according to ASTM C 1321.
- B. Install sheet radiant barriers according to ASTM C 1158.
- C. Install radiant barrier for the project work areas to minimize the surface exposure, and the obstructions shall be boxed in with access as required for controls and/or valves.

3.4 INSTALLATION OF INSULATION FOR CONCRETE SUBSTRATES

- A. Relocate any lights, sprinklers, fire alarm, and other ceiling- or wall-mounted devices to the new insulated surface. Prepare all surfaces properly for new work, including scrapping, patching, and primer painting.
- B. Install board insulation on concrete substrates by adhesively attached, spindle-type insulation anchors as follows:
 - 1. Fasten insulation anchors to concrete substrates with insulation anchor adhesive according to anchor manufacturer's written instructions. Space anchors according to insulation manufacturer's written instructions for insulation type, thickness, and application indicated.
 - 2. Apply insulation standoffs to each spindle to create cavity width indicated between concrete substrate and insulation.
 - 3. After adhesive has dried, install board insulation by pressing insulation into position over spindles and securing it tightly in place with insulation-retaining washers, taking care not to compress insulation below indicated thickness.
 - 4. Where insulation will not be covered by other building materials, apply capped washers to tips of spindles.

3.5 INSTALLATION OF VAPOR RETARDERS

- A. Place vapor retarders on side of construction indicated on Drawings. Extend vapor retarders to extremities of areas to protect from vapor transmission. Secure vapor retarders in place with adhesives or other anchorage system as indicated. Extend vapor retarders to cover miscellaneous voids in insulated substrates, including those filled with loose-fiber insulation.
- B. Seal vertical joints in vapor retarders over framing by lapping no fewer than two studs.
 - 1. Fasten vapor retarders to wood framing at top, end, and bottom edges; at perimeter of wall openings; and at lap joints. Space fasteners 16 inches o.c.
 - 2. Before installing vapor retarders, apply urethane sealant to flanges of metal framing including runner tracks, metal studs, and framing around door and window openings. Seal overlapping joints in vapor retarders with vapor-retarder tape according to vapor-retarder manufacturer's written instructions. Seal butt joints with vapor-retarder tape. Locate all joints over framing members or other solid substrates.
 - 3. Firmly attach vapor retarders to metal framing and solid substrates with vapor-retarder fasteners as recommended by vapor-retarder manufacturer.
- C. Seal joints caused by pipes, conduits, electrical boxes, and similar items penetrating vapor retarders with vapor-retarder tape to create an airtight seal between penetrating objects and vapor retarders.
- D. Repair tears or punctures in vapor retarders immediately before concealment by other work. Cover with vapor-retarder tape or another layer of vapor retarders.

3.6 PROTECTION

- A. Protect installed insulation and vapor retarders from damage due to harmful weather exposures, physical abuse, and other causes. Provide temporary coverings or enclosures where insulation is subject to abuse and cannot be concealed and protected by permanent construction immediately after installation.

3.7 INSULATION SCHEDULE

- A. Insulation Type I-1: Foil-faced, glass-fiber board insulation with radiant barriers.
- B. Insulation Type I-2: Foil-faced, mineral-wool board insulation with radiant barriers.

END OF SECTION 072100

SECTION 078413–PENETRATION FIRESTOPPING

PART 1 - GENERAL

1.1 RELATED DOCUMENTS

- A. Drawings and general provisions of the Contract, including General and Supplementary Conditions and other Division 1 Specification Sections, apply to this Section.

1.2 SECTION INCLUDES

- A. Sealing of penetrations including, but not limited to, the following conditions:
 - 1. Fire-resistance-rated construction including both empty openings and openings containing cables, pipes, ducts, conduits, and other penetrating items.
 - 2. Smoke barriers and construction enclosing compartmentalized areas involving both empty openings and openings containing penetrating items.
 - 3. Sealant joints in fire-resistance-rated and smoke barrier construction.
- B. Sealing of voids, joints, and openings between rated assemblies such as wall to wall, wall to floor and wall to roof construction to meet designated fire and smoke ratings.
- C. Sealing of voids, joints, openings, and penetrations at construction assemblies to meet Code and local regulations.

1.3 RELATED SECTIONS

- A. Section 079200, "Joint Sealants."
- B. Section 111990, "Detention Equipment General Requirements" for conduits, and other devices that penetrate or must pass through assemblies.
- C. Division 26 sections for conduits, and other devices that penetrate or must pass through rated assemblies for electrical systems.

1.4 SYSTEM PERFORMANCE REQUIREMENTS

- A. General: Provide firestop systems that are tested, produced and installed to resist spread of fire and passage of smoke and other gases for each rated system assembly in compliance with UL.
- B. F-Rated Through-Penetration Firestop Systems: ASTM E 814, through-penetration firestop systems with F ratings indicated, but not less than that equaling or exceeding the fire-resistance rating of the constructions penetrated.

- C. T-Rated Through-Penetration Firestop Systems: ASTM E 814, through-penetration firestop systems with T-ratings, in addition to F-ratings, where indicated and where systems protect penetrating items exposed to contact with adjacent materials in occupiable floor areas. T-rated assemblies are required where firestop systems are used to protect the following conditions:
 - 1. Penetrations located outside of wall cavities.
 - 2. Penetrations located outside fire-resistive shaft enclosures.
 - 3. Penetrations located in construction containing doors required to have a temperature-rise rating.
 - 4. Penetrating items larger than a 4-inch-diameter nominal pipe or 16 square inch in overall cross-sectional area.
- D. Fire-Resistive Joint Sealants: ASTM E 119 fire-resistance rating, but not less than that equaling or exceeding the fire-resistance rating of the construction in which the joint occurs.
- E. Provide products that do not deteriorate when exposed to traffic, moisture, and physical damage. Do not use or provide products that are not water resistant nor will erode when placed in the following locations
 - 1. Piping penetrations at plumbing and wet-pipe sprinkler systems, use moisture-resistant through-penetration firestop systems.
 - 2. Floor penetrations with annular spaces exceeding 4 inches or more in width and exposed to possible loading and traffic, use firestop systems capable of supporting the floor loads involved either by installing floor plates or by other approved materials.
 - 3. Insulated piping, use through-penetration firestopping systems not requiring removal of insulation.
- F. Firestopping Exposed to View: Follow ASTM E 84 and provide products with flame-spread values of less than 25 and smoke-developed values of less than 450.

1.5 SUBMITTALS

- A. Product data for each type of product specified.
- B. Product Certification: From firestopping manufacturer to indicate that products supplied comply with local regulations controlling use of volatile organic compounds (VOCs) and are nontoxic to building occupants.
- C. Shop Drawings:
 - 1. Detail materials, installation methods, and relationships to adjoining construction for each through-penetration firestop system by product type and each penetrated construction condition.
 - 2. Include firestop design designation from qualified testing and inspecting agency in compliance with firestop requirements.
 - 3. When Project conditions require modification of qualified testing and inspecting agency's illustration to suit a particular through-penetration firestop condition,

submit details approved by firestopping manufacturer's fire protection engineer with modifications indicated.

- D. Product Certificates: Signed by manufacturers of firestopping products certifying that their products comply with specified requirements.
- E. Product Test Reports: Based on tests performed by, a qualified testing and inspecting agency evidencing compliance of firestopping with requirements based on comprehensive testing of current products.
- F. Qualification data for firms and persons specified in article, "Quality Assurance" of this Section to demonstrate capabilities and experience. Include list of completed projects with project names, addresses, telephone numbers and names of Architect and Owner.

1.6 QUALITY ASSURANCE

- A. Fire-Test-Response Characteristics: Comply with following requirements and those specified under article, "System Performance Requirements" of this Section:
 - 1. Firestopping tests are performed by a qualified testing and inspecting agency, UL, Warnock Hersey, or another national agency performing testing and follow-up inspection services for firestop systems and are acceptable to authorities having jurisdiction.
 - 2. Fire-resistive joint sealant systems are identical to those tested for fire-response characteristics meeting ASTM E 119 under conditions where positive furnace pressure differential is at least 0.01 inch of water, as measured 0.78 inch from face exposed to furnace fire.
- B. Fire-rated design designations of through-penetration firestop systems are intended to establish requirements for performance based on conditions that are expected to exist during installation. Changes in conditions and designated systems require the Architect's prior approval.
- C. Installer Qualifications: Engage an Installer with a minimum of 3 years experience who has completed firestopping that is similar in material, design, and extent to that indicated for Project and that has performed successfully on projects of similar size and scope.
- D. Single-Source Responsibility: Obtain through-penetration firestop systems for each type of penetration and construction condition indicated from a single manufacturer.
- E. Provide firestopping products containing no detectable asbestos as determined by the method specified in 40 CFR Part 763, Subpart F, Appendix A, Section 1, "Polarized Light Microscopy."
- F. Coordinating Work: Coordinate construction of openings and penetrations with work of other Sections to ensure designated through-penetration firestop systems are installed to meet specified requirements.

1.7 DELIVERY, STORAGE, AND HANDLING

- A. Deliver products to Project site in original, unopened containers and packaged intact with legible manufacturers' labels identifying product and manufacturer, date of manufacture, lot number, and shelf life. Include qualified testing and inspecting agency's classification marking applicable to Project, curing time, and mixing instructions for multicomponent materials.
- B. Store and handle firestopping materials to prevent their deterioration or damage due to moisture, temperature changes, contaminants, or other causes.

1.8 PROJECT CONDITIONS

- A. Environmental Conditions: Do not install firestopping when ambient or substrate temperatures are outside limits permitted by firestopping manufacturers or when substrates are wet because of rain, frost, condensation, or other causes.
- B. Ventilation: Ventilate firestopping per firestopping manufacturers' instructions by natural means or, where this is inadequate, forced air circulation.

PART 2 - PRODUCTS

2.1 ACCEPTABLE MANUFACTURERS

- A. Subject to compliance with requirements, provide from the following manufacturer's products, one product for each firestopping and fireproofing system in compliance with UL fire rating tests:
 - 1. Endothermic, Latex Sealant:
 - a. Fyre-Shield by Tremco Inc.
 - 2. Endothermic, Latex Compounds:
 - a. Flame-Safe FS500/600 Series by International Protective Coatings Corp.
 - b. Flame-Safe FS900/FST900 Series by International Protective Coatings Corp.
 - 3. Intumescent Latex Sealant:
 - a. Biostop 500 by Bio Fireshield, Inc.
 - b. Metacaulk 950 by the RectorSeal Corporation.
 - c. Fire Barrier CP 25WB+ Caulk by 3M Fire Protection Products.
 - 4. Intumescent Putty:
 - a. Biostop 500 Acrylic Intumescent by Bio Fireshield, Inc.
 - b. Flame-Safe FSP1000 Putty by International Protective Coatings Corp.
 - c. Fire Barrier Moldable Putty by 3M Fire Protection Products.

5. Intumescent Wrap Strips:
 - a. Biostop 500 Acrylic Waterbased Intumescent by Bio Fireshield, Inc.
 - b. Fire Barrier FS-195 Wrap/Strip by 3M Fire Protection Products.
6. Job-Mixed Vinyl Compound:
 - a. USG Firecode Compound by United States Gypsum Co. (USG).
7. Mortar:
 - a. K-2 Firestop Mortar ("pick proof") by Bio Fireshield, Inc.
 - b. Novasit K-10 Firestop Mortar by Bio Fireshield, Inc.
 - c. KBS-Mortar Seal by International Protective Coatings Corp.
8. Silicone Sealants:
 - a. Biotherm 100 and 200, self leveling, gungrade by Bio Fireshield, Inc.
 - b. Metacaulk 835 by The RectorSeal Corporation.
 - c. Metacaulk 880 by The RectorSeal Corporation.
 - d. Fyre-Sil by Tremco Inc.
 - e. Fyre-Sil S/L by Tremco Inc.
9. Solvent-Release-Curing Intumescent Sealants:
 - a. Fire Barrier CP 25N/S Caulk by 3M Fire Protection Products.
 - b. Fire Barrier CP 25S/L Caulk by 3M Fire Protection Products.

2.2 FIRESTOPPING MATERIALS

- A. Compatibility: Provide firestopping composed of components that are compatible with each other, the substrates forming openings, and the items, if any, penetrating the firestopping under conditions of service and application, as demonstrated by firestopping manufacturer based on testing and field experience.
- B. Accessories: Provide UL components for each firestopping system, fill materials, and installation in compliance with article, "System Performance Requirements" of this Section.
 1. Use only components specified by the firestopping manufacturer and approved by the qualified testing and inspecting agency for the designated fire-resistance-rated systems.
 2. Joint Fillers: Fire blocking packing designed specifically for rated wall joints in combinations with rated sealant; "Ultra Block" by Backerrod Manufacturing, 2450 Blake Street, Denver, CO.
 3. Void Packing: 6 pcf mineral wool.
- C. Applications: Provide firestopping systems composed of materials specified in this Section that comply with system performance and other requirements.

2.3 FIRE-RESISTIVE ELASTOMERIC JOINT SEALANT

- A. Elastomeric Sealant Standard: ASTM C 920; manufacturer's standard chemically curing, elastomeric sealants of base polymer, including those referenced for Type, Grade, Class, and Uses, and requirements specified in this Section applicable to fire-resistive joint sealants.
- B. Sealant Colors: Provide color of exposed joint sealants to comply with selections made by Architect from manufacturer's standard colors for products of type indicated.
- C. Multicomponent, Nonsag, Urethane Sealant: ASTM C 719, Type M; Grade NS; Class 25; exposure-related Use NT, and joint-substrate-related uses under maximum cyclic movement that remain in compliance with other requirements of ASTM C 920.
- D. Single-Component, Nonsag, Urethane Sealant: Type S; Grade NS; Class 25; and uses applicable to joint substrates.

2.4 MIXING

- A. Comply with firestopping manufacturer's directions for accurate proportioning of materials, liquids, type of mixing equipment, selection of mixer speeds, mixing containers, mixing time, and other procedures needed to produce firestopping products of uniform quality with optimum performance characteristics for application indicated.

PART 3 - EXECUTION

3.1 EXAMINATION

- A. Examine substrates and conditions, with Installer present, for compliance with requirements for opening configurations, penetrating items, substrates, and other conditions affecting performance of firestopping. Do not proceed with installation until unsatisfactory conditions have been corrected.

3.2 PREPARATION

- A. Surface Cleaning: Clean out openings and joints immediately prior to installing firestopping to comply with recommendations of firestopping manufacturer and the following requirements:
 - 1. Remove foreign materials from surfaces of opening and joint substrates and from penetrating items that may interfere with adhesion of firestopping.
 - 2. Clean opening and joint substrates and penetrating items to produce clean, sound surfaces capable of developing optimum bond with firestopping. Remove loose particles remaining from cleaning operation.
 - 3. Remove laitance and form release agents from concrete.

- B. Priming: Only prime substrates where recommended by firestopping manufacturer using that manufacturer's recommended products and methods. Confine primers to areas of bond; do not allow spillage and migration onto exposed surfaces.
- C. Masking Tape: Use masking tape to prevent firestopping from contacting adjoining surfaces that will remain exposed upon completion of Work and that would otherwise be permanently stained or damaged by such contact or by cleaning methods used to remove smears from firestopping materials. Remove tape as soon as it is possible to do so without disturbing firestopping's seal with substrates.

3.3 INSTALLING THROUGH-PENETRATION FIRESTOPS

- A. General: Comply with article, "System Performance Requirements" of this Section and the through-penetration firestop manufacturer's installation instructions and drawings pertaining to products and applications indicated.
- B. Install forming/damming materials and other accessories of types required to support fill materials during their application and in the position needed to produce the cross-sectional shapes and depths required to achieve fire ratings of designated through-penetration firestop systems. After installing fill materials, remove combustible forming materials and other accessories not indicated as permanent components of firestop systems.
- C. Install fill materials for through-penetration firestop systems by proven techniques to produce the following results:
 - 1. Completely fill voids and cavities formed by openings, forming materials, accessories, and penetrating items.
 - 2. Apply materials so they contact and adhere to substrates formed by openings and penetrating items.
 - 3. For fill materials that will remain exposed after completing Work, finish to produce smooth, uniform surfaces that are flush with adjoining finishes.

3.4 INSTALLING FIRE-RESISTIVE JOINT SEALANTS

- A. General: Comply with Article "System Performance Requirements" of this Section, ASTM C 1193, and with sealant manufacturer's installation instructions and drawings pertaining to products and applications indicated.
- B. Install joint fillers to provide support of sealants during application and at position required to produce the cross-sectional shapes and depths of installed sealants relative to joint widths that allow optimum sealant movement capability and develop fire-resistance rating required.
- C. Install sealants by proven techniques that completely fill recesses provided for each joint configuration, and providing uniform, cross-sectional shapes and depths relative to joint width with optimum sealant movement capability. Install sealants at the same time joint fillers are installed.

- D. Tool nonsag sealants immediately after sealant application and prior to the time skinning or curing begins. Form smooth, uniform beads of configuration indicated or required to produce fire-resistance rating, as well as to eliminate air pockets, and to ensure contact and adhesion of sealants with sides of joint. Remove excess sealant from surfaces adjacent to joint. Do not use tooling agents that discolor sealants or adjacent surfaces or are not approved by sealant manufacturer.

3.5 CLEANING

- A. Clean off excess fill materials and sealants adjacent to openings and joints as work progresses by methods and with cleaning materials approved by manufacturers of firestopping products and of products in which opening and joints occur.
- B. Protect firestopping during and after curing period from contact with contaminating substances or damage resulting from construction operations or other damaging causes until Substantial Completion. If damage or deterioration occurs, cut out and remove damaged or deteriorated firestopping immediately and install new firestopping materials to complying with requirements of this Section.

END OF SECTION 078413

SECTION 079200 - JOINT SEALANTS

PART 1 - GENERAL

1.1 RELATED DOCUMENTS

- A. Drawings and general provisions of the Contract, including General and Supplementary Conditions and other Division 1 Specification Sections, apply to this Section.

1.2 SECTION INCLUDES

- A. Preparing sealant substrate surfaces.
- B. Security grade sealants.
- C. Non-Security grade sealants.
- D. Backing material.

1.3 RELATED SECTIONS

- A. Section 042000 "Unit Masonry" for masonry control and expansion joint Oilers and gaskets
- B. Section 078413 "Penetration Firestopping" for fire-rated fillers and sealants used in fire-rated construction.
- C. Section 111910 "Detention Doors and Frames" for sealants used in conjunction with interior hollow metal frames, interior and exterior door and hollow metal frame perimeters.
- D. Division 23 "HVAC" for sealants used in conjunction with systems and component installation.
- E. Division 22 "Plumbing" for sealants used in conjunction with systems and component installation.
- F. Section 111990 "Security Hollow Metal Panel Wall System" for sealants used in conjunction with systems and component installation.

1.4 PRECONSTRUCTION TESTING

- A. Preconstruction Compatibility and Adhesion Testing: Submit to joint-sealant manufacturers, for testing indicated below, samples of materials that will contact or affect joint sealants.

1. Use ASTM C 1087 to determine whether priming and other specific joint preparation techniques are required to obtain rapid, optimum adhesion of joint sealants to joint substrates.
 2. Submit not fewer than four pieces of each kind of material, including joint substrates, shims, joint-sealant backings, secondary seals, and miscellaneous materials.
 3. Schedule sufficient time for testing and analyzing results to prevent delaying the Work.
 4. For materials failing tests, obtain joint-sealant manufacturer's written instructions for corrective measures including use of specially formulated primers.
 5. Testing will not be required if joint-sealant manufacturers submit joint preparation data that are based on previous testing, not older than 24 months, of sealant products for adhesion to, and compatibility with, joint substrates and other materials matching those submitted.
- B. Preconstruction Field-Adhesion Testing: Before installing sealants, field test their adhesion to Project joint substrates as follows:
1. Locate test joints where indicated on Project or, if not indicated, as directed by Architect.
 2. Conduct field tests for each application indicated below:
 - a. Each kind of sealant and joint substrate indicated.
 3. Notify Architect seven days in advance of dates and times when test joints will be erected.
 4. Arrange for tests to take place with joint-sealant manufacturer's technical representative present.
 - a. Test Method: Test joint sealants according to Method A, Field-Applied Sealant Joint Hand Pull Tab, in Appendix X1 in ASTM C 1193 or Method A, Tail Procedure, in ASTM C 1521.
 - 1) For joints with dissimilar substrates, verify adhesion to each substrate separately; extend cut along one side, verifying adhesion to opposite side. Repeat procedure for opposite side.
 5. Report whether sealant failed to adhere to joint substrates or tore cohesively. Include data on pull distance used to test each kind of product and joint substrate. For sealants that fail adhesively, retest until satisfactory adhesion is obtained.
 6. Evaluation of Preconstruction Field-Adhesion-Test Results: Sealants not evidencing adhesive failure from testing, in absence of other indications of noncompliance with requirements, will be considered satisfactory. Do not use sealants that fail to adhere to joint substrates during testing.

1.5 ACTION SUBMITTALS

- A. Product Data: Manufacturer's printed data indicating sealant chemical characteristics, performance criteria, limitations, color availability, and installation instructions.

B. LEED Submittals:

1. Product Data for Credit IEQ 4.1: For sealants and sealant primers used inside the weatherproofing system, documentation including printed statement of VOC content.
2. Laboratory Test Reports for Credit IEQ 4: For sealants and sealant primers used inside the weatherproofing system, documentation indicating that products comply with the testing and product requirements of the California Department of Health Services' "Standard Practice for the Testing of Volatile Organic Emissions from Various Sources Using Small-Scale Environmental Chambers."

C. Samples for Initial Selection: Manufacturer's color charts consisting of strips of cured sealants showing the full range of colors available for each product exposed to view.

D. Samples for Verification: For each kind and color of joint sealant required, provide Samples with joint sealants in 1/2-inchwide joints formed between two 6-inchlong strips of material matching the appearance of exposed surfaces adjacent to joint sealants.

E. Joint-Sealant Schedule: Include the following information:

1. Joint-sealant application, joint location, and designation.
2. Joint-sealant manufacturer and product name.
3. Joint-sealant formulation.
4. Joint-sealant color.

F. Certificates: Submit manufacturer's certification that products meet or exceed specified requirements and that sealants are compatible with adjoining substrates including security glazing products.

1.6 INFORMATIONAL SUBMITTALS

A. Qualification Data: For qualified Installer and testing agency.

B. Product Certificates: For each kind of joint sealant and accessory, from manufacturer.

C. Sealant, Waterproofing, and Restoration Institute (SWRI) Validation Certificate: For each sealant specified to be validated by SWRI's Sealant Validation Program.

D. Product Test Reports: Based on evaluation of comprehensive tests performed by a qualified testing agency, indicating that sealants comply with requirements.

E. Preconstruction Compatibility and Adhesion Test Reports: From sealant manufacturer, indicating the following:

1. Materials forming joint substrates and joint-sealant backings have been tested for compatibility and adhesion with joint sealants.
2. Interpretation of test results and written recommendations for primers and substrate preparation needed for adhesion.

- F. Preconstruction Field-Adhesion Test Reports: Indicate which sealants and joint preparation methods resulted in optimum adhesion to joint substrates based on testing specified in "Preconstruction Testing" Article.
- G. Field-Adhesion Test Reports: For each sealant application tested.
- H. Warranties: Sample of special warranties.

1.7 QUALITY ASSURANCE

- A. All joints, gaps, spaces and openings caused, created or considered normal under standard construction practices are not acceptable in this facility and must be filled with security or non-security sealants.
- B. Security zones/areas include, but not limited to, all walls, floors, ceilings, structure, equipment, mechanical, electrical, electronic items and furnishings.
 - 1. The security zones/areas define the boundaries where security and non-security sealants are to be provided.
- C. Manufacturer: Company specializing in manufacturing products specified in this Section with a minimum of 10 continuous years of documented experience.
- D. Installer: Company specializing in installation of work in this Section with a minimum 5 continuous years of documented experience and approved by sealant manufacturer.
 - 1. Submit Certification of experience and sealant manufacturer's approval.
- E. Comply with Sealant and Waterproofers Institute requirements for materials and installation.
- F. Product Testing: Test joint sealants using a qualified testing agency.
 - 1. Testing Agency Qualifications: An independent testing agency qualified according to ASTM C 1021 to conduct the testing indicated.
 - 2. Test according to SWRI's Sealant Validation Program for compliance with requirements specified by reference to ASTM C 920 for adhesion and cohesion under cyclic movement, adhesion-in-peel, and indentation hardness.
- G. Mockups: Install sealant in mockups of assemblies specified in other Sections that are indicated to receive joint sealants specified in this Section. Use materials and installation methods specified in this Section.
- H. Preinstallation Conference: Conduct conference at Project site.

1.8 ENVIRONMENTAL REQUIREMENTS

- A. Maintain environmental temperature and humidity recommended by the sealant manufacturer a minimum of 72 hours before, during and after installation.

- B. Do not install sealants when the substrate temperatures and humidity levels are outside the manufacturer's published temperature and humidity requirements.

1.9 WARRANTY

A. Warranty:

1. Provide 5-year warranty for installed sealants and accessories against failure to achieve air tight and watertight seal, exhibit loss of adhesion or cohesion, or will not cure.
2. Warranty period begins on the date established for Substantial Completion.

PART 2 - PRODUCTS

2.1 ACCEPTABLE MANUFACTURERS

- A. Sika Corp., 201 Polita Ave., Lyndhurst, NJ.
- B. Pecora Corp., 165 Wambold Rd., Harleysville, PA.
- C. Tremco, Inc., Beachwood, OH
- D. Rhone-Poulenc, Inc., Plymouth, NJ
- E. General Electric Corp., Waterford, NY

2.2 SEALANTS

A. Type A1:

1. One-component high modulus polyurethane, tamper resistant, non-staining, non-bleeding, capable of continuous water immersion, non-sagging.
2. Elongation Capability:
 - a. ASTM D 412; 300 percent.
3. Service Temperature Range:
 - a. Minus 40 to 170 degrees F.
4. Application Temperature:
 - a. 40 to 95 degrees F.
5. Tack-Free Cure:
 - a. 1 hour.

6. Shore A Hardness:
 - a. ASTM D 2240; 55 after 14 days.
 7. Tensile Strength:
 - a. ASTM D 412; 500 psi after 14 days.
 8. Colors as selected by Architect.
 9. Acceptable Product:
 - a. Sikaflex TR by Sika.
- B. Type A2:
1. Two-component polyurethane, chemical curing, non-staining, non-bleeding, capable of continuous water immersion, non-sagging.
 2. Elongation Capability:
 - a. 175-200 percent.
 3. Service Temperature Range:
 - a. Minus 40 to 180 degrees F.
 4. Shore A Hardness:
 - a. Minimum 55.
 5. Tensile Strength:
 - a. 375 to 400 psi.
 6. Colors as selected by Architect.
 7. Acceptable Product:
 - a. Dynaflex by Pecora.
- C. Type B:
1. Multi-component urethane, chemical curing, non-staining, non-bleeding, capable of continuous water immersion, non-sagging.
 2. Elongation Capability:
 - a. 50 percent.
 3. Service Temperature Range:
 - a. Minus 40 to 180 degrees F.
 4. Shore A Hardness Range:

- a. 20 to 35.
5. Colors as selected Architect.
6. Acceptable Product:
 - a. Dynatrol II by Pecora or
 - b. Sikaflex -2C, NS by Sika.
- D. Type C:
 1. Single-component silicone, high structural strength solvent curing, non-sagging, non-staining, fungus resistant, non-bleeding.
 2. Elongation Capability:
 - a. 25 percent.
 3. Service Temperature Range:
 - a. Minus 65 to 180 degrees F.
 4. Shore A Hardness Range:
 - a. 15 to 35.
 5. Colors as selected Architect.
 6. Acceptable Products:
 - a. No.863 and/or
 - b. No.864 by Pecora.
- E. Type D:
 1. Two-part, cold-applied polyurethane traffic grade, chemically curing, self-leveling, horizontal grade elastomeric sealant.
 2. Colors as selected Architect.
 3. Acceptable Product:
 - a. Urexpenn NR-200 and primer by Pecora.
- F. Type E1:
 1. Security sealant; 2 component, 100% solids, moisture insensitive, high modulus, high strength, structural epoxy, and with "pick-proof" characteristics.
 2. Limitation:
 - a. For joints not wider than 1/4 inch.
 3. Elongation Capability:
 - a. ASTM D 638, 1.3 percent.
 4. Application Temperature Range:

- a. 65 to 85 degrees F.
 5. Shear Strength (14 day):
 - a. ASTM D 732, 3,700 psi.
 6. Color:
 - a. Standard gray.
 7. Acceptable Product:
 - a. Sikadur Injection Gel by Sika Corp.
- G. Type E2:
1. Security grade control joint sealer/adhesive; 2 component, flexible epoxy, solvent free, moisture-insensitive, non-sag type, and with permanent flexibility characteristics.
 2. Limitation:
 - a. For use in non-movement, stable control joints.
 3. Elongation Capability (at break):
 - a. ASTM D 638; 100 percent.
 4. Application Temperature Range:
 - a. 65 to 85 degrees F.
 5. Shear Strength:
 - a. ASTM D 732; 800 psi after 14 days.
 6. Color:
 - a. Concrete gray.
 7. Acceptable Products:
 - a. Sikadur No. 51 NS by Sika Corp or
 - b. Security Sealant EP-1200 by Pecora.
- H. Type E3:
1. Security paste adhesive; 2 component, epoxy, 100% solids, high-modulus, high-strength, and insensitive to moisture.
 2. Limitation:
 - a. For joints not wider than 1/8 inch.

3. Elongation Capability:
 - a. ASTM D 638; 0.4 percent.
4. Application Temperature Range:
 - a. 65 to 85 degrees F.
5. Shear Strength (14 day):
 - a. ASTM D 732, 3,400 psi.
6. Color:
 - a. Concrete gray.
7. Approvals:
 - a. USDA in food plants.
8. Acceptable Product:
 - a. Sikadur No. 31 Hi-Mod Gel by Sika Corp.

I. Type F

1. Acoustical Joint Sealant: Manufacturer's standard nonsag, paintable, nonstaining latex sealant complying with ASTM C 834. Product effectively reduces airborne sound transmission through perimeter joints and openings in building construction as demonstrated by testing representative assemblies according to ASTM E 90.
2. Products: Subject to compliance with requirements, provide one of the following available products that may be incorporated into the Work include, but are not limited to, the following:
 - a. Pecora Corporation; AC-20 FTR or AIS-919.
 - b. USG Corporation; SHEETROCK Acoustical Sealant.

2.3 ACCESSORIES

A. General:

1. Types as recommended by sealant manufacturer, compatible with joint sealing materials, and formulated to suit application.
2. Primer:
 - a. Non-staining type.
3. Joint Cleaner:

- a. Non-corrosive and non-staining type.

- B. Joint Backing:
 - 1. ASTM D 1056, round polyurethane foam rod, and oversized 20 to 30 percent larger than joint width.
 - 2. Interior Applications (non-security):
 - a. Open cell rod; No.91 Denverfoam by Pecora.
 - 3. Interior Security Joints:
 - a. Closed cell rod (with security sealant); "Green Rod" by Pecora.
 - 4. Exterior Applications:
 - a. Closed cell rod; manufactured by Pecora.

- C. Bond Breaker:
 - 1. Pressure sensitive tape recommended by sealant manufacturer to suit application.

PART 3 - EXECUTION

3.1 INSPECTION

- A. Verify that surfaces and joint openings are ready to receive Work and field measurements are as shown on drawings and recommended by the manufacturer.
- B. Beginning of installation means installer accepts existing surfaces.

3.2 PREPARATION

- A. Clean and prime joints in compliance with manufacturer's printed instructions even if priming is indicated in manufacturer's published material as an option.
- B. Remove loose materials and foreign matter that might impair adhesion of sealant.
- C. Verify that joint backing and release tapes are compatible with sealant.
- D. Protect elements surrounding the Work of this Section from damage or disfiguration.

3.3 INSTALLATION

- A. Provide sealant types as scheduled and as indicated.

- B. Provide security sealant Type E-1 at all open joints, cracks and openings not scheduled or identified but within the security zones wherein the thickness of a razor blade can be inserted.
- C. A security zone includes the entire building envelope inclusive of floors, walls, ceilings, structure and installed items within the zone.
- D. Provide the Type E-1 security sealant as directed by the Architect and/or Owner at no additional cost to the Owner.
- E. Provide non-security sealant Type A1 and/or A2 at all joints, cracks and openings not scheduled or identified but outside of the security zones wherein the thickness of a razor blade can be inserted.
- F. Provide the Type A1 and/or Type A2 non-security sealant as directed by the Architect and/or Owner at no additional cost to the Owner.
- G. Install sealant in compliance with manufacturer's published instructions.
- H. Measure joint dimensions and size materials to achieve required width/depth ratios.
- I. Install joint backing to achieve a neck dimension no greater than 1/3 the joint width.
- J. Install bond breaker where joint backing is not required because of insufficient joint depth.
- K. Apply sealant within recommended application temperature ranges.
- L. Consult and obtain written instructions from the manufacturer when sealant cannot be applied within manufacturer's specified temperature ranges.
- M. Install sealant free of air pockets, foreign embedded matter, ridges, and sags.
- N. Tool joints concave, unless otherwise indicated.

3.4 PROTECTION, CLEANING, AND REPAIRING

- A. Clean adjacent soiled surfaces.
- B. Protect sealants until cured.
- C. Repair or replace defaced or disfigured surfaces caused by Work of this Section.

3.5 SEALANT SCHEDULE

Specified Type	Product Type	Installation Location	Re- marks

Specified Type	Product Type	Installation Location	Re- marks
Type A1 & A2	Elastomeric Polyurethane Sealant.	Exposed to view equipment and hardware perimeters.	
Type B	Two part urethane Type II.	Perimeter of exterior windows, door frames, louvers, pipes, light fixtures, conduit and other exterior wall items or elements that are attached to and/or penetrate the exterior perimeter of the building. All exposed to view exterior metal wall panel joints, caps, flashings and adjacent and/or adjoining materials. Perimeter of exterior precast concrete wall panel, including control and expansion joints.	
Type C	One part silicone, clear color.		
Type D	Polyurethane traffic grade.		
Type E1 or E2	Two-part, epoxy "pick-proof" gel.	Perimeter of sliding cell and corridor device housing covers. Perimeter of sliding cell and corridor receiver columns and locking columns.	Note 1
Type E2	Two-part, security epoxy.	Perimeter of detention hollow metal door and window frames, interior. Perimeter of all wall mounted exposed to view mechanical, electrical and electronic items and elements within the facility. Perimeter of all exposed to view ceiling mounted items and elements within the facility when the ceiling height is ten feet or less above the finish floor.	Note 1
Type E3	Two-part, security epoxy.	Perimeter joint of interior precast concrete panels.	Note 1
Type F	Acoustical joint sealant	Edge moldings at perimeters of acoustical tile ceiling	

Remark Notes

Note 1: Do not use these types of security sealants between interior elements of structure that require movement including expansion and contraction, use Sealant Type A1 or A2.

SECTION 081113 – NON-DETENTION HOLLOW METAL DOORS AND FRAMES

PART 1 - GENERAL

1.1 RELATED DOCUMENTS

- A. Drawings and general provisions of the Contract, including General and Supplementary Conditions and Division 01 Specification Sections, apply to this Section.

1.2 SUMMARY

- A. Section Includes:

- 1. Standard hollow metal doors and frames.

- B. Related Sections:

- 1. Division 04 Section "Unit Masonry" for embedding anchors for hollow metalwork into masonry construction.
 - 2. Division 08 Section "Detention Doors and Frames" for hollow metal doors and frames for detention facilities.
 - 3. Division 08 Section "Door Hardware" for door hardware for hollow metal doors.
 - 4. Division 09 Sections "Interior Painting" for field painting hollow metal doors and frames.

1.3 DEFINITIONS

- A. Minimum Thickness: Minimum thickness of base metal without coatings.
- B. Standard Hollow Metal Work: Hollow metalwork fabricated according to ANSI/SDI A250.8.
- C. Custom Hollow Metal Work: Hollow metalwork fabricated according to ANSI/NAAMM-HMMA 861.

1.4 SUBMITTALS

- A. Product Data: For each type of product indicated. Include construction details, material descriptions, core descriptions, fire-resistance rating, temperature-rise ratings, and finishes.
- B. Shop Drawings: Include the following:
 - 1. Elevations of each door design.

2. Details of doors, including vertical and horizontal edge details and metal thicknesses.
 3. Frame details for each frame type, including dimensioned profiles and metal thicknesses.
 4. Locations of reinforcement and preparations for hardware.
 5. Details of each different wall opening condition.
 6. Details of anchorages, joints, field splices, and connections.
 7. Details of accessories.
 8. Details of moldings, removable stops, and glazing.
- C. Samples for Initial Selection: For units with factory-applied color finishes.
- D. Samples for Verification:
1. For each type of exposed finish required, prepared on Samples of not less than 3 by 5 inches.
 2. For the following items, prepared on Samples about 12 by 12 inches to demonstrate compliance with requirements for quality of materials and construction:
 - a. Doors: Show vertical-edge, top, and bottom construction; core construction; and hinge and other applied hardware reinforcement. Include separate section showing glazing if applicable.
 - b. Frames: Show profile, corner joint, floor and wall anchors, and silencers. Include separate section showing fixed hollow metal panels and glazing if applicable.
- E. Other Action Submittals:
1. Schedule: Provide a schedule of hollow metalwork prepared by or under the supervision of supplier, using same reference numbers for details and openings as those on Drawings. Coordinate with door hardware schedule.
- F. Oversize Construction Certification: For assemblies required to be fire rated and exceeding limitations of labeled assemblies.
- G. Product Test Reports: Based on evaluation of comprehensive tests performed by a qualified testing agency, for each type of hollow metal door and frame assembly.
- 1.5 QUALITY ASSURANCE
- A. Source Limitations: Obtain hollow metalwork from single source from single manufacturer.
- B. Fire-Rated Door Assemblies: Assemblies complying with NFPA 80 that are listed and labeled by a qualified testing agency, for fire-protection ratings indicated, based on testing at as close to neutral pressure as possible according to NFPA 252.

1. Where required by agencies having jurisdiction, provide label on door and label on frame.
 2. Oversize Fire-Rated Door Assemblies: For units exceeding sizes of tested assemblies, provide certification by a qualified testing agency that doors comply with standard construction requirements for tested and labeled fire-rated door assemblies except for size.
 3. Temperature-Rise Limit: At vertical exit enclosures and exit passageways, provide doors that have a maximum transmitted temperature end point of not more than 450 deg F above ambient after 30 minutes of standard fire-test exposure.
- C. Fire-Rated, Borrowed-Light Frame Assemblies: Assemblies complying with NFPA 80 that are listed and labeled, by a testing and inspecting agency acceptable to authorities having jurisdiction, for fire-protection ratings indicated, based on testing according to NFPA 257 or UL 9. Label each individual glazed lite.
- D. Smoke-Control Door Assemblies: Comply with NFPA 105 or UL 1784.
- E. Preinstallation Conference: Conduct conference at Project site.

1.6 DELIVERY, STORAGE, AND HANDLING

- A. Deliver hollow metalwork palletized, wrapped, or crated to provide protection during transit and Project-site storage. Do not use nonvented plastic.
1. Provide additional protection to prevent damage to finish of factory-finished units.
- B. Deliver welded frames with two removable spreader bars across bottom of frames, tack welded to jambs and mullions.
- C. Store hollow metal work under cover at Project site. Place in stacks of five units maximum in a vertical position with heads up, spaced by blocking, on minimum 4-inch-high wood blocking. Do not store in a manner that traps excess humidity.
1. Provide minimum 1/4-inch space between each stacked door to permit air circulation.

1.7 PROJECT CONDITIONS

- A. Field Measurements: Verify actual dimensions of openings by field measurements before fabrication.

1.8 COORDINATION

- A. Coordinate installation of anchorages for hollow metal frames. Furnish setting drawings, templates, and directions for installing anchorages, including sleeves, concrete inserts, anchor bolts, and items with integral anchors. Deliver such items to Project site in time for installation.

PART 2 - PRODUCTS

2.1 MANUFACTURERS

- A. Manufacturers: Subject to compliance with requirements, provide products by one of the following available manufacturers offering products that may be incorporated into the Work include, but are not limited to, the following:
1. Curries Company; an Assa Abloy Group company.
 2. Firedoor Corporation.
 3. Habersham Metal Products Company
 4. Security Metal Products Corp.
 5. Steelcraft; an Ingersoll-Rand company.
 6. Trussbilt, LLC.

2.2 MATERIALS

- A. Cold-Rolled Steel Sheet: ASTM A 1008/A 1008M, Commercial Steel (CS), Type B; suitable for exposed applications.
- B. Hot-Rolled Steel Sheet: ASTM A 1011/A 1011M, Commercial Steel (CS), Type B; free of scale, pitting, or surface defects; pickled and oiled.
- C. Metallic-Coated Steel Sheet: ASTM A 653/A 653M, Commercial Steel (CS), Type B; with minimum G60 coating.
- D. Frame Anchors: ASTM A 591/A 591M, Commercial Steel (CS), 40Zcoating designation; mill phosphatized.
1. For anchors built into exterior walls, steel sheet complying with ASTM A 1008/A 1008M or ASTM A 1011/A 1011M, hot-dip galvanized according to ASTM A 153/A 153M, Class B.
- E. Inserts, Bolts, and Fasteners: Hot-dip galvanized according to ASTM A 153/A 153M.
- F. Powder-Actuated Fasteners in Concrete: Fastener system of type suitable for application indicated, fabricated from corrosion-resistant materials, with clips or other accessory devices for attaching hollow metal frames of type indicated.
- G. Grout: ASTM C 476, except with a maximum slump of 4 inches, as measured according to ASTM C 143/C 143M.
- H. Mineral-Fiber Insulation: ASTM C 665, Type I (blankets without membrane facing); consisting of fibers manufactured from slag or rock wool with 6- to 12-lb/cu. ft. density; with maximum flame-spread and smoke-development indexes of 25 and 50, respectively; passing ASTM E 136 for combustion characteristics.

- I. Bituminous Coating: Cold-applied asphalt mastic, SSPC-Paint 12, compounded for 15-mildry film thickness per coat. Provide inert-type noncorrosive compound free of asbestos fibers, sulfur components, and other deleterious impurities.

2.3 STANDARD HOLLOW METAL DOORS

- A. General: Provide doors of design indicated, not less than thickness indicated; fabricated with smooth surfaces, without visible joints or seams on exposed faces unless otherwise indicated. Comply with ANSI/SDI A250.8.
 1. Design: Flush panel.
 2. Core Construction: Manufacturer's standard kraft-paper honeycomb, polystyrene, polyurethane, polyisocyanurate, mineral-board, or vertical steel-stiffener core.
 - a. Fire Door Core: As required to provide fire-protection and temperature-rise ratings indicated.
 - b. Thermal-Rated (Insulated) Doors: Where indicated, provide doors fabricated with thermal-resistance value (R-value) of not less than 6.0 deg F x h x sq. ft./Btu when tested according to ASTM C 1363.
 - 1) Locations: Exterior doors and interior doors where indicated.
 3. Vertical Edges for Single-Acting Doors: Square edge.
 4. Top and Bottom Edges: Closed with flush or inverted 0.042-inchthick, end closures, or channels of same material as face sheets.
 5. Tolerances: Comply with SDI 117, "Manufacturing Tolerances for Standard Steel Doors and Frames."
- B. Exterior Doors: Face sheets fabricated from metallic-coated steel sheet. Provide doors complying with requirements indicated below by referencing ANSI/SDI A250.8 for level and model and ANSI/SDI A250.4 for physical performance level:
 1. Level 2 and Physical Performance Level B (Heavy Duty), Model 1 Full Flush.
- C. Interior Doors: Face sheets fabricated from cold-rolled steel sheet. Provide doors complying with requirements indicated below by referencing ANSI/SDI A250.8 for level and model and ANSI/SDI A250.4 for physical performance level:
 1. Level 2 and Physical Performance Level B (Heavy Duty), Model 1 Full Flush.
 - a. Width: 1-3/4 inches.
- D. Hardware Reinforcement: Fabricate according to ANSI/SDI A250.6 with reinforcing plates from same material as door face sheets.
- E. Fabricate concealed stiffeners and hardware reinforcement from either cold- or hot-rolled steel sheet.

2.4 STANDARD HOLLOW METAL FRAMES

- A. General: Comply with ANSI/SDI A250.8 and with details indicated for type and profile.
- B. Exterior Frames: Fabricated from metallic-coated steel sheet.
 - 1. Fabricate frames with mitered or coped corners.
 - 2. Fabricate frames as face welded unless otherwise indicated.
 - 3. Frames for Level 2 Steel Doors: 0.053-inch-thick steel sheet.
- C. Interior Frames: Fabricated from cold-rolled steel sheet.
 - 1. Fabricate frames with mitered or coped corners.
 - 2. Fabricate frames as face welded unless otherwise indicated.
 - 3. Fabricate knocked-down, drywall slip-on frames for in-place gypsum board partitions.
 - 4. Frames for Level 2 Steel Doors: 0.053-inch-thick steel sheet.
 - 5. Frames for Borrowed Lights 0.053-inch-thick steel sheet thick steel sheet.
- D. Hardware Reinforcement: Fabricate according to ANSI/SDI A250.6 with reinforcement plates from same material as frames.

2.5 CUSTOM HOLLOW METAL DOORS

- A. General: Provide doors not less than 1-3/4 inches thick, of seamless hollow construction unless otherwise indicated. Construct doors with smooth surfaces without visible joints or seams on exposed faces. Comply with ANSI/NAAMM-HMMA 861.
- B. Exterior Door Face Sheets: Fabricated from metallic-coated steel sheet, minimum 0.053 inch thick.
- C. Interior Door Face Sheets: Fabricated from cold-rolled steel sheet, minimum 0.042 inch thick.
- D. Core Construction: Provide thermal-resistance-rated cores for exterior doors.
 - 1. Steel-Stiffened Core: 0.026-inch-thick, steel vertical stiffeners of same material as face sheets extending full-door height, with vertical webs spaced not more than 6 inches apart, spot-welded to face sheets a maximum of 5 inches o.c. Spaces filled between stiffeners with glass- or mineral-fiber insulation.
 - a. Fire Door Core: As required to provide fire-protection and temperature-rise ratings indicated.
 - b. Thermal-Rated (Insulated) Doors: Where indicated, provide doors fabricated with thermal-resistance value (R-value) of not less than 4.0 deg F x h x sq. ft./Btu when tested according to ASTM C 1363.
- E. Hardware Reinforcement: Fabricate according to ANSI/NAAMM-HMMA 861 with reinforcing plates from same material as door face sheets.

2.6 CUSTOM HOLLOW METAL FRAMES

- A. General: Fabricate frames of construction indicated. Close contact edges of corner joints tight with faces mitered and stops butted or mitered. Continuously weld faces and soffits and finish faces smooth. Comply with ANSI/NAAMM-HMMA 861.
- B. Exterior Frames: Formed from metallic-coated steel sheet.
- C. Interior Frames: Fabricated from cold-rolled steel sheet.
- D. Hardware Reinforcement: Fabricate according to ANSI/NAAMM-HMMA 861 with reinforcing plates from same material as frame.

2.7 FRAME ANCHORS

- A. Jamb Anchors:
 - 1. Masonry Type: Adjustable strap-and-stirrup or T-shaped anchors to suit frame size, not less than 0.042 inch thick, with corrugated or perforated straps not less than 2 inches wide by 10 inches long; or wire anchors not less than 0.177 inch thick.
 - 2. Compression Type for Security Hollow Metal Panel Slip-on Frames: Adjustable compression anchors.
- B. Floor Anchors: Formed from same material as frames, not less than 0.042 inch thick, and as follows:
 - 1. Monolithic Concrete Slabs: Clip-type anchors, with two holes to receive fasteners.
 - 2. Separate Topping Concrete Slabs: Adjustable-type anchors with extension clips, allowing not less than 2-inch height adjustment. Terminate bottom of frames at finish floor surface.

2.8 STOPS AND MOLDINGS

- A. Fixed Frame Moldings: Formed integral with hollow metal frames, a minimum of 5/8 inch high unless otherwise indicated.
- B. Terminated Stops: Where indicated on interior door frames, terminate stops 6 inches above finish floor with a 90-degree angle cut, and close open end of stop with steel sheet closure. Cover opening in extension of frame with welded-steel filler plate, with welds ground smooth and flush with frame.
 - 1. Provide terminated stops where indicated.

2.9 ACCESSORIES

- A. Mullions and Transom Bars: Join to adjacent members by welding or rigid mechanical anchors.

- B. Ceiling Struts: Minimum 1/4-inch-thick by 1-inch-wide steel.
- C. Grout Guards: Formed from same material as frames, not less than 0.016 inch thick.

2.10 FABRICATION

- A. Fabricate hollow metalwork to be rigid and free of defects, warp, or buckle. Accurately form metal to required sizes and profiles, with minimum radius for thickness of metal. Where practical, fit and assemble units in manufacturer's plant. To ensure proper assembly at Project site, clearly identify work that cannot be permanently factory assembled before shipment.
- B. Tolerances: Fabricate hollow metalwork to tolerances indicated in ANSI/NAAMM-HMMA 861.
- C. Hollow Metal Doors:
 - 1. Exterior Doors: Provide weep-hole openings in bottom of exterior doors to permit moisture to escape. Seal joints in top edges of doors against water penetration.
 - 2. Astragals: Provide overlapping astragal on one leaf of pairs of doors where required by NFPA 80 for fire-performance rating or where indicated. Extend minimum 3/4 inch beyond edge of door on which astragal is mounted.
- D. Hollow Metal Frames: Where frames are fabricated in sections due to shipping or handling limitations, provide alignment plates or angles at each joint, fabricated of same thickness metal as frames.
 - 1. Welded Frames: Weld flush face joints continuously; grind, fill, dress, and make smooth, flush, and invisible.
 - 2. Transom Bar Frames: Provide closed tubular members with no visible face seams or joints, fabricated from same material as door frame. Fasten members at crossings and to jambs by butt welding.
 - 3. Provide countersunk, flat- or oval-head exposed screws and bolts for exposed fasteners unless otherwise indicated.
 - 4. Grout Guards: Weld guards to frame at back of hardware mortises in frames to be grouted.
 - 5. Floor Anchors: Weld anchors to bottom of jambs and mullions with at least four spot welds per anchor.
 - 6. Jamb Anchors: Provide number and spacing of anchors as follows:
 - a. Masonry Type: Locate anchors not more than 18 inches from top and bottom of frame. Space anchors not more than 32 inches o.c. and as follows:
 - 1) Two anchors per jamb up to 60 inches high.
 - 2) Three anchors per jamb from 60 to 90 inches high.
 - 3) Four anchors per jamb from 90 to 120 inches high.
 - 4) Four anchors per jamb plus 1 additional anchor per jamb for each 24 inches or fraction thereof above 120 inches high.

- b. Compression Type: Not less than two anchors in each jamb.
- 7. Door Silencers: Except on weather-stripped doors, drill stops to receive door silencers as follows. Keep holes clear during construction.
 - a. Single-Door Frames: Drill stop in strike jamb to receive three door silencers.
- E. Fabricate concealed stiffeners, edge channels, and hardware reinforcement from either cold- or hot-rolled steel sheet.
- F. Hardware Preparation: Factory prepare hollow metal work to receive templated mortised hardware; include cutouts, reinforcement, mortising, drilling, and tapping according to the Door Hardware Schedule and templates furnished as specified in Division 08 Section "Door Hardware."
 - 1. Locate hardware as indicated, or if not indicated, according to ANSI/SDI A250.8 or ANSI/NAAMM-HMMA 861.
 - 2. Reinforce doors and frames to receive nontemplated, mortised and surface-mounted door hardware.
 - 3. Comply with applicable requirements in ANSI/SDI A250.6 and ANSI/DHI A115 Series specifications for preparation of hollow metalwork for hardware.
- G. Stops and Moldings: Form corners of stops and moldings with butted or mitered hairline joints.
 - 1. Provide fixed frame moldings on outside of exterior and on secure side of interior doors and frames.
 - 2. Provide loose stops and moldings on inside of hollow metal work.

2.11 STEEL FINISHES

- A. Prime Finish: Apply manufacturer's standard primer immediately after cleaning and pretreating.
 - 1. Shop Primer: Manufacturer's standard, fast-curing, lead- and chromate-free primer complying with ANSI/SDI A250.10 acceptance criteria; recommended by primer manufacturer for substrate; compatible with substrate and field-applied coatings despite prolonged exposure.

PART 3 - EXECUTION

3.1 EXAMINATION

- A. Examine substrates, areas, and conditions, with Installer present, for compliance with requirements for installation tolerances and other conditions affecting performance of the Work.

- B. Examine roughing-in for embedded and built-in anchors to verify actual locations before frame installation.
- C. For the record, prepare written report, endorsed by Installer, listing conditions detrimental to performance of the Work.
- D. Proceed with installation only after unsatisfactory conditions have been corrected.

3.2 PREPARATION

- A. Remove welded-in shipping spreaders installed at factory. Restore exposed finish by grinding, filling, and dressing, as required to make repaired area smooth, flush, and invisible on exposed faces.
- B. Prior to installation, adjust and securely brace welded hollow metal frames for squareness, alignment and plumbness to the following tolerances:
- C. Squareness: Plus or minus 1/16 inch, measured at door rabbet on a line 90 degrees from jamb perpendicular to frame head.
- D. Alignment: Plus or minus 1/16 inch, measured at jambs on a horizontal line parallel to frame head.
- E. Twist: Plus or minus 1/16 inch, measured at opposite face corners of jambs on parallel lines, and perpendicular to plane of wall.
- F. Plumbness: Plus or minus 1/16 inch, measured at jambs on a perpendicular line from head to floor.
- G. Drill and tap doors and frames to receive nontemplated, mortised, and surface-mounted door hardware.

3.3 INSTALLATION

- A. General: Install hollow metalwork plumb, rigid, properly aligned, and securely fastened in place; comply with Drawings and manufacturer's written instructions.
- B. Hollow Metal Frames: Install hollow metal frames of size and profile indicated. Comply with ANSI/SDI A250.11.
 - 1. Set frames accurately in position, plumbed, aligned, and braced securely until permanent anchors are set. After wall construction is complete, remove temporary braces, leaving surfaces smooth and undamaged.
 - a. At fire-protection-rated openings, install frames according to NFPA 80.
 - b. Where frames are fabricated in sections because of shipping or handling limitations, field splice at approved locations by welding face joint continuously; grind, fill, dress, and make splice smooth, flush, and invisible on exposed faces.

- c. Install door silencers in frames before grouting.
 - d. Remove temporary braces necessary for installation only after frames have been properly set and secured.
 - e. Check plumbness, squareness, and twist of frames as walls are constructed. Shim as necessary to comply with installation tolerances.
 - f. Field apply bituminous coating to backs of frames that are filled with grout containing antifreezing agents.
2. Floor Anchors: Provide floor anchors for each jamb and mullion that extends to floor, and secure with postinstalled expansion anchors.
 - a. Floor anchors may be set with powder-actuated fasteners instead of postinstalled expansion anchors if so indicated and approved on Shop Drawings.
3. Metal-Stud Partitions: Solidly pack mineral-fiber insulation behind frames.
 4. Masonry Walls: Coordinate installation of frames to allow for solidly filling space between frames and masonry with grout.
 5. Concrete Walls: Solidly fill space between frames and concrete with grout. Take precautions, including bracing frames, to ensure that frames are not deformed or damaged by grout forces.
 6. In-Place Concrete or Masonry Construction: Secure frames in place with postinstalled expansion anchors. Countersink anchors, and fill and make smooth, flush, and invisible on exposed faces.
 7. In-Place Gypsum Board Partitions: Secure frames in place with postinstalled expansion anchors through floor anchors at each jamb. Countersink anchors, and fill and make smooth, flush, and invisible on exposed faces.
 8. Ceiling Struts: Extend struts vertically from top of frame at each jamb to overhead structural supports or substrates above frame unless frame is anchored to masonry or to other structural support at each jamb. Bend top of struts to provide flush contact for securing to supporting construction. Provide adjustable wedged or bolted anchorage to frame jamb members.
 9. Installation Tolerances: Adjust hollow metal door frames for squareness, alignment, twist, and plumb to the following tolerances:
 - a. Squareness: Plus or minus 1/16 inch, measured at door rabbet on a line 90 degrees from jamb perpendicular to frame head.
 - b. Alignment: Plus or minus 1/16 inch, measured at jambs on a horizontal line parallel to plane of wall.
 - c. Twist: Plus or minus 1/16 inch, measured at opposite face corners of jambs on parallel lines, and perpendicular to plane of wall.
 - d. Plumbness: Plus or minus 1/16 inch, measured at jambs at floor.
- C. Hollow Metal Doors: Fit hollow metal doors accurately in frames, within clearances specified below. Shim as necessary.
1. Non-Fire-Rated Standard Steel Doors:
 - a. Jambs and Head: 1/8 inch plus or minus 1/16 inch.
 - b. Between Edges of Pairs of Doors: 1/8 inch plus or minus 1/16 inch.
 - c. Between Bottom of Door and Top of Threshold: Maximum 3/8 inch.

- d. Between Bottom of Door and Top of Finish Floor (No Threshold):
Maximum 3/4 inch.
2. Fire-Rated Doors: Install doors with clearances according to NFPA 80.
3. Smoke-Control Doors: Install doors according to NFPA 105.

3.4 ADJUSTING AND CLEANING

- A. Final Adjustments: Check and readjust operating hardware items immediately before final inspection. Leave work in complete and proper operating condition. Remove and replace defective work, including hollow metalwork that is warped, bowed, or otherwise unacceptable.
- B. Remove grout and other bonding material from hollow metalwork immediately after installation.
- C. Prime-Coat Touchup: Immediately after erection, sand smooth rusted or damaged areas of prime coat and apply touchup of compatible air-drying, rust-inhibitive primer.
- D. Metallic-Coated Surfaces: Clean abraded areas and repair with galvanizing repair paint according to manufacturer's written instructions.

END OF SECTION 081113

SECTION 087111 - DOOR HARDWARE

PART 1 - GENERAL

1.1 RELATED DOCUMENTS

- A. Drawings and general provisions of the Contract, including General and Supplementary Conditions and Division 01 Specification Sections, apply to this Section.

1.2 SUMMARY

- A. Section includes:
 - 1. Mechanical door hardware for the following:
 - a. Swinging doors.
 - 2. Cylinders for door hardware specified in other Sections.
- B. Related Sections:
 - 1. Division 08 Section "Hollow Metal Doors and Frames" for astragals provided as part of labeled fire-rated assemblies and for door silencers provided as part of hollow-metal frames.

1.3 SUBMITTALS

- A. Product Data: For each type of product indicated. Include construction and installation details, material descriptions, dimensions of individual components and profiles, and finishes.
- B. Samples for Initial Selection: For plastic protective trim units in each finish, color, and texture required for each type of trim unit indicated.
- C. Samples for Verification: For exposed door hardware of each type required, in each finish specified, prepared on Samples of size indicated below. Tag Samples with full description for coordination with the door hardware schedule. Submit Samples before, or concurrent with, submission of door hardware schedule.
 - 1. Sample Size: Full-size units or minimum 2-by-4-inch Samples for sheet and 4-inch long Samples for other products.
 - a. Full-size Samples will be returned to Contractor. Units that are acceptable and remain undamaged through submittal, review, and field comparison process may, after final check of operation, be incorporated into the Work, within limitations of keying requirements.

D. Other Action Submittals:

1. Door Hardware Schedule: Prepared by or under the supervision of Installer, detailing fabrication and assembly of door hardware, as well as installation procedures and diagrams. Coordinate final door hardware schedule with doors, frames, and related work to ensure proper size, thickness, hand, function, and finish of door hardware.
 - a. Submittal Sequence: Submit door hardware schedule concurrent with submissions of Product Data, Samples, and Shop Drawings. Coordinate submission of door hardware schedule with scheduling requirements of other work to facilitate the fabrication of other work that is critical in Project construction schedule.
 - b. Format: Comply with scheduling sequence and vertical format in DHI's "Sequence and Format for the Hardware Schedule." Double space entries, and number and date each page.
 - c. Format: Use same scheduling sequence and format and use same door numbers as in the Contract Documents.
 - d. Content: Include the following information:
 - 1) Identification number, location, hand, fire rating, size, and material of each door and frame.
 - 2) Locations of each door hardware set, cross-referenced to Drawings on floor plans and to door and frame schedule.
 - 3) Complete designations, including name and manufacturer, type, style, function, size, quantity, function, and finish of each door hardware product.
 - 4) Fastenings and other pertinent information.
 - 5) Explanation of abbreviations, symbols, and codes contained in schedule.
 - 6) Mounting locations for door hardware.
 - 7) List of related door devices specified in other Sections for each door and frame.
2. Keying Schedule: Prepared by or under the supervision of Installer, detailing Owner's final keying instructions for locks. Include schematic keying diagram and index each key set to unique door designations that are coordinated with the Contract Documents.

E. Qualification Data: For Architectural Hardware Consultant.

F. Product Test Reports: For compliance with accessibility requirements, based on evaluation of comprehensive tests performed by manufacturer and witnessed by a qualified testing agency, for door hardware on doors located in accessible routes.

G. Maintenance Data: For each type of door hardware to include in maintenance manuals. Include final hardware and keying schedule.

H. Warranty: Special warranty specified in this Section.

1.4 QUALITY ASSURANCE

- A. Installer Qualifications: Supplier of products and an employer of workers trained and approved by product manufacturers and an Architectural Hardware Consultant who is available during the course of the Work to consult with Contractor, Architect, and Owner about door hardware and keying.
 - 1. Warehousing Facilities: In Project's vicinity.
 - 2. Scheduling Responsibility: Preparation of door hardware and keying schedules.
- B. Source Limitations: Obtain each type of door hardware from a single manufacturer.
- C. Fire-Rated Door Assemblies: Where fire-rated door assemblies are indicated, provide door hardware rated for use in assemblies complying with NFPA 80 that are listed and labeled by a qualified testing agency, for fire-protection ratings indicated, based on testing at positive pressure according to NFPA 252 or UL 10C, unless otherwise indicated.
- D. Smoke- and Draft-Control Door Assemblies: Where smoke- and draft-control door assemblies are required, provide door hardware that meets requirements of assemblies tested according to UL 1784 and installed in compliance with NFPA 105.
 - 1. Air Leakage Rate: Maximum air leakage of 0.3 cfm/sq. ft. at the tested pressure differential of 0.3-inch wg of water.
- E. Means of Egress Doors: Latches do not require more than 15 lbf to release the latch. Locks do not require use of a key, tool, or special knowledge for operation.
- F. Accessibility Requirements: For door hardware on doors in an accessible route, comply with the U.S. Architectural & Transportation Barriers Compliance Board's ADA-ABA Accessibility Guidelines ICC/ANSI A117.1.
 - 1. Provide operating devices that do not require tight grasping, pinching, or twisting of the wrist and that operate with a force of not more than 5 lbf.
 - 2. Comply with the following maximum opening-force requirements:
 - a. Interior, Non-Fire-Rated Hinged Doors: 5 lbf applied perpendicular to door.
 - b. Sliding or Folding Doors: 5 lbf applied parallel to door at latch.
 - c. Fire Doors: Minimum opening force allowable by authorities having jurisdiction.
 - 3. Bevel raised thresholds with a slope of not more than 1:2. Provide thresholds not more than 1/2 inch high and 3/4 inch high for exterior sliding doors.
 - 4. Adjust door closer sweep periods so that, from an open position of 70 degrees, the door will take at least 3 seconds to move to a point 3 inches from the latch, measured to the leading edge of the door.
- G. Keying Conference: Conduct conference at Project site to comply with requirements in Division 01 Section "Project Management and Coordination." In addition to Owner, Contractor, and Architect, conference participants shall also include Installer's Architectural Hardware Consultant. Incorporate keying conference decisions into final

keying schedule after reviewing door hardware keying system including, but not limited to, the following:

1. Function of building, flow of traffic, purpose of each area, degree of security required, and plans for future expansion.
2. Preliminary key system schematic diagram.
3. Requirements for key control system.
4. Requirements for access control.
5. Address for delivery of keys.

H. Preinstallation Conference: Conduct conference at Project site.

1. Review and finalize construction schedule and verify availability of materials, Installer's personnel, equipment, and facilities needed to make progress and avoid delays.
2. Inspect and discuss preparatory work performed by other trades.
3. Review required testing, inspecting, and certifying procedures.

1.5 DELIVERY, STORAGE, AND HANDLING

- A. Inventory door hardware on receipt and provide secure lock-up for door hardware delivered to Project site.
- B. Tag each item or package separately with identification coordinated with the final door hardware schedule, and include installation instructions, templates, and necessary fasteners with each item or package.
- C. Deliver keys to manufacturer of key control system for subsequent delivery to Owner.
- D. Deliver keys and permanent cores to Owner by registered mail or overnight package service.

1.6 COORDINATION

- A. Coordinate layout and installation of floor-recessed door hardware with floor construction. Cast anchoring inserts into concrete. Concrete, reinforcement, and formwork requirements are specified in Division 03.
- B. Installation Templates: Distribute for doors, frames, and other work specified to be factory prepared. Check Shop Drawings of other work to confirm that adequate provisions are made for locating and installing door hardware to comply with indicated requirements.
- C. Security: Coordinate installation of door hardware, keying, and access control with Owner's security consultant.
- D. Existing Openings: Where hardware components are scheduled for application to existing construction or where modifications to existing door hardware are required,

field verify existing conditions and coordinate installation of door hardware to suit opening conditions and to provide proper door operation.

1.7 WARRANTY

- A. Special Warranty: Manufacturer's standard form in which manufacturer agrees to repair or replace components of door hardware that fail in materials or workmanship within specified warranty period.
1. Failures include, but are not limited to, the following:
 - a. Structural failures including excessive deflection, cracking, or breakage.
 - b. Faulty operation of doors and door hardware.
 - c. Deterioration of metals, metal finishes, and other materials beyond normal weathering and use.
 2. Warranty Period: Three years from date of Substantial Completion, unless otherwise indicated.
 - a. Exit Devices: Two years from date of Substantial Completion.
 - b. Manual Closers: 10 years from date of Substantial Completion.

1.8 MAINTENANCE SERVICE

- A. Maintenance Tools and Instructions: Furnish a complete set of specialized tools and maintenance instructions for Owner's continued adjustment, maintenance, and removal and replacement of door hardware.
- B. Maintenance Service: Beginning at Substantial Completion, provide six months' full maintenance by skilled employees of door hardware Installer. Include quarterly preventive maintenance, repair or replacement of worn or defective components, lubrication, cleaning, and adjusting as required for proper door and door hardware operation. Provide parts and supplies that are the same as those used in the manufacture and installation of original products.

1.9 EXTRA MATERIALS

- A. Furnish extra materials that match products installed and that are packaged with protective covering for storage and identified with labels describing contents.
1. Door Hardware: Provide two locks of each hand specified. Provide two closers of each type specified.

PART 2 - PRODUCTS

2.1 SCHEDULED DOOR HARDWARE

- A. Provide door hardware for each door as scheduled in Part 3 "Door Hardware Schedule" to comply with requirements in this Section.
 - 1. Door Hardware Sets: Provide quantity, item, size, finish or color indicated.
- B. Designations: Requirements for design, grade, function, finish, size, and other distinctive qualities of each type of door hardware are indicated in Part 3 "Door Hardware Schedule" Article. Products are identified by descriptive titles corresponding to requirements specified in Part 2.

2.2 HINGES

- A. Hinges: BHMA A156.1. Provide template-produced hinges for hinges installed on hollow-metal doors and hollow-metal frames.
 - 1. Manufacturers: Subject to compliance with requirements, provide products by one of the following:
 - a. Baldwin Hardware Corporation.
 - b. Bommer Industries, Inc.
 - c. Cal-Royal Products, Inc.
 - d. Hager Companies.
 - e. IVES Hardware; an Ingersoll-Rand company.
 - f. Lawrence Hardware Inc.
 - g. McKinney Products Company; an ASSA ABLOY Group company.
 - h. PBB, Inc.
 - i. Stanley Commercial Hardware; Div. of The Stanley Works.
- B. Antifriction-Bearing Hinges:
 - 1. Mounting: Full mortise (butts).
 - 2. Bearing Material: Ball bearing.
 - 3. Grade: Grade 1 (heavy weight).
 - 4. Base and Pin Metal:
 - a. Exterior Hinges: Stainless steel with stainless-steel pin.
 - b. Interior Hinges: Brass with stainless-steel pin body and brass protruding heads.
 - c. Hinges for Fire-Rated Assemblies: Stainless steel with stainless-steel pin.
 - 5. Pins: Non-rising loose unless otherwise indicated Nonremovable.
 - a. Outswinging Exterior Doors: Nonremovable.
 - b. Outswinging Corridor Doors with Locks: Nonremovable.

6. Tips: Flat button.
7. Corners: Square 5/32-inch.

C. Plain-Bearing Hinges: Grade 3 (standard weight).

1. Mounting: Full mortise (butts).
2. Base and Pin Metal: Brass with stainless-steel pin body.
3. Pins: Non-rising loose unless otherwise indicated Nonremovable.
 - a. Outswinging Corridor Doors with Locks: Nonremovable.
4. Tips: Flat button.
5. Corners: Square 5/32-inch.

2.3 CENTER-HUNG AND OFFSET PIVOTS

A. Center-Hung and Offset Pivots: BHMA A156.4.

1. Manufacturers: Subject to compliance with requirements, provide products by one of the following:
 - a. DORMA Architectural Hardware; Member of The DORMA Group North America.
 - b. IVES Hardware; an Ingersoll-Rand company.
 - c. Rixson Specialty Door Controls; an ASSA ABLOY Group company.

B. Center-Hung Pivot Sets: Grade 1.

1. Top Pivots: Walking-beam type with retractable pin and oil-impregnated bronze bearing; mortised into door and frame.
2. Bottom Pivots: Recessed in floor in cement case.
3. Base Metal: Bronze.

C. Offset Pivot Sets: Grade 1.

1. Offset: 3/4 inch.
2. Top Pivot: Full-mortise mounting; walking-beam type with retractable pin and oil-impregnated bronze bearing.
 - a. Knuckle: Standard.
 - b. Option: With screw holes designed to straddle lead in the center of lead-lined door.
3. Bottom Pivot: Recessed in floor in cement case.
4. Base Metal: Stainless steel.

2.4 MECHANICAL LOCKS AND LATCHES

A. Lock Functions: As indicated in door hardware schedule.

- B. Lock Throw: Comply with testing requirements for length of bolts required for labeled fire doors, and as follows:
 - 1. Bored Locks: Minimum 1/2-inch latchbolt throw.
 - 2. Mortise Locks: Minimum 3/4-inch latchbolt throw.
 - 3. Deadbolts: Minimum 1-inch.
- C. Lock Backset: 2-3/4 inches, unless otherwise indicated.
- D. Lock Trim:
 - 1. Description: As indicated on Drawings.
 - 2. Levers: Forged.
 - 3. Escutcheons (Roses): Wrought.
 - 4. Dummy Trim: Match lever lock trim and escutcheons.
 - 5. Operating Device: Lever with escutcheons (roses).
- E. Strikes: Provide manufacturer's standard strike for each lock bolt or latchbolt complying with requirements indicated for applicable lock or latch and with strike box and curved lip extended to protect frame; finished to match lock or latch.
 - 1. Flat-Lip Strikes: For locks with three-piece antifriction latchbolts, as recommended by manufacturer.
 - 2. Extra-Long-Lip Strikes: For locks used on frames with applied wood casing trim.
 - 3. Aluminum-Frame Strike Box: Manufacturer's special strike box fabricated for aluminum framing.
 - 4. Rabbet Front and Strike: Provide on locksets for rabbeted meeting stiles.
- F. Mortise Locks: BHMA A156.13; Security Grade 1; stamped steel case with steel or brass parts; Series 1000.
 - 1. Manufacturers: Subject to compliance with requirements, provide products by one of the following:
 - a. Accurate Lock & Hardware Co.
 - b. Adams Rite Manufacturing Co.; an ASSA ABLOY Group company.
 - c. Arrow USA; an ASSA ABLOY Group company.
 - d. Best Access Systems; Div. of Stanley Security Solutions, Inc.
 - e. Cal-Royal Products, Inc.
 - f. Corbin Russwin Architectural Hardware; an ASSA ABLOY Group company.
 - g. Falcon Lock; an Ingersoll-Rand company.
 - h. Marks USA.
 - i. SARGENT Manufacturing Company; an ASSA ABLOY Group company.
 - j. Schlage Commercial Lock Division; an Ingersoll-Rand company.
 - k. Yale Security Inc.; an ASSA ABLOY Group company.

2.5 MANUAL FLUSH BOLTS

- A. Manual Flush Bolts: BHMA A156.16; minimum 3/4-inch throw; designed for mortising into door edge.

1. Manufacturers: Subject to compliance with requirements, provide products by one of the following:
 - a. Adams Rite Manufacturing Co.; an ASSA ABLOY Group company.
 - b. Burns Manufacturing Incorporated.
 - c. Don-Jo Mfg., Inc.
 - d. Door Controls International, Inc.
 - e. Hiawatha, Inc.
 - f. IVES Hardware; an Ingersoll-Rand company.
 - g. Trimco.
- B. Dustproof Strikes: Locking type, Grade 1, polished wrought brass, with 3/4-inch-diameter, spring-tension plunger.

2.6 AUTOMATIC AND SELF-LATCHING FLUSH BOLTS

- A. Automatic and Self-Latching Flush Bolts: BHMA A156.16; minimum 3/4-inch throw; designed for mortising into door edge.
 1. Manufacturers: Subject to compliance with requirements, provide products by one of the following:
 - a. Cal-Royal Products, Inc.
 - b. Door Controls International, Inc.
 - c. IVES Hardware; an Ingersoll-Rand company.
 - d. Trimco.
 - B. Automatic Flush Bolts: Grade 1, fabricated from steel and brass components, with spring-activated bolts that automatically retract when active leaf is opened and that automatically engage when active door depresses bolt trigger; listed and labeled for fire-rated doors. Provide brass or stainless-steel cover plate, top and bottom dustproof strikes, guides, guide supports, wear plates, and shims.

2.7 EXIT DEVICES AND AUXILIARY ITEMS

- A. Exit Devices and Auxiliary Items: BHMA A156.3.
 1. Manufacturers: Subject to compliance with requirements, provide products by one of the following:
 - a. Corbin Russwin Architectural Hardware; an ASSA ABLOY Group company.
 - b. Detex Corporation.
 - c. Door Controls International, Inc.
 - d. DORMA Architectural Hardware; Member of The DORMA Group North America.
 - e. Dor-O-Matic; an Ingersoll-Rand company.
 - f. Monarch Exit Devices & Panic Hardware; an Ingersoll-Rand company.
 - g. Precision Hardware, Inc.; Division of Stanley Security Solutions, Inc.
 - h. SARGENT Manufacturing Company; an ASSA ABLOY Group company.

-
- i. Von Duprin; an Ingersoll-Rand company.
 - j. Yale Security Inc.; an ASSA ABLOY Group company.
- B. Panic Exit Devices: Listed and labeled by a testing and inspecting agency acceptable to authorities having jurisdiction, for panic protection, based on testing according to UL 305.
- C. Fire Exit Devices: Devices complying with NFPA 80 that are listed and labeled by a testing and inspecting agency acceptable to authorities having jurisdiction, for fire and panic protection, based on testing according to UL 305 and NFPA 252.
- D. Rim Exit Devices: Grade 1.
- 1. Type: Type 1, rim.
 - 2. Grade: Grade 1.
 - 3. Actuating Bar: Cross bar.
 - 4. Material: Stainless steel.
- E. Tube-Steel Removable Mullions: With malleable-iron top and bottom retainers, and prepared for strikes as follows:
- 1. Strikes: Two standard recessed strikes.
- F. Fire-Exit Removable Mullions: Provide removable mullions for use with fire exit devices complying with NFPA 80 that are listed and labeled by a testing and inspecting agency acceptable to authorities having jurisdiction for fire and panic protection, based on testing according to UL 305 and NFPA 252. Use mullions only with exit devices for which they have been tested.
- G. Dummy Push Bar: Nonfunctioning push bar matching functional push bar.
- 1. Operation: Movable.
- H. Exit Device Outside Trim: Lever with cylinder; material and finish to match locksets, unless otherwise indicated.
- 1. Match design for lock trim, unless otherwise indicated.
- 2.8 LOCK CYLINDERS
- A. Lock Cylinders: Tumbler type, constructed from brass or bronze, stainless steel, or nickel silver.
- 1. Manufacturers: Subject to compliance with requirements, provide products by one of the following:
 - a. ASSA, Inc.; an ASSA ABLOY Group company.
 - b. Best Access Systems; Div. of Stanley Security Solutions, Inc.
 - c. Corbin Russwin Architectural Hardware; an ASSA ABLOY Group company.
 - d. Medeco Security Locks, Inc.; an ASSA ABLOY Group company.

- e. SARGENT Manufacturing Company; an ASSA ABLOY Group company.
 - f. Schlage Commercial Lock Division; an Ingersoll-Rand company.
 - g. Yale Security Inc.; an ASSA ABLOY Group company.
- B. Standard Lock Cylinders: BHMA A156.5; Grade 1; permanent cores that are removable; face finished to match lockset.
1. Number of Pins: Six.
 2. Type: Mortise type.
- C. High-Security Lock Cylinders: BHMA A156.30; Grade 1; Type M, mechanical; permanent cores that are removable; face finished to match lockset.
1. Number of Pins: Six.
 2. Type: Mortise type.
- D. Construction Master Keys: Provide cylinders with feature that permits voiding of construction keys without cylinder removal. Provide 10 construction master keys.
- E. Construction Cores: Provide construction cores that are replaceable by permanent cores. Provide 10 construction master keys.

2.9 KEYING

- A. Keying System: Factory registered, complying with guidelines in BHMA A156.28, Appendix A. Incorporate decisions made in keying conference.
1. No Master Key System: Only change keys operate cylinder.
 2. Master Key System: Change keys and a master key operate cylinders.
 3. Grand Master Key System: Change keys, a master key, and a grand master key operate cylinders.
 4. Great-Grand Master Key System: Change keys, a master key, a grand master key, and a great-grand master key operate cylinders.
 5. Existing System:
 - a. Master key or grand master key locks to Owner's existing system.
 - b. Re-key Owner's existing master key system into new keying system.
 6. Keyed Alike: Key all cylinders to same change key.
- B. Keys: Nickel silver.
1. Stamping: Permanently inscribe each key with a visual key control number and include the following notation:
 - a. Notation: "DO NOT DUPLICATE."
 2. Quantity: In addition to one extra key blank for each lock, provide the following:
 - a. Cylinder Change Keys: Three.

- b. Master Keys: Five.
- c. Grand Master Keys: Five.
- d. Great-Grand Master Keys: Five.

2.10 OPERATING TRIM

- A. Operating Trim: BHMA A156.6; stainless steel; unless otherwise indicated.
 - 1. Manufacturers: Subject to compliance with requirements, provide products by one of the following:
 - a. Burns Manufacturing Incorporated.
 - b. Don-Jo Mfg., Inc.
 - c. Forms + Surfaces.
 - d. Hager Companies.
 - e. Hiawatha, Inc.
 - f. IVES Hardware; An Ingersoll-Rand Company.
 - g. Rockwood Manufacturing Company.
 - h. Trimco.
- B. Flat Push Plates: 0.050 inch x 1/8 inch thick, 4 inches wide by 16 inches high with square corners and beveled edges; secured with exposed screws.
- C. Push-Pull Plates: 1/8 inch thick, 3-1/2 inches wide by 15-3/4 inches high with square corners, beveled edges, and raised integral lip; secured with exposed screws.

2.11 ACCESSORIES FOR PAIRS OF DOORS

- A. Coordinators: BHMA A156.3; consisting of active-leaf, hold-open lever and inactive-leaf release trigger; fabricated from steel with nylon-coated strike plates; with built-in, adjustable safety release; and with internal override.

2.12 SURFACE CLOSERS

- A. Surface Closers: BHMA A156.4; rack-and-pinion hydraulic type with adjustable sweep and latch speeds controlled by key-operated valves and forged-steel main arm. Comply with manufacturer's written recommendations for size of door closers depending on size of door, exposure to weather, and anticipated frequency of use. Provide factory-sized closers, adjustable to meet field conditions and requirements for opening force.
 - 1. Manufacturers: Subject to compliance with requirements, provide products by one of the following:
 - a. Corbin Russwin Architectural Hardware; an ASSA ABLOY Group company.
 - b. DORMA Architectural Hardware; Member of The DORMA Group North America.
 - c. LCN Closers; an Ingersoll-Rand company.

- d. Norton Door Controls; an ASSA ABLOY Group company.
- e. Rixson Specialty Door Controls; an ASSA ABLOY Group company.
- f. SARGENT Manufacturing Company; an ASSA ABLOY Group company.
- g. Yale Security Inc.; an ASSA ABLOY Group company.

B. Surface Closer with Cover: Grade 1; Modern Type with mechanism enclosed in cover.

1. Mounting: Hinge side, opposite hinge side, Parallel arm, Bracket, and Hinge side.
2. Type: Regular arm and Hold open.
3. Backcheck: Adjustable, effective between 60 and 85 degrees of door opening.
4. Cover Material: Molded plastic.
5. Closing Power Adjustment: At least 50 percent more than minimum tested value.

2.13 CLOSER HOLDER RELEASE DEVICES

A. Closer Holder Release Devices: BHMA A156.15; Grade 1; closer connected with separate or integral releasing and fire- or smoke-detecting devices. Door shall become self-closing on interruption of signal to release device. Automatic release is activated by loss of power.

1. Manufacturers: Subject to compliance with requirements, provide products by one of the following:
 - a. Corbin Russwin Architectural Hardware; an ASSA ABLOY Group company.
 - b. DORMA Architectural Hardware; Member of The DORMA Group North America.
 - c. LCN Closers; an Ingersoll-Rand company.
 - d. Norton Door Controls; an ASSA ABLOY Group company.
 - e. Rixson Specialty Door Controls; an ASSA ABLOY Group company.
 - f. SARGENT Manufacturing Company; an ASSA ABLOY Group company.
2. Type: Single-point hold open.
3. Options: Adjustable backcheck, Adjustable spring power, and Adjustable hold-open manual release force.

2.14 MECHANICAL STOPS AND HOLDERS

A. Wall- and Floor-Mounted Stops: BHMA A156.16; polished cast brass, bronze, or aluminum base metal.

1. Manufacturers: Subject to compliance with requirements, provide products by one of the following:
 - a. Architectural Builders Hardware Mfg., Inc.
 - b. Baldwin Hardware Corporation.
 - c. Burns Manufacturing Incorporated.
 - d. Cal-Royal Products, Inc.
 - e. Don-Jo Mfg., Inc.

- f. Door Controls International, Inc.
 - g. Hager Companies.
 - h. Hiawatha, Inc.
 - i. IVES Hardware; an Ingersoll-Rand company.
 - j. Rockwood Manufacturing Company.
 - k. Stanley Commercial Hardware; Div. of The Stanley Works.
 - l. Trimco.
- B. Rigid-Type Floor Stop: Grade 1; with rubber bumper; for expansion-shield application.
- C. Dome-Type Floor Stop: Grade 1; with minimum 1-inch-high bumper for doors without threshold and 1-3/8-inch-high bumper for doors with threshold; provide with extruded aluminum riser for carpet installations.
- D. Manual Combination Floor Stop and Holder: Grade 1; 3-1/2 inches long, with holder, keeper, and rubber bumper; for expansion-shield application.
- E. Wall Bumpers: Grade 1 or 2; with rubber bumper; 2-1/2-inch diameter, minimum 3/4-inch projection from wall; with backplate for concealed fastener installation; with concave bumper configuration Roller-type wall bumpers in first paragraph below are used to prevent interfering doors from hitting.

2.15 OVERHEAD STOPS AND HOLDERS

- A. Overhead Stops and Holders: BHMA A156.8.
1. Manufacturers: Subject to compliance with requirements, provide products by one of the following:
 - a. Architectural Builders Hardware Mfg., Inc.
 - b. Glynn-Johnson; An Ingersoll-Rand Company.
 - c. Rockwood Manufacturing Company.
 - d. SARGENT Manufacturing Company; an ASSA ABLOY Group company.
- B. Overhead Concealed Slide Holders: Type 1; Grade 1; hold open and release by push and pull of door unless control is set in inactive position; with stop, shock absorber, and adjustable holding pressure; for single or double-acting doors opening 110 degrees.
- C. Overhead Concealed, Nonfriction Slide Stops: Type 4; Grade 1 or 2; with nonfrictional element held under adjustable pressure and shock absorber; for single or double-acting doors opening 110 degrees.
- D. Overhead Concealed, Nonfriction Slide Holders: Type 4; Grade 1 or 2; with nonfrictional element held under adjustable pressure, automatic hold-open, and shock absorber; for single-acting doors opening 110 degrees.

2.16 DOOR GASKETING

- A. Door Gasketing: BHMA A156.22; air leakage not to exceed 0.50 cfm per foot of crack length for gasketing other than for smoke control, as tested according to ASTM E 283; with resilient or flexible seal strips that are easily replaceable and readily available from stocks maintained by manufacturer.
 - 1. Manufacturers: Subject to compliance with requirements, provide products by one of the following:
 - a. Hager Companies.
 - b. National Guard Products.
 - c. Pemko Manufacturing Co.; an ASSA ABLOY Group company.
 - d. Reese Enterprises, Inc.
 - e. Zero International.
- B. Rigid, Housed, Perimeter Gasketing: Sponge neoprene gasket material held in place by aluminum housing; fastened to frame stop with screws.
- C. Door Sweeps: Neoprene gasket material held in place by flat aluminum housing or flange; surface mounted to face of door with screws.
- D. Automatic Door Bottoms: Sponge neoprene gasket material held in place by aluminum lined with 0.047-inch thick lead] housing that automatically drops to form seal when door is closed; mounted to bottom edge of door with screws.
 - 1. Mounting: Mortised into bottom of door.
 - 2. Type: Low-closing-force type for doors required to meet accessibility requirements.

2.17 THRESHOLDS

- A. Thresholds: BHMA A156.21; fabricated to full width of opening indicated.
 - 1. Manufacturers: Subject to compliance with requirements, provide products by one of the following:
 - a. Hager Companies.
 - b. National Guard Products.
 - c. Pemko Manufacturing Co.; an ASSA ABLOY Group company.
 - d. Reese Enterprises, Inc.
 - e. Rixson Specialty Door Controls; an ASSA ABLOY Group company.
 - f. Zero International.
- B. Compressing-Top Thresholds: Metal member with compressible vinyl seal on top of threshold that seals against bottom of door; and base metal of aluminum.
- C. Saddle Thresholds:
 - 1. Type: Thermal break and fluted top.

2. Base Metal: Aluminum.

D. Latching/Rabbeted Panic Thresholds:

1. Type: Fluted, barrier free top.
2. Base Metal: Aluminum.

2.18 FOLDING DOOR HARDWARE

A. General: BHMA A156.14; complete sets including overhead rails, hangers, supports, bumpers, floor guides, and accessories indicated.

1. Manufacturers: Subject to compliance with requirements, available manufacturers offering products that may be incorporated into the Work include, but are not limited to, the following:

- a. Cox, Arthur, & Sons, Inc.
- b. Hager Companies.
- c. Henderson, PC, Inc.
- d. Johnson, L. E., Products, Inc.
- e. Stanley Commercial Hardware; Div. of The Stanley Works.

B. Bifolding Door Hardware: Rated for door panels weighing up to 50 lb (Grade 1); with rails and door hardware that allow horizontal and vertical adjustment.

1. Rail Material: Extruded aluminum.
2. Rail Configuration: V-grooved double leg.
3. Mounting: Top and bottom hung.
4. Wheel Assembly: Two wheel or four wheel, with roller bearings.

2.19 METAL PROTECTIVE TRIM UNITS

A. Metal Protective Trim Units: BHMA A156.6; fabricated from 0.050-inch-thick stainless steel; with manufacturer's standard machine or self-tapping screw fasteners.

1. Manufacturers: Subject to compliance with requirements, provide products by one of the following:

- a. Baldwin Hardware Corporation.
- b. Burns Manufacturing Incorporated.
- c. Don-Jo Mfg., Inc.
- d. Hiawatha, Inc.
- e. IVES Hardware; an Ingersoll-Rand company.
- f. Pawling Corporation.
- g. Rockwood Manufacturing Company.
- h. Trimco.

B. Armor Plates: 40 inches high by door width with allowance for frame stops.

- C. Kick Plates: 8 inches high by door width with allowance for frame stops.
- D. Mop Plates: 6 inches high by 1 inch less than door width.

2.20 AUXILIARY DOOR HARDWARE

- A. Auxiliary Hardware: BHMA A156.16.
 - 1. Manufacturers: Subject to compliance with requirements, available manufacturers offering products that may be incorporated into the Work include, but are not limited to, the following:
 - a. Baldwin Hardware Corporation.
 - b. Cal-Royal Products, Inc.
 - c. Don-Jo Mfg., Inc.
 - d. Hager Companies.
 - e. Rockwood Manufacturing Company.
 - f. Stanley Commercial Hardware; Div. of The Stanley Works.
 - g. Trimco.
- B. Silencers for Wood Door Frames: Grade 1; neoprene or rubber; minimum 5/8 by 3/4 inch; fabricated for drilled-in application to frame.
- C. Silencers for Metal Door Frames: Grade 1; neoprene or rubber; minimum diameter 1/2 inch; fabricated for drilled-in application to frame.

2.21 FABRICATION

- A. Manufacturer's Nameplate: Do not provide products that have manufacturer's name or trade name displayed in a visible location except in conjunction with required fire-rated labels and as otherwise approved by Architect.
 - 1. Manufacturer's identification is permitted on rim of lock cylinders only.
- B. Base Metals: Produce door hardware units of base metal indicated, fabricated by forming method indicated, using manufacturer's standard metal alloy, composition, temper, and hardness. Furnish metals of a quality equal to or greater than that of specified door hardware units and BHMA A156.18.
- C. Fasteners: Provide door hardware manufactured to comply with published templates prepared for machine, wood, and sheet metal screws. Provide screws that comply with commercially recognized industry standards for application intended, except aluminum fasteners are not permitted. Provide Phillips flat-head screws with finished heads to match surface of door hardware, unless otherwise indicated.
 - 1. Concealed Fasteners: For door hardware units that are exposed when door is closed, except for units already specified with concealed fasteners. Do not use through bolts for installation where bolt head or nut on opposite face is exposed unless it is the only means of securely attaching the door hardware. Where

- through bolts are used on hollow door and frame construction, provide sleeves for each through bolt.
2. Fire-Rated Applications:
 - a. Wood or Machine Screws: For the following:
 - 1) Hinges mortised to doors or frames; use threaded-to-the-head wood screws for wood doors and frames].
 - 2) Strike plates to frames.
 - 3) Closers to doors and frames.
 - b. Steel Through Bolts: For the following unless door blocking is provided:
 - 1) Surface hinges to doors.
 - 2) Closers to doors and frames.
 - 3) Surface-mounted exit devices.
 3. Spacers or Sex Bolts: For through bolting of hollow-metal doors.
 4. Fasteners for Wood Doors: Comply with requirements in DHI WDHS.2, "Recommended Fasteners for Wood Doors."
 5. Gasketing Fasteners: Provide noncorrosive fasteners for exterior applications and elsewhere as indicated.

2.22 FINISHES

- A. Provide finishes complying with BHMA A156.18 as indicated in door hardware schedule.
- B. Protect mechanical finishes on exposed surfaces from damage by applying a strippable, temporary protective covering before shipping.
- C. Appearance of Finished Work: Variations in appearance of abutting or adjacent pieces are acceptable if they are within one-half of the range of approved Samples. Noticeable variations in the same piece are not acceptable. Variations in appearance of other components are acceptable if they are within the range of approved Samples and are assembled or installed to minimize contrast.

PART 3 - EXECUTION

3.1 EXAMINATION

- A. Examine doors and frames, with Installer present, for compliance with requirements for installation tolerances, labeled fire-rated door assembly construction, wall and floor construction, and other conditions affecting performance.
- B. Proceed with installation only after unsatisfactory conditions have been corrected.

3.2 PREPARATION

- A. Steel Doors and Frames: For surface applied door hardware, drill and tap doors and frames according to ANSI/SDI A250.6.
- B. Wood Doors: Comply with DHI WDHS.5 "Recommended Hardware Reinforcement Locations for Mineral Core Wood Flush Doors."

3.3 INSTALLATION

- A. Mounting Heights: Mount door hardware units at heights to comply with the following unless otherwise indicated or required to comply with governing regulations.
 - 1. Standard Steel Doors and Frames: ANSI/SDI A250.8.
 - 2. Custom Steel Doors and Frames: HMMA 831.
 - 3. Wood Doors: DHI WDHS.3, "Recommended Locations for Architectural Hardware for Wood Flush Doors."
- B. Install each door hardware item to comply with manufacturer's written instructions. Where cutting and fitting are required to install door hardware onto or into surfaces that are later to be painted or finished in another way, coordinate removal, storage, and reinstallation of surface protective trim units with finishing work specified in Division 09 Sections. Do not install surface-mounted items until finishes have been completed on substrates involved.
 - 1. Set units level, plumb, and true to line and location. Adjust and reinforce attachment substrates as necessary for proper installation and operation.
 - 2. Drill and countersink units that are not factory prepared for anchorage fasteners. Space fasteners and anchors according to industry standards.
- C. Hinges: Install types and in quantities indicated in door hardware schedule but not fewer than the number recommended by manufacturer for application indicated or one hinge for every 30 inches of door height, whichever is more stringent, unless other equivalent means of support for door, such as spring hinges or pivots, are provided.
- D. Intermediate Offset Pivots: Where offset pivots are indicated, provide intermediate offset pivots in quantities indicated in door hardware schedule but not fewer than one intermediate offset pivot per door and one additional intermediate offset pivot for every 30 inches of door height greater than 90 inches.
- E. Lock Cylinders: Install construction cores to secure building and areas during construction period.
 - 1. Replace construction cores with permanent cores as indicated in keying schedule.
 - 2. Furnish permanent cores to Owner for installation.
- F. Key Control System: Tag keys and place them on markers and hooks in key control system cabinet, as determined by final keying schedule.

- G. Thresholds: Set thresholds for exterior doors and other doors indicated in full bed of sealant complying with requirements specified in Division 07 Section "Joint Sealants."
- H. Stops: Provide floor stops for doors unless wall or other type stops are indicated in door hardware schedule. Do not mount floor stops where they will impede traffic.
- I. Perimeter Gasketing: Apply to head and jamb, forming seal between door and frame.
- J. Meeting Stile Gasketing: Fasten to meeting stiles, forming seal when doors are closed.
- K. Door Bottoms: Apply to bottom of door, forming seal with threshold when door is closed.

3.4 FIELD QUALITY CONTROL

- A. Independent Architectural Hardware Consultant: Owner will engage a qualified independent Architectural Hardware Consultant to perform inspections and to prepare inspection reports.
 - 1. Independent Architectural Hardware Consultant will inspect door hardware and state in each report whether installed work complies with or deviates from requirements, including whether door hardware is properly installed and adjusted.

3.5 ADJUSTING

- A. Initial Adjustment: Adjust and check each operating item of door hardware and each door to ensure proper operation or function of every unit. Replace units that cannot be adjusted to operate as intended. Adjust door control devices to compensate for final operation of heating and ventilating equipment and to comply with referenced accessibility requirements.
 - 1. Spring Hinges: Adjust to achieve positive latching when door is allowed to close freely from an open position of 30 degrees.
 - 2. Door Closers: Adjust sweep period to comply with accessibility requirements and requirements of authorities having jurisdiction.
- B. Occupancy Adjustment: Approximately three months after date of Substantial Completion, Installer's Architectural Hardware Consultant shall examine and readjust each item of door hardware, including adjusting operating forces, as necessary to ensure function of doors, and door hardware.

3.6 CLEANING AND PROTECTION

- A. Clean adjacent surfaces soiled by door hardware installation.
- B. Clean operating items as necessary to restore proper function and finish.

- C. Provide final protection and maintain conditions that ensure that door hardware is without damage or deterioration at time of Substantial Completion.

3.7 DEMONSTRATION

- A. Engage a factory-authorized service representative to train Owner's maintenance personnel to adjust, operate, and maintain door hardware and door hardware finishes. Refer to Division 01 Section "Demonstration and Training."

3.8 DOOR HARDWARE SCHEDULE

HW-4A	Double Door Interior		Manufacturer
	Quantity	Description	
	8	HTAB850 x 4.5 x 4.5 x 630 x Torx L9080T Lockset x L17 x L Full Face	Hager
	1	x630	Schlage
	1	FB458 Head & Foot Flush Bolts x 630	Ives
	1	DP1 Dust Proof Strike x 630	Ives
	1	4040-3077 x AL Closer	LCN
	1	409 x 630 Wall Stop	Rockwood
	3	SR64 x Grey Silencer	Ives

HW-5	Double Door Exterior (Rim)		Manufacturer
	Quantity	Description	
	8	HTAB850 x 4.5 x 4.5 x 630 x Torx	Hager
	2	99FRim Fire Exit Device x 696NL x 626	Von Duprin
	1	4954-7 Removable Mullion x USP	Von Duprin
	2	4040-3077 x AL Closer	LCN
	2	106x70C x 630 Pull Plate	Rockwood
	2	90S x SP28 Overhead Stop	Glynn-Johnson
	2	319RC Gasketing x 17' (Head & Jamb)	Pemko
	2	315NC Door Bottom Sweep x Door Width	Pemko
	2	346C Drip x Door Width	Pemko
	2	179TA Threshold x Door Width	Pemko
	6	SR64 x Grey Silencer	Ives

END OF SECTION 087111

SECTION 089119 - FIXED LOUVERS

PART 1 - GENERAL

1.1 RELATED DOCUMENTS

- A. Drawings and general provisions of the Contract, including General and Supplementary Conditions and Division 01 Specification Sections, apply to this Section.

1.2 SUMMARY

- A. Section Includes:
 - 1. Fixed, extruded-aluminum louvers.

1.3 DEFINITIONS

- A. Louver Terminology: Definitions of terms for metal louvers contained in AMCA 501 apply to this Section unless otherwise defined in this Section or in referenced standards.
- B. Horizontal Louver: Louver with horizontal blades (i.e., the axes of the blades are horizontal).
- C. Drainable-Blade Louver: Louver with blades having gutters that collect water and drain it to channels in jambs and mullions, which carry it to bottom of unit and away from opening.

1.4 ACTION SUBMITTALS

- A. Product Data: For each type of product.
 - 1. For louvers specified to bear AMCA seal, include printed catalog pages showing specified models with appropriate AMCA Certified Ratings Seals.
- B. Shop Drawings: For louvers and accessories. Include plans, elevations, sections, details, and attachments to other work. Show frame profiles and blade profiles, angles, and spacing.
 - 1. Show weep paths, gaskets, flashing, sealant, and other means of preventing water intrusion.
 - 2. Show mullion profiles and locations.
- C. Samples: For each type of metal finish required.

- D. Delegated-Design Submittal: For louvers indicated to comply with structural performance requirements, including analysis data signed and sealed by the qualified professional engineer responsible for their preparation.

1.5 INFORMATIONAL SUBMITTALS

- A. Product Test Reports: Based on evaluation of comprehensive tests performed according to AMCA 500-L by a qualified testing agency or by manufacturer and witnessed by a qualified testing agency, for each type of louver and showing compliance with performance requirements specified.
- B. Windborne-debris-impact-resistance test reports.

1.6 QUALITY ASSURANCE

- A. Welding Qualifications: Qualify procedures and personnel according to the following:
 - 1. AWS D1.2/D1.2M, "Structural Welding Code - Aluminum."
 - 2. AWS D1.6/D1.6M, "Structural Welding Code - Stainless Steel."
- B. Product Qualifications:
 - 1. Recycled Content: Provide louver that incorporate recycled content materials. The louver shall consist of the following recycled content:
 - a. Fabricated aluminum recycled content 73% by weight. 18% post-consumer, 55 % pre-consumer.

1.7 FIELD CONDITIONS

- A. Field Measurements: Verify actual dimensions of openings by field measurements before fabrication.

PART 2 - PRODUCTS

2.1 MANUFACTURERS

- A. Source Limitations: Obtain louvers from single source from a single manufacturer where indicated to be of same type, design, or factory-applied color finish.

2.2 PERFORMANCE REQUIREMENTS

- A. Delegated Design: Design louvers, including comprehensive engineering analysis by a qualified professional engineer, using structural performance requirements and design criteria indicated.

- B. Structural Performance: Louvers shall withstand the effects of gravity loads and the following loads and stresses within limits and under conditions indicated without permanent deformation of louver components, noise or metal fatigue caused by louver-blade rattle or flutter, or permanent damage to fasteners and anchors. Wind pressures shall be considered to act normal to the face of the building.
1. Wind Loads: Determine loads based on a uniform pressure of 30 lbf/sq. ft., acting inward or outward.
- C. Windborne-Debris-Impact Resistance: Louvers located within 30 feet of grade shall pass basic-protection, large-missile testing requirements in ASTM E 1996 for Wind Zone 2 when tested according to ASTM E 1886. Test specimens shall be no smaller in width and length than louvers indicated for use on Project.
- D. Louver Performance Ratings: Provide louvers complying with requirements specified, as demonstrated by testing manufacturer's stock units identical to those provided, except for length and width according to AMCA 500-L.
- E. Thermal Movements: Allow for thermal movements from ambient and surface temperature changes.
1. Temperature Change (Range): 120 deg F, ambient; 180 deg F, material surfaces.
- F. SMACNA Standard: Comply with recommendations in SMACNA's "Architectural Sheet Metal Manual" for fabrication, construction details, and installation procedures.

2.3 FIXED, EXTRUDED-ALUMINUM LOUVERS

- A. Horizontal, Drainable-Blade Louver [WL]:
1. Basis-of-Design Product: Subject to compliance with requirements, provide Ruskin Company ELF6375DXH or comparable product by one of the following:
 - a. Airolite Company, LLC (The).
 - b. American Warming and Ventilating; a Mestek Architectural Group company.
 - c. Arrow United Industries.
 - d. Cesco Products; a division of MESTEK, Inc.
 - e. Construction Specialties, Inc.
 - f. Greenheck Fan Corporation.
 - g. Louvers & Dampers, Inc.; a division of Mestek, Inc.
 - h. Pottorff.
 - i. United Enertech Corporation.
 2. Louver Depth: 6 inches.
 3. Frame and Blade Nominal Thickness: Not less than 0.125 inch.
 4. Mullion Type: Exposed.
 5. Louver Performance Ratings:

- a. Free Area: Not less than 9.08 sq. ft. for 48-inch- wide by 48-inch- high louver.
 - b. Point of Beginning Water Penetration: Not less than 1000 fpm.
 - c. Air Performance: Not more than 0.10-inch wg static pressure drop at 750-fpm free-area intake velocity.
 - d. Air Performance: Not more than 0.15-inch wg static pressure drop at 900-fpm free-area exhaust velocity.
6. AMCA Seal: Mark units with AMCA Certified Ratings Seal.
 7. Recycled Content: 18% post-consumer. 55% pre-consumer, post-industrial. 73% total by weight.

2.4 LOUVER SCREENS

- A. General: Provide screen at each exterior louver.
 1. Screen Location for Fixed Louvers: Interior face.
 2. Screening Type: Bird screening except where insect screening is indicated.
- B. Secure screen frames to louver frames with stainless-steel security machine screws, spaced a maximum of 6 inches from each corner and at 12 inches o.c.
- C. Louver Screen Frames: Fabricate with mitered corners to louver sizes indicated.
 1. Metal: Same type and form of metal as indicated for louver to which screens are attached. Reinforce extruded-aluminum screen frames at corners with clips.
 2. Finish: Same finish as louver frames to which louver screens are attached.
 3. Type: Non-rewirable, U-shaped frames.
- D. Louver Screening for Aluminum Louvers:
 1. Bird Screening: Aluminum, 1/2-inch- square mesh, 0.063-inch wire.
 2. Insect Screening: Aluminum, 18-by-16 mesh, 0.012-inch wire.

2.5 BLANK-OFF PANELS

- A. Insulated, Blank-Off Panels: Laminated panels consisting of an insulating core surfaced on back and front with metal sheets and attached to back of louver.
 1. Thickness: 2 inches.
 2. Metal Facing Sheets: Aluminum sheet, not less than 0.032-inch nominal thickness.
 3. Metal Facing Sheets: Stainless-steel sheet, not less than 0.031-inch nominal thickness.
 4. Insulating Core: Rigid, glass-fiber-board insulation or extruded-polystyrene foam.
 5. Edge Treatment: Trim perimeter edges of blank-off panels with louver manufacturer's standard extruded-aluminum-channel frames, not less than 0.080-inch nominal thickness, with corners mitered and with same finish as panels.

6. Seal perimeter joints between panel faces and louver frames with gaskets or sealant.
7. Panel Finish: Same finish applied to louvers.
8. Attach blank-off panels with sheet metal security screws.

2.6 MATERIALS

- A. Aluminum Extrusions: ASTM B 221, Alloy 6063-T5, T-52, or T6.
- B. Aluminum Sheet: ASTM B 209, Alloy 3003 or 5005 with temper as required for forming, or as otherwise recommended by metal producer for required finish.
- C. Stainless-Steel Sheet: ASTM A 240/A 240M, Type 304, No. 2B finish.
- D. Fasteners: Use types and sizes to suit unit installation conditions.
 1. Use security type, tamper-resistant screws for exposed fasteners unless otherwise indicated.
 2. For fastening aluminum, use aluminum or 300 series stainless-steel fasteners.
 3. For fastening galvanized steel, use hot-dip-galvanized steel or 300 series stainless-steel fasteners.
 4. For fastening stainless steel, use 300 series stainless-steel fasteners.
 5. For color-finished louvers, use fasteners with heads that match color of louvers.
- E. Postinstalled Fasteners for Concrete and Masonry: Torque-controlled expansion anchors, made from stainless-steel components, with capability to sustain, without failure, a load equal to 4 times the loads imposed, for concrete, or 6 times the load imposed for masonry, as determined by testing according to ASTM E 488, conducted by a qualified independent testing agency.
- F. Bituminous Paint: Cold-applied asphalt emulsion complying with ASTM D 1187.

2.7 FABRICATION

- A. Factory assemble louvers to minimize field splicing and assembly. Disassemble units as necessary for shipping and handling limitations. Clearly mark units for reassembly and coordinated installation.
- B. Vertical Assemblies: Where height of louver units exceeds fabrication and handling limitations, fabricate units to permit field-bolted assembly with close-fitting joints in jambs and mullions, reinforced with splice plates.
 1. Continuous Vertical Assemblies: Fabricate units without interrupting blade-spacing pattern unless horizontal mullions are indicated.
 2. Horizontal Mullions: Provide horizontal mullions at joints unless continuous vertical assemblies are indicated.
- C. Maintain equal louver blade spacing, including separation between blades and frames at head and sill, to produce uniform appearance.

- D. Fabricate frames, including integral sills, to fit in openings of sizes indicated, with allowances made for fabrication and installation tolerances, adjoining material tolerances, and perimeter sealant joints.
 - 1. Frame Type: Channel unless otherwise indicated.
- E. Include supports, anchorages, and accessories required for complete assembly.
- F. Provide vertical mullions of type and at spacings indicated, but not more than is recommended by manufacturer, or 72 inches o.c., whichever is less.
 - 1. Fully Recessed Mullions: Where indicated, provide mullions fully recessed behind louver blades. Where length of louver exceeds fabrication and handling limitations, fabricate with close-fitting blade splices designed to permit expansion and contraction.
 - 2. Semirecessed Mullions: Where indicated, provide mullions partly recessed behind louver blades so louver blades appear continuous. Where length of louver exceeds fabrication and handling limitations, fabricate with interlocking split mullions and close-fitting blade splices designed to permit expansion and contraction.
 - 3. Exposed Mullions: Where indicated, provide units with exposed mullions of same width and depth as louver frame. Where length of louver exceeds fabrication and handling limitations, provide interlocking split mullions designed to permit expansion and contraction.
 - 4. Exterior Corners: Prefabricated corner units with mitered and welded blades and with fully recessed mullions at corners.
- G. Provide subsills made of same material as louvers or extended sills for recessed louvers.
- H. Join frame members to each other and to fixed louver blades with fillet welds concealed from view unless otherwise indicated or size of louver assembly makes bolted connections between frame members necessary.

2.8 ALUMINUM FINISHES

- A. Finish louvers after assembly.
- B. Conversion-Coated Finish: AA-C12C42 (Chemical Finish: cleaned with inhibited chemicals; Chemical Finish: acid-chromate-fluoride-phosphate conversion coating).
- C. High-Performance Organic Finish: Three-coat fluoropolymer finish complying with AAMA 2605 and containing not less than 70 percent PVDF resin by weight in both color coat and clear topcoat. Prepare, pretreat, and apply coating to exposed metal surfaces to comply with coating and resin manufacturers' written instructions.
 - 1. Color and Gloss: Match Architect's sample.

2.9 STAINLESS-STEEL SHEET FINISHES

- A. Repair sheet finish by grinding and polishing irregularities, weld spatter, scratches, and forming marks to match surrounding finish.

PART 3 - EXECUTION

3.1 EXAMINATION

- A. Examine substrates and openings, with Installer present, for compliance with requirements for installation tolerances and other conditions affecting performance of the Work.
- B. Proceed with installation only after unsatisfactory conditions have been corrected.

3.2 PREPARATION

- A. Coordinate setting drawings, diagrams, templates, instructions, and directions for installation of anchorages that are to be embedded in concrete or masonry construction. Coordinate delivery of such items to Project site.

3.3 INSTALLATION

- A. Locate and place louvers level, plumb, and at indicated alignment with adjacent work.
- B. Use concealed anchorages where possible. Provide brass or lead washers fitted to screws where required to protect metal surfaces and to make a weathertight connection.
- C. Form closely fitted joints with exposed connections accurately located and secured.
- D. Provide perimeter reveals and openings of uniform width for sealants and joint fillers, as indicated.
- E. Protect unpainted galvanized and nonferrous-metal surfaces that are in contact with concrete, masonry, or dissimilar metals from corrosion and galvanic action by applying a heavy coating of bituminous paint or by separating surfaces with waterproof gaskets or nonmetallic flashing.
- F. Install concealed gaskets, flashings, joint fillers, and insulation as louver installation progresses, where weathertight louver joints are required. Comply with Section 079200 "Joint Sealants" for sealants applied during louver installation.

3.4 ADJUSTING AND CLEANING

- A. Clean exposed louver surfaces that are not protected by temporary covering, to remove fingerprints and soil during construction period. Do not let soil accumulate during construction period.
- B. Before final inspection, clean exposed surfaces with water and a mild soap or detergent not harmful to finishes. Thoroughly rinse surfaces and dry.
- C. Restore louvers damaged during installation and construction so no evidence remains of corrective work. If results of restoration are unsuccessful, as determined by Architect, remove damaged units and replace with new units.
 - 1. Touch up minor abrasions in finishes with air-dried coating that matches color and gloss of, and is compatible with, factory-applied finish coating.

END OF SECTION 089119

SECTION 099123 - INTERIOR PAINTING

PART 1 - GENERAL

1.1 RELATED DOCUMENTS

- A. Drawings and general provisions of the Contract, including General and Supplementary Conditions and Division 01 Specification Sections, apply to this Section.

1.2 SUMMARY

- A. This Section includes surface preparation and the application of paint systems on the following interior substrates:
 - 1. Concrete.
 - 2. Concrete masonry units (CMU), new or existing.
 - 3. Steel.
 - 4. Galvanized metal.
 - 5. Gypsum board.
 - 6. Security Hollow Metal Wall Panel System
- B. Related Sections include the following:
 - 7. Division 05 Sections for shop priming of metal substrates with primers specified in this Section.
 - 8. Division 08 Sections for factory priming windows and doors with primers specified in this Section.

1.3 SUBMITTALS

- A. Product Data: For each type of product indicated.
- B. Samples for Initial Selection: For each type of topcoat product indicated.
- C. Samples for Verification: For each type of paint system and in each color and gloss of topcoat indicated.
 - 1. Submit Samples on rigid backing, 8 inches square.
 - 2. Step coats on Samples to show each coat required for system.
 - 3. Label each coat of each Sample.
 - 4. Label each Sample for location and application area.
- D. Product List: For each product indicated, include the following:
 - 1. Cross-reference to paint system and locations of application areas. Use same designations indicated on Drawings and in schedules.

2. Printout of current "MPI Approved Products List" for each product category specified in Part 2, with the proposed product highlighted.

E. LEED Submittal:

1. Product Data for Credit EQ 4.2: For paints, including printed statement of VOC content and chemical components.

1.4 QUALITY ASSURANCE

A. MPI Standards:

1. Products: Complying with MPI standards indicated and listed in "MPI Approved Products List."
2. Preparation and Workmanship: Comply with requirements in "MPI Architectural Painting Specification Manual" for products and paint systems indicated.

B. Mockups: Apply benchmark samples of each paint system indicated and each color selected and finish to verify preliminary selections made under sample submittals and to demonstrate aesthetic effects and set quality standards for materials and execution.

1. Architect will select one surface to represent surfaces and conditions for application of each paint system specified in Part 3.
 - a. Wall and Ceiling Surfaces: Provide samples of at least 100 sq. ft.
 - b. Other Items: Architect will designate items or areas required.
2. Apply benchmark samples after permanent lighting and other environmental services have been activated.
3. Final approval of color selections will be based on benchmark samples.
 - a. If preliminary color selections are not approved, apply additional benchmark samples of additional colors selected by Architect at no added cost to Owner.

1.5 DELIVERY, STORAGE, AND HANDLING

A. Store materials not in use in tightly covered containers in well-ventilated areas with ambient temperatures continuously maintained at not less than 45 deg F.

1. Maintain containers in clean condition, free of foreign materials and residue.
2. Remove rags and waste from storage areas daily.

1.6 PROJECT CONDITIONS

A. Apply paints only when temperature of surfaces to be painted and ambient air temperatures are between 50 and 95 deg F

- B. Do not apply paints when relative humidity exceeds 85 percent; at temperatures less than 5 deg F above the dew point; or to damp or wet surfaces.

1.7 EXTRA MATERIALS

- A. Furnish extra materials described below that are from same production run (batch mix) as materials applied and that are packaged for storage and identified with labels describing contents.

- 1. Quantity: Furnish an additional 5 percent, but not less than 1 gal. of each material and color applied.

PART 2 - PRODUCTS

2.1 MANUFACTURERS

- A. Manufacturers: Subject to compliance with requirements, manufacturers
- B. offering products that may be incorporated into the Work include, but are not limited to the following:
- C. Alkyd Paints:
 - a. Benjamin Moore & Co.
 - b. PPG Architectural Finishes, Inc.
 - c. Sherwin-Williams Company (The).
- 1. Epoxy Block Filler and Epoxy Coatings:
 - a. PPG Architectural Finishes, Inc.
 - b. Sherwin-Williams Company (The)
 - c. Coronado Paint

2.2 PAINT, GENERAL

- A. Paints in subsequent articles are referenced to MPI paint categories.
 - 1. Within each MPI paint category, only products of a specified manufacturer are acceptable.
 - 2. Where specified manufacturer has listed a product other than that manufacturer's premium architectural line product or does not have a listed product, provide manufacturer's premium architectural line product meeting specified performance requirements.
- B. Material Compatibility:
 - 1. Provide materials for use within each paint system that are compatible with one another and substrates indicated, under conditions of service and

- application as demonstrated by manufacturer, based on testing and field experience.
2. For each coat in a paint system, provide products recommended in writing by manufacturers of topcoat for use in paint system and on substrate indicated.
- C. VOC Content of Field-Applied Interior Paints and Coatings: Provide products that comply with the following limits for VOC content, exclusive of colorants added to a tint base, when calculated according to 40 CFR 59, Subpart D (EPA Method 24); these requirements do not apply to paints and coatings that are applied in a fabrication or finishing shop:
1. Nonflat Paints, Coatings, and Primers: VOC content of not more than 150 g/L.
 2. Anti-Corrosive and Anti-Rust Paints Applied to Ferrous Metals: VOC not more than 250 g/L.
 3. Nonflat Topcoat Paints: VOC content of not more than 150 g/L.
 4. Anti-Corrosive and Anti-Rust Paints Applied to Ferrous Metals: VOC not more than 250 g/L.
 5. Primers, Sealers, and Undercoaters: VOC content of not more than 200 g/L.
- D. Chemical Components of Field-Applied Interior Paints and Coatings: Provide topcoat paints and anti-corrosive and anti-rust paints applied to ferrous metals that comply with the following chemical restrictions; these requirements do not apply to paints and coatings that are applied in a fabrication or finishing shop:
- Aromatic Compounds: Paints and coatings shall not contain more than 1.0 percent by weight of total aromatic compounds (hydrocarbon compounds containing one or more benzene rings).
- Restricted Components: Paints and coatings shall not contain any of the following:
- a. Acrolein.
 - b. Acrylonitrile.
 - c. Antimony.
 - d. Benzene.
 - e. Butyl benzyl phthalate.
 - f. Cadmium.
 - g. Di (2-ethylhexyl) phthalate.
 - h. Di-n-butyl phthalate.
 - i. Di-n-octyl phthalate.
 - j. 1,2-dichlorobenzene.
 - k. Diethyl phthalate.
 - l. Dimethyl phthalate.
 - m. Ethylbenzene.
 - n. Formaldehyde.
 - o. Hexavalent chromium.
 - p. Isophorone.
 - q. Lead.
 - r. Mercury.
 - s. Methyl ethyl ketone.
 - t. Methyl isobutyl ketone.
 - u. Methylene chloride.

- v. Naphthalene.
- w. Toluene (methylbenzene).
- x. 1,1,1-trichloroethane.
- y. Vinyl Chloride

2.3 BLOCK FILLERS

A. Solvent Based Epoxy Block Filler: MPI #116. (Use with Epoxy Coating System)

1. VOC Content: E Range of E3.
2. Apply filler coat on new and previously unpainted concrete masonry units at a rate to ensure complete coverage with all pores filled. If required, provide in two (2) or more coats.
3. Spot prime previously painted concrete masonry unit surfaces as needed.

2.4 EPOXY COATING SYSTEM:

A. Solvent Based Epoxy Coating System (Semigloss): MPI #77 (Gloss Level 5).

1. VOC Content: E Range of E3.
2. Apply two (2) coats.

2.5 PRIMERS/SEALERS

A. Interior Alkyd Primer/Sealer: MPI #45.

1. VOC Content: E Range of E1.
2. Environmental Performance Rating: EPR1.

2.6 METAL PRIMERS

A. Alkyd Anticorrosive Metal Primer: MPI #79.1. VOC Content: E Range of E1.

2.7 ALKYD PAINTS

A. Interior Alkyd (Semigloss): MPI #47 (Gloss Level 5).

1. VOC Content: E Range of E1.
2. Environmental Performance Rating: EPR 1.

PART 3 - EXECUTION

3.1 EXAMINATION

- A. Examine substrates and conditions, with Applicator present, for compliance with requirements for maximum moisture content and other conditions affecting performance of work.
- B. Maximum Moisture Content of Substrates: When measured with an electronic moisture meter as follows
- C.

1. Concrete: 12 percent.
 2. Masonry (CMU): 12 percent.
 3. Gypsum Board: 12 percent.
- D. Verify suitability of substrates, including surface conditions and compatibility with existing finishes and primers.
- E. Begin coating application only after unsatisfactory conditions have been corrected and Surfaces are dry.
1. Beginning coating application constitutes Contractor's acceptance of substrates and conditions.

3.2 PREPARATION

- A. Comply with manufacturer's written instructions and recommendations in "MPI Architectural Painting Specification Manual" applicable to substrates indicated.
- B. Remove plates, machined surfaces, and similar items already in place that are not to be painted. If removal is impractical or impossible because of size or weight of item, provide surface-applied protection before surface preparation and painting.
- a. After completing painting operations, use workers skilled in the trades involved to reinstall items that were removed. Remove surface-applied protection if any.
 - b. Do not paint over labels of independent testing agencies or equipment name, identification, performance rating, or nomenclature plates.
- C. Clean substrates of substances that could impair bond of paints, including dirt, oil, grease, and incompatible paints and encapsulants.
1. Remove incompatible primers and reprime substrate with compatible primers as required to produce paint systems indicated.
- D. Concrete Substrates: Remove release agents, curing compounds, efflorescence, and chalk. Do not paint surfaces if moisture content or alkalinity of surfaces to be painted exceeds that permitted in manufacturer's written instructions.
- E. Concrete Masonry Substrates: Remove efflorescence and chalk. Do not paint surfaces if moisture content or alkalinity of surfaces to be painted exceeds that permitted in manufacturer's written instructions.
- F. Steel Substrates: Remove rust and loose mill scale. Clean using methods recommended in writing by paint manufacturer.
- G. Galvanized-Metal Substrates: Remove grease and oil residue from galvanized sheet metal fabricated from coil stock by mechanical methods to produce clean, lightly etched surfaces that promote adhesion of subsequently applied paints.

- H. Gypsum Board Substrates: Do not begin paint application until finishing compound is dry and sanded smooth.

3.3 APPLICATION

- A. Apply paints according to manufacturer's written instructions.
 - 1. Use applicators and techniques suited for paint and substrate indicated.
 - 2. Paint surfaces behind movable equipment and furniture same as similar exposed surfaces. Before final installation, paint surfaces behind permanently fixed equipment or furniture with prime coat only.
 - 3. Paint front and backsides of access panels, removable or hinged covers, and similar hinged items to match exposed surfaces.
- B. Tint each undercoat a lighter shade to facilitate identification of each coat if multiple coats of same material are to be applied. Tint undercoats to match color of topcoat, but provide sufficient difference in shade of undercoats to distinguish each separate coat.
- C. If undercoats or other conditions show through topcoat, apply additional coats until cured film has a uniform paint finish, color, and appearance.
- D. Apply paints to produce surface films without cloudiness, spotting, holidays, laps, brush marks, roller tracking, runs, sags, ropiness, or other surface imperfections. Cut in sharp lines and color breaks.
- E. Painting Mechanical and Electrical Work: Paint items exposed in equipment rooms and occupied spaces including, but not limited to, the following:
 - 1. Mechanical Work:
 - a. Uninsulated metal piping.
 - b. Uninsulated plastic piping.
 - c. Pipe hangers and supports.
 - d. Tanks that do not have factory-applied final finishes.
 - e. Visible portions of internal surfaces of metal ducts, without liner, behind air inlets and outlets.
 - f. Duct, equipment, and pipe insulation having cotton or canvas insulation covering or other paintable jacket material.
 - g. Mechanical equipment that is indicated to have a factory-primed finish for field painting.
 - 2. Electrical Work:
 - a. Switchgear.
 - b. Panelboards.
 - c. Electrical equipment that is indicated to have a factory-primed finish for field painting.

3.4 FIELD QUALITY CONTROL

- A. Testing of Paint Materials: Owner reserves the right to invoke the following procedure at any time and as often as Owner deems necessary during the period when paints are being applied:
1. Owner will engage the services of a qualified testing agency to sample paint materials being used. Samples of material delivered to Project site will be taken, identified, sealed, and certified in presence of Contractor.
 2. Testing agency will perform tests for compliance with product requirements.
 3. Owner may direct Contractor to stop applying paints if test results show materials being used do not comply with product requirements. Contractor shall remove noncomplying-paint materials from Project site, pay for testing, and repaint surfaces painted with rejected materials. Contractor will be required to remove rejected materials from previously painted surfaces if, on repainting with complying materials, the two paints are incompatible.

3.5 CLEANING AND PROTECTION

- A. At end of each workday, remove rubbish, empty cans, rags, and other discarded materials from Project site.
- B. After completing paint application, clean spattered surfaces. Remove spattered paints by washing, scraping, or other methods. Do not scratch or damage adjacent finished surfaces.
- C. Protect work of other trades against damage from paint application. Correct damage to work of other trades by cleaning, repairing, replacing, and refinishing, as approved by Architect, and leave in an undamaged condition.
- D. At completion of construction activities of other trades, touch up and restore damaged or defaced painted surfaces.

3.6 INTERIOR PAINTING SCHEDULE

- A. CMU Substrates:
1. Solvent Based Epoxy Coating System.
 - a. Prime Coat: Interior solvent based epoxy block filler, MPI 116.
 - b. Intermediate Coat: Same as topcoat.
 - c. Topcoat: solvent based epoxy coating, semi-gloss, MPI #77.
- B. Concrete Substrates, Nontraffic Surfaces:
1. Solvent Based Epoxy Coating System.
 - a. Coat: Interior solvent based epoxy block filler, MPI 116.

-
- b. Intermediate Coat: Same as topcoat.
 - c. Prime Topcoat: solvent based epoxy coating, semi-gloss, MPI #77.
2. Alkyd System: MPI INT 3.1D.
- a. Prime Coat: Interior latex primer/sealer.
 - b. Intermediate Coat: Interior alkyd matching topcoat.
 - c. Topcoat: Interior alkyd, semi-gloss, MPI #48.
- C. Security Hollow Metal Wall panel System
- 2. The panel manufacturer is responsible for prime and finish paint material and labor.
 - 3. All panels shall be factory primed with Prime Coat Corporation (847-972-2141) PC 105 and finish coated in the field with Prime Coat PC 509 with anti-microbial or approved primer and finish coat as manufactured by Rock-Tred Corporation (224-377-6048) or Vanberg Coatings (913-599-5939).
- D. Gypsum Board Substrates:
- 4. Alkyd over Latex Primer System: MPI INT 9.2C.
- a. Prime Coat: Interior latex primer/sealer, MPI #50.
 - b. Intermediate Coat: Same as topcoat.
 - c. Topcoat: Interior alkyd G5, semi-gloss, MPI #47.
- E. Galvanized Metal Substrates:
- 3. Alkyd System: MPI INT 5.3G.
- a. Intermediate Coat: Same as topcoat.
 - b. Topcoat: Interior alkyd G5, semi-gloss, MPI #47
- F. Steel Substrates:
- 4. Quick-Drying Enamel System: MPI INT 5.1A.
- a. Prime Coat: Quick-drying alkyd metal primer.
 - b. Intermediate Coat: Quick-drying enamel matching topcoat.
 - c. Topcoat: Quick-drying enamel (semi-gloss).

END OF SECTION 099123

SECTION 099123 - INTERIOR PAINTING

PART 1 - GENERAL

1.1 RELATED DOCUMENTS

- A. Drawings and general provisions of the Contract, including General and Supplementary Conditions and Division 01 Specification Sections, apply to this Section.

1.2 SUMMARY

- A. Section includes surface preparation and the application of paint systems on interior substrates. Work shall also include, but not necessarily be limited to:
 - 1. Moisture testing of substrates.
 - 2. Surface preparation of substrates as required for acceptance of paint, including cleaning, small crack repair, patching, caulking, and making good surfaces and areas to the limits defined under MPI Repainting Manual Preparation requirements.
 - 3. Specific pre-treatments noted herein or specified in the MPI Repainting Manual.
 - 4. Sealing / priming surfaces for repainting in accordance with MPI Repainting Manual requirements.
 - 5. Provision of safe and adequate ventilation as required over and above temporary ventilation, where toxic and/or volatile / flammable materials are being used.
- B. Related Requirements:
 - 1. Section 055000 "Metal Fabrications" for shop priming metal fabrications.
 - 2. Section 055319 "Expanded Metal Gratings" for shop priming metal gratings.

1.3 DEFINITIONS

- A. MPI Gloss Level 1: Not more than five units at 60 degrees and 10 units at 85 degrees, according to ASTM D 523.
- B. MPI Gloss Level 2: Not more than 10 units at 60 degrees and 10 to 35 units at 85 degrees, according to ASTM D 523.
- C. MPI Gloss Level 3: 10 to 25 units at 60 degrees and 10 to 35 units at 85 degrees, according to ASTM D 523.
- D. MPI Gloss Level 4: 20 to 35 units at 60 degrees and not less than 35 units at 85 degrees, according to ASTM D 523.
- E. MPI Gloss Level 5: 35 to 70 units at 60 degrees, according to ASTM D 523.

- F. MPI Gloss Level 6: 70 to 85 units at 60 degrees, according to ASTM D 523.
- G. MPI Gloss Level 7: More than 85 units at 60 degrees, according to ASTM D 523.

1.4 ACTION SUBMITTALS

- A. Product Data: For each type of product. Include preparation requirements and application instructions.
 - 1. Include Printout of current "MPI Approved Products List" for each product category specified, with the proposed product highlighted.
 - 2. Indicate VOC content.
- B. Sustainable Design Submittals:
 - 1. Product Data: For paints and coatings, indicating VOC content and chemical components.
 - 2. Laboratory Test Reports: For paints and coatings, indicating compliance with requirements for low-emitting materials.
- C. Samples for Initial Selection: For each type of topcoat product.
- D. Samples for Verification: For each type of paint system and in each color and gloss of topcoat.
 - 1. Submit Samples on rigid backing, 8 inches square.
 - 2. Apply coats on Samples in steps to show each coat required for system.
 - 3. Label each coat of each Sample.
 - 4. Label each Sample for location and application area.
- E. Product List: Cross-reference to paint system and locations of application areas. Use same designations indicated on Drawings and in schedules. Include color designations.

1.5 MAINTENANCE MATERIAL SUBMITTALS

- A. Furnish extra materials, from the same product run, that match products installed and that are packaged with protective covering for storage and identified with labels describing contents.
 - 1. Paint: 5 percent, but not less than 1 gal. of each material and color applied.
- B. Furnish an itemized list complete with manufacturer, paint type, and color coding for all colors used for Owner's later use in maintenance.

1.6 DELIVERY, STORAGE, AND HANDLING

- A. Delivery and Handling: Deliver products to Project site in an undamaged condition in manufacturer's original sealed containers, complete with labels and instructions for

handling, storing, unpacking, protecting, and installing. Packaging shall bear the manufacture's label with the following information:

1. Product name and type (description).
 2. Batch date.
 3. Color number.
 4. VOC content.
 5. Environmental handling requirements.
 6. Surface preparation requirements.
 7. Application instructions.
- B. Store materials not in use in tightly covered containers in well-ventilated areas with ambient temperatures continuously maintained at not less than 45 deg F.
1. Maintain containers in clean condition, free of foreign materials and residue.
 2. Remove rags and waste from storage areas daily.

1.7 FIELD CONDITIONS

- A. Apply paints only when temperature of surfaces to be painted and ambient air temperatures are between 50 and 95 deg F.
- B. Do not apply paints when relative humidity exceeds 85 percent; at temperatures less than 5 deg F above the dew point; or to damp or wet surfaces.
- C. Perform no interior repainting work unless adequate continuous ventilation and sufficient heating facilities are in place to maintain minimum ambient air and substrate temperatures for 24 hours before, during and after paint application. Provide supplemental ventilating and heating equipment if ventilation and heating from existing system is inadequate to meet minimum requirements. Do not use gas fired heating units.
- D. Scheduling
1. Schedule interior repainting operations to prevent disruption of and by other trades when applicable.
 2. Schedule interior repainting operations to prevent disruption of occupants in and about the building. Obtain written authorization from Architect or Owner for changes in work schedule.
 3. Repainting in occupied facilities to be carried out during hours in accordance with Owner's operating requirements such as during silent hours or on weekends. Schedule work such that painted surfaces will have dried before occupants are affected.

PART 2 - PRODUCTS

2.1 MANUFACTURERS

- A. Manufacturers: Subject to compliance with requirements, available manufacturers offering products that may be incorporated into the Work include, but are not limited to the following:
1. Benjamin Moore & Co.
 2. Coronado Paint; Benjamin Moore Company.
 3. PPG Architectural Coatings.
 4. Sherwin-Williams Company (The).
- B. Products: Subject to compliance with requirements, available products that may be incorporated into the Work include, but are not limited to products listed in the Interior Painting Schedule for the paint category indicated.
- C. Source Limitations: Obtain paint materials from single source from single listed manufacturer.

2.2 PAINT, GENERAL

- A. MPI Standards: Products shall comply with MPI standards indicated and shall be listed in its "MPI Approved Products Lists."
- B. Material Compatibility:
1. Materials for use within each paint and coating system shall be compatible with one another and substrates indicated, under conditions of service and application as demonstrated by manufacturer, based on testing and field experience.
 2. For each coat in a paint system, products shall be recommended in writing by topcoat manufacturers for use in paint system and on substrate indicated.
 3. Patching Material Compatibility: Furnish surface preparation products, including patching compounds, that are compatible with selected paint products.
- C. Material Emissions and Pollutant Control: Not less than 85 percent of field-applied paints and coatings that are inside the weatherproofing system shall comply with either of the following:
1. Low-Emitting Materials: VOC emissions shall comply with the requirements of the California Department of Public Health's "Standard Method for the Testing and Evaluation of Volatile Organic Chemical Emissions from Indoor Sources Using Environmental Chambers." Formaldehyde emissions shall not exceed 9 mcg/cu. m or 7 ppb, whichever is less.
 2. VOC content shall not exceed limits of authorities having jurisdiction and the following:
 - a. Flat Coatings: 50 g/L.
 - b. Nonflat Coatings: 100 g/L.

- c. Nonflat - High-Gloss Coatings: 150 g/L.
 - d. Dry-Fog Coatings: 150 g/L.
 - e. Industrial Maintenance Coatings: 250 g/L.
 - f. Pretreatment Wash Primers: 420 g/L.
 - g. Primers, Sealers, and Undercoaters: 100 g/L.
 - h. Recycled Coatings: 250 g/L.
 - i. Rust-Preventive Coatings: 250 g/L.
- D. Chemical Components of Field-Applied Interior Paints and Coatings: Provide topcoat paints and anti-corrosive and anti-rust paints applied to ferrous metals that comply with the following chemical restrictions; these requirements do not apply to paints and coatings that are applied in a fabrication or finishing shop:
- 1. Aromatic Compounds: Paints and coatings shall not contain more than 1.0 percent by weight of total aromatic compounds (hydrocarbon compounds containing one or more benzene rings).
 - 2. Restricted Components: Paints and coatings shall not contain any of the following:
 - a. Acrolein.
 - b. Acrylonitrile.
 - c. Antimony.
 - d. Benzene.
 - e. Butyl benzyl phthalate.
 - f. Cadmium.
 - g. Di (2-ethylhexyl) phthalate.
 - h. Di-n-butyl phthalate.
 - i. Di-n-octyl phthalate.
 - j. 1,2-dichlorobenzene.
 - k. Diethyl phthalate.
 - l. Dimethyl phthalate.
 - m. Ethylbenzene.
 - n. Formaldehyde.
 - o. Hexavalent chromium.
 - p. Isophorone.
 - q. Lead.
 - r. Mercury.
 - s. Methyl ethyl ketone.
 - t. Methyl isobutyl ketone.
 - u. Methylene chloride.
 - v. Naphthalene.
 - w. Toluene (methylbenzene).
 - x. 1,1,1-trichloroethane.
 - y. Vinyl Chloride
- E. Colors: Match Architect's samples or match existing.

2.3 SOURCE QUALITY CONTROL

- A. Testing of Paint Materials: Owner reserves the right to invoke the following procedure:

1. Owner will engage the services of a qualified testing agency to sample paint materials. Contractor will be notified in advance and may be present when samples are taken. If paint materials have already been delivered to Project site, samples may be taken at Project site. Samples will be identified, sealed, and certified by testing agency.
2. Testing agency will perform tests for compliance with product requirements.
3. Owner may direct Contractor to stop applying paints if test results show materials being used do not comply with product requirements. Contractor shall remove noncomplying paint materials from Project site, pay for testing, and repaint surfaces painted with rejected materials. Contractor will be required to remove rejected materials from previously painted surfaces if, on repainting with complying materials, the two paints are incompatible.

PART 3 - EXECUTION

3.1 EXAMINATION

- A. Examine substrates and conditions, with Applicator present, for compliance with requirements for maximum moisture content and other conditions affecting performance of the Work.
- B. Maximum Moisture Content of Substrates: When measured with an electronic moisture meter as follows:
 1. Concrete: 12 percent.
 2. Fiber-Cement Board: 12 percent.
 3. Masonry (Clay and CMUs): 12 percent.
 4. Wood: 15 percent.
 5. Gypsum Board: 12 percent.
 6. Plaster: 12 percent.
- C. Gypsum Board Substrates: Verify that finishing compound is sanded smooth.
- D. Plaster Substrates: Verify that plaster is fully cured.
- E. Verify suitability of substrates, including surface conditions and compatibility, with existing finishes and primers.
- F. Proceed with coating application only after unsatisfactory conditions have been corrected.
 1. Application of coating indicates acceptance of surfaces and conditions.

3.2 PREPARATION

- A. Comply with manufacturer's written instructions and recommendations in "MPI Architectural Painting Specification Manual" applicable to substrates and paint systems indicated.

- B. Remove hardware, covers, plates, and similar items already in place that are removable and are not to be painted. If removal is impractical or impossible because of size or weight of item, provide surface-applied protection before surface preparation and painting.
 - 1. After completing painting operations, use workers skilled in the trades involved to reinstall items that were removed. Remove surface-applied protection if any.
 - 2. Do not paint over labels of independent testing agencies or equipment name, identification, performance rating, or nomenclature plates.
- C. Clean substrates of substances that could impair bond of paints, including dust, dirt, oil, grease, and incompatible paints and encapsulants.
 - 1. Remove incompatible primers and reprime substrate with compatible primers or apply tie coat as required to produce paint systems indicated.
- D. Concrete Substrates: Remove release agents, curing compounds, efflorescence, and chalk. Do not paint surfaces if moisture content or alkalinity of surfaces to be painted exceeds that permitted in manufacturer's written instructions.
- E. Masonry Substrates: Remove efflorescence and chalk. Do not paint surfaces if moisture content or alkalinity of surfaces or mortar joints exceeds that permitted in manufacturer's written instructions.
- F. Steel Substrates: Remove rust, loose mill scale, and shop primer, if any. Clean using methods recommended in writing by paint manufacturer but not less than the following:
 - 1. SSPC-SP 2.
 - 2. SSPC-SP 3.
 - 3. SSPC-SP 7/NACE No. 4.
 - 4. SSPC-SP 11.
- G. Shop-Primed Steel Substrates: Clean field welds, bolted connections, and areas where shop paint is abraded. Paint exposed areas with the same material as used for shop priming to comply with SSPC-PA 1 for touching up shop-primed surfaces.
- H. Galvanized-Metal Substrates: Remove grease and oil residue from galvanized sheet metal by mechanical methods to produce clean, lightly etched surfaces that promote adhesion of subsequently applied paints.
- I. Aluminum Substrates: Remove loose surface oxidation.
- J. Wood Substrates:
 - 1. Scrape and clean knots, and apply coat of knot sealer before applying primer.
 - 2. Sand surfaces that will be exposed to view, and dust off.
 - 3. Prime edges, ends, faces, undersides, and backsides of wood.
 - 4. After priming, fill holes and imperfections in the finish surfaces with putty or plastic wood filler. Sand smooth when dried.

- K. Cotton or Canvas Insulation Covering Substrates: Remove dust, dirt, and other foreign material that might impair bond of paints to substrates.
- L. Mechanical / Electrical Equipment:
 - 1. Unless otherwise noted, repainting shall also include exposed to view / previously painted mechanical and electrical equipment and components (panels, conduits, piping, hangers, ductwork, etc.).
 - 2. Touch up scratches and marks and repaint such mechanical and electrical equipment and components with color, and sheen finish to match existing unless otherwise noted or scheduled.
 - 3. Do not paint over nameplates or instruction labels.
 - 4. Keep repainted sprinkler heads free of paint.
 - 5. Do not paint interior transformers and substation equipment.

3.3 APPLICATION

- A. Apply paints according to manufacturer's written instructions and to recommendations in "MPI Manual."
 - 1. Use applicators and techniques suited for paint and substrate indicated.
 - 2. Paint surfaces behind movable equipment and furniture same as similar exposed surfaces. Before final installation, paint surfaces behind permanently fixed equipment or furniture with prime coat only.
 - 3. Paint front and backsides of access panels, removable or hinged covers, and similar hinged items to match exposed surfaces.
 - 4. Do not paint over labels of independent testing agencies or equipment name, identification, performance rating, or nomenclature plates.
 - 5. Primers specified in painting schedules may be omitted on items that are factory primed or factory finished if acceptable to topcoat manufacturers.
- B. Tint each undercoat a lighter shade to facilitate identification of each coat if multiple coats of same material are to be applied. Tint undercoats to match color of topcoat, but provide sufficient difference in shade of undercoats to distinguish each separate coat.
- C. If undercoats or other conditions show through topcoat, apply additional coats until cured film has a uniform paint finish, color, and appearance.
- D. Apply paints to produce surface films without cloudiness, spotting, holidays, laps, brush marks, roller tracking, runs, sags, ropiness, or other surface imperfections. Cut in sharp lines and color breaks.
- E. Painting Fire Suppression, Plumbing, HVAC, Electrical, Communication, and Electronic Safety and Security Work:
 - 1. Paint the following work where exposed in equipment rooms:
 - a. Uninsulated metal piping.
 - b. Uninsulated plastic piping.
 - c. Pipe hangers and supports.

- d. Metal conduit.
 - e. Plastic conduit.
 - f. Tanks that do not have factory-applied final finishes.
 - g. Duct, equipment, and pipe insulation having cotton or canvas insulation covering or other paintable jacket material.
 - h. Visible portions of internal surfaces of metal ducts, without liner, behind air inlets and outlets.
2. Paint the following work where exposed in occupied spaces:
- a. Equipment, including panelboards that is indicated to have a factory-primed finish for field painting.
 - b. Uninsulated metal piping.
 - c. Uninsulated plastic piping.
 - d. Pipe hangers and supports.
 - e. Metal conduit.
 - f. Plastic conduit.
 - g. Duct, equipment, and pipe insulation having cotton or canvas insulation covering or other paintable jacket material.
 - h. Other items as directed by Architect.
3. Paint portions of internal surfaces of metal ducts, without liner, behind air inlets and outlets that are visible from occupied spaces.

3.4 FIELD QUALITY CONTROL

- A. Dry Film Thickness Testing: Owner may engage the services of a qualified testing and inspecting agency to inspect and test paint for dry film thickness.
1. Contractor shall touch up and restore painted surfaces damaged by testing.
 2. If test results show that dry film thickness of applied paint does not comply with paint manufacturer's written recommendations, Contractor shall pay for testing and apply additional coats as needed to provide dry film thickness that complies with paint manufacturer's written recommendations.
- B. All surfaces, preparation, and paint applications shall be inspected.
- C. Repainted interior surfaces shall be considered to lack uniformity and soundness if any of the following defects are apparent to the Painting Inspection Agency inspector:
1. Brush / roller marks, streaks, laps, runs, sags, drips, heavy stippling, hiding or shadowing by inefficient application methods, skipped or missed areas, and foreign materials in paint coatings.
 2. Evidence of poor coverage at rivet heads, plate edges, lap joints, crevices, pockets, corners and re-entrant angles.
 3. Damage due to touching before paint is sufficiently dry or any other contributory cause.
 4. Damage due to application on moist surfaces or caused by inadequate protection from the weather.

5. Damage and/or contamination of paint due to blown contaminants (dust, spray paint, etc.).
- D. Repainted interior surfaces shall be considered unacceptable if any of the following are evident under final lighting source conditions:
1. Visible defects are evident on vertical surfaces when viewed at 90 degrees to the surface from a distance of 39 inches.
 2. Visible defects are evident on horizontal surfaces when viewed at 45 degrees to the surface from a distance of 39 inches.
 3. Visible defects are evident on ceiling surfaces when viewed at 45 degrees to the surface.
 4. When the final coat on any surface exhibits a lack of uniformity of sheen across full surface area.
- E. Repainted surfaces rejected by the inspector shall be made good at the expense of the Contractor. Small affected areas may be touched up; large affected areas or areas without sufficient dry film thickness of paint shall be repainted. Runs, sags of damaged paint shall be removed by scraper or by sanding prior to application of paint.

3.5 CLEANING AND PROTECTION

- A. At end of each workday, remove rubbish, empty cans, rags, and other discarded materials from Project site.
- B. After completing paint application, clean spattered surfaces. Remove spattered paints by washing, scraping, or other methods. Do not scratch or damage adjacent finished surfaces.
- C. Protect work of other trades against damage from paint application. Correct damage to work of other trades by cleaning, repairing, replacing, and refinishing, as approved by Architect, and leave in an undamaged condition.
- D. At completion of construction activities of other trades, touch up and restore damaged or defaced painted surfaces.
- E. To reduce the amount of contaminants entering waterways, sanitary / storm drain systems or into the ground the following procedures shall be strictly adhered to:
1. Retain cleaning water for water based materials to allow sediments to be filtered out. In no case shall equipment be cleaned using free draining water.
 2. Retain cleaners, thinners, solvents and excess paint and place in designated containers and ensure proper disposal.
 3. Return solvent and oil soaked rags used during painting operations for contaminant recovery, proper disposal, or appropriate cleaning and laundering.
 4. Dispose of contaminants in an approved legal manner in accordance with hazardous waste regulations.
 5. Empty paint cans are to be dry prior to disposal or recycling (where available).

6. Close and seal tightly partly used cans of materials including sealant and adhesive containers and store protected in well ventilated fire safe area at moderate temperature.
- F. Where paint recycling is available, collect waste paint by type and provide for delivery to recycling or collection facility.

3.6 INTERIOR PAINTING SCHEDULE

A. Concrete Substrates, Non-traffic Surfaces:

1. Institutional Low-Odor/VOC Latex System MPI INT 3.1M:
 - a. Prime Coat: Primer sealer, interior, institutional low odor/VOC, MPI #149.
 - b. Intermediate Coat: Latex, interior, institutional low odor/VOC, matching topcoat.
 - c. Topcoat: Latex, interior, institutional low odor/VOC, semi-gloss (MPI Gloss Level 5), MPI #147.
2. Alkyd System MPI INT 3.1D:
 - a. Prime Coat: Primer, alkali resistant, water based, MPI #3.
 - b. Intermediate Coat: Alkyd, interior, matching topcoat.
 - c. Topcoat: Alkyd, interior, gloss (MPI Gloss Level 6), MPI #48.
3. Epoxy System MPI INT 3.1F:
 - a. Prime Coat: Epoxy, matching topcoat.
 - b. Intermediate Coat: Epoxy, matching topcoat.
 - c. Topcoat: Epoxy, gloss, MPI #77.
4. Epoxy, High-Build System MPI INT 3.1P:
 - a. Prime Coat: High-build epoxy, matching topcoat (reduced).
 - b. Intermediate Coat: High-build epoxy, matching topcoat.
 - c. Topcoat: High-build epoxy, gloss, MPI #98.
5. Epoxy-Modified Latex System MPI INT 3.1G:
 - a. Prime Coat: Epoxy-modified latex, matching topcoat.
 - b. Intermediate Coat: Epoxy-modified latex, matching topcoat.
 - c. Topcoat: Epoxy-modified latex, gloss (MPI Gloss Level 6), MPI #115.

B. Concrete Substrates, Traffic Surfaces:

1. Alkyd Floor Enamel System MPI INT 3.2B:
 - a. Prime Coat: Floor enamel, alkyd, matching topcoat.
 - b. Intermediate Coat: Floor enamel, alkyd, matching topcoat.
 - c. Topcoat: Floor enamel, alkyd, gloss (MPI Gloss Level 6), MPI #27.

2. Concrete Stain System MPI INT 3.2E:
 - a. First Coat: Stain, interior, for concrete floors, matching topcoat.
 - b. Topcoat: Stain, interior, for concrete floors, MPI #58.
 3. Solvent-Based Concrete Floor Sealer System MPI INT 3.2F:
 - a. First Coat: Sealer, solvent based, for concrete floors, matching topcoat.
 - b. Topcoat: Sealer, solvent based, for concrete floors, MPI #104.
 4. Epoxy System MPI INT 3.2C:
 - a. Prime Coat: Epoxy, matching topcoat.
 - b. Intermediate Coat: Epoxy, matching topcoat.
 - c. Topcoat: Epoxy, gloss, MPI #77.
 5. Epoxy, High-Build System MPI INT 3.2L:
 - a. Prime Coat: High-build epoxy, matching topcoat (reduced).
 - b. Intermediate Coat: High-build epoxy, matching topcoat.
 - c. Topcoat: High-build epoxy, gloss, MPI #98.
- C. CMU Substrates:
1. Institutional Low-Odor/VOC Latex System MPI INT 4.2E:
 - a. Block Filler: Block filler, latex, interior/exterior, MPI #4.
 - b. Intermediate Coat: Latex, interior, institutional low odor/VOC, matching topcoat.
 - c. Topcoat: Latex, interior, institutional low odor/VOC, semi-gloss (MPI Gloss Level 5), MPI #147.
 2. Alkyd System MPI INT 4.2C:
 - a. Block Filler: Block filler, latex, interior/exterior, MPI #4.
 - b. Sealer Coat: Primer sealer, latex, interior, MPI #50.
 - c. Intermediate Coat: Alkyd, interior, matching topcoat.
 - d. Topcoat: Alkyd, interior, semi-gloss (MPI Gloss Level 5), MPI #47.
 3. Epoxy System MPI INT 4.2G:
 - a. Block Filler: Block filler, epoxy, MPI #116.
 - b. Intermediate Coat: Epoxy, matching topcoat.
 - c. Topcoat: Epoxy, gloss, MPI #77.
 4. Epoxy, High-Build System MPI INT 4.2R:
 - a. Prime Coat: Epoxy block filler, MPI #116.
 - b. Intermediate Coat: High-build epoxy, matching topcoat.
 - c. Topcoat: High-build epoxy, gloss, MPI #98.

D. Steel Substrates:

1. Quick-Dry Enamel System MPI INT 5.1A:
 - a. Prime Coat: Primer, alkyd, quick dry, for metal, MPI #76.
 - b. Intermediate Coat: Alkyd, quick dry, matching topcoat.
 - c. Topcoat: Alkyd, quick dry, semi-gloss (MPI Gloss Level 5), MPI #81.

E. Galvanized-Metal Substrates:

1. Alkyd over Cementitious Primer System MPI INT 5.3C:
 - a. Prime Coat: Primer, galvanized, cementitious, MPI #26.
 - b. Intermediate Coat: Alkyd, interior, matching topcoat.
 - c. Topcoat: Alkyd, interior, semi-gloss (MPI Gloss Level 5), MPI #47.
2. Epoxy over Epoxy Primer System MPI INT 5.3D:
 - a. Prime Coat: Primer, epoxy, anti-corrosive, for metal, MPI #101.
 - b. Intermediate Coat: Epoxy, matching topcoat.
 - c. Topcoat: Epoxy, gloss, MPI #77.

F. Stainless-Steel Substrates:

1. Alkyd System MPI INT 5.6B:
 - a. Prime Coat: Primer, vinyl wash, MPI #80.
 - b. Intermediate Coat: Alkyd, interior, matching topcoat.
 - c. Topcoat: Alkyd, interior, semi-gloss (MPI Gloss Level 5), MPI #47.

G. Cotton or Canvas and ASJ Insulation-Covering Substrates: Including pipe and duct coverings.

1. Alkyd System MPI INT 10.1B:
 - a. Prime Coat: Primer sealer, latex, interior, MPI #50.
 - b. Intermediate Coat: Alkyd, interior, matching topcoat.
 - c. Topcoat: Alkyd, interior, semi-gloss (MPI Gloss Level 5), MPI #47.

END OF SECTION 099123

SECTION 111900 - DETENTION EQUIPMENT GENERAL REQUIREMENTS

PART 1 - GENERAL

1.1 SECTION INCLUDES

- A. Detention Equipment Contractor (DEC) will furnish and install security detention grade products and systems that are consistent with the security requirements of this maximum security facility.
- B. DEC will provide complete operational and functional systems. DEC will provide security detention products and systems as specified, by qualified manufacturers and/or suppliers only.
- C. DEC will furnish all plant and field labor, equipment, appliances, services and materials and perform all work in connection with the installation of detention equipment, complete, in strict accordance with the specifications and the applicable drawings. Section 11190 Work includes Work of the following Sections:
 - 1. Section 111910 – Detention Hollow Metal Door and Frames
 - 2. Section 111920 – Detention Hardware
 - 3. Section 111960 – Security Fasteners
 - 4. Section 111990 – Detention Metal Panel Wall Systems

1.2 COORDINATION AND MANAGEMENT WITH WORK TO BE PERFORMED UNDER OTHER SECTIONS:

- A. DEC will coordinate, manage and be responsible for and between detention hollow metal, and detention hardware Work in the following manner:
 - 1. Detention Equipment Contractor (DEC) Responsibilities:
 - a. Furnish and install door locks, door position switches, limit switches, lock feature switches and pushbuttons, as required for the system to perform the functions as defined in Division 11 and related Sections.
 - b. After installation, adjust all locks and switches for proper mechanical alignment.

1.3 RELATED DOCUMENTS

- A. Drawings and provisions of the Contract include General Conditions, Supplementary General Conditions and Requirements applicable to the referenced Sections.

1.4 RELATED SECTIONS

- A. Division 5 Section - Metal Fabrications.
- B. Division 7 Section –Joint Sealants.

C. Division 9 Section - Painting

1.5 DEFINITIONS

- A. DEC: Detention Equipment Contractor (DEC), specialty contractor defined in this Section.

1.6 QUALITY ASSURANCE

- A. Perform the work of this Section with a single DEC. DEC shall have responsibility for the following:

1. Coordinating, furnishing and installing all items of detention equipment.
2. Furnish to the General Contractor(s) those items to be embedded into adjacent materials, including security hollow metal frame embeds and necessary anchorage devices of all types; these items shall be installed by the General Contractor(s).
3. Instruct General Contractor(s) as to correct installation methods, adhering to specified requirements and construction document details.
4. When installation of embeds and detention hollow metal frame embeds is complete and acceptable, DEC shall approve installation in writing, transmitting copy of letter to the Architect and Owner.
5. Perform final field installation of security hollow metal doors and security hardware.

- B. The following Detention Equipment Contractors (DEC) have been pre-approved to bid on this project. Other Detention Equipment Contractors desiring to submit bids on the project must comply with paragraph 1.6.C, below.

1. Norment Security Group, 3224 Mobile Highway, Montgomery, Alabama 36108-4400, Phone: (334) 281-8440, Fax: (334) 288-5485, <http://www.normentsecurity.com>
2. Cornerstone Detention Products, Inc., 25270 Will McComb Drive, Tanner, AL 35671, Phone: (256) 355-2396, Fax: (256) 560-4284, <http://www.CornerstoneDetention.com>
3. CCC Group, Inc., P.O. Box 200350, San Antonio, TX 78220, Phone: (210) 410-0415, Fax: (210) 662-1643, <http://www.cccgrouping.com>
4. Southern Folger Company, 4634 S. Presa Street, San Antonio, TX 78223, Phone: (210) 533-1231, Fax: (210) 533-2211, <http://www.southernsteel.com>
5. CML Specialties, Inc. 1100 E. Lakeshore Dr., Coeur D'Alene ID 83814, Phone: 208/765-2415, Fax: 208/765-0590, email: tdavis@cmlspecialties.com
6. Sierra Detention Systems, 15820 W. 6th Ave, Golden, CO 80401, Phone:

303/278-6879, Fax: 303/278-6921, web: www.sierrasteel-dec.com, e-mail: rpilcher@sierrasteel-dec.com

7. Legg, Inc., 2551 2nd St., Livermore, CA 94550, Phone: (925) 605-4500, Fax: (925) 605-4510, web: www.legginc.com

C. Detention Equipment Contractors (DEC) interested in bidding this project shall submit the following data with their bid. Failure to include all required information below; will be grounds for considering a bid as non-responsive.

1. Evidence of a minimum of 5 years of experience in successfully completing projects of equal or greater size and magnitude. This evidence shall consist of a list of 5 new detention or corrections projects of at least 200 cells (beds) configured in either single or double occupancy or dormitory, completed and operational for a minimum of 2 years. Experience shall be for the DEC as a legal entity only. Experience of individuals employed by the DEC who were previously employed by another DEC entity, shall not be used to establish the respondent entity's level of experience.
2. For each project listed, include name and location of the facility, number of cells, rated bed capacity, value of the overall construction contract, value of the DEC's contract, date of occupancy by the Owner, and the name, address and telephone number of the Owner's Representative, Architect, Construction Manager, and/or General Contractor.
3. Name and address of the respondent DEC. Identify whether the respondent firm is a sole legal entity or is a subsidiary of a parent company, and identify the parent company.
4. Provide statement indicating DEC has not filed for bankruptcy protection within the past ten (10) years.
5. Submit a statement letter from the Surety Company (that has an AM Best AA15 rating) stating that a 100% Payment and Performance bond will be supplied if selected as the successful Detention Equipment Contractor (DEC). Letters from bonding agents are not acceptable.
6. Name, title, resume, and employment date of the project management team for the respondent DEC. The project management team shall, at a minimum, include the principal-in-charge, project manager, project engineer, and the site-based project superintendent.
7. Submit an original letter from the Section 111920 lock manufacturer stating that the firm is a certified, factory-trained installer of the complete line of detention products. Letter shall include the name or names of the firm's individual employees who have been certified by the lock manufacturer and state that they will be assigned to this project and be on-site, full-time during the entire installation and conduct the owner training sessions as specified.
8. The successful DEC shall assign the site-based project superintendent with a minimum of 10-years of documented detention experience to the construction site on a permanent basis upon initiation of the installation of its Work, and will remain permanently assigned to the construction site until all punch list items are completed. The Owner may, at their option and upon written request of the DEC, approve the replacement of the site-based project superintendent due only to circumstances beyond the control of the DEC.
9. Submit an original letter certifying that the DEC will have on-site a factory

technician who shall oversee the completed installation, adjustments and testing, of locks and sliding devices. The factory technician shall also conduct the owner training sessions specified.

10. List the appropriate contractor's license classification and number.
11. All submittal requirements as stated above shall apply to a single legal entity responding as the DEC. Responses from joint ventures, associations or any teaming efforts will be considered only if each legal entity of the joint venture, association, or teaming effort fully complies with the submittal requirements as stated above.

1.7 REGULATORY REQUIREMENTS

- A. General: Comply with applicable requirements of the California Building Code.
- B. Door Openings and Hardware: Comply with requirements of applicable Code for requirements of fire rated doors and frames, and sections of Chapter 5 of NFPA 101 and NFPA 80.

1.8 SUBMITTALS

- A. General: Comply with requirements of Division 1. Refer to specific requirements in specification Sections identified in related specification sections listed in this section.

1.9 SHOP DRAWING REVIEW SESSION:

- A. DEC will provide a draft of the Detention Hollow Metal shop drawings and the Detention Hardware Schedule within one (1) week of receipt of their "Notice to Proceed". The draft will be reviewed for compliance with the requirements of the specification sections. The Shop Drawing Review Session will be scheduled within two (2) weeks after acceptance of the draft for compliance.
- C. Upon completion of the Submittal process an architectural representative and the DEC will both signify their approval of the submittals by signature of both the hollow metal and hardware submittals. Such sign off will signify concurrence that the submittals have been fully coordinated and will result in a complete installation.
- D. The rationale of the Shop Drawing Review Session is to expedite the approval process and delivery of detention hollow metal frames to the project site. Any effort to circumvent any portion of this Shop Drawing Review Session will not be tolerated.

1.10 DELIVERY, STORAGE, AND PROTECTION

- A. Responsibility of the General Contractor: Receive from carrier, unload and store all material which is furnished by the DEC and installed by others.
- B. General Contractor shall provide temporary access openings required through walls to permit the placing of the detention equipment in the areas of the building where it is to be installed and provide use of hoist, cranes, elevators and lifts and/or cranes on regular time with qualified operators.

- C. Protect all materials during storage on the job and after installation. All protection required while working and/or cleaning adjacent materials shall be the responsibility of the DEC.
- D. Provide adequate, secure, dry, lockable storage area for all materials specified in this Section.
- E. The DEC shall be responsible for receiving, unloading and distribution of all products furnished and installed by the DEC.

1.11 TRAINING AND SERVICING OF SECURITY HARDWARE

- A. During the check-out phase of construction between the DEC, the Owner will provide one (1) or two (2) of their staff to participate in the check-out interface for a period of one-half (1/2) day. This participation is not intended to have the Owner's staff to do the work, but to learn the correction techniques of the DEC.
- B. Prior to acceptance of the work arrange for training programs to be conducted for the Owner in maintenance and servicing of commercial and detention hardware. Programs shall be presented at a time and location agreeable to the Owner and his representatives. All programs shall be professionally video taped and the Owner provided with 2 copies of videos.
- C. Programs in training and servicing shall be conducted by qualified persons knowledgeable with the products installed, and may consist of personnel from manufacturers or their representative, suppliers or distributors.
- D. In addition to other specified requirements, approximately 6 months following Final Acceptance of the Work, arrange to have installer of detention hardware, representatives from the builders hardware, to contact Owner and make arrangements for an inspection of the hardware, time and date of the inspection at the Owner's convenience. Readjust all hardware for proper and smooth operation; consult with Owner's personnel pertaining to any additional maintenance procedures that may be required; clean and lubricate hardware as required; replace any hardware which has deteriorated due to faulty design, materials or installation. Submit written report of current and predictable problems of any substantial nature in the performance of the hardware to the Owner.

1.12 WARRANTY

- A. General: Comply with requirements of Division 1.
- B. The DEC warrants materials furnished and installed under this Section to be free from defects in materials and workmanship for a period for two years, effective from the date of Substantial Completion of this project. Warranty to include material replacement at no cost to Owner, inclusive of labor to remove, install, and repaint defective as determined by the Owner, during the warranty period. Material which has been misused, abused or neglected by the Owner, defects for damage caused by work or failure of work by others; ordinary wear and tear; or normal equipment adjustment which are within the Owner's operation and maintenance responsibility

will not be covered by the warranty.

PART 2 - PRODUCTS (See Individual Sections)

2.1 MANUFACTURERS

- A. Utilize only listed approved manufacturers, component fabricators and suppliers. Any other manufacturer, component fabricator or supplier must be approved by addenda seven (7) days prior to bid date. Manufacturer, component fabricator or supplier and product substitution requests must be submitted fourteen (14) days prior to bid date. Substitution requests received thirteen (13) days prior to bid date and thereafter, including the Contract Duration period, are not permitted and will be returned without response.

PART 3 - EXECUTION

3.1 EXAMINATION

- A. Examine the areas and conditions under which installation is to occur and document conditions detrimental to the proper and timely completion of the work. Installation should not proceed until unsatisfactory conditions have been corrected.
- B. Prior to installation, meet at project site for purpose of reviewing products and installation methods selected, procedures to be followed in performing the work and coordination.
- C. Protect adjacent surfaces while installing products against damage and stains.
- D. Ascertain location and arrangement of anchorage required to accommodate work; coordinate with other trades to make provisions for installation.

3.2 PREPARATION

- A. Furnish setting drawings, diagrams, templates, instructions and directions for installation of all products. Coordinate delivery of such products to project site.
- B. Distribute all items to installation locations immediately prior to installation, complying with all applicable product handling requirements. Coordinate timing of distribution.
- C. Coordinate with other trades for proper location of rough-in services and service connections specified elsewhere.

3.3 INSTALLATION

- A. The DEC shall be responsible for the integration, interfacing and coordination of all products and systems with other related parties as hereinafter defined and specified.
 - 1. Securely place products in locations required.

2. Install in alignment, free from warp, twist or distortion, plumb, level and true.
3. Comply with approved shop drawings, manufacturer's written instructions and recommendations for both handling and installation of the products for particular conditions of installation in each case, except where more stringent requirements are indicated or specified, or where project conditions require extra precautions or provisions for satisfactory performance of work. Where printed instructions are not available or do not apply to project conditions, consult manufacturer's technical representative for specific recommendations before proceeding. Do not install products which are observed to be defective.
4. Perform cutting, drilling and fitting required for installation of detention equipment.
5. Set work accurately in location, alignment and elevation, measured from established lines and levels with lines visually parallel.
6. Cut necessary holes for installation or other work in detention equipment; comply with templates or detail drawings furnished by other trades prior to fabrication and installation of detention work.
7. Comply with AWS Code for procedures of manual shielded metal-arc welding, appearance and quality of welds made, and methods used in correcting welding work.
 - a. Exposed plug welds shall be 1/4 inch minimum at 3/8-inch diameter holes equally and uniformly spaced over each frame, evenly spaced not greater than 10 inches on center.
 - b. Exposed fillet (stitch) welds shall be 1/8-inch minimum, 1-1/2-inches long (minimum length) evenly spaced not greater than 10 inches on center. Exposed to view welds that occur at frame corners and at door frames shall start no further than 3 inches above sills and corners.
 - c. Where surfaces are exposed to view, grind and sand welds smooth; fill all weld voids, seams, holes, non-welded spaces between welds, imperfections, and blemishes with polyester mineral filler "Bondo" per Section 111910 so surfaces will be uniform, smooth, without indication where welds are located, prior to field finish painting.
8. Field welding or other field attachment of metal assemblies to embedded anchorages shall be accomplished by DEC. Where adjustable anchors are required, furnish anchors to frame installers for setting. Provide grout hole openings complete with plugs. Concrete unit masonry provider shall grout frames set into concrete block, including intermediate mullions or tubular elements (provide grouting and curing instructions). Weld grout hole plugs and provide smooth condition ready for field finish painting.

3.4 ADJUSTMENT, REPAIRING

- A. Before final connections to electrical power are made, test all electrically operating or sensing items and adjust as required to provide proper functions. Test electrically controlled doors utilizing the control consoles under normal operating procedures.
- B. Adjust and lubricate moving parts to operate smoothly and quietly, without binding.
- C. Work shall be free from scratches, dents, permanent discolorations and other defects; remove and replace damaged parts, surfaces with imperfections or damage

during installation or thereafter before time of final project acceptance. Prior to touch-up painting, remove foreign material from metal surfaces including connections. Touch-up welds, bolted connections, and all abraded/damaged areas with shop applied metal primer paint.

3.5 PROTECTION, CLEANING

- A. Comply with Division 1 requirements.
- B. During installation, protect adjacent surfaces and detention equipment from damage.
- C. Work shall be free from scratches, dents, permanent discolorations and other defects; remove and replace damaged parts and surfaces with imperfections before time of final project acceptance.
- D. During installation, maintain storage and work area, and installation locations, in neat, orderly, broom clean condition.
- E. Remove all non-permanent labels, non-permanent protective coatings and identifying marks, and thoroughly clean all surfaces, including concealed work. Remove foreign materials prior to inspections for project closeout.
- F. DEC shall advise General Contractor(s) of required procedures for protection of complete detention work. Advice shall extend through period of installation of other work near detention work, and also through remainder of construction period, for the purpose of assurance that detention equipment will not be damaged.

3.6 DEMONSTRATION, OPERATING INSTRUCTIONS AND TRAINING

- A. The objective of the provided operating/maintenance manuals, training materials and instruction period shall be to communicate a total understanding of operations and maintenance of all detention equipment included in the work. Submit proposed operating/maintenance materials and training materials for review, comment and approval by the Architect and Owner 180 days prior to Substantial Completion. Coordinate with Owner to review materials and instruction periods, to assure Owner instruction and information requirements will be met. Obtain approval prior to scheduling training session.

3.7 ON-SITE TRAINING

- A. Provide representative(s) to Owner who is knowledgeable in operation of detention equipment, and who has thorough knowledge of its mechanisms and operation, for an on-site instruction and training period involving Owner's designated personnel. Representative must be capable of training personnel in the adjustment and operation of detention equipment including pertinent safety requirements, and instructing maintenance personnel in its operation, repair and upkeep. Instruction shall be given during the first week after the system has been accepted and turned over to the Owner for regular operation, except if detention equipment adjustment and/or repairs are required for its use. In such case, training sessions are not to

occur until such adjustments and/or repairs have been satisfactorily completed.

- B. On-site instruction and training period will not exceed one (1) four (4) hour days.

3.8 FIELD QUALITY CONTROL

- A. **Manufacturer's Field Service:** Representatives of the detention equipment manufacturers shall make inspections prior to start of installation, during installation and upon completion of installation to ascertain that the entire system(s) has been installed according to manufacturer's specifications and approved details.

END OF SECTION 111900

SECTION 111910 - DETENTION STEEL DOORS AND FRAMES

PART 1 - GENERAL

1.1 RELATED DOCUMENTS.

- A. Drawings and provisions of the Contract, including General and Supplementary Conditions and Division 01 Specification Sections, apply to this Section.

1.2 SUMMARY

- A. The Work of this Section shall be performed by the DEC utilizing a qualified Detention Hollow Metal Manufacturer.
- B. Section Includes: Detention type, non-fire-rated and fire-rated detention, swinging steel doors, panels, frames, and assemblies inclusive of electrical conduit, electrical back boxes, grout boxes, security fastener grout guards and machine type security fasteners.
- C. Related Requirements:
 - 1. Section 111900 "Detention Equipment General Requirements" for general requirements for detention facilities, including responsibilities of a Detention Specialist.
 - 2. Section 111920 "Detention Hardware" for door hardware for detention doors.

1.3 DEFINITIONS

- A. DEC: Detention Equipment Contractor (DEC).
- B. Minimum-Thickness Steel: Indicated as the specified minimum thicknesses for base metal without coatings, according to NAAMM-HMMA 803.
- C. Nominal-Thickness Stainless Steel: Indicated as the specified thicknesses for which over- and under-thickness tolerances apply, according to ASTM A 480/A 480M.

1.4 QUALITY ASSURANCE

- A. General: The Work of this Section shall be performed by a qualified DEC, Detention Equipment Contractor, in conjunction with an approved Hollow Metal Door and Frame Manufacturer.

1.5 PERFORMANCE TESTS

- A. Certification: Provide a currently independent testing laboratory report and certification in compliance with ASTM F1450 and NAAMM HMMA 863, paragraph 1.06, D; HMMA 863, paragraph 1.06, E, certifying minimum performance data for manufacturer's production maximum security door panels, frames and hardware as

specified and indicated. Certification test reports and documentation shall be in accordance with ASTM F 1450.

1. Destructive Test: Architect may request in writing, additional proof of manufacturer's compliance to meet fabrication standards.
- B. Fire-Rated Assemblies: Complying with NFPA 80 and listed and labeled by a qualified testing agency acceptable to authorities having jurisdiction for fire-protection ratings and temperature-rise limits indicated, based on testing at positive pressure according to NFPA 252, UL 10B and ASTM E152.
1. Smoke- and Draft-Control Assemblies: Provide an assembly with gaskets listed and labeled for smoke and draft control by a qualified testing agency acceptable to authorities having jurisdiction, based on testing according to UL 1784 and installed in compliance with NFPA 105.
 2. Oversize Fire-Rated Assemblies: For units exceeding sizes of tested assemblies, provide certification by a qualified testing agency that doors comply with standard construction requirements for tested and labeled fire-rated door assemblies except for size. Comply with NFPA 252, UL 10B and ASTM E 152 for fabrication of door panels, panels, and frames and NFPA 80 for fire-rated class installations.

1.6 ACTION SUBMITTALS

- A. General: Submit in accordance with Division 1 Section: Submittals.
- B. DEC shall prepare a single coordinated submittal for review that clearly indicates frame type and manufacturers name for each frame type used. Multiple submittals will not be accepted.
- C. Product Data: For each type of product.
1. Include construction details, material descriptions, core descriptions, label compliance, fire-resistance rating, and finishes for each detention door and frame type specified.
- D. LEED Submittals:
1. Product Data for Credit MR 4: For products having recycled content, documentation indicating percentages by weight of postconsumer and preconsumer recycled content. Include statement indicating cost for each product having recycled content.
 2. Product Data for Credit IEQ 4.1: For sealants, documentation including printed statement of VOC content.
- E. Shop Drawings: In addition to requirements below, provide a schedule using same reference numbers for details and openings as those on Drawings:
1. Elevations of each door type.
 2. Direction of swing.

3. Details of doors, including vertical and horizontal edge details, and metal thicknesses.
4. Details of frames, including dimensioned profiles, and metal thicknesses.
5. Locations of reinforcement and preparations for hardware.
6. Details of each different wall opening condition.
7. Details of anchorages, joints, field splices, and connections.
8. Details of moldings, removable stops, and glazing.
9. Details of conduits, junction boxes, and preparations for electrically operated door hardware.

1.7 INFORMATIONAL SUBMITTALS

- A. Manufacturer's Certificate of Quality Assurance and Templates.
- B. Qualification Data: For Installer.
- C. Welding certificates.
- D. Product Test Reports: For each type of detention hollow-metal door and frame assembly including vision and side lights, for tests performed by manufacturer and witnessed by a qualified testing agency.
- E. Examination reports documenting inspection of substrates, areas, and conditions.
- F. Anchor inspection reports documenting inspections of built-in and cast-in anchors.
- G. Field quality-control reports documenting inspections of installed products.
- H. Field quality-control certification signed by Contractor and Detention Specialist.
- I. Oversize Construction Certification: For assemblies required to be fire rated and exceeding limitations of labeled assemblies.

1.8 MAINTENANCE MATERIAL SUBMITTALS

- A. Furnish extra materials that match products installed and that are packaged with protective covering for storage and identified with labels describing contents.
 1. Security Fasteners: Furnish not less than one box for every 50 boxes or fraction thereof, of each type and size of security fastener installed.
 2. Tools: Provide two sets of tools for installing and removing security fasteners.

1.9 DELIVERY, STORAGE, AND PROTECTION

- A. General: Follow recommendations of HMMA 863, Article 3.01 "Site Storage and Protection of Materials" and meeting requirements of this Section. Protect doors and frames with resilient packaging, sealed with heat shrunk plastic. Break seal on-site to permit ventilation.

1.10 COORDINATION

- A. Coordinate anchorage installation for detention frames. Furnish setting drawings, templates, and directions for installing anchorages, including sleeves, concrete inserts, anchor bolts, and items with integral anchors that are to be embedded in adjacent construction. Deliver such items to Project site in time for installation.

1.11 PREINSTALLATION MEETINGS

- A. Preinstallation Conference: Conduct conference at Project site.

1.12 WARRANTY

- A. Provide Manufacturer's 2-year warranty, effective from the date of Substantial Completion of this project.

PART 2 - PRODUCTS

2.1 ACCEPTABLE MANUFACTURERS

- A. Detention Hollow Metal (DHM) Doors and Frames: Subject to compliance with specified requirements, provide products from one or more of the following manufacturers:
 - 1. Chief Industries, Inc.
 - 2. Habersham Metals Products Company.
 - 3. Trussbilt, Inc.
- B. Other Product Manufacturers: Other product manufacturers requesting approval for this project shall comply with Division 1 Section: Substitutions.
 - 1. Submit data required in Section 111990 paragraph 1.6 Quality Assurance, subparagraph 1.6.C.1., 1.6.C.2., 1.6.C.3., 1.6.C.4. and 1.6.C.6.
- C. Source Limitations: Obtain detention doors and frames from single source from single manufacturer.

2.2 MATERIALS

- A. Steel: Commercial quality level sheet.
- B. Recycled Content of Steel Products: Postconsumer recycled content plus one-half of preconsumer recycled content not less than 25 percent.
- C. Detention Door and Frame Assemblies: Provide detention door and frame assemblies that comply with the following, based on testing manufacturer's standard units in assemblies similar to those indicated for this Project:
 - 1. Security Grade: Assemblies pass testing requirements in ASTM F 1450 for

- security grades specified.
 - 2. Bullet Resistance: Level 3 rated when tested according to UL 752.
 - 3. Tool-Attack Resistance: Small-tool-attack-resistance rated when tested according to UL 437 and UL 1034.
- D. Detention Frames: Provide sidelight and borrowed-light detention frames that comply with ASTM F 1592 and removable stop test according to NAAMM-HMMA 863, based on testing manufacturer's standard units in assemblies similar to those indicated for this Project.

2.3 DETENTION DOORS

- A. General: Provide flush-design detention doors of seamless hollow construction, 2 inches thick unless otherwise indicated. Construct detention doors with smooth, flush surfaces without visible joints or seams on exposed faces or stile edges.
- 1. For single-acting swinging detention doors, bevel both vertical edges 1/8 inch in 2 inches.
- B. Core Construction: Provide the following core construction of same material as detention door face sheets, welded to both detention door faces:
- 1. Steel-Stiffened Core: 0.042-inch- thick, steel vertical stiffeners extending full-door height, with vertical webs spaced not more than 4 inches apart, spot welded to face sheets a maximum of 3 inches o.c. Fill spaces between stiffeners with insulation.
 - 2. Truss-Stiffened Core: 0.013-inch- thick, steel, truncated triangular stiffeners extending between face sheets and for full height and width of door; with stiffeners welded to face sheets not more than 3 inches o.c. vertically and 2-3/4 inches horizontally. Fill spaces between stiffeners with insulation.
- C. Vertical Edge Channels: 0.123-inch- thick, continuous channel of same material as detention door face sheets, extending full-door height at each vertical edge; welded to top and bottom channels to create a fully welded perimeter channel. Noncontiguous channel is permitted to accommodate lock-edge hardware only if lock reinforcement is welded to and made integral with channel.
- D. Top and Bottom Channels: 0.123-inch- thick metal channel of same material as detention door face sheets, spot welded, not more than 4 inches o.c., to face sheets.
- 1. Reinforce top edge of detention door with 0.053-inch- thick closing channel, welded so channel web is flush with top door edges.
- E. Hardware Reinforcement: Fabricate reinforcing plates from same material as detention door face sheets to comply with the following minimum thicknesses:
- 1. Full-Mortise Hinges and Pivots: 0.187 inch thick.
 - 2. Maximum-Security Surface Hinges: 0.250 inch thick.
 - 3. Strike Reinforcements: 0.187 inch thick.
 - 4. Slide-Device Hanger Attachments: As recommended by device

- manufacturer.
5. Lock Fronts, Concealed Holders, and Surface-Mounted Closers: 0.093 inch thick.
 6. All Other Surface-Mounted Hardware: 0.093 inch thick.
 7. Lock Pockets: 0.123 inch thick at non-inmate side, welded to face sheet.
- F. Hardware Enclosures: Provide enclosures and junction boxes for electrically operated detention door hardware of same material as detention door face sheets, interconnected with UL-approved, 1/2-inch- diameter conduit and connectors.
1. Access Plates: Where indicated for wiring installation, provide access plates to junction boxes, fabricated from same material and thickness as face sheet and fastened with at least four security fasteners spaced not more than 6 inches o.c.
- G. Interior Detention Doors: Construct interior doors to comply with materials, fabrication, hardware locations, hardware reinforcement, tolerances, and clearances indicated in NAAMM-HMMA 863 and as specified.
1. Security Grade 1: Provide doors with face sheets of 0.093-inch- minimum-thickness, cold-rolled steel OR 0.093-inch- minimum-thickness, metallic-coated, cold-rolled steel OR 0.109-inch nominal-thickness stainless steel.

2.4 DETENTION FRAMES

- A. General: Follow recommendations of HMMA 863, Article 2.03 "Hollow Metal Frames" and meeting requirements of this Section. Fabricate detention frames from the materials as scheduled and indicated.
1. Hardware Reinforcement: Steel plate, size as indicated.
 2. Frame Accessories: Glazing Stops and other accessory items such as speaking devices, gun ports, key pass, tray pass, and related security/detention devices as indicated or scheduled.
- B. Interior Detention Frames: Construct interior frames to comply with materials, fabrication, hardware locations, hardware reinforcement, tolerances, and clearances indicated in NAAMM-HMMA 863 and as specified.
1. Security Grade 1: Provide frames fabricated from 0.093-inch- minimum-thickness, cold-rolled steel OR 0.093-inch- minimum-thickness, metallic-coated, cold-rolled steel OR 0.109-inch nominal-thickness stainless steel.
- C. Fire Rated Frames: Labeled frames shall be provided for those openings requiring fire protection ratings as indicated and scheduled.
- D. Hardware Reinforcement: Fabricate reinforcing plates from same material as detention frame to comply with the following minimum thicknesses:
1. Hinges and Pivots: 0.187 inch thick by 1-1/2 inches wide by 10 inches long.
 2. Strikes, Flush Bolts, and Closers: 0.187 inch thick.

3. Surface-Mounted Hardware: 0.093 inch thick.
 4. Lock Pockets: 0.123 inch thick at non-inmate side, welded to face sheet. Provide 0.123-inch- thick, lock protection plate for attachment to lock pocket with security fasteners.
- E. Hardware Enclosures: Provide enclosures and junction boxes for electrically operated detention door hardware, interconnected with UL-approved, 1/2-inch-diameter conduit and connectors.
1. Access Plates: Where indicated for wiring installation, provide access plates to junction boxes, fabricated from same material and thickness as face sheet and fastened with at least four security fasteners spaced not more than 6 inches o.c.
- F. Mullions and Transom Bars: Provide closed or tubular mullions and transom bars where indicated. Fasten mullions and transom bars at crossings and to jambs by butt welding. Reinforce joints between detention frame members with concealed clip angles or sleeves of same metal and thickness as detention frame.
- G. Jamb Anchors: Weld jamb anchors to detention frames near hinges and directly opposite on strike jamb or as required to secure detention frames to adjacent construction.
1. Number of Anchors: Provide two anchors per jamb plus the following:
 - a. Detention Door Frames: One additional anchor for each 18 inches, or fraction thereof, above 54 inches in height.
 - b. Detention Frames with Security Glazing or Detention Panels: One additional anchor for each 18 inches, or fraction thereof, above 36 inches in height.
 2. Masonry Anchors: Adjustable, corrugated or perforated, strap-and-stirrup anchors to suit detention frame size; formed of same material and thickness as detention frame; with strap not less than 2 inches wide by 10 inches long.
 3. Embedded Anchors: Provide detention frames with removable faces at jambs where embedded anchors are indicated. Anchors consist of the following three parts:
 - a. Embedded Plates: Steel plates, 0.188 inch thick by 4 inches wide by 6 inches long. Continuously weld two steel bars, 1/2 inch in diameter and 10 inches long with 2-inch 90-degree turndown on ends, to the embedded end of each plate. Weld steel angles, 0.188 inch thick by 2 by 2 by 4 inches long, to the exposed end of each plate. Embed at locations to match frame angles.
 - b. Frame Angles: Steel angles, 0.188 inch thick by 2 by 2 by 4 inches long, welded to detention frames with 1-inch- long welds at each end of angle.
 - c. Connector Angles: Steel angles, of size required, to connect frame angles and embedded plates.
 4. Postinstalled Anchors: Minimum 1/2-inch- diameter concealed bolts with expansion shields or inserts. Provide conduit spacer from detention frame to wall, welded to detention frame. Reinforce detention frames at anchor

locations.

- H. Floor Anchors: Provide floor anchors for each jamb and mullion that extends to floor, formed of same material and thickness as detention frame, and as follows:
 - 1. Monolithic Concrete Slabs: Clip anchors, with two holes to receive fasteners, welded to bottom of jambs and mullions with at least four spot welds per anchor.
 - 2. Separate Topping Concrete Slabs: Adjustable anchors with extension clips, allowing not less than 2-inch height adjustment, welded to jambs and mullions with at least four spot welds per anchor. Terminate bottom of detention frames at finish floor surface.
- I. Rubber Door Silencers: Except on weather-stripped detention doors, drill stops in strike jambs to receive three silencers on single-detention-door frames and drill head jamb stop to receive two silencers on double-detention-door frames. Keep holes clear during construction.
- J. Grout Guards: Provide factory-installed grout guards of same material as detention frame, welded to detention frame at back of hardware cutouts, silencers, and glazing-stop screw preparations to close off interior of openings and prevent mortar or other materials from obstructing hardware operation or installation.

2.5 DETENTION GRADE ACCESS DOORS AND FRAMES

- A. Doors: Follow recommendations of HMMA 863, Article 2.01 "Hollow Metal Doors" and meeting requirements of this Section for detention steel doors.
- B. Frames: Follow recommendations of HMMA 863, Article 2.03 "Hollow Metal Frames" and meeting requirements of this Section for detention steel frames.

2.6 FABRICATION

- A. General: Comply with requirements of ANSI/NAAMM HMMA 863.
- B. Detention Doors and Access Doors:
 - 1. Door Pull: Flush within door construction by door manufacturer or as scheduled to receive a raised door pull.
 - 2. Security Locks: Provide special pocket built into door.
 - 3. Detention side of door: 1/8-inch channel welded flush to door face sheets, 3 inches on-center. Cut channel only for passage of lock bolt.
 - 4. Fasten lock to removable, flush lock cover protection plate fabricated from 3/16-inch steel with four security type bolts.
 - 5. Deburr and fasten flush cover plate to door with pin type, internal socket, flat head, security screws per Section 111960.
 - 6. Flush finish cover plate to match door finish. Non-flush cover plate not acceptable.
 - 7. Factory install the following door hardware and security equipment:

8. Electrical conduit and required junction boxes to be located in frame.
9. Factory or field install the following door hardware and security equipment:
10. Security locks and deadbolts, flush pulls, push plates, hangers, door guides, kick plates, key escutcheons, head and foot bolts, food pass doors and food pass locks.
11. When items are not supplied by door manufacturer, DEC shall provide item to door manufacture for installation by the door manufacturer.
12. Factory fabricate boxes, conduit, wiring, and tubing to receive control connections such as limit switches, and/or remote controlled locks, as may be required for doors and pairs of doors.
13. Non-factory installed hardware and related detention equipment when indicated on approved shop drawings may be field installed by the DEC.

C. Detention Frames and Access Frames:

1. Butting of stops not permitted.
2. Fully welded detention frames with integral stops, of seamless construction without visible joints or seams. Fabricate detention frames with contact edges closed tight and corners mitered, reinforced, and continuously welded full depth and width of detention frame.
3. Drilling and tapping of frames for surface hinges shall be by DEC after door is fitted plumb and true into frame.

2.7 FINISHES

- A. General: comply with NAAMM Metal Finishes Manual relative to applying and designating finishes. Clean, treat and paint exposed surfaces of steel doors and frames, including galvanized surfaces, but excluding stainless-steel surfaces.
- B. Dissimilar Metal Protection and Metal to Concrete/Mortar Protection: Provide one of isolation materials for fabricated and installed products acceptable to the manufacturer:
- C. Steel Sheet Finishes: Solvent-clean surfaces to comply with SSPC-SP1 to remove dirt, oil, grease and other foreign matter that could impair paint bond. Remove mill scale and rust, if present, from uncoated steel to comply with SSPC-SP 5 or SSPCSP 8. Immediately after surface preparation, apply conversion coating of type suited for top coating to be applied.

2.8 ACCESSORIES

- A. Polyester Filler: Two part, catalytic, mineral filled, for use in smoothing and filling holes and weld voids in metal surfaces of interior fabrications.
- B. Acceptable Product: Devcon Corp., Danvers, MA.

PART 3 - EXECUTION

3.1 VERIFICATION

- A. Do not begin factory fabrication until glass, glazing, and stop details have been verified in writing for each glass, glazing material. Field measure all site openings and submit measured opening document and verification requirement with shop drawing submittal as indicated above.

3.2 INSTALLATION

- A. Follow recommendations of HMMA 863, Article 3.02 "Installation" and meeting requirements of this Section.

3.3 TOLERANCES

- A. General: Follow recommendations of HMMA 863, Article 2.04 "Clearances and Tolerances" and meeting requirements of this Section.

3.4 ADJUSTING AND CLEANING

- A. Adjust for smooth and balanced door movement complete with installed hardware. Coordinate adjustment requirements with provisions of for detention door hardware and detention and electronic security controls.

END OF SECTION 111910

SECTION 11 19 20 - DETENTION HARDWARE

PART 1 - GENERAL

1.01. SECTION INCLUDES

- A. Detention hardware and related components.
 - 1. Provisions for detention steel doors and frames.

1.02 RELATED DOCUMENTS

- A. Drawing and general provisions of the Contract, including General and Supplementary Conditions, apply to this Section.

1.03 RELATED SECTIONS

- A. Division 11 Section 11 19 00, "Detention Equipment General Provisions."
- B. Division 11 Section 11 19 10, "Detention Hollow Metal Doors, and Frames."

1.04 REFERENCES

- A. American Correctional Association (ACA) – Standards for Correction Facilities.
- B. American Society of Mechanical Engineers (ASME).
- C. American Society of Testing and Materials (ASTM).
- D. ASTM F1577 Detention Locks for Swing Doors.
- E. ASTM F1643-95 Test Methods for Detention Sliding Door Locking Device Assembly.
- F. Builder's Hardware Manufacturer's Association (BHMA).
- G. Door and Hardware Institute (DHI).
- H. National Fire Protection Association (NFPA).
 - 1. NFPA 80 Fire Doors and Windows.
 - 2. NFPA 101 Life Safety Code.
- I. Underwriter's Laboratories, (UL) Inc.:
 - 1. UL 10B Fire Door Accessories.
 - 2. UL 1034 Burglary-Resistant Electric Locking.
 - 3. UL 437 Quality, Construction and Pick Resistance of Pin Cylinder.
 - 4. UL 643 Connectors and Switches for Low-Voltage Circuits.

- 5. UL 752 Bullet-Resisting Equipment
 - J. National Electrical Code, latest edition, for internal electrical requirements for hardware.
- 1.05 SUBMITTALS:
- A. Make submittals in accordance with the requirements of Division 1 Section "Submittals" and Division 11 Section 111900 "Detention Equipment General Requirements."
 - B. Submit specifications, installation instructions and general recommendations for products as required, including locks, hinges, lock mount covers, bolt keepers, wall bumpers, weatherstripping, thresholds, escutcheons, etc.
 - C. Hardware and Keying Schedules:
 - 1. General: Comply with requirements of Division 1.
 - 2. Product Data: Manufacturer's printed technical literature for products required by this Section.
 - 3. Security Hardware Schedule: Furnish in 8-1/2 inch x 11 inch or 11 inch x 17 inch format. Furnish a vertical listing of the hardware items used followed by manufacturer's name either on the cover sheet or immediately following the cover sheet; i.e. Hinges: (manufacturer's name). Schedule hardware items for each door separately in typed vertical form; list each door in numerical order under a separate heading using door number in door schedule. Security Hardware Schedule shall be kept current throughout the project. All hardware changes and/or revisions shall be submitted in the specified formant for insertion in the proper location in the approved "Security Hardware Schedule". A new title page shall accompany the new sheet(s) with a revision number and date.
 - 4. Catalog Cuts: Incorporate manufacturer's product catalog cuts for each type of hardware required within the Security Hardware Schedule into the Security Hardware Schedule.
 - 5. Templates for Fabrication:
 - a. Incorporate manufacturer's templates for each type of detention equipment hardware required within the Security Hardware Schedule into the Security Hardware Schedule.
 - D. Locking Device Shop Drawings:
 - 1. Incorporate locking device shop drawings into the Security Hardware Schedule.
 - 2. Indicate layout plans of each opening at 1/2" = 1'-0" minimum scale, show anchorage and accessory items, dimensions and finishes.
 - E. Samples: When requested by the Architect or Owner, provide full size sample of each lock, locking device, and miscellaneous security hardware. Include two samples for each hinge and latchset illustrating style and finish.

- F. Closeout Submittals - Furnish three copies of Operating/Maintenance Manuals including parts lists for security locks and locking devices.

1.06 SHOP DRAWING REVIEW SESSION: OMMITED

1.07 QUALITY ASSURANCE

- A. Throughout the specifications and drawings, types of materials may be specified by the manufacturer's name and catalog number in order to establish standards of quality and performance. If the bidder elects to substitute any other products, s/he must request the Architect's approval in writing no later than twenty-one (21) days prior to the bid date and s/he must receive written approval by addendum. The following are requirements for approval for each type of product listed.

1. For each facility, list: name and location of installation, value of contract, scope of work provided, date of occupancy by Owner, Owner's representative to contact and telephone number, Construction Manager or General Contractor, and Architect. Indicate length of delivery after receipt of approved submittals.
2. Manufacturers Qualifications: Provide security equipment products from manufacturers that have been actively engaged in the production of security equipment for a minimum of ten (10) years in successfully completing projects of equal scope and magnitude with products as herein specified. This evidence shall consist of a list of ten (10) projects that have been complete and operational for a minimum of five (5). The manufacturer shall now be actively engaged in the design and manufacture of security locks, locking devices, furnishings and miscellaneous security hardware and products. All locks, locking devices and related security hardware shall be manufactured and supplied by the same manufacturer.
3. Five (5) copies of manufacturer's product specifications and catalog cut sheets and detail and performance data for each type product listed in this section.
4. Provide data substantiating that products being proposed for this project comply with the requirements stated herein. Provide detailed explanation of the differences of proposed products and the specified products.
5. List of projects under construction
6. List of completed projects
7. List of major suppliers

- B. Approved Detention Hardware Suppliers:

1. Southern Steel, San Antonio, TX
2. Folger Adam, San Antonio
3. AirTeq Locking Systems, Montgomery, AL
4. R.R. Brink Locking Systems, Shorewood, IL

- C. DEC Sole Responsibility:

1. General: Comply with pre-qualification requirements of Section 111900.
 2. Provide complete, operational, and functional security system, including door hardware, its electronic components, conduit, and wiring from power supply panel boards, and requirements for products and materials specified in other related Sections.
- D. DEC Firms: Acceptable and pre-qualified firms are listed in Section 111900.
- E. Single Source: Provide locks, locking devices, and associated security hardware of same type and function produced by single manufacturer.
- F. Compatibility with existing conditions - equipments, software and program, keying and locking systems, etc.: The existing system and the new system shall be compatible – refer to manufacturer specifications of existing systems. Contractor shall address the keying and key sections provided under this specification to match existing systems and or be an augmentation of the same. All new keying must be assure that it is free of unwanted interchange, and will not cause interchange in existing keying. Modification of another manufacturer's key section to match existing must be indicated in your proposal and approved by DGS.

1.08 PRODUCT HANDLING

- A. Comply with requirements of Division 11 Section 111900 "Detention Equipment General Requirements".
- B. For products delivered to door manufacturer and for products delivered to project site, package each item of hardware separately in containers, complete with necessary fasteners, installation instructions, and installation templates. Mark each container with item numbers, location of installation in accord with corresponding information shown on final hardware schedule.
- C. Store products at site to prevent damage or loss until installation is made.
- D. Control handling and installation of hardware products which are not immediately replaceable, so that the completion of work will not be delayed by hardware losses, both before and after installation.
- E. Deliver all keys in one shipment by secure carrier (hand carrier or registered mail) from manufacturer directly to authorized representative of the Owner, as directed by the Architect-Engineer. Include transmittal and forward copy of same to the Architect-Engineer.

1.08 WARRANTY

- A. Comply with requirements of Division 1.

- B. Provide a five-year warranty; 1. door closers, 2. locking devices, deadlocks and deadlatches, and other miscellaneous locksets included in this Section.

1.09 MAINTENANCE

- A. Provide spares in the quantities listed below for each hardware type:
 - 1. Escutcheon: One of each type used.
 - 2. Cylinder Shield: One of each type used.
 - 3. Hinges - A: Two of each type used.
 - 4. Pulls:
 - a. Door Pull: Two of each type used
 - b. Flush Pull: Two of each type used
- B. Fasteners and Accessories:
 - 1. Furnish two percent extra fasteners and other miscellaneous accessories required for installation.
- C. Furnish, for institution use only, one complete set of:
 - 1. Special tools required for locking device and hardware maintenance
 - 2. Lock repair kits

PART 2 - PRODUCTS

2.01. MANUFACTURER

- A. Catalog numbers of the first manufacturers listed have been used to establish the quality required. The only other manufacturers approved are listed. Other manufacturers seeking approval shall do so in writing per General Requirements and shall list exact catalog numbers and description of the items proposed to furnish.

ITEM	1	2
Hinges	Southern Steel	Folger Adam
Closers	LCN	Norton
Stops	H.B. Ives	Glynn-Johnson
Holders, Surface Bolts	Glynn-Johnson	Checkmate
Push, Pull	Hiawatha	Brookline
Thresholds	Pemko	Reese
Weatherstrip	Pemko	Reese
Security Hardware	Southern Steel	Folger Adam

- B. DESIGNATIONS: Following abbreviations identify listed manufacturers:

Brookline	Brookline Industries, Chicago, IL
Checkmate	Rixon, Inc.; Franklin Park, IL

Glynn-Johnson	Glynn-Johnson Corp.; Chicago, IL
Hiawatha	Metalcraft, Inc.; Minneapolis, MN
Ives	H. B. Ives Div.; New Haven, CT
LCN	LCN Closers; Princeton, IL
Norton	Norton Closer Div.; Charlotte, NC
Pemko	Pemko Mfg. Co.; Emeryville, CA
Reese	Reese Enterprises; Rosemount, MN
Southern Steel	San Antonio, TX
Folger Adam	San Antonio, TX
AirTeq	Montgomery, AL
Brink	Shorewood, IL

2.02. SCREWS, FASTENERS AND TOOLS

- A. Furnish exposed fasteners to match item fastened. Make fastener of the same metal as item fastened, except use plated brass or stainless steel for all aluminum items. Provide five (5) spares of each type of fastener used for anchoring hardware.
- B. Provide torx-head (star design with center pin) security fasteners for exposed fasteners on all security hardware, regardless of manufacturer. Furnish two (2) tool holders and two (2) bits for each different size screw. Holders and bits shall be left at project after installation and become property of the user.

2.03. ELECTRIC SECURITY DEVICES FOR SLIDING DOORS - OMMITED

2.04. MECHANICAL SECURITY HARDWARE FOR SLIDING DOORS - OMMITED

2.05 MECHANICAL SECURITY HARDWARE

- A. General: Comply with the requirements of ASTM F 1577 for tests involving detention locks for swing doors.
- B. Institutional Hinge:
 - 1. 204FMSS/Southern Steel
 - a. Description:
 - 1) 4-1/2 x 4-1/2, 3/16" thick leaves maximum
 - 2) Stainless steel leaves, stainless steel non-removable pin, two hardened steel ball bearings, three knuckle with HT hospital tips.
 - 3) 1/2" diameter pin to lock hinge in closed position
 - b. Provide quantities as follows:
 - 1) Doors less than 5 ft high - 1 pair
 - 2) Doors over 5 ft to 7 ft 6 in high - 1-1/2 pair

- 3) Doors over 7 ft 6 in to 10 ft high - 2 pair
- 4) Doors over 3 ft 8 in wide - 2 pair

2.06 DOOR POSITION SWITCH

A. Series/Manufacturer:

1. 220A/Southern Steel
2. Description:
 - a. 6-1/4" x 2-1/2" x 1-7/8"
 - b. Enclosed is a 10 gauge galvanized steel housing
 - c. Surface mounted to frame with a pivoting operator that actuates internal switch mounted to the door face.

2.07 PULLS

A. Raised Door Pull

1. Series/Manufacturer: 212B/Southern Steel
 - a. Description: Cast brass, US4, 8-11/16" L x 1-3/4" W x 2-3/8" projection. Fasteners shall be 2-3/8" - 16 x 3/4" security screws
2. Series/Manufacturer: 212C/Southern Steel
 - a. Description: Cast brass, US26D, 8-11/16" L x 1-3/4" W x 2-3/8" projection. Fasteners shall be 2-3/8" - 16 x 3/4" security screws.

B. Recessed Door Pull

1. Series/Manufacturer: 214S/Southern Steel
 - a. Description: Cast brass, US26D, 5" high x 4" wide x 1" deep. Fasteners shall be 1/4" - 20 x 5/16" security screws.
2. Series/Manufacturer: 214B/Southern Steel
 - a. Description: Cast brass, US4, 5" H x 4" W x 1" D. Fasteners shall be 1/4" - 20 x 5/16" security screws.

C. Flush Door Pull: By door manufacturer.

2.08 STOPS

A. Door stop: AT 650

1. Material: 5/8" x 2-12" steel shank.
2. Bumper: 2" diameter black silicone rubber.

2.09 ELECTRICAL COMPONENTS

- A. Devices: Factory wired to multi pin connector located within housing above each door.
1. Switches: U.L. recognized for use in function of device and for door status indications.
 2. Limit Switches: Rated 5 to 15 amps.
 3. Solenoids: Rated by their manufacturer for continuous operation.
 4. Supply electrically controlled devices with status switches to allow for status indication and interlocking capabilities.
- B. Magnetic Recessed Door Position Switch: AT DPS6200, or Sentrol #2767:
1. Type: Magnet mortised type assembly used for remotely monitoring door status/position, moisture resistant, and fit within 2 inches wide hollow metal door jamb. Provide device with field adjustable on 2 axis' and supplied with a 3 feet of vinyl jacketed lead wire and a 3 pin Molex connector.
 2. Fabrication: Steel construction with switch and magnet encased in epoxy resin.
 3. Overall Size: 1-1/4 inches by 4-7/8 inches by 1 inch.
- C. High Security Closer/Door Position Switches: LCN #2210 AVE DPS AL.
1. Overhead Concealed Closers: Extra heavy duty with forged steel concealed arm tested to ten million (10,000,000) opening-closing cycles with full hydraulic rack and pinion action and high strength cast iron cylinder.
 2. Spring Power: Adjustable from size III through size V.
 3. Hydraulic Fluid: Type requiring no seasonal adjustment for temperatures ranging from 120 degrees F to minus 30 degrees F.
 4. Control: Provide separate tamper-proof screw valves for independent regularization of latch speed, general speed, and hydraulic back check.
 5. Regulating Screws: Accessible through a heavy duty mounting plate when finish plates are removed.
 6. Electronic Rating: Integral electro-mechanical device rated not less than 24 VAC at 10 amperes to detect and signal rotation of closer pinion, and field adjustable to allow setting for each door and fitting with a protective shield.
 7. Finish Plate: Fully conceal all adjustment mechanisms.
 8. Low Friction Track Roller: Attached to arm by threaded mounting.
 9. Metal Track: Design to prevent jaming and will eject foreign objects placed in track mortised into top of door.
 10. Exposed Fasteners: Security type. See Section 111960.
- D. Key Switches: ASSA V-10 key switch for flush mounting.

1. Stamp for pin tumbler locks from CDA-78200 hard-temper alloy, with a hardness of 85 on the Rockwell B scale.
2. Cylinders: Two-inch diameter brass with stainless steel balls, tumblers, and springs. Using a combination of pin, side, and top tumblers, key cylinder in three security levels to segregated areas within the building. Provide manufacturer's written certification that keying is free from unwanted interchange and is not assigned to other institutions in close proximity. Comply with UL437, and label by a nationally recognized independent testing laboratory.
3. Switch: UL listed, 15 Amp rated form C contact.
4. Indicator Lights: LED, red and green.
5. Red LED indicates "unlocked" or "on"; green LED indicates "locked" or "off" as indicated.
6. Tamper Resistant: Case and cover assembly.
7. Electric Contact: Furnish a form C contact to control electric locks or lighting as indicated, two form C contacts for electric operated doors.
8. Exposed Screws: Comply with requirements of Section 111960 for security fasteners.

2.10 FINISHES

	<u>U/S Symbol</u>	<u>ANSI Symbol</u>	<u>Description</u>
Hinges, Exterior	US32D	630	Satin Stainless Steel
Hinges, Interior	US26D	626	Satin Chrome
Locks & Pulls	US26D	626	Satin Chrome
Closers	AL	689	Aluminum Painted
Push, Kick	US32D	630	Satin Stainless Steel
Stops	US26D	626	Satin Chrome

2.11 CYLINDERS, KEYS AND KEYING

- A. The security locks will incorporate three (3) separate keying systems; one for pin tumbler (mogul cylinder) and one for commercial cylinder locks. Each keying system's keys shall be dye stamped for identification; corresponding to the hardware supplier's final schematic keying chart (See Paragraph 'D').
- B. Mogul cylinder locks shall be master keyed as directed. Provide cut change keys, and master keys as required.
- C. For all individual key designations, to each required individual Key Cabinet, there shall be two (2) keys provided. For each master key designation, there shall be three (3) keys for each required individual key cabinet.
- D. A complete, detailed schematic chart of the keying system will be required. The hardware supplier will also be required to enter the key symbols for all doors on additional floor plans which will be supplied by the Architect. Two (2) copies of the schematic keying chart and architectural floor plans shall be turned over to the user at the completion of the project. The cost for this service shall be included with the cost of materials at the time of bidding.

2.12 KEY CABINET - OMMITED

2.13 SECURITY SPARE LOCKS AND LOCK PARTS

- A. Shall be provided for the Owners' stock as follows:
 - 1. One complete set of security screw drivers for all sizes of security screws used on this project.
 - 2. One repair parts list and assembly drawings bound in a manual for all security products supplied in this section.

2.14 DOOR AND HARDWARE SCHEDULE

- A. The hardware group/sets listed below indicate the items of hardware required for each opening. It is the bidder's responsibility to accurately furnish the proper sizes, quantities, weights, gage, and function as required by these specifications and as recommended by manufacturers involved.

PART 3 - EXECUTION

3.01. GENERAL

- A. Comply with requirements of Division 11 Section "Detention Equipment General Requirements."

3.02. INSTALLATION

- A. Comply with requirements of Division 11 Section "Detention Equipment General Requirements."
- B. All shipping of detention equipment hardware and coordination with other detention equipment shall be the responsibility of the Detention Equipment Supplier.

3.03. FIELD QUALITY CONTROL

- A. Comply with requirements of Division 11 Section "Detention Equipment General Requirements."

3.04. ADJUSTMENT AND REPAIRING

- A. Comply with requirements of Division 11 Section "Detention Equipment General Requirements."

3.05. PROTECTION AND CLEANING

- A. Comply with requirements of Division 11 Section "Detention Equipment General Requirements."

3.06. SECURITY HARDWARE SETS

SH-4 Dead Lock – Wire Mesh Door

Quantity	Description	Manufacturer
1	1080A-2 Lock x Galv.	Southern Folger
3	204FMSS Hinge x US32D	Southern Folger
1	1080HM Mounting Plate x USP	Southern Folger
2	212C Raised Door Pull x US32D (Hinge Side)	Southern Folger
3	GJ-64 Door Silencer	Glynn-Johnson
1	Stop (467 - Floor Stop)	Rockwood

SH-4A Storeroom Fire – Double Door

Quantity	Description	Manufacturer
1	1070A-1 Combination Spring and Deadlock x Galv.	Southern Folger
8	204FMSS Hinge x US32D	Southern Folger
1	1070HM Mounting Plate x USP	Southern Folger
1	212C Raised Door Pull x US32D (Hinge Side)	Southern Folger
1	214S Recessed Door Pull (Stop Side)	Southern Folger
2	10105 Head/Foot Bolt x/1–10105R Receptacle x Galv.	Southern Folger
2	2210DPS Closer x AL	LCN
1	S88BL Gasket x 24'-0"	Pemko

SH-4B Storeroom Fire – Double Door

Quantity	Description	Manufacturer
1	1070A-2 Combination Spring and Deadlock x Galv.	Southern Folger
8	204FMSS Hinge x US32D	Southern Folger
1	1070HM Mounting Plate x USP	Southern Folger
1	214S Recessed Door Pull x US32D (Hinge Side)	Southern Folger
1	214S Recessed Door Pull x US32D (Stop Side)	Southern Folger
2	10105 Head/Foot Bolt x/1–10105R Receptacle x Galv.	Southern Folger
2	2210DPS Closer x AL	LCN
1	S88BL Gasket x 24'-0"	Pemko

END OF SECTION 11 19 20

SECTION 111950 – SECURITY BAR GRATINGS

PART 1 - GENERAL

1.1 DESCRIPTION

- A. Grating panels shown on plans and described in these specifications meet or exceed industry standards for this type of product. Other manufacturers seeking approval must have at least five years of current experience in manufacturing similar products.
- B. Provide bar grates and grilles for openings at or greater than 6-inches by 6-inches, that penetrate the roof in secure areas, security walls, floors, and ceilings, including HVAC openings, unless otherwise indicated.
- C. Security round and flat bars as well as perimeter angle and/or plate frame and sub-frame members shall be fabricated from 1018 alloy steel and made tool-resistant in compliance with ASTM A627. Submit independent laboratory certification of ASTM compliance with submittal.

1.2 SUBMITTALS

- A. The manufacturer is to submit shop drawings showing the construction of material to be supplied, attachment to surrounding materials, and elevations showing scope of project.

1.3 WARRANTY

- A. The material supplier shall warrant the material and workmanship on this project for one year from date of acceptance by Owner. The manufacturer agrees to repair or replace any defective materials and to correct any defects when given written notice by the Owner during this warranty period. The warranty does not cover abuse by others or wear from normal use.

PART 2 - PRODUCTS

2.1 SECURITY BAR-GRILLE ASSEMBLIES

- A. **Manufacturers:** Subject to compliance with requirements, provide products by one of the following:
 - 1. [American Jail Products L.L.C.](#)
 - 2. [C.M. Security Group Inc.](#)
 - 3. [DDS Group.](#)
 - 4. [Kenco Wire & Iron Products Inc.](#)

5. [Maximum Security Products Corp.](#)
6. [Peterson Detention Inc. \(PDI\).](#)
7. [PSI LLC.](#)
8. [Sweeper Metal Fabricators Corp.](#)

B. Tool-Resisting-Steel Bar Grilles: ASTM A 627, Grade 2.

1. Vertical Bars: 1-inch- diameter, double-ribbed, round or hexagonal composite tool-resisting-steel bars at 6 inches o.c.
2. Horizontal Flat Bars: 3/8-by-2-1/2-inch composite tool-resisting-steel flat bars at 12 inches o.c.
3. Perimeter Framing: 3/8-by-2-1/2-inch composite tool-resisting-steel flat bars.

C. Materials:

1. Tool-Resisting-Steel Round and Flat Bars: ASTM A 627.
2. Mild-Steel Plates, Shapes, and Bars: ASTM A 36/A 36M.

D. Finishes:

1. Steel Prime Finish: Clean, pretreat, and apply manufacturer's standard primer.

2.2 FINISH

- A. Interior Applications Factory Primer (Standard) - After Fabrication, clean all surfaces of grating panels using iron phosphate or comparable cleaner / degreaser. After material has completely dried from cleaning process, apply one coat of standard shop primer.
- B. Exterior Applications - Grating panels shall be galvanized after fabrication.
- C. Powder Coat (Option) - After Fabrication, clean all surfaces of grating panels using iron phosphate or comparable cleaner/degreaser. After material has completely dried from cleaning process, apply powder coat finish (color selected by architect). Powder coat to be applied per powder manufacturer requirements using electro-static application equipment.

2.3 MOUNTING ACCESSORIES

- A. Manufacturer will supply all mounting angles, cover plates or channels for installation of grating panels into clear opening.
- B. Supply mounting accessories with finish as required for each location.

2.4 FABRICATION OF BAR-GRILLE ASSEMBLIES

- A. Fabricate bar-grille assemblies with materials and to sizes and configurations indicated, complete with mounting flanges and anchors.

1. Pass vertical round bars through, and positively interlock them with, horizontal flat bars at each intersection without reducing circumference of round bars at these intersections and without using pipe sleeves, swedging, calking, or interlocks that depend on friction. Weld vertical round bars at each intersection with flat bars.
 2. Pass ends of round bars at least 1 inch through framing, and weld bars to framing from back side of framing.
 3. Fabricate cutouts and openings in bar-grille assemblies for penetrations of sizes and at locations indicated. Frame openings with flat bars of same material and size as horizontal flat bars.
 4. Frame connections with plates; use flat bars of same material and size as horizontal flat bars.
- B. Partitions: Connect top horizontal flat bar to vertical flat bar framing members with 2-by-2-by-1/4-inch-thick, steel plate angle knee welded into place. Connect intersections of horizontal flat bars with vertical flat bar framing members by 3/16-inch fillet welds. Weld vertical bars securely to top and bottom flat bar framing members.

PART 3 - EXECUTION

3.1 FIELD VERIFICATION

- A. Verify in field that all openings that are to receive grating panels are per approved shop drawings, are level, and clean.

3.2 INSTALLATION

- A. Install per approved shop drawings and specifications.
- B. Plumb and align mounting angles on a single plane with anchors per approved shop drawing.
- C. Plug weld and/or stitch weld security grating bar assembly to full perimeter angle or plate frame and sub-frame at 10-inches on center with 1/2-inch diameter plug welds and/or 1-1/2-inch long stitch welds at 10-inches on center staggered.

3.3 FIELD QUALITY CONTROL

- A. Prepare inspection reports and indicate compliance with and deviations from the Contract Documents.
- B. Remove and replace detention work if inspections indicate that work does not comply with specified requirements. Remove malfunctioning units; replace with new units.
- C. Perform additional inspections to determine compliance of replaced or additional work. Prepare inspection reports.

3.4 CLEANING AND PROTECTION

- A. Touchup Painting: Immediately after erection, clean bolted connections and abraded areas of shop paint, and paint exposed areas with same material used for shop painting to comply with SSPC-PA 1 for touching up shop-painted surfaces.
- B. Galvanized Surfaces: Clean field welds, bolted connections, and abraded areas; repair galvanizing to comply with ASTM A 780.

END OF SECTION 111950

SECTION 111960 - SECURITY FASTENERS

PART 1 - GENERAL

1.1 RELATED DOCUMENTS

- A. Drawings and general provisions of the Contract, including General and Supplementary Conditions and Division 1 Specification Sections, apply to this Section.

1.2 SUMMARY

- A. This Section includes security fasteners.

1.3 PERFORMANCE REQUIREMENTS

- A. Capable of withstanding numerous removals and replacements with security fastener tools and operable by a maximum of 2 different types of tools.

1.4 SUBMITTALS

- A. Product Data: For each type of product indicated.

1.5 EXTRA MATERIALS

- A. Furnish Owner with 6 separate tool kits, each kit containing 1 of each type of tool required for fastening or unfastening each type of security fastener required.

PART 2 - PRODUCTS

2.1 MANUFACTURERS

- A. Security Screws:
 - 1. Available Manufacturers: Subject to compliance with requirements, manufacturers offering products that may be incorporated into the Work include, but are not limited to, the following:
 - a. Camcar Division of Textron, Inc., Rockford, Illinois, 815/226/7721.
 - b. Holo-Krome Company, West Hartford, Connecticut, 203/523/5235.
 - c. Rielock Company, Freeport, New York, 516/378/1020.
 - d. Safety Socket Screw Corporation, Chicago, Illinois, 312/763/2020.
 - e. Tamper-Pruf Screws, Inc., Paramount, California, 213/531/9364.
 - f. Accepted substitute in accordance with Section 016000.

B. Security Fasteners Bolts and Nuts

1. In other Part 2 articles where subparagraph titles below introduce lists, the following requirements apply for product selections:
 - a. Available Products: Subject to compliance with requirements, products that may be incorporated into the Work include, but are not limited to, the products specified.

2.2 SECURITY SCREWS

- A. Provide material head style and plating appropriate for installation requirements, and strength and finish of adjacent materials. Provide stainless steel for screws in painted material.
1. Types Allowed: Pinned Allen head and pinned Torx head.
 2. Diameters: No. 4 through 3/4 inch.
 3. Threads: 28 to 32 threads per inch.
 4. Material: Black Grade 9 alloy steel, Austenitic stainless steel, or Martensitic stainless steel, as required for particular strength and finish.
 5. Head Styles: Socket head cap, button, flat, or low head, as required by application or as specified. Provide Allen head type for screw sizes No. 6, No. 8, and No. 10.
 6. Plating: Cadmium, zinc, nickel, phosphate, or chrome to match adjacent materials.

2.3 SECURITY FASTENERS BOLTS AND NUTS

- A. General: Provide security type fasteners throughout the facility inclusive of factory fabricated products, assemblies, and for installations such as door hardware, hinges, equipment and other items accessible to inmates, unless specifically excluded.
1. Fabricated Products: Where fasteners are exposed, replace manufacturer's standard fasteners with specified security type fasteners of same finish as replaced fastener.
 2. Sizes: Provide fastener lengths and sizes for attaching furnishings and equipment to substrate to meet live and dead load requirements.
 3. Embed Inserts: Coordinate selected type with fastener, material substrate, and loading requirements.
- B. Type-1:
1. High security/detention, zinc-nickel coated fasteners with computer generated head design for use with manufacturer's registered tool for removal. Provide at the following locations and installation:
 - a. Within Inmate Cells: At mirrors, light fixtures, device plate covers, flush door pull, and other similar detention furnishings and equipment, except bunks, writing surfaces, stools, and shelf units.
 2. Acceptable Product: McGard "Intimidator" security fastener by McGard Special Products Division, 3875 California Road, Orchard Park, New York 14127.

- C. Type-2:
1. Tamper-proof bolt and nut; ASTM A 307 strength, solid bar steel, standard course tread, non-corrosive zinc-nickel coated or Type 316 stainless steel with break-off "button" style head at bolts and break-off hex head nuts leaving a "round" nut body that cannot be removed unless the bolts are drilled and extracted and the nuts are cut off. Provide at the following locations and installations:
 - a. At bunks, clothes hooks, shelf units, stools, wall shelf, wall bench, TV monitor stands, writing surfaces, privacy screen panels, woven rod panels, and all other floor or wall mounted items that are exposed to view in the defined security/detention areas.
 2. Acceptable Manufacturers:
 - a. J.P. Ruklic, 17200 Palmer road, Homewood, IL.
 - b. B&G Manufacturing, 3067 Unionville Pike, Hatfield, PA.
 - c. Guardnut, Inc., Santa Rosa, CA.
- D. Type-3:
1. Tamper-resistant center pin reject style, minimum 1-1/2-inch-long fasteners that may be removed only with manufacturer's specially designed extraction tool. Provide at the following locations and installations:
 - a. Building exterior.
 - b. Within exterior Security Perimeter, including inmate areas, and correctional officer areas, (inclusive of stairwells), mechanical, elevator equipment, and electrical rooms, but excluding interior of inmate cells.
 2. Acceptable Product: "Torx Style 2" security fasteners by Camcar Division of Textron, Inc.
- E. Type-4:
1. Provide non-corrosive zinc-nickel coated steel or Type 316 stainless steel fasteners, nuts and washers, and slot, "Phillips," or hex head fasteners or bolts for the intended function. Provide at the following locations and installations:
 - a. Areas and spaces not within identified security/detention spaces, inclusive of its perimeter.
 2. Acceptable Products: Distributed through McMaster-Carr Supply Co., or equal.

PART 3 - EXECUTION

3.1 PREPARATION

- A. Manufacturers, Suppliers, and Installers of Components Requiring Use of Security Fasteners: Obtain proper size and type security fasteners for each required application.

3.2 INSTALLATION

- A. Manufacturer, Suppliers, and Installers of Components Requiring Use of Security Fasteners: Install security fasteners as recommended by manufacturer.

END OF SECTION 111960

SECTION 111990 - SECURITY HOLLOW METAL PANEL WALL SYSTEM

PART 1 -GENERAL

1.1 SECTION INCLUDES

- A. Furnish and install security hollow metal panel wall system (Laundry Room, etc.), comprising two inch thick wall panels filled with fire retardant foam. Fire rated panels are to be grout filled. The scope of work covered by this section includes furnishing, erecting the wall panel system, in its entirety. The wall panel system shall not be employed to carry any structural loads of the surrounding building, equipment (except for equipment shown connected to the walls such as benches, toilet fixtures, countertops, etc.), or other items unless specified herein or shown in the drawings.

1.2 PRODUCTS FURNISHED AND INSTALLED UNDER THIS SECTION

- A. Prior to initiation of the work under this section, contractor will verify that the project is prepared to receive the wall panel system. The structure is prepared to receive the wall panel system, and contractor will have access to the location for the erection of the wall panel system, in coordination and conjunction with other trades during wall panel system construction and installation. Additionally, the concrete slab or floor surface is in conformity with thickness, leveling and reinforcing required for structural requirements of the project and wall panel system.
 - 1. Insulated Metal Panels comprising two inch thick double skinned steel panels as indicated.
 - 2. Security hollow metal doors, and frames shall be shop welded into the wall panel system at the manufacturer's facility and fully foam filled.
 - 3. All floor and ceiling channels and miscellaneous cell panel connection materials as required for a complete and functional system.
 - 4. Foam filling of all wall panels.

1.3 RELATED DOCUMENTS

- A. Drawings and provisions of Contract, including General and Supplementary Conditions and Division 1 specification Sections, apply to Work in this Section.
- B. Related Sections:
 - 1. Division 1 – General Requirements for coordination with all other aspects of the project work.
 - 2. 07 9200 - Joint Sealants for sealing of all joints and gaps in wall system
 - 3. Section 111900 - Detention Equipment General Requirements for DEC coordination requirements
 - 4. Section 111960 - Security Fasteners for all connections of walls with and to other systems.

1.4 REFERENCES

- A. ASTM A1008/A1008M – Specification for Steel, Sheet, Cold-Rolled, Carbon, Structural High Strength Low-Allow, High Strength Low-Alloy with Improved Formability, Solution Hardened, and Bake Hardenable
- B. ASTM A1011/A1011M – Specification for Steel, Sheet, and Strip, Hot-Rolled, Carbon, Structural, High Strength Low-Allow and High Strength Low-Alloy with Improved Formability
- C. ASTM A653/A653M - Specification for Steel Sheet, Zinc-Coated (Galvanized) or Zinc-Iron Alloy-Coated (Galvannealed) by the Hot-Dip Process(Commercial Steel)
- D. ASTM A666 - Specification for Austenitic Stainless Steel Sheet, Strip, Plate and Flat Bar
- E. ASTM A627– Standard Test Methods for Tool-Resisting Steel Bars, Flats, and Shapes for Detention and Correctional Facilities
- F. ASTM C 143 / C 143M, Standard Test Method for Slump of Hydraulic Cement Concrete.
- G. ASTM-E119, Standard Methods of Fire Tests of Building Construction and Materials.
- H. NFPA-251, Fire Tests of Building Construction and Materials
- I. UBC-7-1, Uniform Building Code Standard
- J. UL-263, Fire Tests of Building Construction and Materials
- K. CAN/ULC-S101, Standard Methods of Fire Endurance Tests of Building Construction and Materials.
- L. ANSI A 250.10, Standard Test Procedure and Acceptance Criteria for Prime Painted Steel Surfaces for Steel Doors and Frames
- M. ASTM F 1450-12a, Standard Test Methods for Hollow Metal Swinging Door Assemblies for Detention and Correctional Facilities
- N. ASTM F 1592, Standard Test Methods for Detention Hollow Metal Vision Systems
- O. ASTM F 2322, Standard test Methods for Physical Assault on Vertical Fixed Barriers for Detention and Correctional Facilities.
- P. NAAMM HMMA 840, Installation and Storage of Hollow Metal Doors and Frames

- Q. ANSI / NAAMM HMMA 866, Guide Specifications for Stainless Steel Hollow Metal Doors and Frames
- R. ANSI / NFPA 80, Fire Doors and Windows
- S. ANSI / NFPA 252, Standard Methods of Fire Tests of Door Assemblies
- T. ANSI / NFPA 257, Methods for Fire Test of Window Assemblies
- U. ANSI / UL 9, Fire Test of Window Assemblies, 7th Edition
- V. ANSI / UL 10B, Fire Test of Door Assemblies, 9th Edition
- W. ANSI / UL 10C, Standard for Positive Pressure Fire Tests of Door Assemblies
- X. ICBO UBC 7-2, Fire Tests of Door Assemblies
- Y. ICBO UBC 7-4, Fire Tests of Window Assemblies
- Z. UL 752, Bullet Resisting Equipment

1.5 TESTING AND PERFORMANCE

- A. Security Metal Wall Panel Manufacturers interested in providing products for this project shall submit the following data with their Substitution Request, in addition to their qualifications as per Article "Quality Assurance". Failure to include all required information below; will be grounds for rejection of the request.
- B. Performance test requirements for each wall panel type and opening shall be as indicated for individual grade number designations shown in the tables in ASTM F 2322, ASTM F 1450 and ASTM F 1592. Test procedures shall be performed on wall designs as described in Sections A, B, C, D, E, F, G and H. Panels shall perform to the requirements set for in this specification section as well as indicated on the drawings.
- C. Wall Assembly Impact Test performed in accordance with ASTM F 2322
 1. Scope and Significance: This test method is a simulated service test for determining the performance characteristics of walls designed to incarcerate inmates in detention and correctional institutions. The testing provides for the setup and impact testing of a sample wall.
 2. Test Sample: A wall consisting of two 8'-0" x 8'-0" (914 mm x 2438 mm) wall sections shall be constructed in accordance with section 2.02.
 3. Test Requirements: Subject one location on the sample wall to 600 blows equally divided between a sharp and a blunt impactor. The blunt impactor shall deliver the required impacts at 200-foot pounds per impact while the sharp impactor shall deliver the required impacts at 100-foot pounds per impact to the sample location. Repeatability of impact location during each series shall be no more than +/-2 inches horizontally and vertically from the designated impact target. Testing shall take no longer than 60

minutes. Specimen fails if a 5" x 5" x 8" rectangular box can pass through the wall following impacts.

D. Wall De-lamination Test

1. Scope and Significance: This test documents the overall integrity of the panel system, resistance to possible delamination, and prevention of bulging of panels during grout application.
2. Test Sample: A 4' X 4' (101.6 mm X 101.6 mm) sample shall be constructed in accordance with specification. No end closing pieces are to be used in this test. Test sample without grout or insulation.
3. Apparatus: Using a steel I-beam table capable of withstanding a load of 10,000 pounds with no deflection, fix to the tabletop a steel I-beam enclosure to accommodate the sample.
4. Procedure:
 - a. Mount the sample in the test fixture and weld the bottom face sheet at its center to the I-beam tabletop.
 - b. Weld a 3" x 3" (76.2 mm X 76.2 mm) .250" (6.4 mm) thick steel plate centered on the top face sheet. Center on the 3" x 3" (76.2 mm X 76.2 mm) .250" (6.4 mm) thick steel plate an eyelet.
 - c. Using a hydraulic porta-power and a calibrated load cell to measure pounds force, pull on the eyelet in an upward direction.
 - d. Use a dial indicator to measure the deflection at the center of the sample.
5. Pass/Fail Criteria: Apply 3000 pound load and measure the deflection. The maximum deflection allowable is .125" (3.2 mm). A "Pass" result in accordance with this pass/fail criteria is required in order to qualify as a provider of the wall panel system specified herein.

E. Bullet Resistance Test

1. Bullet resistance shall be certified by the application of the laboratory bullet resistance rating label on the door for the opening indicating compliance with the testing procedure described in UL Standard 752. The bullet resistance rating shall be Level 3.

F. Detention Furnishing and Equipment Static Load Test

1. Scope: This test simulates a wall panel's resistance to bending when loads are applied to cell furnishings.
2. Significance of Use: The primary purpose of this test is to approximate the levels of pressure apparent when an inmate jumps on the outer edge of a bunk, desk or stool.
3. Test Sample: Erect a wall or use the same wall as specified under the Wall Impact Test consisting of three 3'-0" x 8'-0" (914 mm x 2438 mm) panels constructed in accordance with specification.
4. Apparatus: Attach the piece of furniture by typical means (bolting or welding) to the wall panel system.

5. Procedure: Apply a load to the outer edge of the furniture item using a hydraulic porta-power and a load cell to measure pounds force. Apply 1,500 pounds.
6. Pass/Fail Criteria: No permanent visible disfigurement is allowed to the wall panel system. A "Pass" result in accordance with this pass/fail criteria is required in order to qualify as a provider of the wall panel system specified herein.

G. Acoustical Tests

1. Erect a wall or use the same wall as specified under the Wall Impact Test consisting of three 3'-0" x 8'-0" (914 mm x 2438 mm) panels constructed in accordance with specification. Sample shall be tested with factory-installed insulation.
 - a. Conduct these tests on grouted samples in accordance with: ASTM E90 Standard Test Classification for Determination of Sound Transmission Class. (Minimum STC class rating of 44-45), and ASTM E1332 Standard Test Classification for Determination of Outdoor-Indoor Transmission Class. (Minimum OITC class rating is 41)
 - b. Conduct these tests on factory insulated samples in accordance with: ASTM E90, "Standard Test Classification for Determination of Sound Transmission Class", Minimum Sound Transmission Class (STC) rating of 39, and ASTM E1332, "Standard Test Classification for Determination of Outdoor-Indoor Transmission Class (OITC)", Minimum OITC class rating is 36.

H. Fire Rated Wall Assemblies

1. Where indicated and required by code, supply fire rated temperature rise walls with ratings of one hour or two hour rating as determined and scheduled by the documents. Such products shall be tested in accordance with ASTM-E119, Standard Methods of Fire Tests of Building Construction and Materials; CAN/ULC-S101, Standard Methods of Fire Endurance Tests of Building Construction and Materials; NFPA-251, Fire Tests of Building Construction and Materials; UBC-7-1, Uniform Building Code Standard; UL-263, Fire Tests of Building Construction and Materials; and shall be constructed as listed and/or classified by a recognized testing agency having a factory inspection service.

I. Test Reports

1. The manufacturer shall provide test reports and documentation by an independent testing laboratory documenting successful completion of each performance test. Where ASTM and ANSI standard test methods are specified, reporting shall be in accordance with the applicable standard, all test reports shall be current within the most current revision of the standard and performed under the manufacturer's current organizational structure.

1.6 QUALITY ASSURANCE

- A. Professional Engineer Qualifications: A professional engineer who is legally authorized to practice in the jurisdiction where project is located and who is experienced in providing engineering services of the kind indicated. Engineering services are defined as those performed for installation of steel detention wall panel system, upper tier floor and ceiling systems that are similar to that indicated for this project in material, design, and extent. This engineer's responsibilities shall include the integration of other structural elements indicated on the drawings (i.e. upper cell tier stairs and support elements) with the steel detention wall panel system, upper cell tier floor system and upper cell tier ceiling system.
- B. Single-Source Responsibility: All materials for steel detention wall panel and ceiling systems to be furnished by a single manufacturer.
- C. Manufacturer's Qualifications:
1. Evidence of a minimum of five (5) years of experience in successfully completing projects of equal or greater size and magnitude. Evidence shall consist of a list of five (5) new detention or corrections projects of at least 200 cells completed and operational for a minimum of two (2) years. Experience shall be for the Panel Manufacturer as a legal entity only. Experience of individuals employed by the Panel Manufacturer who were previously employed by another entity, shall not be used to establish the respondent entity's level of experience.
 2. For each project listed, include name and location of the facility, number of cells, value of the Panel Manufacturer's contract, date of occupancy by the Owner, and the name, address and telephone number of the Owner's Representative, Architect, Construction Manager, and/or General Contractor.
 3. Name and address of the respondent Security Metal Wall Panel Manufacturer. Identify whether the respondent firm is a sole legal entity or is a subsidiary of a parent company, and identity of the parent company.
 4. Provide statement indicating the Panel Manufacturer has not filed for bankruptcy protection within the past ten (10) years.
 5. Submit an original letter certifying that the Panel Manufacturer will have an on-site factory technician who shall oversee the progress and completed installation.
 6. All submittal requirements as stated above shall apply to a single legal entity responding as the Security Metal Wall Panel Manufacturer. Responses from joint ventures, associations or any teaming efforts will be considered only if each legal entity of the joint venture, association, or teaming effort fully complies with the submittal requirements as stated above.
- D. Quality Criteria

1. All panel construction shall be in accordance with construction of assemblies which meet the requirements of specification.
2. Manufacturer shall provide evidence of having personnel and plant equipment capable of fabricating hollow metal wall panel assemblies of the type specified. Manufacturer shall provide current documentation of the number of employees, a listing of their production equipment, and a description of their manufacturing facility.
3. Manufacturers shall be ISO 9001:2008 certified and shall be required to present their Certificate of Registration upon request of the owner and/or AE. The manufacturer's ISO registrar shall be nationally recognized and accredited registrar, which provides periodic factory follow-up audits reaffirming the manufacturer's continuing compliance with their certified Quality Management System.
4. Manufacturer's production welders shall be qualified under AWS D1.3 and upon request shall provide copies of Welders Certifications in accordance with AWD D1.3.
5. Fabrication methods and product quality shall meet standards set by the Hollow Metal Manufacturers Association, HMMA, a Division of the National Association of Architectural Metal Manufacturers, NAAMM, as set forth in these specifications.
6. Job Site Panel Check
At the owner's option, a panel at the job site shall be selected at random and sawed in half or otherwise taken apart as deemed necessary for verification that construction is in accordance with these specifications. The manufacturer shall include the cost of the replacement panel in his quotation. If the panel construction does not conform to these specifications, the non-conforming panels shall be repaired or replaced at the manufacturer's expense.

E. Acceptable Manufacturers

1. Trussbilt, LLC -New Brighton, MN. Phone: 651.633.6100, Fax: 651.628.9482, Website: www.trussbilt.com
2. Habersham Metal Products Company – Cornelia, GA. Phone 706.778.2212, Fax: 706.778.2769, Website: www.habershammetal.com
3. Approved Equal, meeting the qualifications noted in this specification section.
4. Note: Pre-Qualifications are not to be acceptance of the manufacturer's standard product. Pre-Qualification is only approval to manufacture and supply the products meeting this specification.

1.7 SUBMITTALS

- A. Test Report: Manufacturer shall submit to the owner and architect, ten (10) days prior to bid date, an independent testing laboratory reports certifying that products meet all test requirements set forth above.

- B. Qualifications: Manufacturer shall submit to the owner, ten (10) days prior to bid date, qualifications as required by the "Qualifications" paragraph above.
- C. Engineering Documentation: Manufacturer shall provide certification by an independent professional engineering firm documenting the required welding schedule for the panels, floor channels, and the like, and establishing required ceiling/mezzanine structures. Engineering documentation shall address compliance with structural requirements and seismic issues and bear the Professional Seal of said Engineer.
- D. Detail Drawings: Provide copies of Engineering Drawings indicating construction method employed and typical field installation methods.
- E. Shop drawings, prepared under the supervision of a qualified professional engineer, detailing fabrication and installation of steel detention wall panel system specified herein, including the upper tier floor and ceiling systems, to include the following:
 - 1. Erection Drawings:
 - a. Field installed anchor location drawings. Anchor location drawings shall be separately submitted at least two weeks prior to placing concrete in post-tensioning slab.
 - b. Plans and/or elevations locating and defining all materials furnished and installed by manufacturer.
 - c. Sections and details showing connections, joints, built-in items and their relation to the structure.
 - d. Description of all loose, built-in and field hardware.
 - e. Erection sequences and handling requirements.
 - f. All dead, live, seismic, and other applicable loads used in the design.
 - 2. Production Drawings:
 - a. For each different module type:
 - i. Elevation views for each type of cell module, showing locations of inserts, furnishings, back boxes, light, doors, toilet accessories, etc.
 - ii. Sections and details to indicate quantities and position of anchors, inserts, etc.
 - iii. Dimensions and finishes.

1.8 WARRANTY

- A. All panels shall be warranted from defects in workmanship and quality for a period of five years from date of Substantial Completion.

1.9 DELIVERY, STORAGE AND HANDLING

- A. Packing and Marking: Mark each piece according to the approved erection

drawings.

- B. Inspect all components upon delivery for damage. Damages may be repaired, provided the finish items are equal in all respects to new work and acceptable to the Architect; otherwise, remove and replace damaged items as directed.
- C. Store all components at the building site under cover. Do not store any materials directly on the ground or concrete. Provide adequate ventilation and protection to insure materials are kept dry, clean and secure. Store all materials in the manner and order as prescribed by the manufacturer.

PART 2 - PRODUCTS

2.1 HOLLOW METAL WALL PANELS

A. General:

- 1. Factory fabrication of wall panel system, mounting and finishing channels, angles and plates. Panels shall be factory prepared and reinforced to receive template, specified equipment. Prime paint exposed surface of panels.
- 2. Furnish mounting channels, corner plates, closure plates as necessary for sub-contractor to install panel system.

A. Materials

- 1. Panel face sheets, mounting angles, channels and cover plates shall be constructed of 0.093 in. (2.3 mm) minimum thickness and shall have a zinc coating applied by the hot-dip process conforming to ASTM A 653/A 653M Commercial Steel (CS), coating designation A60 (Z180) or Type 304 stainless steel as indicated on Drawings. The steel shall be free of scale, pitting, coil breaks or other surface blemishes. It shall also be free of buckles, waves or any other defects caused by the use of improperly leveled sheets.
- 2. Floor mounting channels shall be constructed of 0.093 in. (2.3 mm) minimum thickness stainless steel meeting ASTM A 666, Type 304. Mounting channels and angles will be anchored at no less than 16 in. (406.4 mm) O.C.
- 3. All panels shall be fully fire retardant foam filled in the manufacturer's plant. Foam fill specifications shall be the manufacturer's proprietary design which meets or exceeds the structural and seismic requirements, fire resistance and STC ratings specified for this project.
- 4. Fire rated panels shall be grout filled to meet fire resistance rating requirements indicated in the drawings. Grout design will be compatible with wall panel system and shall not cause any deterioration of the wall panel system.

B. Construction

1. All panels shall be of the types and sizes shown on the approved submittal drawings, shall be constructed in accordance with the specifications, and shall meet the performance requirements of Article "TESTING AND PERFORMANCE", where applicable.
2. Panel face sheets shall be joined at their vertical edges by a continuous rabbeted joint extending the full height of the panel.
3. Panel thickness shall be 2 in. (50 mm) minimum. Panels shall be neat in appearance and free from warpage or buckle. Edge bends shall be true and straight and of minimum radius for the thickness of material used.
4. Panels shall be stiffened by one of the following systems:
 - a. Continuous steel truss design core material, .015 in (.4 mm) minimum, having truncated triangular sections extending continuously from one panel face to the other, spot weld to each face sheet 2 ¾ in. (69,9 mm) O.C. horizontally and 3 in. (76.2 mm) O.C. vertically. Core material shall extend full height and width of panel.
 - b. Rolled or formed 1/8 in. (3.2 mm) steel channels extending from top to bottom of panel and continuous from one face to the other, spaced not more than 4 in. (101.6 mm) O.C. and spot welded to panel faces not more than 3 in. (76.2 mm) O.C. vertically. The formed channels are to be welded on both sides of the channel with 1 in. (25.4 mm) welds spaced at not less than 8 in. (203.2 mm) O.C. vertically.
5. Door frames, Widows, Vents
 - a. Where specified, panels shall be provided with cutouts reinforced with steel moldings, not less than 0.093 in. (2.3 mm) to secure door frames, windows, and air venting grills in accordance with sizes shown on the contract drawings.

2.2 WALL PANEL FINISH

- A. After fabrication, all tool marks and surface imperfections shall be filled and sanded as required to make face sheets, vertical edges and weld joints free from irregularities.
- B. Prime painting: All steel panels will be primed with a catalyzed primer. The use of an alkyd primer will not be allowed for any metal wall panel primer or any security hollow metal primer attached to the metal wall panel system.
- C. In order to prevent removal of zinc galvanizing material from panel surfaces, panels shall not be finish sanded on panel surfaces. Light, visible spot welding marks from the fabrication process will be visible after finish painting and shall not be deemed cause for rejection of panel surfaces.

PART 3 -EXECUTION

3.1 SITE STORAGE AND PROTECTION OF MATERIALS

- A. The contractor shall remove wraps or covers from panels, doors, frames, and cell furnishings upon delivery at the building site. The contractor shall see that any scratches or disfigurement caused in shipping or handling are promptly sanded smooth, cleaned and touched up with a compatible rust inhibitive primer and/or factory finished surface as required and acceptable to the owner.
- B. The contractor shall see that materials are properly stored on planks or dunnage in a dry location. Panels shall be stored in a horizontal position and spaced by blocking. Materials shall be covered to protect them from damage but in such a manner as to permit air circulation.

3.2 INSTALLATION

- A. The Contractor responsible for installation shall coordinate and perform the following:
 - 1. Prior to installation, all panels, mounting channels and angles shall be checked for size and staged at the appropriate locations.
 - 2. Stitch weld panels to floor channels and wall and ceiling mounting angles as required by engineering documentation and manufacturer's recommendations. Caulk between welds using a two-part epoxy caulk, Pecora Pick Proof Caulk or equivalent (refer to specification for joint sealants). Exposed field welds shall be finished smooth and touched up with a rust inhibitive primer and repainted to match surrounding surfaces.
 - 3. Primed or painted surfaces which have been scratched or otherwise marred during installation (including field welding) and/or cleaning shall promptly be finished smooth, cleaned, treated for maximum paint adhesion and touched up with a rust inhibitive primer comparable and compatible to shop applied primer.
 - 4. Clean and remove debris, leaving cells ready for installation of plumbing, electrical, heating/ventilating, furniture and other trades or materials.

END OF SECTION 111990

SECTION 230513

COMMON MOTOR REQUIREMENTS FOR HVAC EQUIPMENT

PART 1 - GENERAL

1.1 RELATED DOCUMENTS

- A. Drawings and general provisions of the Contract, including General and Supplementary Conditions and Division 01 Specification Sections, apply to this Section.

1.2 SUMMARY

- A. Section includes general requirements for single-phase and polyphase, general-purpose, horizontal, small and medium, squirrel-cage induction motors for use on ac power systems up to 600 V and installed at equipment manufacturer's factory or shipped separately by equipment manufacturer for field installation.

1.3 COORDINATION

- A. Coordinate features of motors, installed units, and accessory devices to be compatible with the following:
 - 1. Motor controllers.
 - 2. Torque, speed, and horsepower requirements of the load.
 - 3. Ratings and characteristics of supply circuit and required control sequence.
 - 4. Ambient and environmental conditions of installation location.

PART 2 - PRODUCTS

2.1 GENERAL MOTOR REQUIREMENTS

- A. Comply with NEMA MG 1 unless otherwise indicated.
- B. Comply with IEEE 841 for severe-duty motors.

2.2 MOTOR CHARACTERISTICS

- A. Duty: Continuous duty at ambient temperature of 40 deg C and at altitude of 3300 feet above sea level.

- B. Capacity and Torque Characteristics: Sufficient to start, accelerate, and operate connected loads at designated speeds, at installed altitude and environment, with indicated operating sequence, and without exceeding nameplate ratings or considering service factor.

2.3 POLYPHASE MOTORS

- A. Description: NEMA MG 1, Design B, medium induction motor.
- B. Efficiency: Energy efficient, as defined in NEMA MG 1.
- C. Service Factor: 1.15.
- D. Multispeed Motors: Variable torque.
 - 1. For motors with 2:1 speed ratio, consequent pole, single winding.
 - 2. For motors with other than 2:1 speed ratio, separate winding for each speed.
- E. Multispeed Motors: Separate winding for each speed.
- F. Rotor: Random-wound, squirrel cage.
- G. Bearings: Re-greasable, shielded, antifriction ball bearings suitable for radial and thrust loading.
- H. Temperature Rise: Match insulation rating.
- I. Insulation: Class F.
- J. Code Letter Designation:
 - 1. Motors Smaller than 15 HP: Manufacturer's standard starting characteristic.
- K. Enclosure Material: Cast iron for motor frame sizes 324T and larger; rolled steel for motor frame sizes smaller than 324T.

2.4 POLYPHASE MOTORS WITH ADDITIONAL REQUIREMENTS

- A. Motors Used with Reduced-Voltage and Multispeed Controllers: Match wiring connection requirements for controller with required motor leads. Provide terminals in motor terminal box, suited to control method.
- B. Motors Used with Variable Frequency Controllers: Ratings, characteristics, and features coordinated with and approved by controller manufacturer.
 - 1. Windings: Copper magnet wire with moisture-resistant insulation varnish, designed and tested to resist transient spikes, high frequencies, and short time rise pulses produced by pulse-width modulated inverters.

2. Energy- and Premium-Efficient Motors: Class B temperature rise; Class F insulation.
 3. Inverter-Duty Motors: Class F temperature rise; Class H insulation.
 4. Thermal Protection: Comply with NEMA MG 1 requirements for thermally protected motors.
- C. Severe-Duty Motors: Comply with IEEE 841, with 1.15 minimum service factor.

2.5 SINGLE-PHASE MOTORS

- A. Motors larger than 1/20 hp shall be one of the following, to suit starting torque and requirements of specific motor application:
1. Permanent-split capacitor.
 2. Split phase.
 3. Capacitor start, inductor run.
 4. Capacitor start, capacitor run.
- B. Multispeed Motors: Variable-torque, permanent-split-capacitor type.
- C. Bearings: Prelubricated, antifriction ball bearings or sleeve bearings suitable for radial and thrust loading.
- D. Motors 1/20 HP and Smaller: Shaded-pole type.
- E. Thermal Protection: Internal protection to automatically open power supply circuit to motor when winding temperature exceeds a safe value calibrated to temperature rating of motor insulation. Thermal-protection device shall automatically reset when motor temperature returns to normal range.

PART 3 - EXECUTION (Not Applicable)

END OF SECTION 230513

SECTION 230519

METERS AND GAGES FOR HVAC PIPING

PART 1 - GENERAL

1.1 RELATED DOCUMENTS

- A. Drawings and general provisions of the Contract, including General and Supplementary Conditions and Division 01 Specification Sections, apply to this Section.

1.2 SUMMARY

- A. Section Includes:
 - 1. Dial-type pressure gages.
 - 2. Gage attachments.

1.3 ACTION SUBMITTALS

- A. Product Data: For each type of product indicated.
- B. Wiring Diagrams: For power, signal, and control wiring.

1.4 INFORMATIONAL SUBMITTALS

- A. Product Certificates: For each type of meter and gage, from manufacturer.

1.5 CLOSEOUT SUBMITTALS

- A. Operation and Maintenance Data: For meters and gages to include in operation and maintenance manuals.

PART 2 - PRODUCTS

2.1 PRESSURE GAGES

- A. Direct-Mounted, Metal-Case, Dial-Type Pressure Gages:

1. Manufacturers: Subject to compliance with requirements, available manufacturers offering products that may be incorporated into the Work include, but are not limited to, the following:
 - a. AMETEK, Inc.; U.S. Gauge.
 - b. Ashcroft Inc.
 - c. Ernst Flow Industries.
 - d. Flo Fab Inc.
 - e. Marsh Bellofram.
 - f. Miljoco Corporation.
 - g. Noshok.
 - h. Palmer Wahl Instrumentation Group.
 - i. REOTEMP Instrument Corporation.
 - j. Tel-Tru Manufacturing Company.
 - k. Trevice, H. O. Co.
 - l. Watts Regulator Co.; a div. of Watts Water Technologies, Inc.
 - m. Weiss Instruments, Inc.
 - n. WIKA Instrument Corporation - USA.
 - o. Winters Instruments - U.S.
2. Standard: ASME B40.100.
3. Case: Sealed type; cast aluminum or drawn steel; 6-inch nominal diameter.
4. Pressure-Element Assembly: Bourdon tube unless otherwise indicated.
5. Pressure Connection: Brass, with NPS 1/2, ASME B1.20.1 pipe threads and bottom-outlet type unless back-outlet type is indicated.
6. Movement: Mechanical, with link to pressure element and connection to pointer.
7. Dial: Non-reflective aluminum with permanently etched scale markings graduated in psi.
8. Pointer: Dark-colored metal.
9. Window: Glass or plastic.
10. Ring: Brass.
11. Accuracy: Grade A, plus or minus 1 percent of middle half of scale range.

2.2 GAGE ATTACHMENTS

- A. Snubbers: ASME B40.100, brass; with NPS 1/2, ASME B1.20.1 pipe threads and piston-type surge-dampening device. Include extension for use on insulated piping.
- B. Siphons: Loop-shaped section of steel pipe with NPS 1/2 pipe threads.
- C. Valves: Brass or stainless-steel needle, with NPS 1/2, ASME B1.20.1 pipe threads.

PART 3 - EXECUTION

3.1 INSTALLATION

- A. Install direct-mounted pressure gages in piping tees with pressure gage located on pipe at the most readable position.
- B. Install valve and snubber in piping for each pressure gage for fluids (except steam).
- C. Install valve and syphon fitting in piping for each pressure gage for steam.
- D. Install pressure gages in the following locations:
 - 1. Discharge of each pressure-reducing valve.

3.2 CONNECTIONS

- A. Install meters and gages adjacent to machines and equipment to allow service and maintenance of meters, gages, machines, and equipment.

3.3 ADJUSTING

- A. Adjust faces of gages to proper angle for best visibility.

3.4 PRESSURE-GAGE SCHEDULE

- A. Pressure gages at discharge of each pressure-reducing valve shall be the following:
 - 1. Sealed, direct-mounted, metal case.

3.5 PRESSURE-GAGE SCALE-RANGE SCHEDULE

- A. Scale Range for Steam Piping: 0 to 200 psi.

END OF SECTION 230519

SECTION 230523

GENERAL-DUTY VALVES FOR HVAC PIPING

PART 1 - GENERAL

1.1 RELATED DOCUMENTS

- A. Drawings and general provisions of the Contract, including General and Supplementary Conditions and Division 01 Specification Sections, apply to this Section.

1.2 SUMMARY

- A. Section Includes:

- 1. Bronze swing check valves.
- 2. Iron swing check valves.
- 3. Bronze gate valves.
- 4. Iron gate valves.
- 5. Bronze globe valves.
- 6. Iron globe valves.

- B. Related Sections:

- 1. Section 230553 "Identification for HVAC Piping and Equipment" for valve tags and schedules.

1.3 DEFINITIONS

- A. CWP: Cold working pressure.
- B. EPDM: Ethylene propylene copolymer rubber.
- C. NBR: Acrylonitrile-butadiene, Buna-N, or nitrile rubber.
- D. NRS: Nonrising stem.
- E. OS&Y: Outside screw and yoke.
- F. RS: Rising stem.
- G. SWP: Steam working pressure.

1.4 ACTION SUBMITTALS

- A. Product Data: For each type of valve indicated.

1.5 QUALITY ASSURANCE

- A. Source Limitations for Valves: Obtain each type of valve from single source from single manufacturer.
- B. ASME Compliance:
 - 1. ASME B16.10 and ASME B16.34 for ferrous valve dimensions and design criteria.
 - 2. ASME B31.1 for power piping valves.
 - 3. ASME B31.9 for building services piping valves.

1.6 DELIVERY, STORAGE, AND HANDLING

- A. Prepare valves for shipping as follows:
 - 1. Protect internal parts against rust and corrosion.
 - 2. Protect threads, flange faces, grooves, and weld ends.
 - 3. Set angle, gate, and globe valves closed to prevent rattling.
 - 4. Set ball and plug valves open to minimize exposure of functional surfaces.
 - 5. Set butterfly valves closed or slightly open.
 - 6. Block check valves in either closed or open position.
- B. Use the following precautions during storage:
 - 1. Maintain valve end protection.
 - 2. Store valves indoors and maintain at higher than ambient dew point temperature. If outdoor storage is necessary, store valves off the ground in watertight enclosures.
- C. Use sling to handle large valves; rig sling to avoid damage to exposed parts. Do not use handwheels or stems as lifting or rigging points.

PART 2 - PRODUCTS

2.1 GENERAL REQUIREMENTS FOR VALVES

- A. Refer to HVAC valve schedule articles for applications of valves.
- B. Valve Pressure and Temperature Ratings: Not less than indicated and as required for system pressures and temperatures.
- C. Valve Sizes: Same as upstream piping unless otherwise indicated.

D. Valve Actuator Types:

1. Gear Actuator: For quarter-turn valves NPS 8 and larger.
2. Handwheel: For valves other than quarter-turn types.
3. Handlever: For quarter-turn valves NPS 6 and smaller.
4. Chainwheel: Device for attachment to valve handwheel, stem, or other actuator; of size and with chain for mounting height, as indicated in the "Valve Installation" Article.

E. Valves in Insulated Piping: With 2-inch stem extensions and the following features:

1. Gate Valves: With rising stem.
2. Ball Valves: With extended operating handle of non-thermal-conductive material, and protective sleeve that allows operation of valve without breaking the vapor seal or disturbing insulation.
3. Butterfly Valves: With extended neck.

F. Valve-End Connections:

1. Flanged: With flanges according to ASME B16.1 for iron valves.
2. Grooved: With grooves according to AWWA C606.
3. Solder Joint: With sockets according to ASME B16.18.
4. Threaded: With threads according to ASME B1.20.1.

G. Valve Bypass and Drain Connections: MSS SP-45.

2.2 BRONZE SWING CHECK VALVES

A. Class 150, Bronze Swing Check Valves with Bronze Disc:

1. Manufacturers: Subject to compliance with requirements, available manufacturers offering products that may be incorporated into the Work include, but are not limited to, the following:
 - a. American Valve, Inc.
 - b. Crane Co.; Crane Valve Group; Crane Valves.
 - c. Crane Co.; Crane Valve Group; Jenkins Valves.
 - d. Crane Co.; Crane Valve Group; Stockham Division.
 - e. Kitz Corporation.
 - f. Milwaukee Valve Company.
 - g. NIBCO INC.
 - h. Red-White Valve Corporation.
 - i. Zy-Tech Global Industries, Inc.
2. Description:
 - a. Standard: MSS SP-80, Type 3.
 - b. CWP Rating: 300 psig.
 - c. Body Design: Horizontal flow.

- d. Body Material: ASTM B 62, bronze.
- e. Ends: Threaded.
- f. Disc: Bronze.

2.3 IRON SWING CHECK VALVES

A. Class 250, Iron Swing Check Valves with Metal Seats:

1. Manufacturers: Subject to compliance with requirements, available manufacturers offering products that may be incorporated into the Work include, but are not limited to, the following:
 - a. Crane Co.; Crane Valve Group; Crane Valves.
 - b. Crane Co.; Crane Valve Group; Jenkins Valves.
 - c. Crane Co.; Crane Valve Group; Stockham Division.
 - d. Hammond Valve.
 - e. Milwaukee Valve Company.
 - f. NIBCO INC.
 - g. Watts Regulator Co.; a division of Watts Water Technologies, Inc.
2. Description:
 - a. Standard: MSS SP-71, Type I.
 - b. NPS 2-1/2 to NPS 12, CWP Rating: 500 psig.
 - c. Body Design: Clear or full waterway.
 - d. Body Material: ASTM A 126, gray iron with bolted bonnet.
 - e. Ends: Flanged.
 - f. Trim: Bronze.
 - g. Gasket: Asbestos free.

2.4 BRONZE GATE VALVES

A. Class 150, NRS Bronze Gate Valves:

1. Manufacturers: Subject to compliance with requirements, available manufacturers offering products that may be incorporated into the Work include, but are not limited to, the following:
 - a. Hammond Valve.
 - b. Kitz Corporation.
 - c. Milwaukee Valve Company.
 - d. NIBCO INC.
 - e. Powell Valves.
 - f. Red-White Valve Corporation.
 - g. Watts Regulator Co.; a division of Watts Water Technologies, Inc.
2. Description:

- a. Standard: MSS SP-80, Type 1.
- b. CWP Rating: 300 psig.
- c. Body Material: ASTM B 62, bronze with integral seat and union-ring bonnet.
- d. Ends: Threaded.
- e. Stem: Bronze.
- f. Disc: Solid wedge; bronze.
- g. Packing: Asbestos free.
- h. Handwheel: Malleable iron.

2.5 IRON GATE VALVES

A. Class 250, NRS, Iron Gate Valves:

1. Manufacturers: Subject to compliance with requirements, available manufacturers offering products that may be incorporated into the Work include, but are not limited to, the following:
 - a. Crane Co.; Crane Valve Group; Crane Valves.
 - b. Crane Co.; Crane Valve Group; Stockham Division.
 - c. NIBCO INC.
2. Description:
 - a. Standard: MSS SP-70, Type I.
 - b. NPS 2-1/2 to NPS 12, CWP Rating: 500 psig.
 - c. Body Material: ASTM A 126, gray iron with bolted bonnet.
 - d. Ends: Flanged.
 - e. Trim: Bronze.
 - f. Disc: Solid wedge.
 - g. Packing and Gasket: Asbestos free.

2.6 BRONZE GLOBE VALVES

A. Class 150, Bronze Globe Valves with Nonmetallic Disc:

1. Manufacturers: Subject to compliance with requirements, available manufacturers offering products that may be incorporated into the Work include, but are not limited to, the following:
 - a. Crane Co.; Crane Valve Group; Crane Valves.
 - b. Hammond Valve.
 - c. Kitz Corporation.
 - d. Milwaukee Valve Company.
 - e. NIBCO INC.
 - f. Powell Valves.
 - g. Red-White Valve Corporation.
 - h. Watts Regulator Co.; a division of Watts Water Technologies, Inc.

- i. Zy-Tech Global Industries, Inc.
- 2. Description:
 - a. Standard: MSS SP-80, Type 2.
 - b. CWP Rating: 300 psig.
 - c. Body Material: ASTM B 62, bronze with integral seat and union-ring bonnet.
 - d. Ends: Threaded.
 - e. Stem: Bronze.
 - f. Disc: PTFE or TFE.
 - g. Packing: Asbestos free.
 - h. Handwheel: Malleable iron.

2.7 IRON GLOBE VALVES

A. Class 250, Iron Globe Valves:

- 1. Manufacturers: Subject to compliance with requirements, available manufacturers offering products that may be incorporated into the Work include, but are not limited to, the following:
 - a. Crane Co.; Crane Valve Group; Crane Valves.
 - b. Crane Co.; Crane Valve Group; Jenkins Valves.
 - c. Crane Co.; Crane Valve Group; Stockham Division.
 - d. Hammond Valve.
 - e. Milwaukee Valve Company.
 - f. NIBCO INC.
 - g. Watts Regulator Co.; a division of Watts Water Technologies, Inc.
- 2. Description:
 - a. Standard: MSS SP-85, Type I.
 - b. CWP Rating: 500 psig.
 - c. Body Material: ASTM A 126, gray iron with bolted bonnet.
 - d. Ends: Flanged.
 - e. Trim: Bronze.
 - f. Packing and Gasket: Asbestos free.

PART 3 - EXECUTION

3.1 EXAMINATION

- A. Examine valve interior for cleanliness, freedom from foreign matter, and corrosion. Remove special packing materials, such as blocks, used to prevent disc movement during shipping and handling.

- B. Operate valves in positions from fully open to fully closed. Examine guides and seats made accessible by such operations.
- C. Examine threads on valve and mating pipe for form and cleanliness.
- D. Examine mating flange faces for conditions that might cause leakage. Check bolting for proper size, length, and material. Verify that gasket is of proper size, that its material composition is suitable for service, and that it is free from defects and damage.
- E. Do not attempt to repair defective valves; replace with new valves.

3.2 VALVE INSTALLATION

- A. Install valves with unions or flanges at each piece of equipment arranged to allow service, maintenance, and equipment removal without system shutdown.
- B. Locate valves for easy access and provide separate support where necessary.
- C. Install valves in horizontal piping with stem at or above center of pipe.
- D. Install valves in position to allow full stem movement.
- E. Install check valves for proper direction of flow and as follows:
 - 1. Swing Check Valves: In horizontal position with hinge pin level.

3.3 ADJUSTING

- A. Adjust or replace valve packing after piping systems have been tested and put into service but before final adjusting and balancing. Replace valves if persistent leaking occurs.

3.4 GENERAL REQUIREMENTS FOR VALVE APPLICATIONS

- A. If valve applications are not indicated, use the following:
 - 1. Shutoff Service: Gate valves.
- B. If valves with specified SWP classes or CWP ratings are not available, the same types of valves with higher SWP classes or CWP ratings may be substituted.
- C. Select valves, except wafer types, with the following end connections:
 - 1. For Steel Piping, NPS 2 and Smaller: Threaded ends.
 - 2. For Steel Piping, NPS 2-1/2 to NPS 4: Flanged ends except where threaded valve-end option is indicated in valve schedules below.

3.5 HIGH-PRESSURE STEAM VALVE SCHEDULE (MORE THAN 15 PSIG)

- A. Pipe NPS 2 and Smaller:
 - 1. Bronze Swing Check Valves: Class 150, bronze disc.
 - 2. Bronze Gate Valves: Class 150, NRS, bronze.
 - 3. Globe Valves: Class 150, bronze, bronze disc.

- B. Pipe Sizes NPS 2-1/2 and Larger:
 - 1. Iron Swing Check Valves: Class 250, metal seats.
 - 2. Iron Gate Valves: Class 250, NRS.
 - 3. Iron Globe Valves, NPS 2-1/2 to NPS 12: Class 250.

3.6 STEAM-CONDENSATE VALVE SCHEDULE

- A. Pipe NPS 2 and Smaller:
 - 1. Bronze Swing Check Valves: Class 150, bronze disc.
 - 2. Bronze Gate Valves: Class 150, NRS.

- B. Pipe NPS 2-1/2 and Larger:
 - 1. Iron Swing Check Valves: Class 250, metal seats.
 - 2. Iron Gate Valves: Class 250, NRS.

END OF SECTION 230523

SECTION 230529

HANGERS AND SUPPORTS FOR HVAC PIPING AND EQUIPMENT

PART 1 - GENERAL

1.1 RELATED DOCUMENTS

- A. Drawings and general provisions of the Contract, including General and Supplementary Conditions and Division 01 Specification Sections, apply to this Section.

1.2 SUMMARY

- A. Section Includes:
 - 1. Metal pipe hangers and supports.
 - 2. Fastener systems.

1.3 DEFINITIONS

- A. MSS: Manufacturers Standardization Society of The Valve and Fittings Industry Inc.

1.4 ACTION SUBMITTALS

- A. Product Data: For each type of product indicated.

1.5 INFORMATIONAL SUBMITTALS

- A. Welding certificates.

1.6 QUALITY ASSURANCE

- A. Structural Steel Welding Qualifications: Qualify procedures and personnel according to AWS D1.1/D1.1M, "Structural Welding Code - Steel."
- B. Pipe Welding Qualifications: Qualify procedures and operators according to ASME Boiler and Pressure Vessel Code.

PART 2 - PRODUCTS

2.1 METAL PIPE HANGERS AND SUPPORTS

A. Carbon-Steel Pipe Hangers and Supports:

1. Description: MSS SP-58, Types 1 through 58, factory-fabricated components.
2. Galvanized Metallic Coatings: Pregalvanized or hot dipped.
3. Nonmetallic Coatings: Plastic coating, jacket, or liner.
4. Padded Hangers: Hanger with fiberglass or other pipe insulation pad or cushion to support bearing surface of piping.
5. Hanger Rods: Continuous-thread rod, nuts, and washer made of carbon steel.

2.2 FASTENER SYSTEMS

- A. Powder-Actuated Fasteners: Threaded-steel stud, for use in hardened portland cement concrete with pull-out, tension, and shear capacities appropriate for supported loads and building materials where used.
- B. Mechanical-Expansion Anchors: Insert-wedge-type, zinc-coated steel anchors, for use in hardened portland cement concrete; with pull-out, tension, and shear capacities appropriate for supported loads and building materials where used.

2.3 MISCELLANEOUS MATERIALS

- A. Structural Steel: ASTM A 36/A 36M, carbon-steel plates, shapes, and bars; black and galvanized.

PART 3 - EXECUTION

3.1 HANGER AND SUPPORT INSTALLATION

- A. Metal Pipe-Hanger Installation: Comply with MSS SP-69 and MSS SP-89. Install hangers, supports, clamps, and attachments as required to properly support piping from the building structure.
- B. Fastener System Installation:
 1. Install powder-actuated fasteners for use in lightweight concrete or concrete slabs less than 4 inches thick in concrete after concrete is placed and completely cured. Use operators that are licensed by powder-actuated tool manufacturer. Install fasteners according to powder-actuated tool manufacturer's operating manual.

2. Install mechanical-expansion anchors in concrete after concrete is placed and completely cured. Install fasteners according to manufacturer's written instructions.
- C. Install hangers and supports complete with necessary attachments, inserts, bolts, rods, nuts, washers, and other accessories.
- D. Install hangers and supports to allow controlled thermal movement of piping systems, to permit freedom of movement between pipe anchors, and to facilitate action of expansion joints, expansion loops, expansion bends, and similar units.
- E. Install lateral bracing with pipe hangers and supports to prevent swaying.
- F. Load Distribution: Install hangers and supports so that piping live and dead loads and stresses from movement will not be transmitted to connected equipment.
- G. Pipe Slopes: Install hangers and supports to provide indicated pipe slopes and to not exceed maximum pipe deflections allowed by ASME B31.9 for building services piping.
- H. Insulated Piping:
 1. Attach clamps and spacers to piping.
 - a. Piping Operating above Ambient Air Temperature: Clamp may project through insulation.
 - b. Piping Operating below Ambient Air Temperature: Use thermal-hanger shield insert with clamp sized to match OD of insert.
 - c. Do not exceed pipe stress limits allowed by ASME B31.9 for building services piping.
 2. Install MSS SP-58, Type 39, protection saddles if insulation without vapor barrier is indicated. Fill interior voids with insulation that matches adjoining insulation.
 3. Shield Dimensions for Pipe: Not less than the following:
 - a. NPS 1/4 to NPS 3-1/2: 12 inches long and 0.048 inch thick.
 - b. NPS 4: 12 inches long and 0.06 inch thick.
 - c. NPS 5 and NPS 6: 18 inches long and 0.06 inch thick.

3.2 METAL FABRICATIONS

- A. Fit exposed connections together to form hairline joints. Field weld connections that cannot be shop welded because of shipping size limitations.
- B. Field Welding: Comply with AWS D1.1/D1.1M procedures for shielded, metal arc welding; appearance and quality of welds; and methods used in correcting welding work; and with the following:

1. Use materials and methods that minimize distortion and develop strength and corrosion resistance of base metals.
2. Obtain fusion without undercut or overlap.
3. Remove welding flux immediately.
4. Finish welds at exposed connections so no roughness shows after finishing and so contours of welded surfaces match adjacent contours.

3.3 ADJUSTING

- A. Hanger Adjustments: Adjust hangers to distribute loads equally on attachments and to achieve indicated slope of pipe.
- B. Trim excess length of continuous-thread hanger and support rods to 1-1/2 inches.

3.4 PAINTING

- A. Touchup: Clean field welds and abraded areas of shop paint. Paint exposed areas immediately after erecting hangers and supports. Use same materials as used for shop painting. Comply with SSPC-PA 1 requirements for touching up field-painted surfaces.
 1. Apply paint by brush or spray to provide a minimum dry film thickness of 2.0 mils.
- B. Touchup: Cleaning and touchup painting of field welds, bolted connections, and abraded areas of shop paint on miscellaneous metal are specified in Section 099123 "Interior Painting"
- C. Galvanized Surfaces: Clean welds, bolted connections, and abraded areas and apply galvanizing-repair paint to comply with ASTM A 780.

3.5 HANGER AND SUPPORT SCHEDULE

- A. Specific hanger and support requirements are in Sections specifying piping systems and equipment.
- B. Comply with MSS SP-69 for pipe-hanger selections and applications that are not specified in piping system Sections.
- C. Use hangers and supports with galvanized metallic coatings for piping and equipment that will not have field-applied finish.
- D. Use nonmetallic coatings on attachments for electrolytic protection where attachments are in direct contact with copper tubing.
- E. Use carbon-steel pipe hangers and supports and attachments for general service applications.

- F. Horizontal-Piping Hangers and Supports: Unless otherwise indicated and except as specified in piping system Sections, install the following types:
 - 1. Adjustable, Steel Clevis Hangers (MSS Type 1): For suspension of noninsulated or insulated, stationary pipes NPS 1/2 to NPS 30.
- G. Hanger-Rod Attachments: Unless otherwise indicated and except as specified in piping system Sections, install the following types:
 - 1. Steel Turnbuckles (MSS Type 13): For adjustment up to 6 inches for heavy loads.
 - 2. Steel Clevises (MSS Type 14): For 120 to 450 deg F piping installations.
- H. Saddles and Shields: Unless otherwise indicated and except as specified in piping system Sections, install the following types:
 - 1. Steel-Pipe-Covering Protection Saddles (MSS Type 39): To fill interior voids with insulation that matches adjoining insulation.
 - 2. Protection Shields (MSS Type 40): Of length recommended in writing by manufacturer to prevent crushing insulation.
- I. Use powder-actuated fasteners or mechanical-expansion anchors instead of building attachments where required in concrete construction.

END OF SECTION 230529

SECTION 230553

IDENTIFICATION FOR HVAC PIPING AND EQUIPMENT

PART 1 - GENERAL

1.1 RELATED DOCUMENTS

- A. Drawings and general provisions of the Contract, including General and Supplementary Conditions and Division 01 Specification Sections, apply to this Section.

1.2 SUMMARY

- A. Section Includes:

- 1. Pipe labels.
- 2. Duct labels.
- 3. Valve tags.

1.3 ACTION SUBMITTALS

- A. Product Data: For each type of product indicated.
- B. Samples: For color, letter style, and graphic representation required for each identification material and device.
- C. Equipment Label Schedule: Include a listing of all equipment to be labeled with the proposed content for each label.
- D. Valve numbering scheme.
- E. Valve Schedules: For each piping system to include in maintenance manuals.

1.4 COORDINATION

- A. Coordinate installation of identifying devices with completion of covering and painting of surfaces where devices are to be applied.
- B. Coordinate installation of identifying devices with locations of access panels and doors.
- C. Install identifying devices before installing acoustical ceilings and similar concealment.

PART 2 - PRODUCTS

2.1 PIPE LABELS

- A. General Requirements for Manufactured Pipe Labels: Preprinted, color-coded, with lettering indicating service, and showing flow direction.
- B. Pre-tensioned Pipe Labels: Pre-coiled, semi-rigid plastic formed to cover full circumference of pipe and to attach to pipe without fasteners or adhesive.
- C. Self-Adhesive Pipe Labels: Printed plastic with contact-type, permanent-adhesive backing.
- D. Pipe Label Contents: Include identification of piping service using same designations or abbreviations as used on Drawings, pipe size, and an arrow indicating flow direction.
 - 1. Flow-Direction Arrows: Integral with piping system service lettering to accommodate both directions, or as separate unit on each pipe label to indicate flow direction.
 - 2. Lettering Size: At least 1-1/2 incheshigh.

2.2 DUCT LABELS

- A. General Requirements for Manufactured Pipe Labels: Preprinted, color-coded, with lettering indicating service, and showing flow direction.
- B. Self-Adhesive Duct Labels: Printed plastic with contact-type, permanent-adhesive backing.
- C. Duct Label Contents: Include identification of duct service using same designations or abbreviations as used on Drawings, duct size, and an arrow indicating flow direction.
 - 1. Flow-Direction Arrows: Integral with duct system service lettering to accommodate both directions, or as separate unit on each duct label to indicate flow direction.
 - 2. Lettering Size: At least 1-1/2 incheshigh.

2.3 VALVE TAGS

- A. Valve Tags: Stamped or engraved with 1/4-inch letters for piping system abbreviation and 1/2-inch numbers.
 - 1. Tag Material: Brass, 0.032-inch minimum thickness, and having predrilled or stamped holes for attachment hardware.
 - 2. Fasteners: Brass wire-link or beaded chain; or S-hook.

- B. Valve Schedules: For each piping system, on 8-1/2-by-11-inch bond paper. Tabulate valve number, piping system, system abbreviation (as shown on valve tag), location of valve (room or space), normal-operating position (open, closed, or modulating), and variations for identification. Mark valves for emergency shutoff and similar special uses.
 - 1. Valve-tag schedule shall be included in operation and maintenance data.

PART 3 - EXECUTION

3.1 PREPARATION

- A. Clean piping and equipment surfaces of substances that could impair bond of identification devices, including dirt, oil, grease, release agents, and incompatible primers, paints, and encapsulants.

3.2 EQUIPMENT LABEL INSTALLATION

- A. Install or permanently fasten labels on each major item of mechanical equipment.
- B. Locate equipment labels where accessible and visible.

3.3 PIPE LABEL INSTALLATION

- A. Locate pipe labels where piping is exposed or above accessible ceilings in finished spaces; machine rooms; accessible maintenance spaces such as shafts, tunnels, and plenums; and exterior exposed locations as follows:
 - 1. Near each valve and control device.
 - 2. Near each branch connection, excluding short takeoffs for fixtures and terminal units. Where flow pattern is not obvious, mark each pipe at branch.
 - 3. Near penetrations through walls, floors, ceilings, and inaccessible enclosures.
 - 4. At access doors, manholes, and similar access points that permit view of concealed piping.
 - 5. Near major equipment items and other points of origination and termination.
 - 6. Spaced at maximum intervals of 50 feet along each run. Reduce intervals to 25 feet in areas of congested piping and equipment.
 - 7. On piping above removable acoustical ceilings. Omit intermediately spaced labels.
- B. Pipe Label Color Schedule: Match existing if different than below.
 - 1. High-Pressure Steam Piping:
 - a. Background Color: Yellow.
 - b. Letter Color: Black.

2. Steam Condensate Piping:
 - a. Background Color: Yellow.
 - b. Letter Color: Black.

3.4 DUCT LABEL INSTALLATION

- A. Install self-adhesive duct labels with permanent adhesive on air ducts in the following color codes:
 1. Green: For exhaust-air ducts.
- B. Locate labels near points where ducts enter into concealed spaces and at maximum intervals of 50 feet in each space where ducts are exposed or concealed by removable ceiling system.

3.5 VALVE-TAG INSTALLATION

- A. Install tags on valves and control devices in piping systems, except check valves; valves within factory-fabricated equipment units; shutoff valves; faucets; convenience and lawn-watering hose connections; and HVAC terminal devices and similar roughing-in connections of end-use fixtures and units. List tagged valves in a valve schedule.
- B. Valve-Tag Application Schedule: Tag valves according to size, shape, and color scheme and with captions similar to those indicated in the following subparagraphs:
 1. Valve-Tag Size and Shape:
 - a. High-Pressure Steam: 2 inches, round.
 - b. Steam Condensate: 2 inches, round.
 2. Valve-Tag Color:
 - a. High-Pressure Steam: Natural.
 - b. Steam Condensate: Natural.
 3. Letter Color:
 - a. High-Pressure Steam: Black.
 - b. Steam Condensate: Black.

3.6 WARNING-TAG INSTALLATION

- A. Write required message on, and attach warning tags to, equipment and other items where required.

END OF SECTION 230553

SECTION 230593

TESTING, ADJUSTING, AND BALANCING FOR HVAC

PART 1 - GENERAL

1.1 RELATED DOCUMENTS

- A. Drawings and general provisions of the Contract, including General and Supplementary Conditions and Division 01 Specification Sections, apply to this Section.

1.2 SUMMARY

- A. Section Includes:
 - 1. Balancing Air Systems:
 - a. Constant-volume air systems.
 - b. Variable-air-volume systems.

1.3 DEFINITIONS

- A. AABC: Associated Air Balance Council.
- B. NEBB: National Environmental Balancing Bureau.
- C. TAB: Testing, adjusting, and balancing.
- D. TABB: Testing, Adjusting, and Balancing Bureau.
- E. TAB Specialist: An entity engaged to perform TAB Work.

1.4 INFORMATIONAL SUBMITTALS

- A. Qualification Data: Within 15 days of Contractor's Notice to Proceed, submit documentation that the TAB contractor and this Project's TAB team members meet the qualifications specified in "Quality Assurance" Article.
- B. Contract Documents Examination Report: Within 15 days of Contractor's Notice to Proceed, submit the Contract Documents review report as specified in Part 3.
- C. Strategies and Procedures Plan: Within 30 days of Contractor's Notice to Proceed, submit TAB strategies and step-by-step procedures as specified in "Preparation" Article.

- D. Certified TAB reports.
- E. Sample report forms.
- F. Instrument calibration reports, to include the following:
 - 1. Instrument type and make.
 - 2. Serial number.
 - 3. Application.
 - 4. Dates of use.
 - 5. Dates of calibration.

1.5 QUALITY ASSURANCE

- A. TAB Contractor Qualifications: Engage a TAB entity certified by AABC, NEBB or TABB.
 - 1. TAB Field Supervisor: Employee of the TAB contractor and certified by AABC, NEBB or TABB.
 - 2. TAB Technician: Employee of the TAB contractor and who is certified by AABC, NEBB or TABB as a TAB technician.
- B. TAB Conference: Meet with Architect and Owner on approval of the TAB strategies and procedures plan to develop a mutual understanding of the details. Require the participation of the TAB field supervisor and technicians. Provide seven days' advance notice of scheduled meeting time and location.
 - 1. Agenda Items:
 - a. The Contract Documents examination report.
 - b. The TAB plan.
 - c. Coordination and cooperation of trades and subcontractors.
 - d. Coordination of documentation and communication flow.
- C. Certify TAB field data reports and perform the following:
 - 1. Review field data reports to validate accuracy of data and to prepare certified TAB reports.
 - 2. Certify that the TAB team complied with the approved TAB plan and the procedures specified and referenced in this Specification.
- D. TAB Report Forms: Use standard TAB contractor's forms approved by Architect.
- E. Instrumentation Type, Quantity, Accuracy, and Calibration: As described in ASHRAE 111, Section 5, "Instrumentation."
- F. ASHRAE Compliance: Applicable requirements in ASHRAE 62.1, Section 7.2.2 - "Air Balancing."

- G. ASHRAE/IESNA Compliance: Applicable requirements in ASHRAE/IESNA 90.1, Section 6.7.2.3 - "System Balancing."

1.6 PROJECT CONDITIONS

- A. Full Owner Occupancy: Owner will occupy the site and existing building during entire TAB period. Cooperate with Owner during TAB operations to minimize conflicts with Owner's operations.
- B. Partial Owner Occupancy: Owner may occupy completed areas of building before Substantial Completion. Cooperate with Owner during TAB operations to minimize conflicts with Owner's operations.

1.7 COORDINATION

- A. Notice: Provide seven days' advance notice for each test. Include scheduled test dates and times.
- B. Perform TAB after leakage and pressure tests on air distribution systems have been satisfactorily completed.

PART 2 - PRODUCTS (Not Applicable)

PART 3 - EXECUTION

3.1 EXAMINATION

- A. Examine the Contract Documents to become familiar with Project requirements and to discover conditions in systems' designs that may preclude proper TAB of systems and equipment.
- B. Examine systems for installed balancing devices, such as test ports, gage cocks, thermometer wells, flow-control devices, balancing valves and fittings, and manual volume dampers. Verify that locations of these balancing devices are accessible.
- C. Examine the approved submittals for HVAC systems and equipment.
- D. Examine design data including HVAC system descriptions, statements of design assumptions for environmental conditions and systems' output, and statements of philosophies and assumptions about HVAC system and equipment controls.
- E. Examine equipment performance data including fan curves.
 - 1. Relate performance data to Project conditions and requirements, including system effects that can create undesired or unpredicted conditions that cause reduced capacities in all or part of a system.

2. Calculate system-effect factors to reduce performance ratings of HVAC equipment when installed under conditions different from the conditions used to rate equipment performance. To calculate system effects for air systems, use tables and charts found in AMCA 201, "Fans and Systems," or in SMACNA's "HVAC Systems - Duct Design." Compare results with the design data and installed conditions.
- F. Examine system and equipment installations and verify that field quality-control testing, cleaning, and adjusting specified in individual Sections have been performed.
- G. Examine test reports specified in individual system and equipment Sections.
- H. Examine HVAC equipment and filters and verify that bearings are greased, belts are aligned and tight, and equipment with functioning controls is ready for operation.
- I. Examine operating safety interlocks and controls on HVAC equipment.
- J. Report deficiencies discovered before and during performance of TAB procedures. Observe and record system reactions to changes in conditions. Record default set points if different from indicated values.

3.2 PREPARATION

- A. Prepare a TAB plan that includes strategies and step-by-step procedures.
- B. Complete system-readiness checks and prepare reports. Verify the following:
 1. Permanent electrical-power wiring is complete.
 2. Automatic temperature-control systems are operational.
 3. Equipment and duct access doors are securely closed.
 4. Balance dampers are open.

3.3 GENERAL PROCEDURES FOR TESTING AND BALANCING

- A. Perform testing and balancing procedures on each system according to the procedures contained in AABC's "National Standards for Total System Balance", ASHRAE 111, NEBB's "Procedural Standards for Testing, Adjusting, and Balancing of Environmental Systems" or SMACNA's "HVAC Systems - Testing, Adjusting, and Balancing" and in this Section.
 1. Comply with requirements in ASHRAE 62.1, Section 7.2.2 - "Air Balancing."
- B. Cut insulation, ducts, and equipment cabinets for installation of test probes to the minimum extent necessary for TAB procedures.
 1. After testing and balancing, patch probe holes in ducts with same material and thickness as used to construct ducts.

2. After testing and balancing, install test ports and duct access doors that comply with requirements in Section 233300 "Air Duct Accessories."
- C. Mark equipment and balancing devices, including damper-control positions, fan-speed-control levers, and similar controls and devices, with paint or other suitable, permanent identification material to show final settings.
- D. Take and report testing and balancing measurements in inch-pound (IP) units.

3.4 GENERAL PROCEDURES FOR BALANCING AIR SYSTEMS

- A. Prepare test reports for both fans and outlets. Obtain manufacturer's outlet factors and recommended testing procedures. Crosscheck the summation of required outlet volumes with required fan volumes.
- B. Prepare schematic diagrams of systems' "as-built" duct layouts.
- C. For variable-air-volume systems, develop a plan to simulate diversity.
- D. Check airflow patterns from the outdoor-air louvers and dampers and the return- and exhaust-air dampers through the supply-fan discharge and mixing dampers.
- E. Locate start-stop and disconnect switches, electrical interlocks, and motor starters.
- F. Verify that motor starters are equipped with properly sized thermal protection.
- G. Check dampers for proper position to achieve desired airflow path.
- H. Check for airflow blockages.
- I. Check for proper sealing of air-handling-unit components.
- J. Verify that air duct system is sealed as specified in Section 233113 "Metal Ducts."

3.5 PROCEDURES FOR CONSTANT-VOLUME AIR SYSTEMS

- A. Adjust fans to deliver total indicated airflows within the maximum allowable fan speed listed by fan manufacturer.
 1. Measure total airflow.
 - a. Where sufficient space in ducts is unavailable for Pitot-tube traverse measurements, measure airflow at terminal outlets and inlets and calculate the total airflow.
 2. Measure fan static pressures as follows to determine actual static pressure:
 - a. Measure outlet static pressure as far downstream from the fan as practical and upstream from restrictions in ducts such as elbows and transitions.

- b. Measure static pressure directly at the fan outlet or through the flexible connection.
 - c. Measure inlet static pressure of single-inlet fans in the inlet duct as near the fan as possible, upstream from the flexible connection, and downstream from duct restrictions.
 - d. Measure inlet static pressure of double-inlet fans through the wall of the plenum that houses the fan.
 3. Measure static pressure across each component that makes up an air-handling unit, rooftop unit, and other air-handling and -treating equipment.
 - a. Report the cleanliness status of filters and the time static pressures are measured.
 4. Measure static pressures entering and leaving other devices, such as sound traps, heat-recovery equipment, and air washers, under final balanced conditions.
 5. Review Record Documents to determine variations in design static pressures versus actual static pressures. Calculate actual system-effect factors. Recommend adjustments to accommodate actual conditions.
 6. Obtain approval from Architect for adjustment of fan speed higher or lower than indicated speed. Comply with requirements in HVAC Sections for air-handling units for adjustment of fans, belts, and pulley sizes to achieve indicated air-handling-unit performance.
 7. Do not make fan-speed adjustments that result in motor overload. Consult equipment manufacturers about fan-speed safety factors. Modulate dampers and measure fan-motor amperage to ensure that no overload will occur. Measure amperage in full-cooling, full-heating, economizer, and any other operating mode to determine the maximum required brake horsepower.
- B. Adjust volume dampers for main duct, submain ducts, and major branch ducts to indicated airflows within specified tolerances.
 1. Measure airflow of submain and branch ducts.
 - a. Where sufficient space in submain and branch ducts is unavailable for Pitot-tube traverse measurements, measure airflow at terminal outlets and inlets and calculate the total airflow for that zone.
 2. Measure static pressure at a point downstream from the balancing damper, and adjust volume dampers until the proper static pressure is achieved.
 3. Re-measure each submain and branch duct after all have been adjusted. Continue to adjust submain and branch ducts to indicated airflows within specified tolerances.
- C. Measure air outlets and inlets without making adjustments.
 1. Measure terminal outlets using a direct-reading hood or outlet manufacturer's written instructions and calculating factors.

- D. Adjust air outlets and inlets for each space to indicated airflows within specified tolerances of indicated values. Make adjustments using branch volume dampers rather than extractors and the dampers at air terminals.
 - 1. Adjust each outlet in same room or space to within specified tolerances of indicated quantities without generating noise levels above the limitations prescribed by the Contract Documents.
 - 2. Adjust patterns of adjustable outlets for proper distribution without drafts.

3.6 PROCEDURES FOR VARIABLE-AIR-VOLUME SYSTEMS

- A. Compensating for Diversity: When the total airflow of all terminal units is more than the indicated airflow of the fan, place a selected number of terminal units at a minimum set-point airflow with the remainder at maximum-airflow condition until the total airflow of the terminal units equals the indicated airflow of the fan. Select the reduced-airflow terminal units so they are distributed evenly among the branch ducts.

3.7 PROCEDURES FOR STEAM SYSTEMS

- A. Measure and record upstream and downstream pressure of each piece of equipment.
- B. Measure and record upstream and downstream steam pressure of pressure-reducing valves.
- C. Check settings and operation of automatic temperature-control valves, self-contained control valves, and pressure-reducing valves. Record final settings.
- D. Check settings and operation of each safety valve. Record settings.
- E. Verify the operation of each steam trap.

3.8 PROCEDURES FOR TESTING, ADJUSTING, AND BALANCING EXISTING SYSTEMS

- A. Perform a preconstruction inspection of existing equipment that is to remain and be reused.
 - 1. Measure and record the operating speed, airflow, and static pressure of each fan.
 - 2. Measure motor voltage and amperage. Compare the values to motor nameplate information.
 - 3. Check the refrigerant charge.
 - 4. Check the condition of filters.
 - 5. Check the condition of coils.
 - 6. Check the operation of the drain pan and condensate-drain trap.
 - 7. Check bearings and other lubricated parts for proper lubrication.

8. Report on the operating condition of the equipment and the results of the measurements taken. Report deficiencies.
- B. Before performing testing and balancing of existing systems, inspect existing equipment that is to remain and be reused to verify that existing equipment has been cleaned and refurbished. Verify the following:
1. New filters are installed.
 2. Coils are clean and fins combed.
 3. Drain pans are clean.
 4. Fans are clean.
 5. Bearings and other parts are properly lubricated.
 6. Deficiencies noted in the preconstruction report are corrected.
- C. Perform testing and balancing of existing systems to the extent that existing systems are affected by the renovation work.
1. Compare the indicated airflow of the renovated work to the measured fan airflows, and determine the new fan speed and the face velocity of filters and coils.
 2. Verify that the indicated airflows of the renovated work result in filter and coil face velocities and fan speeds that are within the acceptable limits defined by equipment manufacturer.
 3. If calculations increase or decrease the air flow rates and water flow rates by more than 5 percent, make equipment adjustments to achieve the calculated rates. If increase or decrease is 5 percent or less, equipment adjustments are not required.
 4. Balance each air outlet.

3.9 TOLERANCES

- A. Set HVAC system's air flow rates and water flow rates within the following tolerances:
1. Supply, Return, and Exhaust Fans and Equipment with Fans: Plus or minus 10 percent.
 2. Air Outlets and Inlets: Plus or minus 10 percent.

3.10 REPORTING

- A. Initial Construction-Phase Report: Based on examination of the Contract Documents as specified in "Examination" Article, prepare a report on the adequacy of design for systems' balancing devices. Recommend changes and additions to systems' balancing devices to facilitate proper performance measuring and balancing. Recommend changes and additions to HVAC systems and general construction to allow access for performance measuring and balancing devices.
- B. Status Reports: Prepare weekly progress reports to describe completed procedures, procedures in progress, and scheduled procedures. Include a list of deficiencies and

problems found in systems being tested and balanced. Prepare a separate report for each system and each building floor for systems serving multiple floors.

3.11 FINAL REPORT

- A. General: Prepare a certified written report; tabulate and divide the report into separate sections for tested systems and balanced systems.
1. Include a certification sheet at the front of the report's binder, signed and sealed by the certified testing and balancing engineer.
 2. Include a list of instruments used for procedures, along with proof of calibration.
- B. Final Report Contents: In addition to certified field-report data, include the following:
1. Pump curves.
 2. Fan curves.
 3. Manufacturers' test data.
 4. Field test reports prepared by system and equipment installers.
 5. Other information relative to equipment performance; do not include Shop Drawings and product data.
- C. General Report Data: In addition to form titles and entries, include the following data:
1. Title page.
 2. Name and address of the TAB contractor.
 3. Project name.
 4. Project location.
 5. Architect's name and address.
 6. Engineer's name and address.
 7. Contractor's name and address.
 8. Report date.
 9. Signature of TAB supervisor who certifies the report.
 10. Table of Contents with the total number of pages defined for each section of the report. Number each page in the report.
 11. Summary of contents including the following:
 - a. Indicated versus final performance.
 - b. Notable characteristics of systems.
 - c. Description of system operation sequence if it varies from the Contract Documents.
 12. Nomenclature sheets for each item of equipment.
 13. Data for terminal units, including manufacturer's name, type, size, and fittings.
 14. Notes to explain why certain final data in the body of reports vary from indicated values.
 15. Test conditions for fans and pump performance forms including the following:
 - a. Settings for exhaust-air dampers.

- b. Fan drive settings including settings and percentage of maximum pitch diameter.
 - c. Other system operating conditions that affect performance.
- D. System Diagrams: Include schematic layouts of air and hydronic distribution systems. Present each system with single-line diagram and include the following:
 1. Quantities of exhaust airflows.
 2. Position of balancing devices.
- E. Fan Test Reports: For supply, return, and exhaust fans, include the following:
 1. Fan Data:
 - a. System identification.
 - b. Location.
 - c. Make and type.
 - d. Model number and size.
 - e. Manufacturer's serial number.
 - f. Arrangement and class.
 - g. Sheave make, size in inches, and bore.
 - h. Center-to-center dimensions of sheave, and amount of adjustments in inches.
 2. Motor Data:
 - a. Motor make, and frame type and size.
 - b. Horsepower and rpm.
 - c. Volts, phase, and hertz.
 - d. Full-load amperage and service factor.
 - e. Sheave make, size in inches, and bore.
 - f. Center-to-center dimensions of sheave, and amount of adjustments in inches.
 - g. Number, make, and size of belts.
 3. Test Data (Indicated and Actual Values):
- F. Air-Terminal-Device Reports:
 1. Unit Data:
 - a. System and air-handling unit identification.
 - b. Location and zone.
 - c. Apparatus used for test.
 - d. Area served.
 - e. Make.
 - f. Number from system diagram.
 - g. Type and model number.
 - h. Size.
 - i. Effective area in sq. ft..

2. Test Data (Indicated and Actual Values):

- a. Air flow rate in cfm.
- b. Air velocity in fpm.
- c. Preliminary air flow rate as needed in cfm.
- d. Preliminary velocity as needed in fpm.
- e. Final air flow rate in cfm.
- f. Final velocity in fpm.

G. Instrument Calibration Reports:

1. Report Data:

- a. Instrument type and make.
- b. Serial number.
- c. Application.
- d. Dates of use.
- e. Dates of calibration.

3.12 INSPECTIONS

A. Initial Inspection:

1. After testing and balancing are complete, operate each system and randomly check measurements to verify that the system is operating according to the final test and balance readings documented in the final report.
2. Check the following for each system:
 - a. Measure airflow of at least 10 percent of air outlets.
 - b. Verify that balancing devices are marked with final balance position.
 - c. Note deviations from the Contract Documents in the final report.

B. Final Inspection:

1. After initial inspection is complete and documentation by random checks verifies that testing and balancing are complete and accurately documented in the final report, request that a final inspection be made by Architect.
2. The TAB contractor's test and balance engineer shall conduct the inspection in the presence of Architect and Owner.

C. TAB Work will be considered defective if it does not pass final inspections. If TAB Work fails, proceed as follows:

1. Recheck all measurements and make adjustments. Revise the final report and balancing device settings to include all changes; resubmit the final report and request a second final inspection.
2. If the second final inspection also fails, Owner may contract the services of another TAB contractor to complete TAB Work according to the Contract

Documents and deduct the cost of the services from the original TAB contractor's final payment.

- D. Prepare test and inspection reports.

3.13 ADDITIONAL TESTS

- A. Within 90 days of completing TAB, perform additional TAB to verify that balanced conditions are being maintained throughout and to correct unusual conditions.
- B. Seasonal Periods: If initial TAB procedures were not performed during near-peak summer and winter conditions, perform additional TAB during near-peak summer and winter conditions.

END OF SECTION 230593

SECTION 230713

DUCT INSULATION

PART 1 - GENERAL

1.1 RELATED DOCUMENTS

- A. Drawings and general provisions of the Contract, including General and Supplementary Conditions and Division 01 Specification Sections, apply to this Section.

1.2 SUMMARY

- A. Section includes insulating the following duct services:
 - 1. Indoor, exposed exhaust between equipment and penetration of building exterior and where indicated.
- B. Related Sections:
 - 1. Section 230716 "HVAC Equipment Insulation."
 - 2. Section 230719 "HVAC Piping Insulation."

1.3 ACTION SUBMITTALS

- A. Product Data: For each type of product indicated. Include thermal conductivity, water-vapor permeance thickness, and jackets (both factory- and field-applied if any).
- B. Shop Drawings: Include plans, elevations, sections, details, and attachments to other work.
 - 1. Detail application of protective shields, saddles, and inserts at hangers for each type of insulation and hanger.
 - 2. Detail insulation application at elbows, fittings, dampers, specialties and flanges for each type of insulation.
 - 3. Detail application of field-applied jackets.
 - 4. Detail application at linkages of control devices.

1.4 INFORMATIONAL SUBMITTALS

- A. Qualification Data: For qualified Installer.

- B. Material Test Reports: From a qualified testing agency acceptable to authorities having jurisdiction indicating, interpreting, and certifying test results for compliance of insulation materials, sealers, attachments, cements, and jackets, with requirements indicated. Include dates of tests and test methods employed.
- C. Field quality-control reports.

1.5 QUALITY ASSURANCE

- A. Installer Qualifications: Skilled mechanics who have successfully completed an apprenticeship program or another craft training program certified by the Department of Labor, Bureau of Apprenticeship and Training.
- B. Surface-Burning Characteristics: For insulation and related materials, as determined by testing identical products according to ASTM E 84, by a testing agency acceptable to authorities having jurisdiction. Factory label insulation and jacket materials and adhesive, mastic, tapes, and cement material containers, with appropriate markings of applicable testing agency.
 - 1. Insulation Installed Indoors: Flame-spread index of 25 or less, and smoke-developed index of 50 or less.

1.6 DELIVERY, STORAGE, AND HANDLING

- A. Packaging: Insulation material containers shall be marked by manufacturer with appropriate ASTM standard designation, type and grade, and maximum use temperature.

1.7 COORDINATION

- A. Coordinate sizes and locations of supports, hangers, and insulation shields specified in Section 230529 "Hangers and Supports for HVAC Piping and Equipment."
- B. Coordinate clearance requirements with duct Installer for duct insulation application. Before preparing ductwork Shop Drawings, establish and maintain clearance requirements for installation of insulation and field-applied jackets and finishes and for space required for maintenance.
- C. Coordinate installation and testing of heat tracing.

1.8 SCHEDULING

- A. Schedule insulation application after pressure testing systems and, where required, after installing and testing heat tracing. Insulation application may begin on segments that have satisfactory test results.

- B. Complete installation and concealment of plastic materials as rapidly as possible in each area of construction.

PART 2 - PRODUCTS

2.1 INSULATION MATERIALS

- A. Comply with requirements in "Duct Insulation Schedule, General," "Indoor Duct and Plenum Insulation Schedule," articles for where insulating materials shall be applied.
- B. Products shall not contain asbestos, lead, mercury, or mercury compounds.
- C. Products that come in contact with stainless steel shall have a leachable chloride content of less than 50 ppm when tested according to ASTM C 871.
- D. Mineral-Fiber Board Insulation: Mineral or glass fibers bonded with a thermosetting resin. Comply with ASTM C 612, Type IA or Type IB. For duct and plenum applications, provide insulation with factory-applied FSK jacket. Factory-applied jacket requirements are specified in "Factory-Applied Jackets" Article.
 - 1. Manufacturers: Subject to compliance with requirements, available manufacturers offering products that may be incorporated into the Work include, but are not limited to the following:
 - a. CertainTeed Corporation.
 - b. Johns Manville; a Berkshire Hathaway company.
 - c. Knauf Insulation.
 - d. Manson Insulation Inc.
 - e. Owens Corning.

2.2 ADHESIVES

- A. Materials shall be compatible with insulation materials, jackets, and substrates and for bonding insulation to itself and to surfaces to be insulated unless otherwise indicated.
- B. Mineral-Fiber Adhesive: Comply with MIL-A-3316C, Class 2, Grade A.
 - 1. Manufacturers: Subject to compliance with requirements, available manufacturers offering products that may be incorporated into the Work include, but are not limited to the following:
 - a. Childers Brand; H. B. Fuller Construction Products.
 - b. Eagle Bridges - Marathon Industries.
 - c. Foster Brand; H. B. Fuller Construction Products.
 - d. Mon-Eco Industries, Inc.

- C. FSK Jacket Adhesive: Comply with MIL-A-3316C, Class 2, Grade A for bonding insulation jacket lap seams and joints.
 - 1. Manufacturers: Subject to compliance with requirements, available manufacturers offering products that may be incorporated into the Work include, but are not limited to the following:
 - a. Childers Brand; H. B. Fuller Construction Products.
 - b. Eagle Bridges - Marathon Industries.
 - c. Foster Brand; H. B. Fuller Construction Products.
 - d. Mon-Eco Industries, Inc.

2.3 MASTICS

- A. Materials shall be compatible with insulation materials, jackets, and substrates; comply with MIL-PRF-19565C, Type II.
- B. Breather Mastic: Water based; suitable for indoor and outdoor use on above ambient services.
 - 1. Manufacturers: Subject to compliance with requirements, available manufacturers offering products that may be incorporated into the Work include, but are not limited to the following:
 - a. Childers Brand; H. B. Fuller Construction Products.
 - b. Eagle Bridges - Marathon Industries.
 - c. Foster Brand; H. B. Fuller Construction Products.
 - d. Knauf Insulation.
 - e. Mon-Eco Industries, Inc.
 - f. Vimasco Corporation.
 - 2. Water-Vapor Permeance: ASTM F 1249, 1.8 perms (1.2 metric perms) at 0.0625-inch (1.6-mm) dry film thickness.
 - 3. Service Temperature Range: Minus 20 to plus 180 deg F (Minus 29 to plus 82 deg C).
 - 4. Solids Content: 60 percent by volume and 66 percent by weight.
 - 5. Color: White.

2.4 SEALANTS

- A. FSK and Metal Jacket Flashing Sealants:
 - 1. Manufacturers: Subject to compliance with requirements, available manufacturers offering products that may be incorporated into the Work include, but are not limited to the following:
 - a. Childers Brand; H. B. Fuller Construction Products.

- b. Eagle Bridges - Marathon Industries.
 - c. Foster Brand; H. B. Fuller Construction Products.
 - d. Mon-Eco Industries, Inc.
2. Materials shall be compatible with insulation materials, jackets, and substrates.
 3. Fire- and water-resistant, flexible, elastomeric sealant.
 4. Service Temperature Range: Minus 40 to plus 250 deg F (Minus 40 to plus 121 deg C).
 5. Color: Aluminum.

2.5 TAPES

A. FSK Tape: Foil-face, vapor-retarder tape matching factory-applied jacket with acrylic adhesive; complying with ASTM C 1136.

1. Manufacturers: Subject to compliance with requirements, available manufacturers offering products that may be incorporated into the Work include, but are not limited to the following:
 - a. Avery Dennison Corporation, Specialty Tapes Division.
 - b. Compac Corporation.
 - c. Ideal Tape Co., Inc., an American Biltrite Company.
 - d. Knauf Insulation.
 - e. Venture Tape.
2. Width: 3 inches (75 mm).
3. Thickness: 6.5 mils (0.16 mm).
4. Adhesion: 90 ounces force/inch (1.0 N/mm) in width.
5. Elongation: 2 percent.
6. Tensile Strength: 40 lbf/inch (7.2 N/mm) in width.
7. FSK Tape Disks and Squares: Precut disks or squares of FSK tape.

B. Aluminum-Foil Tape: Vapor-retarder tape with acrylic adhesive.

1. Manufacturers: Subject to compliance with requirements, available manufacturers offering products that may be incorporated into the Work include, but are not limited to the following:
 - a. Avery Dennison Corporation, Specialty Tapes Division.
 - b. Compac Corporation.
 - c. Ideal Tape Co., Inc., an American Biltrite Company.
 - d. Knauf Insulation.
 - e. Venture Tape.
2. Width: 2 inches (50 mm).
3. Thickness: 3.7 mils (0.093 mm).

4. Adhesion: 100 ounces force/inch (1.1 N/mm) in width.
5. Elongation: 5 percent.
6. Tensile Strength: 34 lbf/inch (6.2 N/mm) in width.

2.6 SECUREMENTS

A. Bands:

1. Manufacturers: Subject to compliance with requirements, available manufacturers offering products that may be incorporated into the Work include, but are not limited to the following:
 - a. ITW Insulation Systems; Illinois Tool Works, Inc.
 - b. RPR Products, Inc.
2. Stainless Steel: ASTM A 167 or ASTM A 240/A 240M, Type 304 or Type 316; 0.015 inch (0.38 mm) thick, 3/4 inch (19 mm) wide with wing seal or closed seal.
3. Aluminum: ASTM B 209 (ASTM B 209M), Alloy 3003, 3005, 3105, or 5005; Temper H-14, 0.020 inch (0.51 mm) thick, 3/4 inch (19 mm) wide with wing seal or closed seal.

B. Insulation Pins and Hangers:

1. Capacitor-Discharge-Weld Pins: Copper- or zinc-coated steel pin, fully annealed for capacitor-discharge welding, 0.135-inch- (3.5-mm-) diameter shank, length to suit depth of insulation indicated.
 - a. Manufacturers: Subject to compliance with requirements, available manufacturers offering products that may be incorporated into the Work include, but are not limited to the following:
 - 1) AGM Industries, Inc.
 - 2) Gemco.
 - 3) Hardcast, Inc.
 - 4) Midwest Fasteners, Inc.
 - 5) Nelson Stud Welding.
2. Cupped-Head, Capacitor-Discharge-Weld Pins: Copper- or zinc-coated steel pin, fully annealed for capacitor-discharge welding, 0.135-inch- (3.5-mm-) diameter shank, length to suit depth of insulation indicated with integral 1-1/2-inch (38-mm) galvanized carbon-steel washer.
 - a. Manufacturers: Subject to compliance with requirements, available manufacturers offering products that may be incorporated into the Work include, but are not limited to the following:
 - 1) AGM Industries, Inc.
 - 2) CL WARD & Family Inc.
 - 3) Gemco.

- 4) Hardcast, Inc.
 - 5) Midwest Fasteners, Inc.
 - 6) Nelson Stud Welding.
3. Metal, Adhesively Attached, Perforated-Base Insulation Hangers: Baseplate welded to projecting spindle that is capable of holding insulation, of thickness indicated, securely in position indicated when self-locking washer is in place. Comply with the following requirements:
- a. Manufacturers: Subject to compliance with requirements, available manufacturers offering products that may be incorporated into the Work include, but are not limited to the following:
 - 1) AGM Industries, Inc.
 - 2) Gemco.
 - 3) Midwest Fasteners, Inc.
 - b. Baseplate: Perforated, galvanized carbon-steel sheet, 0.030 inch (0.76 mm) thick by 2 inches (50 mm) square.
 - c. Spindle: Stainless steel, fully annealed, 0.106-inch- (2.6-mm-) diameter shank, length to suit depth of insulation indicated.
 - d. Adhesive: Recommended by hanger manufacturer. Product with demonstrated capability to bond insulation hanger securely to substrates indicated without damaging insulation, hangers, and substrates.
4. Nonmetal, Adhesively Attached, Perforated-Base Insulation Hangers: Baseplate fastened to projecting spindle that is capable of holding insulation, of thickness indicated, securely in position indicated when self-locking washer is in place. Comply with the following requirements:
- a. Manufacturers: Subject to compliance with requirements, available manufacturers offering products that may be incorporated into the Work include, but are not limited to the following:
 - 1) Gemco.
 - 2) Midwest Fasteners, Inc.
 - b. Baseplate: Perforated, nylon sheet, 0.030 inch (0.76 mm) thick by 1-1/2 inches (38 mm) in diameter.
 - c. Spindle: Nylon, 0.106-inch- (2.6-mm-) diameter shank, length to suit depth of insulation indicated, up to 2-1/2 inches (63 mm).
 - d. Adhesive: Recommended by hanger manufacturer. Product with demonstrated capability to bond insulation hanger securely to substrates indicated without damaging insulation, hangers, and substrates.
5. Insulation-Retaining Washers: Self-locking washers formed from 0.016-inch- (0.41-mm-) thick, stainless-steel sheet, with beveled edge sized as required to

hold insulation securely in place but not less than 1-1/2 inches (38 mm) in diameter.

a. Manufacturers: Subject to compliance with requirements, available manufacturers offering products that may be incorporated into the Work include, but are not limited to the following:

- 1) AGM Industries, Inc.
- 2) Gemco.
- 3) Hardcast, Inc.
- 4) Midwest Fasteners, Inc.
- 5) Nelson Stud Welding.

b. Protect ends with capped self-locking washers incorporating a spring steel insert to ensure permanent retention of cap in exposed locations.

6. Nonmetal Insulation-Retaining Washers: Self-locking washers formed from 0.016-inch- (0.41-mm-) thick nylon sheet, with beveled edge sized as required to hold insulation securely in place but not less than 1-1/2 inches (38 mm) in diameter.

a. Manufacturers: Subject to compliance with requirements, available manufacturers offering products that may be incorporated into the Work include, but are not limited to the following:

- 1) Gemco.
- 2) Midwest Fasteners, Inc.

2.7 CORNER ANGLES

A. Aluminum Corner Angles: 0.040 inch (1.0 mm) thick, minimum 1 by 1 inch (25 by 25 mm), aluminum according to ASTM B 209 (ASTM B 209M), Alloy 3003, 3005, 3105, or 5005; Temper H-14.

B. Stainless-Steel Corner Angles: 0.024 inch (0.61 mm) thick, minimum 1 by 1 inch (25 by 25 mm), stainless steel according to ASTM A 167 or ASTM A 240/A 240M, Type 304 or Type 316.

PART 3 - EXECUTION

3.1 EXAMINATION

A. Examine substrates and conditions for compliance with requirements for installation tolerances and other conditions affecting performance of insulation application.

1. Verify that systems to be insulated have been tested and are free of defects.
2. Verify that surfaces to be insulated are clean and dry.

- B. Proceed with installation only after unsatisfactory conditions have been corrected.

3.2 PREPARATION

- A. Surface Preparation: Clean and dry surfaces to receive insulation. Remove materials that will adversely affect insulation application.

3.3 GENERAL INSTALLATION REQUIREMENTS

- A. Install insulation materials, accessories, and finishes with smooth, straight, and even surfaces; free of voids throughout the length of ducts and fittings.
- B. Install insulation materials, vapor barriers or retarders, jackets, and thicknesses required for each item of duct system as specified in insulation system schedules.
- C. Install accessories compatible with insulation materials and suitable for the service. Install accessories that do not corrode, soften, or otherwise attack insulation or jacket in either wet or dry state.
- D. Install insulation with longitudinal seams at top and bottom of horizontal runs.
- E. Install multiple layers of insulation with longitudinal and end seams staggered.
- F. Keep insulation materials dry during application and finishing.
- G. Install insulation with tight longitudinal seams and end joints. Bond seams and joints with adhesive recommended by insulation material manufacturer.
- H. Install insulation with least number of joints practical.
- I. Where vapor barrier is indicated, seal joints, seams, and penetrations in insulation at hangers, supports, anchors, and other projections with vapor-barrier mastic.
 - 1. Install insulation continuously through hangers and around anchor attachments.
 - 2. For insulation application where vapor barriers are indicated, extend insulation on anchor legs from point of attachment to supported item to point of attachment to structure. Taper and seal ends at attachment to structure with vapor-barrier mastic.
 - 3. Install insert materials and install insulation to tightly join the insert. Seal insulation to insulation inserts with adhesive or sealing compound recommended by insulation material manufacturer.
- J. Apply adhesives, mastics, and sealants at manufacturer's recommended coverage rate and wet and dry film thicknesses.
- K. Install insulation with factory-applied jackets as follows:
 - 1. Draw jacket tight and smooth.

2. Cover circumferential joints with 3-inch- (75-mm-) wide strips, of same material as insulation jacket. Secure strips with adhesive and outward clinching staples along both edges of strip, spaced 4 inches (100 mm) o.c.
 3. Overlap jacket longitudinal seams at least 1-1/2 inches (38 mm). Clean and dry surface to receive self-sealing lap. Staple laps with outward clinching staples along edge at 2 inches (50 mm) o.c.
 - a. For below ambient services, apply vapor-barrier mastic over staples.
 4. Cover joints and seams with tape, according to insulation material manufacturer's written instructions, to maintain vapor seal.
 5. Where vapor barriers are indicated, apply vapor-barrier mastic on seams and joints and at ends adjacent to duct flanges and fittings.
- L. Cut insulation in a manner to avoid compressing insulation more than 75 percent of its nominal thickness.
- M. Finish installation with systems at operating conditions. Repair joint separations and cracking due to thermal movement.
- N. Repair damaged insulation facings by applying same facing material over damaged areas. Extend patches at least 4 inches (100 mm) beyond damaged areas. Adhere, staple, and seal patches similar to butt joints.

3.4 PENETRATIONS

- A. Insulation Installation at Roof Penetrations: Install insulation continuously through roof penetrations.
1. Seal penetrations with flashing sealant.
 2. For applications requiring only indoor insulation, terminate insulation above roof surface and seal with joint sealant. For applications requiring indoor and outdoor insulation, install insulation for outdoor applications tightly joined to indoor insulation ends. Seal joint with joint sealant.
 3. Extend jacket of outdoor insulation outside roof flashing at least **2 inches (50 mm)** below top of roof flashing.
 4. Seal jacket to roof flashing with flashing sealant.
- B. Insulation Installation at Aboveground Exterior Wall Penetrations: Install insulation continuously through wall penetrations.
1. Seal penetrations with flashing sealant.
 2. For applications requiring only indoor insulation, terminate insulation inside wall surface and seal with joint sealant. For applications requiring indoor and outdoor insulation, install insulation for outdoor applications tightly joined to indoor insulation ends. Seal joint with joint sealant.
 3. Extend jacket of outdoor insulation outside wall flashing and overlap wall flashing at least 2 inches (50 mm).
 4. Seal jacket to wall flashing with flashing sealant.

- C. Insulation Installation at Interior Wall and Partition Penetrations (That Are Not Fire Rated): Install insulation continuously through walls and partitions.
- D. Insulation Installation at Fire-Rated Wall and Partition Penetrations: Terminate insulation at fire damper sleeves for fire-rated wall and partition penetrations. Externally insulate damper sleeves to match adjacent insulation and overlap duct insulation at least 2 inches (50 mm).
 - 1. Comply with requirements in Section 078413 "Penetration Firestopping."
- E. Insulation Installation at Floor Penetrations:
 - 1. Duct: For penetrations through fire-rated assemblies, terminate insulation at fire damper sleeves and externally insulate damper sleeve beyond floor to match adjacent duct insulation. Overlap damper sleeve and duct insulation at least 2 inches (50 mm).
 - 2. Seal penetrations through fire-rated assemblies. Comply with requirements in Section 078413 "Penetration Firestopping."

3.5 INSTALLATION OF MINERAL-FIBER INSULATION

- A. Board Insulation Installation on Ducts and Plenums: Secure with adhesive and insulation pins.
 - 1. Apply adhesives according to manufacturer's recommended coverage rates per unit area, for 100 percent coverage of duct and plenum surfaces.
 - 2. Apply adhesive to entire circumference of ducts and to all surfaces of fittings and transitions.
 - 3. Install either capacitor-discharge-weld pins and speed washers or cupped-head, capacitor-discharge-weld pins on sides and bottom of horizontal ducts and sides of vertical ducts as follows:
 - a. On duct sides with dimensions 18 inches (450 mm) and smaller, place pins along longitudinal centerline of duct. Space 3 inches (75 mm) maximum from insulation end joints, and 16 inches (400 mm) o.c.
 - b. On duct sides with dimensions larger than 18 inches (450 mm), space pins 16 inches (400 mm) o.c. each way, and 3 inches (75 mm) maximum from insulation joints. Install additional pins to hold insulation tightly against surface at cross bracing.
 - c. Pins may be omitted from top surface of horizontal, rectangular ducts and plenums.
 - d. Do not overcompress insulation during installation.
 - e. Cut excess portion of pins extending beyond speed washers or bend parallel with insulation surface. Cover exposed pins and washers with tape matching insulation facing.
 - 4. Install insulation on rectangular duct elbows and transitions with a full insulation section for each surface. Groove and score insulation to fit as closely as possible

to outside and inside radius of elbows. Install insulation on round and flat-oval duct elbows with individually mitered gores cut to fit the elbow.

5. Insulate duct stiffeners, hangers, and flanges that protrude beyond insulation surface with 6-inch- (150-mm-) wide strips of same material used to insulate duct. Secure on alternating sides of stiffener, hanger, and flange with pins spaced 6 inches (150 mm) o.c.

3.6 FIELD QUALITY CONTROL

- A. Testing Agency: Engage a qualified testing agency to perform tests and inspections.
- B. Perform tests and inspections.
- C. Tests and Inspections:
 1. Inspect ductwork, randomly selected by Architect, by removing field-applied jacket and insulation in layers in reverse order of their installation. Extent of inspection shall be limited to one location for each duct system defined in the "Duct Insulation Schedule, General" Article.
- D. All insulation applications will be considered defective Work if sample inspection reveals noncompliance with requirements.

3.7 DUCT INSULATION SCHEDULE, GENERAL

- A. Plenums and Ducts Requiring Insulation:
 1. Indoor, exposed exhaust between equipment and penetration of building exterior and where indicated.
- B. Items Not Insulated:
 1. Fibrous-glass ducts.
 2. Metal ducts with duct liner of sufficient thickness to comply with energy code and ASHRAE/IESNA 90.1.
 3. Factory-insulated flexible ducts.
 4. Factory-insulated plenums and casings.
 5. Flexible connectors.
 6. Vibration-control devices.
 7. Factory-insulated access panels and doors.

3.8 INDOOR DUCT AND PLENUM INSULATION SCHEDULE

- A. Exposed, rectangular and round, exhaust-air duct insulation shall be the following:
 1. Mineral-Fiber Board: 2 inches (50 mm) thick and 3-lb/cu. ft. (48-kg/cu. m) nominal density.

END OF SECTION 230713

SECTION 230716

HVAC EQUIPMENT INSULATION

PART 1 - GENERAL

1.1 RELATED DOCUMENTS

- A. Drawings and general provisions of the Contract, including General and Supplementary Conditions and Division 01 Specification Sections, apply to this Section.

1.2 SUMMARY

- A. Section includes insulating the following HVAC equipment that is not factory insulated:
 - 1. Steam condensate pumps.
 - 2. Steam condensate tanks.
 - 3. Steam flash tanks, flash separators, moisture separators, and blow-off tanks.
- B. Related Sections:
 - 1. Section 230719 "HVAC Piping Insulation."

1.3 ACTION SUBMITTALS

- A. Product Data: For each type of product indicated. Include thermal conductivity, water-vapor permeance thickness, and jackets (both factory- and field-applied if any).

1.4 INFORMATIONAL SUBMITTALS

- A. Qualification Data: For qualified Installer.
- B. Material Test Reports: From a qualified testing agency acceptable to authorities having jurisdiction indicating, interpreting, and certifying test results for compliance of insulation materials, sealers, attachments, cements, and jackets, with requirements indicated. Include dates of tests and test methods employed.
- C. Field quality-control reports.

1.5 QUALITY ASSURANCE

- A. Installer Qualifications: Skilled mechanics who have successfully completed an apprenticeship program or another craft training program certified by the Department of Labor, Bureau of Apprenticeship and Training.

- B. Surface-Burning Characteristics: For insulation and related materials, as determined by testing identical products according to ASTM E 84, by a testing agency acceptable to authorities having jurisdiction. Factory label insulation and jacket materials and adhesive, mastic, tapes, and cement material containers, with appropriate markings of applicable testing agency.
 - 1. Insulation Installed Indoors: Flame-spread index of 25 or less, and smoke-developed index of 50 or less.
 - 2. Insulation Installed Outdoors: Flame-spread index of 75 or less, and smoke-developed index of 150 or less.

1.6 DELIVERY, STORAGE, AND HANDLING

- A. Packaging: Insulation material containers shall be marked by manufacturer with appropriate ASTM standard designation, type and grade, and maximum use temperature.

1.7 COORDINATION

- A. Coordinate sizes and locations of supports, hangers, and insulation shields specified in Section 230529 "Hangers and Supports for HVAC Piping and Equipment."
- B. Coordinate clearance requirements with equipment Installer for equipment insulation application.
- C. Coordinate installation and testing of heat tracing.

1.8 SCHEDULING

- A. Schedule insulation application after pressure testing systems and, where required, after installing and testing heat tracing. Insulation application may begin on segments that have satisfactory test results.
- B. Complete installation and concealment of plastic materials as rapidly as possible in each area of construction.

PART 2 - PRODUCTS

2.1 INSULATION MATERIALS

- A. Products shall not contain asbestos, lead, mercury, or mercury compounds.
- B. Products that come in contact with stainless steel shall have a leachable chloride content of less than 50 ppm when tested according to ASTM C 871.

- C. Insulation materials for use on austenitic stainless steel shall be qualified as acceptable according to ASTM C 795.
- D. Foam insulation materials shall not use CFC or HCFC blowing agents in the manufacturing process.
- E. Mineral-Fiber Board Insulation: Mineral or glass fibers bonded with a thermosetting resin. Comply with ASTM C 612, Type IA or Type IB. Provide insulation with factory-applied ASJ. Factory-applied jacket requirements are specified in "Factory-Applied Jackets" Article.
 - 1. Products: Subject to compliance with requirements, available products that may be incorporated into the Work include, but are not limited to, the following:
 - a. CertainTeed Corp.; CertaPro Commercial Board.
 - b. Fibrex Insulations Inc.; FBX.
 - c. Johns Manville; 800 Series Spin-Glas.
 - d. Knauf Insulation; Insulation Board.
 - e. Manson Insulation Inc.; AK Board.
 - f. Owens Corning; Fiberglas 700 Series.
- F. Mineral-Fiber, Preformed Pipe Insulation:
 - 1. Products: Subject to compliance with requirements, available products that may be incorporated into the Work include, but are not limited to, the following:
 - a. Fibrex Insulations Inc.; Coreplus 1200.
 - b. Johns Manville; Micro-Lok.
 - c. Knauf Insulation; 1000-Degree Pipe Insulation.
 - d. Manson Insulation Inc.; Alley-K.
 - e. Owens Corning; Fiberglas Pipe Insulation.
 - 2. Type I, 850 Deg F Materials: Mineral or glass fibers bonded with a thermosetting resin. Comply with ASTM C 547, Type I, Grade A, with factory-applied ASJ. Factory-applied jacket requirements are specified in "Factory-Applied Jackets" Article.
- G. Mineral-Fiber, Pipe and Tank Insulation: Mineral or glass fibers bonded with a thermosetting resin. Semi-rigid board material with factory-applied ASJ complying with ASTM C 1393, Type II or Type IIIA Category 2, or with properties similar to ASTM C 612, Type IB. Nominal density is 2.5 lb/cu. ft. or more. Thermal conductivity (k-value) at 100 deg F is 0.29 Btu x in./h x sq. ft. x deg F or less. Factory-applied jacket requirements are specified in "Factory-Applied Jackets" Article.
 - 1. Products: Subject to compliance with requirements, available products that may be incorporated into the Work include, but are not limited to, the following:
 - a. CertainTeed Corp.; CrimpWrap.
 - b. Johns Manville; MicroFlex.
 - c. Knauf Insulation; Pipe and Tank Insulation.

- d. Manson Insulation Inc.; AK Flex.
- e. Owens Corning; Fiberglas Pipe and Tank Insulation.

2.2 INSULATING CEMENTS

- A. Mineral-Fiber Insulating Cement: Comply with ASTM C 195.
 - 1. Products: Subject to compliance with requirements, available products that may be incorporated into the Work include, but are not limited to, the following:
 - a. Ramco Insulation, Inc.; Super-Stik.
- B. Mineral-Fiber, Hydraulic-Setting Insulating and Finishing Cement: Comply with ASTM C 449.
 - 1. Products: Subject to compliance with requirements, available products that may be incorporated into the Work include, but are not limited to, the following:
 - a. Ramco Insulation, Inc.; Ramcote 1200 and Quik-Cote.

2.3 ADHESIVES

- A. Materials shall be compatible with insulation materials, jackets, and substrates and for bonding insulation to itself and to surfaces to be insulated unless otherwise indicated.
- B. Mineral-Fiber Adhesive: Comply with MIL-A-3316C, Class 2, Grade A.
 - 1. Products: Subject to compliance with requirements, available products that may be incorporated into the Work include, but are not limited to, the following:
 - a. Childers Brand, Specialty Construction Brands, Inc., a business of H. B. Fuller Company; CP-127.
 - b. - Marathon Industries; 225.
 - c. Foster Brand, Specialty Construction Brands, Inc., a business of H. B. Fuller Company; 85-60/85-70.
 - d. Mon-Eco Industries, Inc.; 22-25.
 - 2. For indoor applications, adhesive shall have a VOC content of 80 g/L or less when calculated according to 40 CFR 59, Subpart D (EPA Method 24).
 - 3. Adhesive shall comply with the testing and product requirements of the California Department of Health Services' "Standard Practice for the Testing of Volatile Organic Emissions from Various Sources Using Small-Scale Environmental Chambers."
- C. ASJ Adhesive: Comply with MIL-A-3316C, Class 2, Grade A for bonding insulation jacket lap seams and joints.

1. Products: Subject to compliance with requirements, available products that may be incorporated into the Work include, but are not limited to, the following:
 - a. Childers Brand, Specialty Construction Brands, Inc., a business of H. B. Fuller Company; CP-82.
 - b. - Marathon Industries; 225.
 - c. Foster Brand, Specialty Construction Brands, Inc., a business of H. B. Fuller Company; 85-50.
 - d. Mon-Eco Industries, Inc.; 22-25.
2. For indoor applications, adhesive shall have a VOC content of 50 g/L or less when calculated according to 40 CFR 59, Subpart D (EPA Method 24).
3. Adhesive shall comply with the testing and product requirements of the California Department of Health Services' "Standard Practice for the Testing of Volatile Organic Emissions from Various Sources Using Small-Scale Environmental Chambers."

2.4 MASTICS

- A. Materials shall be compatible with insulation materials, jackets, and substrates; comply with MIL-PRF-19565C, Type II.
 1. For indoor applications, use mastics that have a VOC content of 50 g/L or less when calculated according to 40 CFR 59, Subpart D (EPA Method 24).
- B. Breather Mastic: Water based; suitable for indoor and outdoor use on above ambient services.
 1. Products: Subject to compliance with requirements, available products that may be incorporated into the Work include, but are not limited to, the following:
 - a. Childers Brand, Specialty Construction Brands, Inc., a business of H. B. Fuller Company; CP-10.
 - b. - Marathon Industries; 550.
 - c. Foster Brand, Specialty Construction Brands, Inc., a business of H. B. Fuller Company; 46-50.
 - d. Mon-Eco Industries, Inc.; 55-50.
 - e. Vimasco Corporation; WC-1/WC-5.
 2. Water-Vapor Permeance: ASTM F 1249, 1.8 perms at 0.0625-inch dry film thickness.
 3. Service Temperature Range: Minus 20 to plus 180 deg F.
 4. Solids Content: 60 percent by volume and 66 percent by weight.
 5. Color: White.

2.5 SEALANTS

- A. Joint Sealants:

B. ASJ Flashing Sealants Sealants:

1. Products: Subject to compliance with requirements, available products that may be incorporated into the Work include, but are not limited to, the following:
 - a. Childers Brand, Specialty Construction Brands, Inc., a business of H. B. Fuller Company; CP-76.
2. Materials shall be compatible with insulation materials, jackets, and substrates.
3. Fire- and water-resistant, flexible, elastomeric sealant.
4. Service Temperature Range: Minus 40 to plus 250 deg F.
5. Color: White.
6. For indoor applications, sealants shall have a VOC content of 420 g/L or less when calculated according to 40 CFR 59, Subpart D (EPA Method 24).
7. Sealants shall comply with the testing and product requirements of the California Department of Health Services' "Standard Practice for the Testing of Volatile Organic Emissions from Various Sources Using Small-Scale Environmental Chambers."

2.6 FACTORY-APPLIED JACKETS

- A. Insulation system schedules indicate factory-applied jackets on various applications. When factory-applied jackets are indicated, comply with the following:
1. ASJ: White, kraft-paper, fiberglass-reinforced scrim with aluminum-foil backing; complying with ASTM C 1136, Type I.

2.7 TAPES

- A. ASJ Tape: White vapor-retarder tape matching factory-applied jacket with acrylic adhesive, complying with ASTM C 1136.
1. Products: Subject to compliance with requirements, available products that may be incorporated into the Work include, but are not limited to, the following:
 - a. ABI, Ideal Tape Division; 428 AWF ASJ.
 - b. Avery Dennison Corporation, Specialty Tapes Division; Fasson 0836.
 - c. Compac Corporation; 104 and 105.
 - d. Venture Tape; 1540 CW Plus, 1542 CW Plus, and 1542 CW Plus/SQ.
 2. Width: 3 inches.
 3. Thickness: 11.5 mils.
 4. Adhesion: 90 ounces force/inch in width.
 5. Elongation: 2 percent.
 6. Tensile Strength: 40 lbf/inch in width.
 7. ASJ Tape Disks and Squares: Precut disks or squares of ASJ tape.

2.8 SECUREMENTS

A. Bands:

1. Products: Subject to compliance with requirements, available products that may be incorporated into the Work include, but are not limited to, the following:
 - a. ITW Insulation Systems; Gerrard Strapping and Seals.
 - b. RPR Products, Inc.; Insul-Mate Strapping, Seals, and Springs.
2. Stainless Steel: ASTM A 167 or ASTM A 240/A 240M, Type 304; 0.015 inch thick, 1/2 inch wing seal or closed seal.
3. Aluminum: ASTM B 209, Alloy 3003, 3005, 3105, or 5005; Temper H-14, 0.020 inch thick, 1/2 inch wide with wing seal or closed seal.
4. Springs: Twin spring set constructed of stainless steel with ends flat and slotted to accept metal bands. Spring size determined by manufacturer for application.

B. Insulation Pins and Hangers:

1. Capacitor-Discharge-Weld Pins: Copper- or zinc-coated steel pin, fully annealed for capacitor-discharge welding, 0.106-inch-diameter shank, length to suit depth of insulation indicated.
 - a. Products: Subject to compliance with requirements, available products that may be incorporated into the Work include, but are not limited to, the following:
 - 1) AGM Industries, Inc.; CWP-1.
 - 2) GEMCO; CD.
 - 3) Midwest Fasteners, Inc.; CD.
 - 4) Nelson Stud Welding; TPA, TPC, and TPS.
2. Cupped-Head, Capacitor-Discharge-Weld Pins: Copper- or zinc-coated steel pin, fully annealed for capacitor-discharge welding, 0.106-inch-diameter shank, length to suit depth of insulation indicated with integral 1-1/2-inch galvanized carbon-steel washer.
 - a. Products: Subject to compliance with requirements, available products that may be incorporated into the Work include, but are not limited to, the following:
 - 1) AGM Industries, Inc.; CHP-1.
 - 2) GEMCO; Cupped Head Weld Pin.
 - 3) Midwest Fasteners, Inc.; Cupped Head.
 - 4) Nelson Stud Welding; CHP.
3. Metal, Adhesively Attached, Perforated-Base Insulation Hangers: Baseplate welded to projecting spindle that is capable of holding insulation, of thickness indicated, securely in position indicated when self-locking washer is in place.

- a. Products: Subject to compliance with requirements, available products that may be incorporated into the Work include, but are not limited to, the following]:
 - 1) AGM Industries, Inc.; Tactoo Perforated Base Insul-Hangers.
 - 2) GEMCO; Perforated Base.
 - 3) Midwest Fasteners, Inc.; Spindle.
 - b. Baseplate: Perforated, galvanized carbon-steel sheet, 0.030 inch thick by 2 inches square.
 - c. Spindle: Copper- or zinc-coated, low-carbon steel, fully annealed, 0.106-inch-diameter shank, length to suit depth of insulation indicated.
 - d. Adhesive: Recommended by hanger manufacturer. Product with demonstrated capability to bond insulation hanger securely to substrates indicated without damaging insulation, hangers, and substrates.
4. Insulation-Retaining Washers: Self-locking washers formed from 0.016-inch-thick, galvanized-steel sheet, with beveled edge sized as required to hold insulation securely in place but not less than 1-1/2 inches in diameter.
- a. Products: Subject to compliance with requirements, available products that may be incorporated into the Work include, but are not limited to, the following:
 - 1) AGM Industries, Inc.; RC-150.
 - 2) GEMCO; R-150.
 - 3) Midwest Fasteners, Inc.; WA-150.
 - 4) Nelson Stud Welding; Speed Clips.
 - b. Protect ends with capped self-locking washers incorporating a spring steel insert to ensure permanent retention of cap in exposed locations.
- C. Staples: Outward-clinching insulation staples, nominal 3/4-inch-wide, stainless steel or Monel.

2.9 CORNER ANGLES

- A. Aluminum Corner Angles: 0.040 inch thick, minimum 1 by 1 inch, aluminum according to ASTM B 209, Alloy 3003, 3005, 3105, or 5005; Temper H-14.

PART 3 - EXECUTION

3.1 EXAMINATION

- A. Examine substrates and conditions for compliance with requirements for installation tolerances and other conditions affecting performance of insulation application.

1. Verify that systems and equipment to be insulated have been tested and are free of defects.
 2. Verify that surfaces to be insulated are clean and dry.
- B. Proceed with installation only after unsatisfactory conditions have been corrected.

3.2 PREPARATION

- A. Surface Preparation: Clean and dry surfaces to receive insulation. Remove materials that will adversely affect insulation application.
- B. Surface Preparation: Clean and prepare surfaces to be insulated. Before insulating, apply a corrosion coating to insulated surfaces as follows:
1. Carbon Steel: Coat carbon steel operating at a service temperature between 32 and 300 deg F with an epoxy coating. Consult coating manufacturer for appropriate coating materials and application methods for operating temperature range.
- C. Coordinate insulation installation with the trade installing heat tracing. Comply with requirements for heat tracing that apply to insulation.
- D. Mix insulating cements with clean potable water; if insulating cements are to be in contact with stainless-steel surfaces, use demineralized water.

3.3 GENERAL INSTALLATION REQUIREMENTS

- A. Install insulation materials, accessories, and finishes with smooth, straight, and even surfaces; free of voids throughout the length of equipment.
- B. Install insulation materials, forms, vapor barriers or retarders, jackets, and thicknesses required for each item of equipment as specified in insulation system schedules.
- C. Install accessories compatible with insulation materials and suitable for the service. Install accessories that do not corrode, soften, or otherwise attack insulation or jacket in either wet or dry state.
- D. Install insulation with longitudinal seams at top and bottom of horizontal runs.
- E. Install multiple layers of insulation with longitudinal and end seams staggered.
- F. Keep insulation materials dry during application and finishing.
- G. Install insulation with tight longitudinal seams and end joints. Bond seams and joints with adhesive recommended by insulation material manufacturer.
- H. Install insulation with least number of joints practical.

- I. Where vapor barrier is indicated, seal joints, seams, and penetrations in insulation at hangers, supports, anchors, and other projections with vapor-barrier mastic.
 - 1. Install insulation continuously through hangers and around anchor attachments.
 - 2. For insulation application where vapor barriers are indicated, extend insulation on anchor legs from point of attachment to supported item to point of attachment to structure. Taper and seal ends at attachment to structure with vapor-barrier mastic.
 - 3. Install insert materials and install insulation to tightly join the insert. Seal insulation to insulation inserts with adhesive or sealing compound recommended by insulation material manufacturer.
 - 4. Cover inserts with jacket material matching adjacent insulation. Install shields over jacket, arranged to protect jacket from tear or puncture by hanger, support, and shield.

- J. Apply adhesives, mastics, and sealants at manufacturer's recommended coverage rate and wet and dry film thicknesses.

- K. Install insulation with factory-applied jackets as follows:
 - 1. Draw jacket tight and smooth.
 - 2. Cover circumferential joints with 3-inch-wide strips, of same material as insulation jacket. Secure strips with adhesive and outward clinching staples along both edges of strip, spaced 4 inches o.c.
 - 3. Overlap jacket longitudinal seams at least 1-1/2 inches. Clean and dry surface to receive self-sealing lap. Staple laps with outward clinching staples along edge at 4 inches o.c.
 - a. For below ambient services, apply vapor-barrier mastic over staples.
 - 4. Cover joints and seams with tape, according to insulation material manufacturer's written instructions, to maintain vapor seal.
 - 5. Where vapor barriers are indicated, apply vapor-barrier mastic on seams and joints.

- L. Cut insulation in a manner to avoid compressing insulation more than 75 percent of its nominal thickness.

- M. Finish installation with systems at operating conditions. Repair joint separations and cracking due to thermal movement.

- N. Repair damaged insulation facings by applying same facing material over damaged areas. Extend patches at least 4 inches beyond damaged areas. Adhere, staple, and seal patches similar to butt joints.

- O. For above ambient services, do not install insulation to the following:
 - 1. Vibration-control devices.
 - 2. Testing agency labels and stamps.
 - 3. Nameplates and data plates.

4. Manholes.
5. Handholes.
6. Cleanouts.

3.4 INSTALLATION OF EQUIPMENT, TANK, AND VESSEL INSULATION

A. Mineral-Fiber, Pipe and Tank Insulation Installation for Tanks and Vessels: Secure insulation with adhesive and anchor pins and speed washers.

1. Apply adhesives according to manufacturer's recommended coverage rates per unit area, for 100 percent coverage of tank and vessel surfaces.
2. Groove and score insulation materials to fit as closely as possible to equipment, including contours. Bevel insulation edges for cylindrical surfaces for tight joints. Stagger end joints.
3. Protect exposed corners with secured corner angles.
4. Install adhesively attached or self-sticking insulation hangers and speed washers on sides of tanks and vessels as follows:
 - a. Do not weld anchor pins to ASME-labeled pressure vessels.
 - b. Select insulation hangers and adhesive that are compatible with service temperature and with substrate.
 - c. On tanks and vessels, maximum anchor-pin spacing is 3 inches from insulation end joints, and 16 inches o.c. in both directions.
 - d. Do not overcompress insulation during installation.
 - e. Cut and miter insulation segments to fit curved sides and domed heads of tanks and vessels.
 - f. Impale insulation over anchor pins and attach speed washers.
 - g. Cut excess portion of pins extending beyond speed washers or bend parallel with insulation surface. Cover exposed pins and washers with tape matching insulation facing.
5. Secure each layer of insulation with stainless-steel or aluminum bands. Select band material compatible with insulation materials.
6. Install insulation in removable segments on equipment access doors, manholes, handholes, and other elements that require frequent removal for service and inspection.
7. Bevel and seal insulation ends around manholes, handholes, ASME stamps, and nameplates.
8. For equipment with surface temperatures below ambient, apply mastic to open ends, joints, seams, breaks, and punctures in insulation.

B. Flexible Elastomeric Thermal Insulation Installation for Tanks and Vessels: Install insulation over entire surface of tanks and vessels.

1. Apply 100 percent coverage of adhesive to surface with manufacturer's recommended adhesive.
2. Seal longitudinal seams and end joints.

3.5 FIELD QUALITY CONTROL

- A. Testing Agency: Engage a qualified testing agency to perform tests and inspections.
- B. Perform tests and inspections.
- C. Tests and Inspections: Inspect field-insulated equipment, randomly selected by Architect, by removing field-applied jacket and insulation in layers in reverse order of their installation. Extent of inspection shall be limited to one location for each type of equipment defined in the "Equipment Insulation Schedule" Article. For large equipment, remove only a portion adequate to determine compliance.
- D. All insulation applications will be considered defective Work if sample inspection reveals noncompliance with requirements.

3.6 EQUIPMENT INSULATION SCHEDULE

- A. Insulation materials and thicknesses are identified below. If more than one material is listed for a type of equipment, selection from materials listed is Contractor's option.
- B. Insulate existing indoor equipment that is currently insulated.
- C. Steam condensate pump additional insulation shall be one of the following:
 - 1. Mineral-Fiber Board: 2 inches thick and 3-lb/cu. ft. nominal density.
 - 2. Mineral-Fiber Pipe and Tank: 2 inches thick.
- D. Steam condensate tank and receiver additional insulation shall be the following:
 - 1. Mineral-Fiber Board: 2 inches thick and 3-lb/cu. ft. nominal density.
 - 2. Mineral-Fiber Pipe and Tank: 2 inches thick.
- E. Steam flash-tank additional insulation shall be one of the following:
 - 1. Mineral-Fiber Board: 2 inches thick and 3-lb/cu. ft. nominal density.
 - 2. Mineral-Fiber Pipe and Tank: 2 inches thick.
- F. Steam Tunnel Wall and Ceiling shall be the following:
 - 1. Mineral-Fiber Board: 4 inches thick and 3-lb/cu. ft. nominal density with FSK jacket..

END OF SECTION 230716

SECTION 230719

HVAC PIPING INSULATION

PART 1 - GENERAL

1.1 RELATED DOCUMENTS

- A. Drawings and general provisions of the Contract, including General and Supplementary Conditions and Division 01 Specification Sections, apply to this Section.

1.2 SUMMARY

- A. Section includes insulating the following HVAC piping systems:
 - 1. Steam and steam condensate piping, indoors.
- B. Related Sections:
 - 1. Section 230713 "Duct Insulation."

1.3 ACTION SUBMITTALS

- A. Product Data: For each type of product indicated. Include thermal conductivity, water-vapor permeance thickness, and jackets (both factory and field applied if any).
- B. Shop Drawings: Include plans, elevations, sections, details, and attachments to other work.
 - 1. Detail application of protective shields, saddles, and inserts at hangers for each type of insulation and hanger.
 - 2. Detail attachment and covering of heat tracing inside insulation.
 - 3. Detail insulation application at pipe expansion joints for each type of insulation.
 - 4. Detail insulation application at elbows, fittings, flanges, valves, and specialties for each type of insulation.
 - 5. Detail removable insulation at piping specialties.
 - 6. Detail application of field-applied jackets.
 - 7. Detail application at linkages of control devices.

1.4 INFORMATIONAL SUBMITTALS

- A. Qualification Data: For qualified Installer.
- B. Material Test Reports: From a qualified testing agency acceptable to authorities having jurisdiction indicating, interpreting, and certifying test results for compliance of

insulation materials, sealers, attachments, cements, and jackets, with requirements indicated. Include dates of tests and test methods employed.

- C. Field quality-control reports.

1.5 QUALITY ASSURANCE

- A. Installer Qualifications: Skilled mechanics who have successfully completed an apprenticeship program or another craft training program certified by the Department of Labor, Bureau of Apprenticeship and Training.
- B. Surface-Burning Characteristics: For insulation and related materials, as determined by testing identical products according to ASTM E 84, by a testing and inspecting agency acceptable to authorities having jurisdiction. Factory label insulation and jacket materials and adhesive, mastic, tapes, and cement material containers, with appropriate markings of applicable testing agency.
 - 1. Insulation Installed Indoors: Flame-spread index of 25 or less, and smoke-developed index of 50 or less.
 - 2. Insulation Installed Outdoors: Flame-spread index of 75 or less, and smoke-developed index of 150 or less.

1.6 DELIVERY, STORAGE, AND HANDLING

- A. Packaging: Insulation material containers shall be marked by manufacturer with appropriate ASTM standard designation, type and grade, and maximum use temperature.

1.7 COORDINATION

- A. Coordinate sizes and locations of supports, hangers, and insulation shields specified in Section 230529 "Hangers and Supports for HVAC Piping and Equipment."
- B. Coordinate clearance requirements with piping Installer for piping insulation application. Before preparing piping Shop Drawings, establish and maintain clearance requirements for installation of insulation and field-applied jackets and finishes and for space required for maintenance.

1.8 SCHEDULING

- A. Schedule insulation application after pressure testing systems and, where required, after installing and testing heat tracing. Insulation application may begin on segments that have satisfactory test results.
- B. Complete installation and concealment of plastic materials as rapidly as possible in each area of construction.

PART 2 - PRODUCTS

2.1 INSULATION MATERIALS

- A. Comply with requirements in "Piping Insulation Schedule, General," "Indoor Piping Insulation Schedule," "Outdoor, Aboveground Piping Insulation Schedule," and "Outdoor, Underground Piping Insulation Schedule" articles for where insulating materials shall be applied.
- B. Products shall not contain asbestos, lead, mercury, or mercury compounds.
- C. Products that come in contact with stainless steel shall have a leachable chloride content of less than 50 ppm when tested according to ASTM C 871.
- D. Insulation materials for use on austenitic stainless steel shall be qualified as acceptable according to ASTM C 795.
- E. Foam insulation materials shall not use CFC or HCFC blowing agents in the manufacturing process.
- F. Mineral-Fiber, Preformed Pipe Insulation:
 - 1. Products: Subject to compliance with requirements, available products that may be incorporated into the Work include, but are not limited to, the following:
 - a. Johns Manville.
 - b. Knauf Insulation.
 - c. Manson Insulation Inc.
 - d. Owens Corning.
 - 2. Type II, 1200 deg F Materials: Mineral or glass fibers bonded with a thermosetting resin. Comply with ASTM C 547, Type II, Grade A, with factory-applied ASJ. Factory-applied jacket requirements are specified in "Factory-Applied Jackets" Article.

2.2 INSULATING CEMENTS

- A. Mineral-Fiber Insulating Cement: Comply with ASTM C 195.
 - 1. Products: Subject to compliance with requirements, available products that may be incorporated into the Work include, but are not limited to, the following:
 - a. Ramco Insulation, Inc.; Super-Stik.
- B. Mineral-Fiber, Hydraulic-Setting Insulating and Finishing Cement: Comply with ASTM C 449.
 - 1. Products: Subject to compliance with requirements, available products that may be incorporated into the Work include, but are not limited to, the following:

- a. Ramco Insulation, Inc.; Ramcote 1200 and Quik-Cote.

2.3 ADHESIVES

- A. Materials shall be compatible with insulation materials, jackets, and substrates and for bonding insulation to itself and to surfaces to be insulated unless otherwise indicated.
- B. Mineral-Fiber Adhesive: Comply with MIL-A-3316C, Class 2, Grade A.
 1. Products: Subject to compliance with requirements, available products that may be incorporated into the Work include, but are not limited to, the following:
 - a. Childers Brand, Specialty Construction Brands, Inc., a business of H. B. Fuller Company; CP-127.
 - b. - Marathon Industries; 225.
 - c. Foster Brand, Specialty Construction Brands, Inc., a business of H. B. Fuller Company; 85-60/85-70.
 - d. Mon-Eco Industries, Inc.; 22-25.
 2. For indoor applications, adhesive shall have a VOC content of 80 g/L or less when calculated according to 40 CFR 59, Subpart D (EPA Method 24).
 3. Adhesive shall comply with the testing and product requirements of the California Department of Health Services' "Standard Practice for the Testing of Volatile Organic Emissions from Various Sources Using Small-Scale Environmental Chambers."
- C. ASJ Adhesive: Comply with MIL-A-3316C, Class 2, Grade A for bonding insulation jacket lap seams and joints.
 1. Products: Subject to compliance with requirements, available products that may be incorporated into the Work include, but are not limited to, the following:
 - a. Childers Brand, Specialty Construction Brands, Inc., a business of H. B. Fuller Company; CP-82.
 - b. - Marathon Industries; 225.
 - c. Foster Brand, Specialty Construction Brands, Inc., a business of H. B. Fuller Company; 85-50.
 - d. Mon-Eco Industries, Inc.; 22-25.
 2. For indoor applications, adhesive shall have a VOC content of 50 g/L or less when calculated according to 40 CFR 59, Subpart D (EPA Method 24).
 3. Adhesive shall comply with the testing and product requirements of the California Department of Health Services' "Standard Practice for the Testing of Volatile Organic Emissions from Various Sources Using Small-Scale Environmental Chambers."

2.4 MASTICS

- A. Materials shall be compatible with insulation materials, jackets, and substrates; comply with MIL-PRF-19565C, Type II.
 - 1. For indoor applications, use mastics that have a VOC content of 50 g/L or less when calculated according to 40 CFR 59, Subpart D (EPA Method 24).
- B. Breather Mastic: Water based; suitable for indoor and outdoor use on above-ambient services.
 - 1. Products: Subject to compliance with requirements, available products that may be incorporated into the Work include, but are not limited to, the following:
 - a. Childers Brand, Specialty Construction Brands, Inc., a business of H. B. Fuller Company; CP-10.
 - b. - Marathon Industries; 550.
 - c. Foster Brand, Specialty Construction Brands, Inc., a business of H. B. Fuller Company; 46-50.
 - d. Mon-Eco Industries, Inc.; 55-50.
 - e. Vimasco Corporation; WC-1/WC-5.
 - 2. Water-Vapor Permeance: ASTM F 1249, 1.8 perms at 0.0625-inch dry film thickness.
 - 3. Service Temperature Range: Minus 20 to plus 180 deg F.
 - 4. Solids Content: 60 percent by volume and 66 percent by weight.
 - 5. Color: White.

2.5 LAGGING ADHESIVES

- A. Description: Comply with MIL-A-3316C, Class I, Grade A and shall be compatible with insulation materials, jackets, and substrates.
 - 1. For indoor applications, use lagging adhesives that have a VOC content of 50 g/L or less when calculated according to 40 CFR 59, Subpart D (EPA Method 24).
 - 2. Products: Subject to compliance with requirements, available products that may be incorporated into the Work include, but are not limited to, the following:
 - a. Childers Brand, Specialty Construction Brands, Inc., a business of H. B. Fuller Company; CP-50 AHV2.
 - b. Foster Brand, Specialty Construction Brands, Inc., a business of H. B. Fuller Company; 30-36.
 - c. Vimasco Corporation; 713 and 714.
 - 3. Fire-resistant, water-based lagging adhesive and coating for use indoors to adhere fire-resistant lagging cloths over pipe insulation.
 - 4. Service Temperature Range: 0 to plus 180 deg F.
 - 5. Color: White.

2.6 SEALANTS

A. Joint Sealants:

1. Materials shall be compatible with insulation materials, jackets, and substrates.
2. Permanently flexible, elastomeric sealant.
3. Service Temperature Range: Minus 100 to plus 300 deg F.
4. Color: White or gray.
5. For indoor applications, sealants shall have a VOC content of 420 g/L or less when calculated according to 40 CFR 59, Subpart D (EPA Method 24).
6. Sealants shall comply with the testing and product requirements of the California Department of Health Services' "Standard Practice for the Testing of Volatile Organic Emissions from Various Sources Using Small-Scale Environmental Chambers."

B. ASJ Flashing Sealants:

1. Products: Subject to compliance with requirements, available products that may be incorporated into the Work include, but are not limited to, the following:
 - a. Childers Brand, Specialty Construction Brands, Inc., a business of H. B. Fuller Company; CP-76.
2. Materials shall be compatible with insulation materials, jackets, and substrates.
3. Fire- and water-resistant, flexible, elastomeric sealant.
4. Service Temperature Range: Minus 40 to plus 250 deg F.
5. Color: White.
6. For indoor applications, sealants shall have a VOC content of 420 g/L or less when calculated according to 40 CFR 59, Subpart D (EPA Method 24).
7. Sealants shall comply with the testing and product requirements of the California Department of Health Services' "Standard Practice for the Testing of Volatile Organic Emissions from Various Sources Using Small-Scale Environmental Chambers."

2.7 FACTORY-APPLIED JACKETS

A. Insulation system schedules indicate factory-applied jackets on various applications. When factory-applied jackets are indicated, comply with the following:

1. ASJ: White, kraft-paper, fiberglass-reinforced scrim with aluminum-foil backing; complying with ASTM C 1136, Type I.

2.8 TAPES

A. ASJ Tape: White vapor-retarder tape matching factory-applied jacket with acrylic adhesive, complying with ASTM C 1136.

1. Products: Subject to compliance with requirements, available products that may be incorporated into the Work include, but are not limited to, the following:
 - a. ABI, Ideal Tape Division; 428 AWF ASJ.
 - b. Avery Dennison Corporation, Specialty Tapes Division; Fasson 0836.
 - c. Compac Corporation; 104 and 105.
 - d. Venture Tape; 1540 CW Plus, 1542 CW Plus, and 1542 CW Plus/SQ.
2. Width: 3 inches.
3. Thickness: 11.5 mils.
4. Adhesion: 90 ounces force/inch in width.
5. Elongation: 2 percent.
6. Tensile Strength: 40 lbf/inch in width.
7. ASJ Tape Disks and Squares: Precut disks or squares of ASJ tape.

2.9 SECUREMENTS

A. Bands:

1. Products: Subject to compliance with requirements, available products that may be incorporated into the Work include, but are not limited to, the following:
 - a. ITW Insulation Systems; Gerrard Strapping and Seals.
 - b. RPR Products, Inc.; Insul-Mate Strapping, Seals, and Springs.
- 2.
3. Aluminum: ASTM B 209, Alloy 3003, 3005, 3105, or 5005; Temper H-14, 0.020 inch thick, 1/2 inchwide with wing seal or closed seal.
4. Springs: Twin spring set constructed of stainless steel with ends flat and slotted to accept metal bands. Spring size determined by manufacturer for application.

B. Staples: Outward-clinching insulation staples, nominal 3/4-inch-wide, stainless steel or Monel.

PART 3 - EXECUTION

3.1 EXAMINATION

- A. Examine substrates and conditions for compliance with requirements for installation tolerances and other conditions affecting performance of insulation application.
 1. Verify that systems to be insulated have been tested and are free of defects.
 2. Verify that surfaces to be insulated are clean and dry.
 3. Proceed with installation only after unsatisfactory conditions have been corrected.

3.2 PREPARATION

- A. Surface Preparation: Clean and dry surfaces to receive insulation. Remove materials that will adversely affect insulation application.
- B. Surface Preparation: Clean and prepare surfaces to be insulated. Before insulating, apply a corrosion coating to insulated surfaces as follows:
 - 1. Carbon Steel: Coat carbon steel operating at a service temperature between 32 and 300 deg F with an epoxy coating. Consult coating manufacturer for appropriate coating materials and application methods for operating temperature range.
- C. Mix insulating cements with clean potable water; if insulating cements are to be in contact with stainless-steel surfaces, use demineralized water.

3.3 GENERAL INSTALLATION REQUIREMENTS

- A. Install insulation materials, accessories, and finishes with smooth, straight, and even surfaces; free of voids throughout the length of piping including fittings, valves, and specialties.
- B. Install insulation materials, forms, vapor barriers or retarders, jackets, and thicknesses required for each item of pipe system as specified in insulation system schedules.
- C. Install accessories compatible with insulation materials and suitable for the service. Install accessories that do not corrode, soften, or otherwise attack insulation or jacket in either wet or dry state.
- D. Install insulation with longitudinal seams at top and bottom of horizontal runs.
- E. Install multiple layers of insulation with longitudinal and end seams staggered.
- F. Do not weld brackets, clips, or other attachment devices to piping, fittings, and specialties.
- G. Keep insulation materials dry during application and finishing.
- H. Install insulation with tight longitudinal seams and end joints. Bond seams and joints with adhesive recommended by insulation material manufacturer.
- I. Install insulation with least number of joints practical.
- J. Apply adhesives, mastics, and sealants at manufacturer's recommended coverage rate and wet and dry film thicknesses.
- K. Install insulation with factory-applied jackets as follows:
 - 1. Draw jacket tight and smooth.

2. Cover circumferential joints with 3-inch-wide strips, of same material as insulation jacket. Secure strips with adhesive and outward clinching staples along both edges of strip, spaced 4 inches o.c.
 3. Overlap jacket longitudinal seams at least 1-1/2 inches. Install insulation with longitudinal seams at bottom of pipe. Clean and dry surface to receive self-sealing lap. Staple laps with outward clinching staples along edge at 4 inches o.c.
 4. Cover joints and seams with tape, according to insulation material manufacturer's written instructions, to maintain vapor seal.
 5. Where vapor barriers are indicated, apply vapor-barrier mastic on seams and joints and at ends adjacent to pipe flanges and fittings.
- L. Cut insulation in a manner to avoid compressing insulation more than 75 percent of its nominal thickness.
- M. Finish installation with systems at operating conditions. Repair joint separations and cracking due to thermal movement.
- N. Repair damaged insulation facings by applying same facing material over damaged areas. Extend patches at least 4 inches beyond damaged areas. Adhere, staple, and seal patches similar to butt joints.
- O. For above-ambient services, do not install insulation to the following:
1. Vibration-control devices.
 2. Testing agency labels and stamps.
 3. Nameplates and data plates.
 4. Manholes.
 5. Handholes.
 6. Cleanouts.

3.4 PENETRATIONS

- A. Insulation Installation at Interior Wall and Partition Penetrations: Install insulation continuously through walls and partitions.

3.5 GENERAL PIPE INSULATION INSTALLATION

- A. Requirements in this article generally apply to all insulation materials except where more specific requirements are specified in various pipe insulation material installation articles.
- B. Insulation Installation on Fittings, Valves, Strainers, Flanges, and Unions:
1. Install insulation over fittings, valves, strainers, flanges, unions, and other specialties with continuous thermal and vapor-retarder integrity unless otherwise indicated.

2. Insulate pipe elbows using preformed fitting insulation or mitered fittings made from same material and density as adjacent pipe insulation. Each piece shall be butted tightly against adjoining piece and bonded with adhesive. Fill joints, seams, voids, and irregular surfaces with insulating cement finished to a smooth, hard, and uniform contour that is uniform with adjoining pipe insulation.
 3. Insulate tee fittings with preformed fitting insulation or sectional pipe insulation of same material and thickness as used for adjacent pipe. Cut sectional pipe insulation to fit. Butt each section closely to the next and hold in place with tie wire. Bond pieces with adhesive.
 4. Insulate valves using preformed fitting insulation or sectional pipe insulation of same material, density, and thickness as used for adjacent pipe. Overlap adjoining pipe insulation by not less than two times the thickness of pipe insulation, or one pipe diameter, whichever is thicker. For valves, insulate up to and including the bonnets, valve stuffing-box studs, bolts, and nuts. Fill joints, seams, and irregular surfaces with insulating cement.
 5. Insulate strainers using preformed fitting insulation or sectional pipe insulation of same material, density, and thickness as used for adjacent pipe. Overlap adjoining pipe insulation by not less than two times the thickness of pipe insulation, or one pipe diameter, whichever is thicker. Fill joints, seams, and irregular surfaces with insulating cement. Insulate strainers so strainer basket flange or plug can be easily removed and replaced without damaging the insulation and jacket. Provide a removable reusable insulation cover. For below-ambient services, provide a design that maintains vapor barrier.
 6. Insulate flanges and unions using a section of oversized preformed pipe insulation. Overlap adjoining pipe insulation by not less than two times the thickness of pipe insulation, or one pipe diameter, whichever is thicker.
 7. Cover segmented insulated surfaces with a layer of finishing cement and coat with a mastic. Install vapor-barrier mastic for below-ambient services and a breather mastic for above-ambient services. Reinforce the mastic with fabric-reinforcing mesh. Trowel the mastic to a smooth and well-shaped contour.
 8. For services not specified to receive a field-applied jacket except for flexible elastomeric and polyolefin, install fitted PVC cover over elbows, tees, strainers, valves, flanges, and unions. Terminate ends with PVC end caps. Tape PVC covers to adjoining insulation facing using PVC tape.
 9. Stencil or label the outside insulation jacket of each union with the word "union." Match size and color of pipe labels.
- C. Insulate instrument connections for thermometers, pressure gages, pressure temperature taps, test connections, flow meters, sensors, switches, and transmitters on insulated pipes. Shape insulation at these connections by tapering it to and around the connection with insulating cement and finish with finishing cement, mastic, and flashing sealant.
- D. Install removable insulation covers at locations indicated. Installation shall conform to the following:
1. Make removable flange and union insulation from sectional pipe insulation of same thickness as that on adjoining pipe. Install same insulation jacket as adjoining pipe insulation.

2. When flange and union covers are made from sectional pipe insulation, extend insulation from flanges or union long at least two times the insulation thickness over adjacent pipe insulation on each side of flange or union. Secure flange cover in place with stainless-steel or aluminum bands. Select band material compatible with insulation and jacket.
3. Construct removable valve insulation covers in same manner as for flanges, except divide the two-part section on the vertical center line of valve body.
4. When covers are made from block insulation, make two halves, each consisting of mitered blocks wired to stainless-steel fabric. Secure this wire frame, with its attached insulation, to flanges with tie wire. Extend insulation at least 2 inches over adjacent pipe insulation on each side of valve. Fill space between flange or union cover and pipe insulation with insulating cement. Finish cover assembly with insulating cement applied in two coats. After first coat is dry, apply and trowel second coat to a smooth finish.

3.6 INSTALLATION OF MINERAL-FIBER INSULATION

A. Insulation Installation on Straight Pipes and Tubes:

1. Secure each layer of preformed pipe insulation to pipe with wire or bands and tighten bands without deforming insulation materials.
2. Where vapor barriers are indicated, seal longitudinal seams, end joints, and protrusions with vapor-barrier mastic and joint sealant.
3. For insulation with factory-applied jackets on above-ambient surfaces, secure laps with outward-clinched staples at 6 inches o.c.
4. For insulation with factory-applied jackets on below-ambient surfaces, do not staple longitudinal tabs. Instead, secure tabs with additional adhesive as recommended by insulation material manufacturer and seal with vapor-barrier mastic and flashing sealant.

B. Insulation Installation on Pipe Flanges:

1. Install preformed pipe insulation to outer diameter of pipe flange.
2. Make width of insulation section same as overall width of flange and bolts, plus twice the thickness of pipe insulation.
3. Fill voids between inner circumference of flange insulation and outer circumference of adjacent straight pipe segments with mineral-fiber blanket insulation.
4. Install jacket material with manufacturer's recommended adhesive, overlap seams at least 1 inch, and seal joints with flashing sealant.

C. Insulation Installation on Pipe Fittings and Elbows:

1. Install preformed sections of same material as straight segments of pipe insulation when available.
2. When preformed insulation elbows and fittings are not available, install mitered sections of pipe insulation, to a thickness equal to adjoining pipe insulation. Secure insulation materials with wire or bands.

D. Insulation Installation on Valves and Pipe Specialties:

1. Install preformed sections of same material as straight segments of pipe insulation when available.
2. When preformed sections are not available, install mitered sections of pipe insulation to valve body.
3. Arrange insulation to permit access to packing and to allow valve operation without disturbing insulation.
4. Install insulation to flanges as specified for flange insulation application.

3.7 FIELD QUALITY CONTROL

- A. Testing Agency: Engage a qualified testing agency to perform tests and inspections.
- B. Perform tests and inspections.
- C. Tests and Inspections:
 1. Inspect pipe, fittings, strainers, and valves, randomly selected by Architect, by removing field-applied jacket and insulation in layers in reverse order of their installation. Extent of inspection shall be limited to three locations of straight pipe, three locations of threaded fittings, three locations of welded fittings, two locations of threaded strainers, two locations of welded strainers, three locations of threaded valves, and three locations of flanged valves for each pipe service defined in the "Piping Insulation Schedule, General" Article.
- D. All insulation applications will be considered defective Work if sample inspection reveals noncompliance with requirements.

3.8 PIPING INSULATION SCHEDULE, GENERAL

- A. Acceptable preformed pipe and tubular insulation materials and thicknesses are identified for each piping system and pipe size range. If more than one material is listed for a piping system, selection from materials listed is Contractor's option.
- B. Items Not Insulated: Unless otherwise indicated, do not install insulation on the following:
 1. Drainage piping located in crawl spaces.
 2. Underground piping.
 3. Chrome-plated pipes and fittings unless there is a potential for personnel injury.

3.9 INDOOR PIPING INSULATION SCHEDULE

- A. Steam and Steam Condensate (New and Existing), 350 Deg F and Below:
 1. NPS 3/4 and Smaller: Insulation shall be the following:

- a. Mineral-Fiber, Preformed Pipe, Type II: 3inches thick for new piping. Add 2 inches (50 mm) thick insulation to existing insulation.
2. NPS 1 and Larger: Insulation shall be the following:
 - a. Mineral-Fiber, Preformed Pipe, Type II: 4.5inches thick for new piping. . Add 2 inches (50 mm) thick insulation to existing insulation.

3.10 INDOOR, FIELD-APPLIED JACKET SCHEDULE

- A. Install jacket over insulation material. For insulation with factory-applied jacket, install the field-applied jacket over the factory-applied jacket.
- B. If more than one material is listed, selection from materials listed is Contractor's option.
- C. Piping, Concealed:
 1. None.
- D. Piping, Exposed:
 1. None.

END OF SECTION 230719

SECTION 23 09 00 - INSTRUMENTATION AND CONTROL FOR HVAC

PART 1 - GENERAL

1.1 RELATED DOCUMENTS

- A. Drawings and general provisions of the Contract, including General and Supplementary Conditions and Division 01 Specification Sections, apply to this Section.

1.2 SUMMARY

- A. This Section includes control equipment for HVAC systems and components, including control components for terminal heating and cooling units not supplied with factory-wired controls.
- B. Related Sections include the following:
 - 1. Section 23 05 19 "Meters and Gages for HVAC Piping" for measuring equipment that relates to this Section.
 - 2. Other Division 22, 23, and 26 Sections for field-installed controls devices and interface requirements with the DDC system.

1.3 DEFINITIONS

- A. BMS: Building Management System
- B. Control Devices: Valves, dampers, variable frequency drives, and other appurtenances that change the properties and henceforth vary the conditions of the controlled parameter, such as temperature, air flow, and pressure.
- C. DDC: Direct digital control.
- D. I/O: Input/output.
- E. LonWorks: A control network technology platform for designing and implementing interoperable control devices and networks.
- F. MS/TP: Master slave/token passing. The Master-Slave/Token-Passing EIA-485 LAN developed for BACnet by ASHRAE. Operates at 9600, 19.2K, 38.4K and 76.8 K BPS. Master nodes (devices) pass around a speaking token which entitles the holder to initiate BACnet messages. Slave nodes can only respond to messages from Masters.
- G. Native BACnet: A Building Automation System that uses the BACnet protocol for its data transfer between hardware devices.

- H. PC: Personal computer.
- I. PID: Proportional plus integral plus derivative.
- J. RTD: Resistance temperature detector.

1.4 SYSTEM PERFORMANCE

A. Comply with the following performance requirements:

1. Graphic Display: Display graphic with minimum 20 dynamic points with current data within 10 seconds.
2. Graphic Refresh: Update graphic with minimum 20 dynamic points with current data within 8 seconds and with automatic refresh every 15 seconds.
3. Configuration and Tuning Screens: Refresh screens used for configuring, calibrating, or tuning points, PID loops, and similar control logic automatically within 6 seconds.
4. Object Command: Reaction time of less than two seconds between operator command of a binary object and device reaction.
5. Object Scan: Transmit change of state and change of analog values to control units or workstation within six seconds.
6. Alarm Response Time: Annunciate alarm at workstation within 45 seconds. Multiple workstations must receive alarms within five seconds of each other.
7. Program Execution Frequency: Run capability of applications as often as five seconds, but selected consistent with mechanical process under control.
8. Performance: Programmable controllers shall execute DDC PID control loops, and scan and update process values and outputs at least once per second.
9. Reporting Accuracy and Stability of Control: Report values and maintain measured variables within tolerances as follows:
 - a. Water Temperature: Plus or minus 1 deg F .
 - b. Water Flow: Plus or minus 5 percent of full scale.
 - c. Water Pressure: Plus or minus 2 percent of full scale.
 - d. Space Temperature: Plus or minus 1 deg F .
 - e. Ducted Air Temperature: Plus or minus 1 deg F .
 - f. Outside Air Temperature: Plus or minus 2 deg F .
 - g. Dew Point Temperature: Plus or minus 3 deg F .
 - h. Temperature Differential: Plus or minus 0.25 deg F .
 - i. Relative Humidity: Plus or minus 5 percent.
 - j. Airflow (Pressurized Spaces): Plus or minus 3 percent of full scale.
 - k. Airflow (Measuring Stations): Plus or minus 5 percent of full scale.
 - l. Airflow (Terminal): Plus or minus 10 percent of full scale.
 - m. Air Pressure (Space): Plus or minus 0.01-inch wg .
 - n. Air Pressure (Ducts): Plus or minus 0.1-inch wg .
 - o. Carbon Monoxide: Plus or minus 5 percent of reading.
 - p. Carbon Dioxide: Plus or minus 50 ppm.
 - q. Electrical: Plus or minus 5 percent of reading.

1.5 ACTION SUBMITTALS

- A. Product Data: Include manufacturer's technical literature for each type of product. Indicate dimensions, capacities, performance characteristics, electrical characteristics, finishes for materials, and installation and startup instructions for each type of product indicated.
1. DDC System Hardware: Bill of materials of equipment indicating quantity, manufacturer, and model number. Include technical data for operator workstation equipment, interface equipment, control units, transducers/transmitters, sensors, actuators, valves, relays/switches, control panels, and operator interface equipment.
 2. Control System Software: Include technical data for operating system software, operator interface, color graphics, and other third-party applications.
 3. Controlled Systems: Instrumentation list with element name, type of device, manufacturer, model number, and product data. Include written description of sequence of operation including schematic diagram.
 4. Flow Measuring Stations: Additionally include minimum placement requirements, sensor density, sensor distribution, and installed accuracy to the host control system. Devices whose accuracy is the combined accuracy of the transmitter and sensor probes shall demonstrate that the total accuracy meets the performance requirements of this specification throughout the measurement range. Submit a schedule of airflow measuring devices indicating compliance with specified accuracy at minimum and maximum airflow rates.
- B. Shop Drawings: Detail equipment assemblies and indicate dimensions, weights, loads, required clearances, method of field assembly, components, and location and size of each field connection.
1. Bill of materials of equipment indicating quantity, manufacturer, and model number.
 2. Schematic flow diagrams showing fans, pumps, coils, dampers, valves, and control devices.
 3. Wiring Diagrams: Power, signal, and control wiring.
 4. Details of control panel faces, including controls, instruments, and labeling.
 5. Written description of sequence of operation.
 6. Schedule of dampers including size, leakage, and flow characteristics.
 7. Schedule of valves including flow characteristics.
 8. DDC System Hardware:
 - a. Wiring diagrams for control units with termination numbers.
 - b. Schematic diagrams and floor plans for field sensors and control hardware.
 - c. Schematic diagrams for control, communication, and power wiring, showing trunk data conductors and wiring between operator workstation and control unit locations.
 9. Control System Software: List of color graphics indicating monitored systems, data (connected and calculated) point addresses, output schedule, and operator notations.
 10. Controlled Systems:

- a. Schematic diagrams of each controlled system with control points labeled and control elements graphically shown, with wiring.
 - b. Scaled drawings showing mounting, routing, and wiring of elements including bases and special construction.
 - c. Written description of sequence of operation including schematic diagram.
 - 1) Within the sequence of operation, all application parameters that are to be user adjustable from an OWS shall be annotated with (adj.) after the name of the parameter. This shall include set points, reset schedule parameters, calibration offsets, timer settings, control loop parameters such as gain, integral time constant, sample rates, and differentials.
 - 2) Within the sequence of operation, all calculated values that are to be viewable at the OWS shall be annotated with ("rpt") after the name.
 - d. Points list.
 - e. Label each control device with setting or adjustable range of control.
 - f. A list of all alarm points, a description of the alarm and a description of the alarm criteria.
 - g. A list of all variables for which historical trending will be applied, the sample rates and any criteria used to start and stop the historical trending.
- C. Samples for Initial Selection: For each color required, of each type of thermostat or sensor cover with factory-applied color finishes.

1.6 INFORMATIONAL SUBMITTALS

- A. Qualification Data: For Installer and factory authorized service representative.
- B. Software Upgrade Kit: For Owner to use in modifying software to suit future systems revisions or monitoring and control revisions.
- C. Field quality-control reports.

1.7 CLOSEOUT SUBMITTALS

- A. Operation and Maintenance Data: For HVAC instrumentation and control system to include in emergency, operation, and maintenance manuals. In addition to items specified in Section 01 78 23 "Operation and Maintenance Data," include the following:
 1. Maintenance instructions and lists of spare parts for each type of control device. Exploded or other detailed views of all instruments, assemblies, and accessory components together with complete parts lists and ordering instruments.
 2. Interconnection wiring diagrams with identified and numbered system components and devices.
 3. Keyboard illustrations and step-by-step procedures indexed for each operator function. Although operator functions shall be self-instructional and menu-

interactive from the mouse or keyboard terminal, this manual shall be for off-line study and refresher use.

4. Inspection period, cleaning methods, cleaning materials recommended, and calibration tolerances.
5. Calibration records and list of set points.
6. Schematic diagrams, panel drawings, components parts, drawings, points list, "as-built" record drawings.
7. Programmer's manuals with graphic descriptions of all keyboard functions required for software modifications and development. This programmer's manuals shall include computer generated listings of all DDC programs.
8. User manuals for the integrated utility and application software such as spreadsheet, and word processing software.

B. Software and Firmware Operational Documentation: Include the following:

1. Software operating and upgrade manuals.
2. Program Software Backup: On a magnetic media or compact disc, complete with data files, firmware files, application files, and graphic page files.
3. Device address list.
4. Printout of software application and graphic screens.
5. Software license required by and installed for DDC workstations and control systems.

C. Project Record Documents: Record actual locations of control components, including control units, thermostats, and sensors. Revise Shop Drawings to reflect actual installation and operating sequences.

1. Back up of control programs: Provide back-up copies of the control program on CD-RW or DVD-RW.
2. Project Record Drawings: As-built versions of submittal shop drawings provided as CAD compatible files (AUTOCAD 2010 on Windows XP Professional) on CD-RW or DVD-RW and prints of each drawing on 11"x17" paper.
3. Testing and Commissioning Reports and Checklists. Completed versions of reports, checklists, and trend logs.

1.8 MATERIALS MAINTENANCE SUBMITTALS

A. Furnish extra materials described below that match products installed and that are packaged with protective covering for storage and identified with labels describing contents.

1. Replacement Materials: One replacement diaphragm or relay mechanism for each unique valve motor .
2. Maintenance Materials: One thermostat adjusting key(s).

1.9 QUALITY ASSURANCE

- A. Installer Qualifications: Automatic control system manufacturer's authorized representative who is trained and approved for installation and maintenance of system components required for this Project.
 - 1. The Installer shall have an established working relationship with the Control System Manufacturer of not less than five years.
 - 2. The Installer shall have successfully completed Control System Manufacturer's classes on the control system. The Installer shall present for review the certification of completed training, including the hours of instruction and course outlines upon request.
 - 3. The installer shall have an office within 50 miles of the project site and provide 24-hour response in the event of a customer call.
- B. The Building Management System Contractor shall be the primary manufacturer-owned branch office that is regularly engaged in the engineering, programming, installation, and service of total integrated Building Management Systems.
 - 1. Certified local technical support shall exist within 3 hours of the site.
- C. Electrical Components, Devices, and Accessories: Listed and labeled as defined in NFPA 70, Article 100, by a testing agency acceptable to authorities having jurisdiction, and marked for intended use.
- D. Comply with NFPA 90A, "Installation of Air Conditioning and Ventilation Systems."
- E. NEMA Compliance: Comply with NEMA standards pertaining to components and devices for electric control systems.
- F. All electronic equipment shall conform to the requirements of FCC regulation Part 15, Section 15 governing radio frequency electromagnetic interference and be so labeled. Wireless technology is not acceptable.
- G. Transient current shall not affect the system and also this system shall not affect the operation of other electrical or communication equipment within building complex.
- H. Bids by wholesalers, contractors, and franchised dealers or any firm whose principal business is not that of manufacturing and installing DDC systems are not acceptable except pre-approved by Owner and Engineer for this Project.
- I. Independent temperature control service by independent contractors, distributors, and franchised installers will not be acceptable except pre-approved by Owner and Engineer for this Project.
- J. All materials and equipment used shall be standard components, regularly manufactured for this and/or other systems, and shall not be custom designed especially for this project. All components shall have been thoroughly tested and proven in actual use for more than five years. Spare parts shall be available for at least five years after date of Final Completion.

- K. Codes and Standards: Meet requirements of all applicable standards and codes, except when more detailed or stringent requirements are indicated by the Contract Documents, including requirements of this Section.
1. Underwriters Laboratories: Products shall be UL-916-PAZX listed.
 2. Federal Communications Commission -- Part J.
 3. International Building Code.
 4. International Mechanical Code.
 5. International Energy Conservation Code.
 6. National Electrical Code.
 7. ANSI/ASHRAE/IESNA 90.1-2010 with current addenda and annexes-Mandatory Provisions, Energy Standard for Buildings Except Low-Rise Residential Buildings.
 8. ANSI/ASHRAE 135 with current addenda and annexes, A Data Communication Protocol for Building Automation and Control Networks (BACnet).

1.10 DELIVERY, STORAGE, AND HANDLING

- A. Factory-Mounted Components: Where control devices specified in this Section are indicated to be factory mounted on equipment, arrange for shipping of control devices to equipment manufacturer.
- B. System Software: Update to latest version of software at Project completion.

1.11 COORDINATION

- A. Coordinate location of thermostats, humidistats, and other exposed control sensors with plans and room details before installation.
- B. Coordinate supply of conditioned electrical branch circuits for control units and operator workstation.
- C. Coordinate equipment with Section 26 29 13 "Enclosed Controllers " to achieve compatibility with motor starters and annunciation devices.
- D. Coordinate equipment with existing Variable Frequency Motor-Controllers to achieve compatibility with variable frequency controllers, interface requirements, and annunciation devices.
- E. Test and Balance Coordination:
1. Provide Test and Balance Contractor a single set of necessary tools to interface to control system for testing and balancing.
 2. Train Test and Balance Contractor to use control system interface tools.
 3. Provide a qualified technician to assist with testing and balancing.
 4. Test and Balance Contractor shall return tools undamaged and in working condition at completion of testing and balancing.

- F. Coordination with Other Controls: Integrate with and coordinate controls and control devices furnished or installed by others as follows:
1. Communication media and equipment shall be provided as specified.
 2. Each supplier of a controls product shall configure, program, start up, and test that product to meet the sequences of operation described regardless of where within the Contract Documents those products are described.
 3. Coordinate and resolve incompatibility issues that arise between control products provided under this section and those provided under other Sections or Divisions of this specification.
 4. Controls Installer shall be responsible for integration of control products provided by multiple suppliers regardless of where integration is described within the Contract Documents.

1.12 WARRANTY

- A. Special Warranty: Manufacturer and Installer agree to adjust, repair or replace, service components of BMS that fail(s) in materials or workmanship within specified warranty period. Respond to the Owner's request for warranty service within 24 hours during customary business hours.
1. Warranty Period: Two year(s) from date of Substantial Completion.

1.13 OWNERSHIP OF PROPRIETARY MATERIAL

- A. The Owner shall retain all rights to software for this project.
- B. The Owner will sign a copy of the manufacturer's standard software and firmware licensing agreement as a condition of this contract. Such license shall grant use of all programs and application software to Owner as defined by the manufacturer's license agreement, but shall protect manufacturer's rights to disclosure of Trade Secrets contained within such software.
- C. The licensing agreement shall not preclude the use of the software by individuals under contract to the Owner for commissioning, servicing, or altering the system in the future. Use of the software by individuals under contract to the owner shall be restricted to use on the Owner's computers and only for the purpose of commissioning, servicing, or altering the installed system.
- D. All project developed software, files and documentation shall become the property of the Owner. These include but are not limited to:
1. Server, workstation, application-level software
 2. Application programming tools
 3. Configuration tools
 4. Network diagnostic tools
 5. Addressing tools
 6. Application files

7. Configuration files
 8. Graphic files
 9. Report files
 10. Graphic symbol libraries
 11. All documentation and data files
- E. Any and all required IDs and passwords for access to any component or software program shall be provided to the Owner. The Owner shall determine which organizations to be named in the SI organization ID (“orgid”) of all software licenses. Owner shall be free to direct the modification of the “orgid” in any software license, regardless of supplier, manufacturer.

PART 2 - PRODUCTS

2.1 MANUFACTURERS

- A. In other Part 2 articles where titles below introduce lists, the following requirements apply to product selection:
1. Manufacturers: Subject to compliance with requirements, provide products by one of the manufacturers specified.

2.2 CONTROL SYSTEM

- A. Manufacturers:
1. Johnson Controls, Inc. (Metasys)
 2. No Substitution.
- B. Control system shall consist of sensors, indicators, actuators, final control elements, interface equipment, other apparatus, accessories, and software connected to distributed controllers operating in multiuser, multitasking environment on token-passing network and programmed to control mechanical systems. An operator workstation permits interface with the network via dynamic color graphics with each mechanical system, building floor plan, and control device depicted by point-and-click graphics.
- C. Control System shall be a complete system designed for use with the enterprise IT systems. This functionality shall extend into the equipment rooms. Devices residing on the automation network located in equipment rooms and similar shall be fully IT compatible devices that mount and communicate directly on the IT infrastructure in the facility. Contractor shall be responsible for coordination with the owner’s IT staff to ensure that the BMS will perform in the owner’s environment without disruption to any of the other activities taking place on that LAN.
- D. The work of the single DDC/BMS Contractor shall be as defined individually and collectively in all Sections of Division 23 specification together with the associated

Point Lists and Drawings and the associated interfacing work as referenced in the related documents.

- E. The BMS work shall consist of the provision of all labor, materials, tools, equipment, software, software licenses, software configurations and database entries, interfaces, wiring, tubing, installation, labeling, engineering, calibration, documentation, samples, submittals, testing, commissioning, training services, permits and licenses, transportation, shipping, handling, administration, supervision, management, insurance, temporary protection, cleaning, cutting and patching, warranties, services, and items, even though these may not be specifically mentioned in these Division documents which are required for the complete, fully functional and commissioned BMS.
1. The omission of hardware, firmware, and software components required to satisfy the specified configuration(s), but not specified due to the esoteric requirements of a particular manufacturer's product design shall not relieve the Installer from the responsibilities of providing and installing omitted apparatuses, (i.e. feed-back circuits, calibration resistors, and override detection interface devices).
- F. The BMS as provided shall incorporate, at minimum, the following integrated features, functions and services:
1. Operator information, alarm management and control functions.
 2. Enterprise-level information and control access.
 3. Information management including monitoring, transmission, archiving, retrieval, and reporting functions.
 4. Diagnostic monitoring and reporting of BMS functions.
 5. Offsite monitoring and management access.
 6. Energy management
 7. Standard applications for terminal HVAC systems.
 8. Indoor Air Quality monitoring and control.
- G. The Building Management System (BMS) shall use an open architecture and fully support a multi-vendor environment. To accomplish this effectively, the BMS shall support open communication protocol standards and integrate a wide variety of third-party devices and applications. The system shall be designed for use on the Internet, or intranets using off the shelf, industry standard technology compatible with other owner provided networks.
- H. The Building Management System shall consist of the following:
1. Standalone Network Automation Engine(s).
 2. Field Equipment Controller(s).
 3. Input/Output Module(s).
 4. Local Display Device(s).
 5. Distributed User Interface(s).
 6. Network processing, data storage and communications equipment.
 7. Other components required for a complete and working BMS.

- I. The system shall be modular in nature, and shall permit expansion of both capacity and functionality through the addition of sensors, actuators, controllers, and operator devices, while re-using existing controls equipment.
- J. System architectural design shall eliminate dependence upon any single device for alarm reporting and control execution.
 - 1. The failure of any single component or network connection shall not interrupt the execution of control strategies at other operational devices.
 - 2. The System shall maintain all settings and overrides through a system reboot.
- K. System architectural design shall eliminate dependence upon any single device for alarm reporting and control execution.

2.3 BMS ARCHITECTURE

A. Automation Network

- 1. The automation network shall be based on a PC industry standard of Ethernet TCP/IP. Where used, LAN controller cards shall be standard "off the shelf" products available through normal PC vendor channels.
- 2. The BMS shall network multiple user interface clients, automation engines, system controllers, and application-specific controllers. Provide application and data server(s) as required for systems operation.
- 3. All BMS devices on the automation network shall be capable of operating at a communication speed of 100 Mbps, with full peer-to-peer network communication.
- 4. Network Automation Engines (NAE) shall reside on the automation network.
- 5. The automation network will be compatible with other enterprise-wide networks. Where indicated, the automation network shall be connected to the enterprise network and share resources with it by way of standard networking devices and practices.

B. Control Network

- 1. Network Automation Engines (NAE) shall provide supervisory control over the control network and shall support all three (3) of the following communication protocols:
 - a. BACnet Standard MS/TP Bus Protocol ASHRAE SSPC-135, Clause 9
 - 1) The NAE shall be BACnet Testing Labs (BTL) certified and carry the BTL Label.
 - 2) The NAE shall be tested and certified as a BACnet Building Controller (B-BC).
 - b. LonWorks enabled devices using the Free Topology Transceiver (FTT-10a).
 - c. The Johnson Controls N2 Field Bus.

2. Control networks shall provide either "Peer-to-Peer," Master-Slave, or Supervised Token Passing communications, and shall operate at a minimum communication speed of 9600 baud.
3. DDC Controllers shall reside on the control network.
4. Control network communication protocol shall be BACnet Standard MS/TP Bus Protocol ASHRAE SSPC-135.
5. A BACnet Protocol Implementation Conformance Statement (PICS) shall be provided for each controller device (master or slave) that will communicate on the BACnet MS/TP Bus.

C. Integration

1. Hardwired

- a. Analog and digital signal values shall be passed from one system to another via hardwired connections.
- b. There will be one separate physical point on each system for each point to be integrated between the systems.

2. Direct Protocol (Integrator Panel)

- a. The BMS system shall include appropriate hardware equipment and software to allow bi-directional data communications between the BMS system and 3rd party manufacturers' control panels. The BMS shall receive, react to, and return information from multiple building systems, including but not limited to the chillers, boilers, variable frequency drives, power monitoring system, and medical gas.
- b. All data required by the application shall be mapped into the Automation Engine's database, and shall be transparent to the operator.
- c. Point inputs and outputs from the third-party controllers shall have real-time interoperability with BMS software features such as: Control Software, Energy Management, Custom Process Programming, Alarm Management, Historical Data and Trend Analysis, Totalization, and Local Area Network Communications.

3. BACnet Protocol Integration - BACnet

- a. The neutral protocol used between systems will be BACnet over Ethernet and comply with the ASHRAE BACnet standard 135.
- b. A complete Protocol Implementation Conformance Statement (PICS) shall be provided for all BACnet system devices.
- c. The ability to command, share point object data, change of state (COS) data and schedules between the host and BACnet systems shall be provided.

2.4 USER INTERFACE

A. Dedicated Web Based User Interface

1. Furnish and install a personal computer for command entry, information management, network alarm management, and database management functions. All real-time control functions, including scheduling, history collection and alarming, shall be resident in the BMS Network Automation Engines to facilitate greater fault tolerance and reliability.
 2. Dedicated User Interface Architecture – The architecture of the computer shall be implemented to conform to industry standards, so that it can accommodate applications provided by the BMS Contractor and by other third party applications suppliers, including but not limited to Microsoft Office Applications. Specifically it must be implemented to conform to the following interface standards.
 - a. Microsoft Internet Explorer for user interface functions
 - b. Microsoft Office Professional for creation, modification and maintenance of reports, sequences other necessary building management functions
 - c. Microsoft Outlook or other e-mail program for supplemental alarm functionality and communication of system events, and reports
 - d. Required network operating system for exchange of data and network functions such as printing of reports, trends and specific system summaries
 - e. PC Hardware – Use existing operator workstation or web server available at the Owner's Facility. Provide additional hardware (hard drive, communication ports, video drivers, network interface cards, and cabling.) to facilitate all control functions and software requirements specified for the DDC system.
 3. Operating System Software
 - a. Windows XP Professional or Windows 7 (32 bit)
 - b. Where user interface is not provided via browser, provide complete operator workstation software package, including any hardware or software keys. Include the original installation disks and licenses for all included software, device drivers, and peripherals.
 - c. Provide software registration cards to the Owner for all included software.
 4. Peripheral Hardware
 - a. Reports printer: Use existing.
- B. Site Management User Interface Application Components
1. Operator Interface
 - a. An integrated browser based client application shall be used as the user operator interface program.
 - b. The System shall employ an event-driven rather than a device polling methodology to dynamically capture and present new data to the user.
 - c. All Inputs, Outputs, Setpoints, and all other parameters as defined within Part 3, shown on the design drawings, or required as part of the system software, shall be displayed for operator viewing and modification from the operator interface software.

- d. The user interface software shall provide help menus and instructions for each operation and/or application.
 - e. The system shall support customization of the UI configuration and a home page display for each operator.
 - f. The system shall support user preferences in the following screen presentations:
 - 1) Alarm
 - 2) Trend
 - 3) Display
 - 4) Applications
 - g. All controller software operating parameters shall be displayed for the operator to view/modify from the user interface. These include: setpoints, alarm limits, time delays, PID tuning constants, run-times, point statistics, schedules, and so forth.
 - h. The Operator Interface shall incorporate comprehensive support for functions including, but not necessarily limited to, the following:
 - 1) User access for selective information retrieval and control command execution
 - 2) Monitoring and reporting
 - 3) Alarm, non-normal, and return to normal condition annunciation
 - 4) Selective operator override and other control actions
 - 5) Information archiving, manipulation, formatting, display and reporting
 - 6) BMS internal performance supervision and diagnostics
 - 7) On-line access to user HELP menus
 - 8) On-line access to current BMS as-built records and documentation
 - 9) Means for the controlled re-programming, re-configuration of BMS operation and for the manipulation of BMS database information in compliance with the prevailing codes, approvals and regulations for individual BMS applications
 - i. The system shall support a list of application programs configured by the users that are called up by the following means:
 - 1) The Tools Menu
 - 2) Hyperlinks within the graphics displays
 - 3) Key sequences
 - j. The operation of the control system shall be independent of the user interface, which shall be used for operator communications only. Systems that rely on an operator workstation to provide supervisory control over controller execution of the sequences of operations or system communications shall not be acceptable.
2. Navigation Trees
- a. The system will have the capability to display multiple navigation trees that will aid the operator in navigating throughout all systems and points

connected. At minimum provide a tree that identifies all systems on the networks.

- b. Provide the ability for the operator to add custom trees. The operator will be able to define any logical grouping of systems or points and arrange them on the tree in any order. It shall be possible to nest groups within other groups. Provide at minimum 5 levels of nesting.
- c. The navigation trees shall be “dockable” to other displays in the user interface such as graphics. This means that the trees will appear as part of the display, but can be detached and then minimized to the Windows task bar. A simple keystroke will reattach the navigation to the primary display of the user interface.

3. Alarms

- a. Alarms shall be routed directly from Network Automation Engines to PCs and servers. It shall be possible for specific alarms from specific points to be routed to specific PCs and servers. The alarm management portion of the user interface shall, at the minimum, provide the following functions:
 - 1) Log date and time of alarm occurrence.
 - 2) Generate a “Pop-Up” window, with audible alarm, informing a user that an alarm has been received.
 - 3) Allow a user, with the appropriate security level, to acknowledge, temporarily silence, or discard an alarm.
 - 4) Provide an audit trail on hard drive for alarms by recording user acknowledgment, deletion, or disabling of an alarm. The audit trail shall include the name of the user, the alarm, the action taken on the alarm, and a time/date stamp.
 - 5) Provide the ability to direct alarms to an e-mail address or alphanumeric pager. This must be provided in addition to the pop up window described above. Systems that use e-mail and pagers as the exclusive means of annunciating alarms are not acceptable.
 - 6) Any attribute of any object in the system may be designated to report an alarm.
- b. The BMS shall annunciate diagnostic alarms indicating system failures and non-normal operating conditions.
- c. The BMS shall allow a minimum of 4 categories of alarm sounds customizable through user defined wav files.
- d. The BMS shall annunciate application alarms at minimum, as required by Part 3.

4. Reports and Summaries

- a. Reports and Summaries shall be generated and directed to the user interface displays, with subsequent assignment to printers, or disk. As a minimum, the system shall provide the following reports:
 - 1) All points in the BMS
 - 2) All points in each BMS application

- 3) All points in a specific controller
 - 4) All points in a user-defined group of points
 - 5) All points currently in alarm
 - 6) All points locked out
 - 7) All user defined and adjustable variables, schedules, interlocks and the like.
- b. Summaries and Reports shall be accessible via standard UI functions and not dependent upon custom programming or user defined HTML pages.
 - c. Selection of a single menu item, tool bar item, or tool bar button shall print any displayed report or summary on the system printer for use as a building management and diagnostics tool.
 - d. Provide the capability to view, command, and modify large quantities of similar data in tailored summaries created online without the use of a secondary application like a spreadsheet. Summary definition shall allow up to seven user defined columns describing attributes to be displayed including custom column labels. Up to 100 rows per summary shall be supported. Summary viewing shall be available over the network using a standard Web browser.
5. Schedules
- a. A graphical display for time-of-day scheduling and override scheduling of building operations shall be provided. At a minimum, the following functions shall be provided:
 - 1) Weekly schedules
 - 2) Exception Schedules
 - 3) Monthly calendars
 - b. Weekly schedules shall be provided for each group of equipment with a specific time use schedule.
 - c. It shall be possible to define one or more exception schedules for each schedule including references to calendars
 - d. Monthly calendars shall be provided that allow for simplified scheduling of holidays and special days for a minimum of five years in advance. Holidays and special days shall be user-selected with the pointing device or keyboard, and shall automatically reschedule equipment operation as previously defined on the exception schedules.
 - e. Changes to schedules made from the User Interface shall directly modify the Network Automation Engine schedule database.
 - f. Schedules and Calendars shall comply with ASHRAE Standard 135 BACnet Standard.
 - g. Selection of a single menu item or tool bar button shall print any displayed schedule on the system printer for use as a building management and diagnostics tool.
 - h. Software shall be provided to configure and implement optimal start and stop programming based on existing indoor and outdoor environmental conditions as well as equipment operating history.

6. Password

- a. Multiple-level password access protection shall be provided to allow the user/manager to user interface control, display, and database manipulation capabilities deemed appropriate for each user, based on an assigned password.
- b. Each user shall have the following: a user name (accept 24 characters minimum), a password (accept 12 characters minimum), and access levels.
- c. The system shall allow each user to change his or her password at will.
- d. When entering or editing passwords, the system shall not echo the actual characters for display on the monitor.
- e. A minimum of six levels of access shall be supported individually or in any combination as follows:
 - 1) Level 1 = View Data
 - 2) Level 2 = Command
 - 3) Level 3 = Operator Overrides
 - 4) Level 4 = Database Modification
 - 5) Level 5 = Database Configuration
 - 6) Level 6 = All privileges, including Password Add/Modify
- f. A minimum of 100 unique passwords shall be supported.
- g. Operators shall be able to perform only those commands available for their respective passwords. Display of menu selections shall be limited to only those items defined for the access level of the password used to log-on.
- h. Operators shall be further limited to only access, command, and modify those buildings, systems, and subsystems for which they have responsibility. Provide a minimum of 100 categories of systems to which individual operators may be assigned.
- i. The system shall automatically generate a report of log-on/log-off and system activity for each user. Any action that results in a change in the operation or configuration of the control system shall be recorded, including: modification of point values, schedules or history collection parameters, and all changes to the alarm management system, including the acknowledgment and deletion of alarms.

7. Screen Manager

- a. The User Interface shall be provided with screen management capabilities that allow the user to activate, close, and simultaneously manipulate a minimum of 4 active display windows plus a network or user defined navigation tree.

8. Dynamic Color Graphics

- a. The graphics application program shall be supplied as an integral part of the User Interface. Browser or Workstation applications that rely only upon HTML pages shall not be acceptable.
- b. The graphics applications shall include a create/edit function and a runtime function. The system architecture shall support an unlimited number of

graphics documents (graphic definition files) to be generated and executed. The graphics shall be able to display and provide animation based on real-time data that is acquired, derived, or entered.

- c. Graphics runtime functions – A maximum of 16 graphic applications shall be able to execute at any one time on a user interface or workstation with 4 visible to the user. Each graphic application shall be capable of the following functions:
 - 1) All graphics shall be fully scalable
 - 2) The graphics shall support a maintained aspect ratio.
 - 3) Multiple fonts shall be supported.
 - 4) Unique background shall be assignable on a per graphic basis.
 - 5) The color of all animations and values on displays shall indicate the status of the object attribute.
 - 6) Graphics that represent buildings or systems shall allow natural links and transitions between related detailed tabular views of data that compliment the graphic.
- d. Operation from graphics – It shall be possible to change values (setpoints) and states in system controlled equipment directly from the graphic.
- e. Floor Plan graphics – The user interface shall provide graphic applications that summarize conditions on a floor. Floor plan graphics shall indicate thermal comfort using dynamic colors to represent zone temperature deviations from zone setpoint(s). Floor plan graphics shall display overall metrics for each zone in the floor.
- f. Aliasing – Many graphic displays representing part of a building and various building components are exact duplicates, with the exception that the various variables are bound to different field values. Consequently, it shall be possible to bind the value of a graphic display to aliases, as opposed to the physical field tags.
- g. Graphic editing tool – A graphic editing tool shall be provided that allows for the creation and editing of graphic files. The graphic editor shall be capable of performing/defining all animations, and defining all runtime binding.
 - 1) The graphic editing tool shall provide a library of standard HVAC equipment, floor plan, lighting, security, and network symbols.
 - 2) The graphic editing tool shall provide for the creation and positioning of library symbols by dragging from tool bars or drop-downs and positioning where required.
 - 3) The graphics editing tool shall permit the importing of AutoCAD drawings for use in the system.
 - 4) The graphic editing tool shall be able to add additional content to any graphic by importing images in the SVG, PNG, or JPG file formats.

9. Historical Trending and Data Collection

- a. Each Automation Engine shall store trend and point history data for all analog and digital inputs and outputs, as follows:

- 1) Any point, physical or calculated, may be designated for trending. Two methods of collection shall be allowed:
 - a) Defined time interval
 - b) Upon a change of value
 - 2) Each Automation Engine shall have the capability to store multiple samples for each physical point and software variable based upon available memory, including an individual sample time/date stamp. Points may be assigned to multiple history trends with different collection parameters.
- b. Trend and change of value data shall be stored within the engine and uploaded to a dedicated trend database or exported in a selectable data format via a provided data export utility. Uploads to a dedicated database shall occur based upon one of the following: user-defined interval, manual command, or when the trend buffers are full. Exports shall be as requested by the user or on a time scheduled basis.
 - c. The system shall provide a configurable data storage subsystem for the collection of historical data. Data can be stored in SQL database format.
10. Trend Data Viewing and Analysis
- a. Provide a trend viewing utility that shall have access to all database points.
 - b. It shall be possible to retrieve any historical database point for use in displays and reports by specifying the point name and associated trend name.
 - c. The trend viewing utility shall have the capability to define trend study displays to include multiple trends
 - d. Displays shall be able to be single or stacked graphs with on-line selectable display characteristics, such as ranging, color, and plot style.
 - e. Display magnitude and units shall both be selectable by the operator at any time without reconfiguring the processing or collection of data. This is a zoom capability.
 - f. Display magnitude shall automatically be scaled to show full graphic resolution of the data being displayed.
 - g. The Display shall support the user's ability to change colors, sample sizes, and types of markers.
11. Database Management
- a. Where a separate SQL database is utilized for information storage the System shall provide a Database Manager that separates the database monitoring and managing functions by supporting two separate windows.
 - b. Database secure access shall be accomplished using standard SQL authentication including the ability to access data for use outside of the Building Automation application.
 - c. The database managing function shall include summarized information on trend, alarm, event, and audit for the following database management actions:

- 1) Backup
 - 2) Purge
 - 3) Restore
- d. The Database Manager shall support four tabs:
- 1) Statistics – shall display Database Server information and Trend, Alarm (Event), and Audit information on the Metasys Databases.
 - 2) Maintenance – shall provide an easy method of purging records from the Metasys Server trend, alarm (event), and audit databases by supporting separate screens for creating a backup prior to purging, selecting the database, and allowing for the retention of a selected number of day's data.
 - 3) Backup – Shall provide the means to create a database backup file and select a storage location.
 - 4) Restore – shall provide a restricted means of restoring a database by requiring the user to log into an Expert Mode in order to view the Restore screen.
- e. The Status Bar shall appear at the bottom of all Metasys Database Manager Tabs and shall provide information on the current database activity. The following icons shall be provided:
- 1) Ready
 - 2) Purging Record from a database
 - 3) Action Failed
 - 4) Refreshing Statistics
 - 5) Restoring database
 - 6) Shrinking a database
 - 7) Backing up a database
 - 8) Resetting internet information Services
 - 9) Starting the Metasys Device Manager
 - 10) Shutting down the Metasys Device Manager
 - 11) Action successful
- f. The Database Manager monitoring functions shall be accessed through the Monitoring Settings window and shall continuously read database information once the user has logged in.
- g. The System shall provide user notification via taskbar icons and e-mail messages when a database value has exceeded a warning or alarm limit.
- h. The Monitoring Settings window shall have the following sections:
- 1) General – Shall allow the user to set and review scan intervals and start times.
 - 2) Email – Shall allow the user to create and review e-mail and phone text messages to be delivered when a Warning or Alarm is generated.
 - 3) Warning – shall allow the user to define the Warning limit parameters, set the Reminder Frequency, and link the e-mail message.

- 4) Alarm – shall allow the user to define the Alarm limit parameters, set the Reminder Frequency, and link the e-mail message.
 - 5) Database login – Shall protect the system from unauthorized database manipulation by creating a Read Access and a Write Access for each of the Trend, Alarm (Event) and Audit databases as well as an Expert Mode required to restore a database.
- i. The Monitoring Settings Taskbar shall provide the following informational icons:
 - 1) Normal – Indicates by color and size that all databases are within their limits.
 - 2) Warning - Indicates by color and size that one or more databases have exceeded their Warning limit.
 - 3) Alarm - Indicates by color and size that one or more databases have exceeded their Alarm limit.
 - j. The System shall provide user notification via Taskbar icons and e-mail messages when a database value has exceeded a warning or alarm limit.

C. Ready Access Portal User Interface

1. BMS Contractor shall provide and install all computer hardware and software required for the purpose of configuration and consolidation of information and programs required for the delivery of a Task Focused, Web Based Portal to the BMS. This Ready Access Portal shall provide a natural, complementary extension to the Metasys site management user interface previously described.
2. Ready Access Portal Architecture – The architecture of the system shall be implemented to conform to industry standards, so that it can accommodate the required applications provided by the BMS Contractor as well as communicate information too and from the Metasys system Site Director.
3. User Interface Application Components
 - a. The ready access portal shall provide an intuitive user interface to key Metasys functions and tasks via web browser.
 - b. Plug-ins or special software shall not be required for access to alarm, summary, schedule and trend data.
 - c. The portal shall include the ability to view full graphical representations of systems and equipment on PC platforms
 - d. The control system shall provide Secure Sockets Level (SSL) and Active Directory service support. If the Active Directory service and Single Sign-On features are enabled and the user is logged in to the Windows desktop, the login screen does not appear and access to the system is automatic.
 - e. Provide a common tool for graphics creation, schedule creation, custom programming, user access and hardware definition
 - f. Information shall be accessible on both personal computer and handheld device platforms as follows:
 - 1) Personal computers – Internet Explorer Version 7.0 recommended

- 2) Handheld devices – Internet Explorer for Window Mobile Version 5.0 or 6.0 recommended, as well as Apple i-Phone, i-Touch, or i-Pad. UI is optimized for devices with a 240 x 320 pixel screen size (QVGA).

4. Operator Interface

- a. Password access shall be as described previously for management portal UI.
- b. Once logged in, the System shall display a pre-selected screen tailored to the task requirements of the individual user.
- c. The User Interface shall utilize an intuitive navigation and display method designed for operators who access the system for casual information and control or on an infrequent basis. It shall feature three basic components.
 - 1) Radio buttons for selection of the type of information to be displayed including Alerts, Summary, Schedules and Diagnostics
 - 2) Navigation tree for selection of the specific data to be displayed on screen for the selected type. The navigation tree may be hidden and expanded by the operator to optimize the display of information
 - 3) A display window that provides the selected information by type in a pre-configured tabular format
- d. The user interface software shall provide help menus and instructions for each operation and/or application.
- e. The system shall provide support for up to 100 concurrent users from an unlimited universe individuals with defined password access to the system
- f. The system shall utilize Secure Sockets Level (SSL) support as required to allow the ready access portal to communicate across a network in a way designed to prevent eavesdropping, tampering, and message forgery. It provides endpoint authentication and communications privacy over the network using cryptography
- g. The system shall have the capability to display multiple navigation trees that correspond to the user views configured in the management portal UI.
- h. The alert summary of the ready access portal shall, at the minimum, provide the following information
 - 1) Alert (Alarm) type
 - 2) Date and time of alert occurrence
 - 3) Priority (color coded to level)
 - 4) Item name.
 - 5) Item value (if applicable)
 - 6) Message
 - 7) Any attribute of any object in the system may be designated to report an alarm
- i. A standard summary on the ready access portal shall, at the minimum, provide the following information
 - 1) Point type graphic icon
 - 2) Item name

- 3) Item value
 - 4) Item status
 - 5) Access to the Change Value window (if applicable) for the purpose of setting, holding or releasing an item value
- j. A custom summary on the ready access portal shall display user-specified summaries of key data sets that can be quickly filtered and sorted. Items within these custom summaries can be commanded.
- k. A graphic view on the ready access portal shall display as described previously for management portal UI.
- l. The schedule detail summary of the ready access portal shall, at the minimum, provide the following information
- 1) Scheduled occurrences including time and value
 - 2) Scheduled overrides including start time, end time and value
 - 3) A list of all scheduled items including name and attribute, value, status and priority
 - 4) Access to the Add Temporary Override window for the purpose of adding a temporary override to the schedule
- m. The diagnostic (trend) summary of the ready access portal as viewed on a personal computing device shall provide the following information.
- 1) Item name
 - 2) Item status
 - 3) Trend name
 - 4) Trend status
 - 5) Full path name
 - 6) Access to trend detail summary including trended value, time and date arranged in a user selectable format of 1 hour, 12 hours, 24 hours, 48 hours, or 72 hours.

2.5 NETWORK AUTOMATION ENGINE (NAE)

- A. Existing NAE shall be reused and upgraded to suit new HVAC systems.

2.6 NETWORK CONTROL ENGINE (NCE 25xx)

- A. The Network Control Engine (NCE) shall be a fully user-programmable, supervisory controller. The NCE shall monitor the network of distributed application-specific controllers, provide global strategy and direction, and communicate on a peer-to-peer basis with other Network Automation Engines.
- B. The Network Control Engine (NCE) shall be a fully user-programmable, digital controller that includes a minimum of 33 I/O points.
- C. Automation Network: The NCE shall reside on the automation network and shall support a subnet of 32 Field controllers.

- D. User Interface: Each NCE shall have the ability to deliver a web based User Interface (UI) as previously described. All computers connected physically or virtually to the automation network shall have access to the web based UI.
1. The web based UI software shall be imbedded in the NCE. Systems that require a local copy of the system database on the user's personal computer are not acceptable.
 2. The NCE shall support a minimum of two (2) concurrent users.
 3. The NCE shall have the capability of generating web based UI graphics. The graphics capability shall be imbedded in the NCE.
 4. Systems that support UI Graphics from a central database or require the graphics to reside on the user's personal computer are not acceptable.
 5. The web based UI shall support the following functions using a standard version of Microsoft Internet Explorer:
 - a. Configuration
 - b. Commissioning
 - c. Data Archiving
 - d. Monitoring
 - e. Commanding
 - f. System Diagnostics
 6. Systems that require workstation software or modified web browsers are not acceptable.
 7. The NCE shall allow temporary use of portable devices without interrupting the normal operation of permanently connected modems.
- E. The NCE shall employ a finite state control engine to eliminate unnecessary conflicts between control functions at crossover points in their operational sequences. Suppliers using non-state based DDC shall provide separate control strategy diagrams for all controlled functions in their submittals.
- F. The NCE shall be factory programmed with a continuous adaptive tuning algorithm that senses changes in the physical environment and continually adjusts loop tuning parameters appropriately. Controllers that require manual tuning of loops or perform automatic tuning on command only, shall not be acceptable.
- G. The NCE shall be assembled in a plenum-rated plastic housing with flammability rated to UL94-5VB.
- H. The NCE shall support the following number and types of inputs and outputs:
1. Ten Universal Inputs - shall be configured to monitor any of the following:
 - a. Analog Input, Voltage Mode
 - b. Analog Input, Current Mode
 - c. Analog Input, Resistive Mode
 - d. Binary Input, Dry Contact Maintained Mode
 - e. Binary Input, Pulse Counter Mode

2. Eight Binary Inputs - shall be configured to monitor either of the following:
 - a. Dry Contact Maintained Mode
 - b. Pulse Counter Mode
3. Four Analog Outputs - shall be configured to output either of the following
 - a. Analog Output, Voltage Mode
 - b. Analog Output, Current Mode
4. Seven Binary Outputs - shall output the following:
 - a. 24 VAC Triac
5. Four Configurable Outputs - shall be configured to output either of the following:
 - a. Analog Output, Voltage Mode
 - b. Binary Output, 24 VAC Triac Mode
- I. The NCE shall have the ability to monitor and control a network of sensors and actuators over a Sensor-Actuator Bus (SA Bus).
 1. The SA Bus shall be a Master-Slave/Token-Passing (MS/TP) Bus supporting BACnet Standard protocol SSPC-135, Clause 9.
 2. The SA Bus shall support a minimum of 10 devices.
 3. The SA Bus shall operate at a maximum distance of 1,200 Ft. between the NCE and the furthest connected device.
- J. The NCE shall have the capability to execute complex control sequences involving direct wired I/O points as well as input and output devices communicating over the Field Trunk or the SA Bus.
- K. The NCE shall support, but not be limited to, the following applications:
 1. Central Equipment including chillers and boilers
 2. Lighting and electrical distribution
 3. Built-up air handling units for special applications
 4. Power generation and energy monitoring equipment
 5. Interfaces to security and fire detection systems
- L. The NCE shall be microprocessor-based with a minimum word size of 32 bits. The NAE shall be a multi-tasking, multi-user, and real-time digital control processor. Standard operating systems shall be employed. NCE size and capability shall be sufficient to fully meet the requirements of this Specification.
- M. The NCE shall employ an industrial single board computer.
- N. Each NCE shall have sufficient memory to support its own operating system, databases, and control programs, and to provide supervisory control for all control level devices.

- O. The NCE shall include an integrated, hardware-based, real-time clock.
- P. The NCE shall employ nonvolatile Flash memory to store all programs and data. The NCE shall employ a data protection battery to save data and power the real time clock when primary power is interrupted.
- Q. The NCE shall provide removable, color coded, screw terminal blocks for 24 VAC power, communication bus and I/O point field wiring.
- R. The NCE shall include troubleshooting LED indicators to identify the following conditions:
 - 1. Power
 - 2. Fault
 - 3. SA Bus
 - 4. FC Bus
 - 5. Battery Fault
 - 6. Ethernet
 - 7. 10 LNK
 - 8. 100 LNK
 - 9. Run
 - 10. Peer Com
- S. Communications Ports – The NCE shall provide the following ports for operation of operator Input/Output (I/O) devices, such as industry-standard computers, modems, and portable operator's terminals.
 - 1. USB port
 - 2. RS-232 serial data communication port
 - 3. RS-485 port
 - 4. RJ-45 Ethernet port
 - 5. RJ-12 jack
- T. The NCE shall support an internal modem with RJ-12 6-pin telephone line connector.
- U. Diagnostics: The NCE shall continuously perform self-diagnostics, communication diagnosis, and diagnosis of all panel components. The Network Control Engine shall provide both local and remote annunciation of any detected component failures, low battery conditions, or repeated failures to establish communication.
- V. Power Failure: In the event of the loss of normal power, The NCE shall continue to operate for a user adjustable period of up to 10 minutes after which there shall be an orderly shutdown of all programs to prevent the loss of database or operating system software.
 - 1. During a loss of normal power, the control sequences shall go to the normal system shutdown conditions. All critical configuration data shall be saved into Flash memory.

2. Upon restoration of normal power and after a minimum off-time delay, the controller shall automatically resume full operation without manual intervention through a normal soft-start sequence.
- W. Certification: The NCE shall be listed by Underwriters Laboratories (UL). File E107041, CCN PAZX, UL 916, Energy Management Equipment. FCC Compliant to CFR47, Part 15, Subpart B, Class A
- X. Field Controller Bus: The NCE shall support the following communication protocols on the Field Controller Bus:
1. The NCE shall support BACnet Standard MS/TP Bus Protocol ASHRAE SSPC-135, Clause 9 on the controller network.
 - a. The NCE shall be BACnet Testing Labs (BTL) certified and carry the BTL Label.
 - b. The NAE shall be tested and certified as a BACnet Building Controller (B-BC).
 - c. A BACnet Protocol Implementation Conformance Statement shall be provided for the NCE.
 - d. The Conformance Statements shall be submitted 10 days prior to bidding.
 - e. The NCE shall support a minimum of 32 control devices.
 2. The NCE shall support LonWorks enabled devices using the Free Topology Transceiver FTT10 on the Field Controller Bus (LonWorks Network).
 - a. All LonWorks controls devices shall be LonMark certified.
 - b. The NCE shall support a minimum of 32 LonWorks enabled control devices.
 3. The NCE shall support the N2 devices on the Field Controller Bus (Johnson Controls N2 Bus).
 - a. The NCE shall support a minimum of 32 N2 control devices.
 - b. The Bus shall conform to Electronic Industry Alliance (EIA) Standard RS-485.
 - c. The Bus shall employ a master/slave protocol where the NCE is the master.
 - d. The Bus shall employ a four (4) level priority system for polling frequency.
 - e. The Bus shall be optically isolated from the NCE.
 - f. The Bus shall support the Metasys Integrator System.

2.7 DDC EQUIPMENT

- A. Operator Workstation: Update Existing Workstation located at the facility.
- B. Diagnostic Terminal Unit: Update Existing Workstation located at the facility.
- C. Field Equipment Controller (FEC X611)

1. The Field Equipment Controller (FEC) shall be a fully user-programmable, digital controller that communicates via BACnet MS/TP protocol.
 - a. The FEC shall support BACnet Standard MS/TP Bus Protocol ASHRAE SSPC-135, Clause 9 on the controller network.
 - 1) The FEC shall be BACnet Testing Labs (BTL) certified and carry the BTL Label.
 - 2) The FEC shall be tested and certified as a BACnet Application Specific Controller (B-ASC).
 - 3) A BACnet Protocol Implementation Conformance Statement shall be provided for the FEC.
 - 4) The Conformance Statement shall be submitted 10 days prior to bidding.
2. The FEC shall employ a finite state control engine to eliminate unnecessary conflicts between control functions at crossover points in their operational sequences. Suppliers using non-state based DDC shall provide separate control strategy diagrams for all controlled functions in their submittals.
3. Controllers shall be factory programmed with a continuous adaptive tuning algorithm that senses changes in the physical environment and continually adjusts loop tuning parameters appropriately. Controllers that require manual tuning of loops or perform automatic tuning on command only shall not be acceptable. The FEC shall be assembled in a plenum-rated plastic housing with flammability rated to UL94-5VB.
4. The FEC shall include troubleshooting LED indicators to identify the following conditions:
 - a. Power On
 - b. Power Off
 - c. Download or Startup in progress, not ready for normal operation
 - d. No Faults
 - e. Device Fault
 - f. Field Controller Bus - Normal Data Transmission
 - g. Field Controller Bus - No Data Transmission
 - h. Field Controller Bus - No Communication
 - i. Sensor-Actuator Bus - Normal Data Transmission
 - j. Sensor-Actuator Bus - No Data Transmission
 - k. Sensor-Actuator Bus - No Communication
5. The FEC shall accommodate the direct wiring of analog and binary I/O field points.
6. The FEC shall support the following types of inputs and outputs:
 - a. Universal Inputs - shall be configured to monitor any of the following:
 - 1) Analog Input, Voltage Mode
 - 2) Analog Input, Current Mode
 - 3) Analog Input, Resistive Mode
 - 4) Binary Input, Dry Contact Maintained Mode

- 5) Binary Input, Pulse Counter Mode
 - b. Binary Inputs - shall be configured to monitor either of the following:
 - 1) Dry Contact Maintained Mode
 - 2) Pulse Counter Mode
 - c. Analog Outputs - shall be configured to output either of the following
 - 1) Analog Output, Voltage Mode
 - 2) Analog Output, current Mode
 - d. Binary Outputs - shall output the following:
 - 1) 24 VAC Triac
 - e. Configurable Outputs - shall be capable of the following:
 - 1) Analog Output, Voltage Mode
 - 2) Binary Output Mode.
7. The FEC shall have the ability to reside on a Field Controller Bus (FC Bus).
- a. The FC Bus shall be a Master-Slave/Token-Passing (MS/TP) Bus supporting BACnet Standard protocol SSPC-135, Clause 9.
 - b. The FC Bus shall support communications between the FECs and the NAE.
 - c. The FC Bus shall also support Input/Output Module (IOM) communications with the FEC and with the NAE.
 - d. The FC Bus shall support a minimum of 100 IOMs and FECs in any combination.
 - e. The FC Bus shall operate at a maximum distance of 15,000 Ft. between the FEC and the furthest connected device.
8. The FEC shall have the ability to monitor and control a network of sensors and actuators over a Sensor-Actuator Bus (SA Bus).
- a. The SA Bus shall be a Master-Slave/Token-Passing (MS/TP) Bus supporting BACnet Standard Protocol SSPC-135, Clause 9.
 - b. The SA Bus shall support a minimum of 10 devices per trunk.
 - c. The SA Bus shall operate at a maximum distance of 1,200 Ft. between the FEC and the furthest connected device.
9. The FEC shall have the capability to execute complex control sequences involving direct wired I/O points as well as input and output devices communicating over the FC Bus or the SA Bus.
- D. Input/Output Module (IOM X711)

1. The Input/Output Module (IOM) provides additional inputs and outputs for use in the FEC.
2. The IOM shall communicate with the FEC over the FC Bus or the SA Bus.
3. The IOM shall support BACnet Standard MS/TP Bus Protocol ASHRAE SSPC-135, Clause 9 on the controller network.
 - a. The IOM shall be BACnet Testing Labs (BTL) certified and carry the BTL Label.
 - b. The IOM shall be tested and certified as a BACnet Application Specific Controller (B-ASC).
 - c. A BACnet Protocol Implementation Conformance Statement shall be provided for the FEC.
 - d. The Conformance Statement shall be submitted 10 days prior to bidding.
4. The IOM shall be assembled in a plenum-rated plastic housing with flammability rated to UL94-5VB.
5. The IOM shall have a minimum of 4 points to a maximum of 17 points.
6. The IOM shall support the following types of inputs and outputs:
 - a. Universal Inputs - shall be configured to monitor any of the following:
 - 1) Analog Input, Voltage Mode (0- to 10-V dc)
 - 2) Analog Input, Current Mode (4 to 20 mA)
 - 3) Analog Input, Resistive Mode
 - 4) Binary Input, Dry Contact Maintained Mode
 - 5) Binary Input, Pulse Counter Mode
 - b. Binary Inputs - shall be configured to monitor either of the following:
 - 1) Dry Contact Maintained Mode
 - 2) Pulse Counter Mode
 - 3) Allow monitoring of on-off signals without external power.
 - c. Analog Outputs - shall be configured to output either of the following:
 - 1) Analog Output, Voltage Mode
 - 2) Analog Output, current Mode
 - 3) With status lights, two-position (auto-manual) switch, and manually adjustable potentiometer.
 - d. Binary Outputs - shall output the following:
 - 1) 24 VAC Triac
 - 2) Provide on-off or pulsed low-voltage signal, selectable for normally open or normally closed operation with three-position (on-off-auto) override switches and status lights.
 - e. Configurable Outputs - shall be capable of the following:
 - 1) Analog Output, Voltage Mode

2) Binary Output Mode

7. The IOM shall include troubleshooting LED indicators to identify the following conditions:
 - a. Power On
 - b. Power Off
 - c. Download or Startup in progress, not ready for normal operation
 - d. No Faults
 - e. Device Fault
 - f. Normal Data Transmission
 - g. No Data Transmission
 - h. No Communication

E. Network Sensors (NS-XXX-700X)

1. The Network Sensors (NS) shall have the ability to monitor the following variables as required by the systems sequence of operations:
 - a. Zone Temperature.
 - b. Zone Humidity.
 - c. Zone Setpoint.
 - d. Discharge Air Temperature.
 - e. Zone CO2.
2. The NS shall transmit the information back to the controller on the Sensor-Actuator Bus (SA Bus) using BACnet Standard protocol SSPC-135, Clause 9.
3. The NS shall be BACnet Testing Labs (BTL) certified and carry the BTL Label.
 - a. The NS shall be tested and certified as a BACnet Smart Sensors (B-SS).
 - b. A BACnet Protocol Implementation Conformance Statement shall be provided for the NS.
 - c. The Conformance Statement shall be submitted 10 days prior to bidding.
4. The Network Zone Temperature Sensors shall include the following items:
 - a. A backlit Liquid Crystal Display (LCD) to indicate the Temperature, Humidity and Setpoint
 - b. An LED to indicate the status of the Override feature
 - c. A button to toggle the temperature display between Fahrenheit and Celsius
 - d. A button to program the display for temperature or humidity
 - e. A button to initiate a timed override command
 - f. Available in either surface mount, wall mount, or flush mount
 - g. Available with either screw terminals or phone jack
5. The Network Discharge Air Sensors shall include the following:
 - a. 4 inch or 8 inch duct insertion probe
 - b. 10 foot pigtail lead
 - c. Dip Switches for programmable address selection

- d. Ability to provide an averaging temperature from multiple locations
 - e. Ability to provide a selectable temperature from multiple locations
6. The Network CO₂ Zone Sensors shall include the following:
- a. Available in either surface mount or wall mount
 - b. Available with screw terminals or phone jack.
- F. I/O Interface: Hardwired inputs and outputs may tie into system through controllers. Protect points so that shorting will cause no damage to controllers.
- 1. Binary Inputs: Allow monitoring of on-off signals without external power.
 - 2. Pulse Accumulation Inputs: Accept up to 10 pulses per second.
 - 3. Analog Inputs: Allow monitoring of low-voltage (0- to 10-V dc), current (4 to 20 mA), or resistance signals.
 - 4. Binary Outputs: Provide on-off or pulsed low-voltage signal, selectable for normally open or normally closed operation with three-position (on-off-auto) override switches and status lights.
 - 5. Analog Outputs: Provide modulating signal, either low voltage (0- to 10-V dc) or current (4 to 20 mA) with status lights, two-position (auto-manual) switch, and manually adjustable potentiometer.
 - 6. Tri-State Outputs: Provide two coordinated binary outputs for control of three-point, floating-type electronic actuators.
 - 7. Universal I/Os: Provide software selectable binary or analog outputs.
- G. Power Supplies: Transformers with Class 2 current-limiting type or overcurrent protection; limit connected loads to 80 percent of rated capacity. DC power supply shall match output current and voltage requirements and be full-wave rectifier type with the following:
- 1. Output ripple of 5.0 mV maximum peak to peak.
 - 2. Combined 1 percent line and load regulation with 100-mic.sec. response time for 50 percent load changes.
 - 3. Built-in overvoltage and overcurrent protection and be able to withstand 150 percent overload for at least 3 seconds without failure.
- H. Power Line Filtering: Internal or external transient voltage and surge suppression for workstations or controllers with the following:
- 1. Minimum dielectric strength of 1000 V.
 - 2. Maximum response time of 10 nanoseconds.
 - 3. Minimum transverse-mode noise attenuation of 65 dB.
 - 4. Minimum common-mode noise attenuation of 150 dB at 40 to 100 Hz.

2.8 SYSTEM TOOLS

- A. System Configuration Tool (SCT)

1. The Configuration Tool shall be a software package enabling a computer platform to be used as a stand-alone engineering configuration tool for a Network Automation Engine (NAE) or a Network Integration Engine (NIE).
2. The configuration tool shall provide an archive database for the configuration and application data.
3. The configuration tool shall have the same look-and-feel at the User Interface (UI) regardless of whether the configuration is being done online or offline.
4. The configuration tool shall include the following features:
 - a. Basic system navigation tree for connected networks
 - b. Integration of Metasys N1, LonWorks, and BACnet enabled devices
 - c. Customized user navigation trees
 - d. Point naming operating parameter setting
 - e. Graphic diagram configuration
 - f. Alarm and event message routing
 - g. Graphical logic connector tool for custom programming
 - h. Downloading, uploading, and archiving databases
5. The configuration tool shall have the capability to automatically discover field devices on connected buses and networks. Automatic discovery shall be available for the following field devices:
 - a. BACnet Devices
 - b. LonWorks devices
 - c. N2 Bus devices
 - d. Metasys N1 networks
6. The configuration tool shall be capable of programming the Field Equipment Controllers.
 - a. The configuration tool shall provide the capability to configure, simulate, and commission the Field Equipment Controllers.
 - b. The configuration tool shall allow the FECs to be run in Simulation Mode to verify the applications.
 - c. The configuration tool shall contain a library of standard applications to be used for configuration.
7. The configuration tool shall be capable of programming the field devices.
 - a. The configuration tool shall provide the capability to configure, simulate, and commission the field devices.
 - b. The configuration tool shall allow the field devices to be run in Simulation Mode to verify the applications.
 - c. The configuration tool shall contain a library of standard applications to be used for configuration
8. A wireless access point shall allow a wireless enabled portable PC to make a temporary Ethernet connection to the automation network.

- a. The wireless connection shall allow the PC to access configuration tool through the web browser using the User Interface (UI).
- b. The wireless use of configuration tool shall be the same as a wired connection in every respect.
- c. The wireless connection shall use the Bluetooth Wireless Technology.

B. Wireless MS/TP Converter (BTCVT)

1. The converter shall provide a temporary wireless connection between the SA or FC Bus and a wireless enabled portable PC.
2. The converter shall support downloading and troubleshooting FEC and field devices from the PC over the wireless connection.
3. The converter shall employ Bluetooth Wireless Technology.
4. The converter shall be powered through a connection to either the Sensor-Actuator (SA) or the Field Controller (FC) Bus.
5. The converter shall operate over a minimum of thirty three (33) feet within a building.
6. The converter shall have LED indicators to provide information regarding the following conditions:
 - a. Power - On/Off
 - b. Fault – Fault/No Fault
 - c. SA/FC Bus – Bus Activity/ No Bus Activity
 - d. Blue – Bluetooth Communication Established/ Bluetooth Communication Not Established
7. The SWCVT shall comply with FCC Part 15.247 regulations for low-power unlicensed transmitters.

2.9 ELECTRONIC SENSORS

- A. Description: Vibration and corrosion resistant; for wall, immersion, or duct mounting as required.
- B. Thermistor Temperature Sensors and Transmitters:
 1. Manufacturers:
 - a. BEC Controls Corporation.
 - b. Ebtron, Inc.
 - c. Heat-Timer Corporation.
 - d. Johnson Controls.
 - e. I.T.M. Instruments Inc.
 - f. MAMAC Systems, Inc.
 - g. RDF Corporation.
 2. Accuracy: Plus or minus 0.5 deg F at calibration point.
 3. Wire: Twisted, shielded-pair cable.

4. Insertion Elements in Ducts: Single point, 18 inches long; use where not affected by temperature stratification or where ducts are smaller than 9 sq. ft. .
5. Averaging Elements in Ducts: 72 inches long, flexible; use where prone to temperature stratification or where ducts are larger than 10 sq. ft. .
6. Insertion Elements for Liquids: Brass or stainless-steel socket with minimum insertion length of 2-1/2 inches .
7. Averaging Element in plenums, such as mixed air temperature measurements: A string of sensors mounted across the plenum to account for stratification and/or air turbulence. The averaging string to have a minimum of 4 sensing points per 12-foot long segment.
8. Room Sensor Cover Construction: Manufacturer's standard locking covers.
 - a. Set-Point Adjustment: Concealed.
 - b. Set-Point Indication: Concealed.
 - c. Thermometer: Concealed.
 - d. Color: As selected by Architect.
 - e. Orientation: Vertical.
9. Outside-Air Sensors: Watertight inlet fitting, shielded from direct sunlight.
10. Room Security Sensors: Stainless-steel cover plate with insulated back and security screws.

C. RTDs and Transmitters:

1. Manufacturers:
 - a. BEC Controls Corporation.
 - b. Johnson Controls.
 - c. MAMAC Systems, Inc.
 - d. RDF Corporation.
2. Accuracy: Plus or minus 0.2 percent at calibration point.
3. Drift: Maximum 1 deg F per year.
4. Wire: Twisted, shielded-pair cable.
5. Insertion Elements in Ducts: Single point, 18 inches long; use where not affected by temperature stratification or where ducts are smaller than 9 sq. ft. .
6. Averaging Elements in Ducts: 24 feet long, flexible; use where prone to temperature stratification or where ducts are larger than 9 sq. ft. ; length as required.
7. Insertion Elements for Liquids: Brass socket with minimum insertion length of 2-1/2 inches .
8. Room Sensor Cover Construction: Manufacturer's standard locking covers.
 - a. Set-Point Adjustment: Concealed.
 - b. Set-Point Indication: Concealed.
 - c. Thermometer: Concealed.
 - d. Color: As selected by Architect.
 - e. Orientation: Vertical.

9. Outside-Air Sensors: Watertight inlet fitting, shielded from direct sunlight. Maximum 0.5 deg F per year drift.
 10. Room Security Sensors: Stainless-steel cover plate with insulated back and security screws.
- D. Humidity Sensors: Solid-state type, bulk polymer sensor element.
1. Manufacturers:
 - a. General Eastern Instruments.
 - b. Johnson Controls.
 - c. MAMAC Systems, Inc.
 - d. TCS/Basys Controls.
 - e. Vaisala.
 - f. Veris Industries.
 2. Accuracy: 2 percent full range with linear output.
 3. Room Sensor Range: 20 to 80 percent relative humidity.
 4. Room Sensor Cover Construction: Manufacturer's standard locking covers.
 - a. Set-Point Adjustment: Concealed.
 - b. Set-Point Indication: Concealed.
 - c. Thermometer: Concealed.
 - d. Color: As selected by Architect.
 - e. Orientation: Vertical.
 5. Duct Sensor: 20 to 80 percent relative humidity range with element guard and mounting plate.
 6. Outside-Air Sensor: 20 to 80 percent relative humidity range with mounting enclosure, suitable for operation at outdoor temperatures of minus 22 to plus 185 deg F.
 7. Duct and Sensors: With element guard and mounting plate, range of 0 to 100 percent relative humidity.
- E. Pressure Transmitters/Transducers:
1. Manufacturers:
 - a. BEC Controls Corporation.
 - b. General Eastern Instruments.
 - c. Johnson Controls.
 - d. MAMAC Systems, Inc.
 - e. ROTRONIC Instrument Corp.
 - f. SETRA.
 - g. TCS/Basys Controls.
 - h. Vaisala.
 2. Static-Pressure Transmitter: Nondirectional sensor with suitable range for expected input, and temperature compensated. Industrial quality with non-interactive zero and span adjustments that are adjustable from the outside cover.

- a. Accuracy: 0.2 percent of full scale with repeatability of 0.5 percent. Maintain accuracy up to 20 to 1 ratio turndown.
 - b. Output: 4 to 20 mA.
 - c. Building Static-Pressure Range: Negative 0.5- to positive 0.5-inch wg.
 - d. Duct Static-Pressure Range: 0- to 10-inch wg.
 - e. End of Line Primary Fan System Discharge Duct Static-Pressure Range: 0- to 5-inch wg.
 - f. Return Air and Outside Air Static-Pressure Range: minus 2 to plus 2-inch wg.
3. Differential-Pressure Switch (Air or Water): Snap acting, with pilot-duty rating and with suitable scale range and differential. Provide switches with totally sealed vapor-tight switch enclosure.
 4. Pressure Transmitters: Direct acting for gas, liquid, or steam service; range suitable for system; linear output 4 to 20 mA.
 5. Air Static Pressure and Differential Pressure Sensors: Consist of a probe with pressure transducer. The probe shall be a minimum of 4 inches long to avoid influences by wall effects. The probe and transducer shall have an accuracy of +/-0.01 inch wg. over the range of the sensor with temperature variations from 0 to 160 deg F. Sensor ranges shall be approximately 1.5 times the maximum duct static pressure range at the sensor location.
- F. Room Sensor Cover Construction: Manufacturer's standard locking covers.
1. Set-Point Adjustment: Concealed.
 2. Set-Point Indication: Concealed.
 3. Thermometer: Concealed.
 4. Color: As selected by Architect.
 5. Orientation: Vertical.
- G. Room sensor accessories include the following:
1. Insulating Bases: For sensors located on exterior walls.
 2. Guards: Locking; heavy-duty, transparent plastic; mounted on separate base.
 3. Adjusting Key: As required for calibration and cover screws.
- ## 2.10 STATUS SENSORS
- A. Status Inputs for Fans: Differential-pressure switch with pilot-duty rating and with adjustable range of 0- to 5-inch wg .
- B. Status Inputs for Electric Motors: Comply with ISA 50.00.01, current-sensing fixed- or split-core transformers with self-powered transmitter, adjustable and suitable for 175 percent of rated motor current, SPDT relay, and an LED indicating the on or off status. A conductor of the load shall be passed through the window of the device. It shall accept over-current up to twice its trip point range.
1. Use current sensing switches to monitor run status for fans, pumps, and other miscellaneous motor loads.

2. Current sensing switches calibrated to show a positive run status only when the motor is operating under load. A motor running with a broken belt or coupling to indicate a negative run status.
 3. Variable Speed Status: Where current switches are used to sense the status for variable speed devices, the switches shall include on-board VA/Hz memory to allow distinction between a belt break and subsequent ramp up to 60 Hz, versus operation at low speed. The belt break scenario shall be indicated as a loss of status and the operation at low speed shall indicate normal status.
 4. Acceptable manufacturers: Veris Industries.
- C. Voltage Transmitter (100- to 600-V ac): Comply with ISA 50.00.01, single-loop, self-powered transmitter, adjustable, with suitable range and 1 percent full-scale accuracy.
- D. Current Switches: Self-powered, solid-state with adjustable trip current, selected to match current and system output requirements.
- E. Electronic Valve/Damper Position Indicator: Visual scale indicating percent of travel and 2- to 10-V dc, feedback signal.
- F. Provide Status and Safety Switches to monitor equipment status, safety conditions, and generate alarms at the BMS when a failure or abnormal condition occurs. Provide safety switches with two sets of contacts and interlock wired to shut down respective equipment.
- G. Air Filter Status Switches
1. Differential pressure switches used to monitor air filter status shall be of the automatic reset type with SPDT contacts rated for 2 amps at 120VAC.
 2. A complete installation kit shall be provided, including: static pressure taps, tubing, fittings, and air filters.
 3. Provide appropriate scale range and differential adjustment for intended service.
 4. Acceptable manufacturers: Johnson Controls, Cleveland Controls
- H. Air Flow Switches
1. Differential pressure flow switches shall be bellows actuated mercury switches or snap acting micro-switches with appropriate scale range and differential adjustment for intended service.
 2. Acceptable manufacturers: Johnson Controls, Cleveland Controls
- I. Air Pressure Safety Switches
1. Air pressure safety switches shall be of the manual reset type with SPDT contacts rated for 2 amps at 120VAC.
 2. Pressure range shall be adjustable with appropriate scale range and differential adjustment for intended service.
 3. Acceptable manufacturers: Johnson Controls, Cleveland Controls
- J. Duct Mounted Low Limit Safety Switch

1. Duct mount temperature low limit switches (Freezestats) shall be manual reset, low temperature safety switches with a minimum element length of 1 foot per square-foot of coverage which shall respond to the coldest 18 inch segment with an accuracy of 3.6 deg F. The switch shall have a field-adjustable set point with a range of at least +30 to +50 deg F. The switch shall have two sets of contacts, and each contact shall have a rating greater than its connected load. Contacts shall open or close upon drop of temperature below set point as shown and shall remain in this state until reset.

2.11 THERMOSTATS

A. Manufacturers:

1. Erie Controls.
2. Danfoss Inc.; Air-Conditioning and Refrigeration Div.
3. Heat-Timer Corporation.
4. Sauter Controls Corporation.
5. tekmar Control Systems, Inc.
6. Theben AG - Lumilite Control Technology, Inc.

B. Combination Thermostat and Fan Switches: Line-voltage thermostat with push-button or lever-operated fan switch.

1. Label switches "FAN ON-OFF" "FAN HIGH-MED-LOW-OFF" .
2. Mount on single electric switch box.

C. Low-Voltage, On-Off Thermostats: NEMA DC 3, 24-V, bimetal-operated, mercury-switch type, with adjustable or fixed anticipation heater, concealed set-point adjustment, 55 to 85 deg F set-point range, and 2 deg F maximum differential.

D. Line-Voltage, On-Off Thermostats: Bimetal-actuated, open contact or bellows-actuated, enclosed, snap-switch or equivalent solid-state type, with heat anticipator; listed for electrical rating; with concealed set-point adjustment, 55 to 85 deg F set-point range, and 2 deg F maximum differential.

1. Electric Heating Thermostats: Equip with off position on dial wired to break ungrounded conductors.
2. Selector Switch: Integral, manual on-off-auto.

2.12 ACTUATORS

A. Electric Motors: Size to operate with sufficient reserve power to provide smooth modulating action or two-position action.

1. Comply with requirements in Section 23 05 13 "Common Motor Requirements for HVAC Equipment."
2. Permanent Split-Capacitor or Shaded-Pole Type: Gear trains completely oil immersed and sealed. Equip spring-return motors with integral spiral-spring

- mechanism in housings designed for easy removal for service or adjustment of limit switches, auxiliary switches, or feedback potentiometer.
3. Nonspring-Return Motors for Valves Larger Than NPS 2-1/2 : Size for running torque of 150 in. x lbf and breakaway torque of 300 in. x lbf .
 4. Spring-Return Motors for Valves Larger Than NPS 2-1/2 : Size for running and breakaway torque of 150 in. x lbf .
 5. Nonspring-Return Motors for Dampers Larger Than 25 Sq. Ft. : Size for running torque of 150 in. x lbf and breakaway torque of 300 in. x lbf .
 6. Spring-Return Motors for Dampers Larger Than 25 Sq. Ft. : Size for running and breakaway torque of 150 in. x lbf .
- B. Electronic Actuators: Direct-coupled type designed for minimum 60,000 full-stroke cycles at rated torque.
1. Manufacturers:
 - a. Belimo Aircontrols (USA), Inc.
 - b. Johnson Controls.
 2. Steam Control Valves: Shutoff against 1.5 times steam design pressure.
 3. Dampers: Size for running torque calculated as follows:
 - a. Deliver torque required for continuous uniform movement of controlled device from limit to limit when operated at rated voltage.
 - b. Parallel-Blade Damper with Edge Seals: 7 inch-lb/sq. ft. of damper.
 - c. Opposed-Blade Damper with Edge Seals: 5 inch-lb/sq. ft. of damper.
 - d. Parallel-Blade Damper without Edge Seals: 4 inch-lb/sq. ft. of damper.
 - e. Opposed-Blade Damper without Edge Seals: 3 inch-lb/sq. ft. of damper.
 - f. Dampers with 2- to 3-Inch wg of Pressure Drop or Face Velocities of 1000 to 2500 fpm : Increase running torque by 1.5.
 - g. Dampers with 3- to 4-Inch wg of Pressure Drop or Face Velocities of 2500 to 3000 fpm : Increase running torque by 2.0.
 4. Coupling: V-bolt and V-shaped, toothed cradle.
 5. Overload Protection: Electronic overload or digital rotation-sensing circuitry. Function properly within a range of 85 to 120 percent of nameplate voltage
 6. Fail-Safe Operation: Mechanical, spring-return mechanism for Normally Open (NO) and Normally Closed (NC) positions. Provide external, manual gear release on nonspring-return actuators. Include a visible position indicator and graduated scale on each actuator. Easily switchable from fail open to fail closed in the field without replacement.
 7. Gear Type Actuators: External manual adjustment mechanism to allow manual positioning when the actuator is not powered.
 8. Power Requirements (Two-Position Spring Return): 24-V ac.
 9. Power Requirements (Modulating): Maximum 10 VA at 24-V ac or 8 W at 24-V dc.
 10. Proportional Signal: 2- to 10-V dc or 4 to 20 mA, and 2- to 10-V dc position feedback signal. Three Point, Tristate, or Floating Point inputs are not acceptable.
 11. Temperature Rating: Minus 22 to plus 122 deg F.

12. Temperature Rating (Smoke Dampers): Minus 22 to plus 250 deg F.
13. Sound: 62 dBA for spring return and 45 dBA for non-spring return.
14. Stroke Time: Operate valve from fully closed to fully open or vice versa within 60- to 90- seconds.
15. Programmable Multi-Function:
 - a. Control Input, Position Feedback, and Running Time: Factory or field programmable.
 - b. Diagnostic: Feedback of hunting or oscillation, mechanical overload, mechanical travel, and mechanical load limit.
 - c. Service Data: Include, at a minimum, number of hours powered and number of hours in motion.

2.13 CONTROL VALVES

A. Manufacturers:

1. Bray Controls; a division of Bray International.
2. Hayward Industrial Products, Inc.
3. Johnson Controls, Inc.; Controls Group.
4. Neles-Jamesbury.

B. Control Valves: Factory fabricated, of type, ANSI/ASME B16.34 body material, and ANSI/ASME B16.15 pressure class based on 150 percent of the system design operating pressure and temperature rating of piping system, unless otherwise indicated. Unless otherwise specified or shown, valve leakage shall meet ANSI/FCI 70-2 Class IV leakage rating (0.01 percent of valve Kv).

1. Special Warranty: Manufacturer's standard, but not less than three years from the date of Substantial Completion for the valve and linkage.

C. Steam system globe valves shall have the following characteristics:

1. NPS 2 and Smaller: Class 250 bronze body, bronze trim, rising stainless steel stem, stainless steel disc/plug/seat, and screwed ends with backseating capacity repackable under pressure.
2. NPS 2-1/2 and Larger: Class 125 iron body, bronze trim, rising stainless steel stem, plug-type disc, flanged ends, and renewable seat and disc.
3. Internal Construction: Replaceable plugs and stainless-steel seats and stem.
 - a. Single-Seated Valves: Cage trim provides seating and guiding surfaces for plug on top and bottom of guided plugs.
 - b. Double-Seated Valves: Balanced plug; cage trim provides seating and guiding surfaces for plugs on top and bottom of guided plugs.
4. Sizing: For pressure drop based on the following services:
 - a. Two Position: 20 percent of inlet pressure.
 - b. Modulating 15-psig Steam: 80 percent of inlet steam pressure.
5. Flow Characteristics: Modified linear flow characteristics.

6. Close-Off (Differential) Pressure Rating: Combination of actuator and trim shall provide minimum close-off pressure rating of 150 percent of operating (inlet) pressure.
7. Construct the valves to be serviceable from the top.
8. Furnish each control valve with a corrosion-resistant nameplate indicating the following:
 - a. Manufacturer's name, model number, and serial number.
 - b. Body and trim size.
 - c. Arrow indicating direction of flow.
- 9.

2.14 DAMPERS

A. Manufacturers:

1. Air Balance Inc.
2. Johnson Controls.
3. Ruskin.
4. United Enertech Corp.

B. Dampers: AMCA-rated, parallel or opposed-blade design; 0.108-inch- minimum thick, galvanized-steel or 0.125-inch- minimum thick, extruded-aluminum frames with holes for duct mounting; damper blades shall not be less than 0.064-inch- thick galvanized steel with maximum blade width of 8 inches, length of 48 inches 72 inches.

1. Secure blades to minimum 1/2-inch- diameter, zinc-plated axles using zinc-plated hardware, with oil-impregnated sintered bronze blade bearings, blade-linkage hardware of zinc-plated steel and brass, ends sealed against spring-stainless-steel blade bearings, and thrust bearings at each end of every blade.
2. Operating Temperature Range: From minus 40 to plus 200 deg F .
3. Edge Seals, Standard Pressure Applications: Closed-cell neoprene.
4. Edge Seals, Low-Leakage Applications: Use inflatable blade edging or replaceable rubber blade seals and spring-loaded stainless-steel side seals, rated for leakage at less than 10 cfm per sq. ft. of damper area, at differential pressure of 4-inch wg when damper is held by torque of 50 in. x lbf ; when tested according to AMCA 500D.

2.15 CONTROL CABLE

A. Optical Fiber Cable

1. Manufacturers: Subject to compliance with requirements, provide products by one of the following:
 - a. Berk-Tek; a Nexans company.
 - b. CommScope, Inc.
 - c. Corning Cable Systems.
 - d. General Cable Technologies Corporation.
 - e. Mohawk; a division of Belden CDT.

- f. Nordex/CDT; a subsidiary of Cable Design Technologies.
 - g. Optical Connectivity Solutions Division; Emerson Network Power.
 - h. Superior Essex Inc.
 - i. SYSTIMAX Solutions; a CommScope, Inc. brand.
 - j. 3M.
 - k. Tyco Electronics/AMP Netconnect; Tyco International Ltd.
2. Description: Multimode, 62.5/125-micrometer, 24-fiber, nonconductive, tight buffer, optical fiber cable.
 - a. Comply with ICEA S-83-596 for mechanical properties.
 - b. Comply with TIA/EIA-568-B.3 for performance specifications.
 - c. Comply with TIA/EIA-492AAAA-A for detailed specifications.
 - d. Listed and labeled by an NRTL acceptable to authorities having jurisdiction as complying with UL 444, UL 1651, and NFPA 70 for the following types:
 - 1) General Purpose, Nonconductive: Type OFN or OFNG.
 - 2) Plenum Rated, Nonconductive: Type OFNP, complying with NFPA 262.
 - 3) Riser Rated, Nonconductive: Type OFNR, complying with UL 1666.
 - e. Conductive cable shall be aluminum armored type.
 - f. Maximum Attenuation: 3.50 dB/km at 850 nm; 1.5 dB/km at 1300 nm.
 - g. Minimum Modal Bandwidth: 160 MHz-km at 850 nm; 500 MHz-km at 1300 nm.
 3. Jacket:
 - a. Jacket Color: Orange for 62.5/125-micrometer cable .
 - b. Cable cordage jacket, fiber, unit, and group color shall be according to TIA/EIA-598-B.
 - c. Imprinted with fiber count, fiber type, and aggregate length at regular intervals not to exceed 40 inches.
- B. Low-Voltage Control Cable
1. Paired Cable: NFPA 70, Type CMG.
 - a. 1 pair, twisted, No. 16 AWG, stranded (19x29) and No. 18 AWG, stranded (19x30) tinned copper conductors.
 - b. PVC insulation.
 - c. Unshielded.
 - d. PVC jacket.
 - e. Flame Resistance: Comply with UL 1581.
 2. Plenum-Rated, Paired Cable: NFPA 70, Type CMP.
 - a. 1 pair, twisted, No. 16 AWG, stranded (19x29) and No. 18 AWG, stranded (19x30) tinned copper conductors.
 - b. PVC insulation.

- c. Unshielded.
- d. PVC jacket.
- e. Flame Resistance: Comply with NFPA 262.

C. Control-Circuit Conductors

- 1. Class 1 Control Circuits: Stranded copper, Type THHN-THWN, complying with UL 83, in raceway.
- 2. Class 2 Control Circuits: Stranded copper, Type THHN-THWN, complying with UL 83, in raceway or power-limited cable, complying with UL 83, concealed in building finishes.
- 3. Class 3 Remote-Control and Signal Circuits: Stranded copper, Type TW or TF, complying with UL 83.

D. Electrical work required for system products and installation shall meet or exceed those specified in applicable portions of Division 26 ELECTRICAL.

E. All electric wiring incidental to all control, interlock, combination control/power (Line voltage or low voltage) and safety devices covered under this section of the specifications shall be the direct responsibility of the BMS Supplier.

F. Provide complete electric wiring for DDC System, including wiring to transformer primaries.

- 1. Control circuit conductors which run in the same conduit as power circuit conductors shall have the same insulation level as power circuit conductors. Circuits operating at more than 100 Volts shall be in accordance with Division 26 Sections.
- 2. Circuits operating at 100 Volts or less shall be defined as low voltage and shall be run in rigid or flexible conduit, metallic tubing, metal raceways or wire trays, armored cable, or multiconductor cable. Use multiconductor cable for concealed accessible locations only.
- 3. Provide circuit and wiring protection as required by NFPA 70. Aluminum-sheathed cable or aluminum conduit shall not be used.
- 4. Wiring through the masonry wall shall be run in conduit and junction box. Install conduit so wires may be removed and replaced at a later date.
- 5. AC Control Wiring:
 - a. Control wiring for 24 V circuits shall be insulated copper 18 AWG minimum and shall be rated for 300 VAC service.
 - b. Wiring for 120 V shall be 14 AWG minimum and shall be rated for 600 V service.
- 6. Analog Signal Wiring:
 - a. Analog signal wiring for analog inputs and analog outputs shall be 18 AWG single or multiple twisted pair. Each cable shall be 100 percent shielded, and have 20 AWG drain wire. Exception is direct connect RTD wiring which shall be a single 18 AWG minimum twisted pair, 100 percent shielded, and with 20 AWG drain wire.

- b. Each wire shall have insulation rated to 300 V ac.
 - c. Cables shall have an overall aluminum-polyester or tinned-copper (cable-shield tape), overall 20 AWG tinned copper cable drain wire, and overall cable insulation rated to 300 V ac.
 - d. Install analog signal wiring in conduit separate from AC power circuits.
7. Low-voltage wiring shall meet NEC Class 2 requirements. Subfuse low-voltage power circuits as required to meet Class 2 current limit.
 8. Include one pull string in each raceway 2.5 cm (1 in.) or larger.
- G. Wiring within Enclosures: Bundle, lace, and train conductors to terminal points. Use lacing bars and distribution spools. Separate power-limited and non-power-limited conductors as recommended in writing by manufacturer. Install conductors parallel with or at right angles to sides and back of enclosure. Connect conductors that are terminated, spliced, or interrupted in any enclosure associated with intrusion system to terminal blocks. Mark each terminal according to system's wiring diagrams. Make all connections with approved crimp-on terminal spade lugs, pressure-type terminal blocks, or plug connectors.

2.16 MISCELLANEOUS DEVICES

A. Local Control Panels

1. All control panels shall be factory constructed, incorporating the BMS manufacturer's standard designs and layouts. All control panels shall be UL inspected and listed as an assembly and carries a UL 508 label listing compliance. Control panels shall be fully enclosed, with perforated sub-panel, lockable hinged door, and slotted flush latch.
2. Unitized cabinet with suitable brackets for wall or floor mounting, located adjacent to each system under automatic control. Fabricate of 0.06-inch-thick, furniture-quality steel or extruded-aluminum alloy, totally enclosed, with hinged doors and keyed lock and with manufacturer's standard shop-painted finish. Provide common keying for all panels.
3. In general, the control panels shall consist of the DDC controller(s), display module as specified and indicated on the plans, and I/O devices—such as relays, transducers, and so forth—that are not required to be located external to the control panel due to function. Where specified the display module shall be flush mounted in the panel face unless otherwise noted.
4. Provide all I/O connections on the DDC controller via removable or fixed screw terminals.
5. Segregate low and line voltage wiring. All provided terminal strips and wiring shall be UL listed, 300-volt service, and provide adequate clearance for field wiring.
6. All wiring shall be neatly installed in plastic trays or tie-wrapped and label each terminations.
7. Provide a 120 volt, 20 AMP convenience duplex outlet, fused on/off power switch, and required transformers in each enclosure.

8. Graphics: Color-coded graphic, laminated-plastic displays on doors, schematically showing system being controlled, with protective, clear plastic sheet bonded to entire door.
 9. Enclosures: Comply with the following minimum requirements:
 - a. Outdoors: NEMA 250 Type 4.
 - b. Mechanical and Electrical Rooms: NEMA 250 Type 12.
 - c. All Other Locations: NEMA 250 Type 1.
- B. Power Supplies
1. UL Listed. Transformers with Class 2 current-limiting type or overcurrent protection in both primary and secondary circuits for Class 2 service in accordance with NEC requirements
 2. Size DC power supplies for the connected device load. Total rated load not to exceed 75 percent of the rated capacity of the power supply.
 3. Input: 120 VAC +10 percent, 60Hz.
 4. Output: 24 VDC.
 5. Line Regulation: +0.05 percent for 10 percent line change.
 6. Load Regulation: +0.05 percent for 50 percent load change.
 7. Ripple and Noise: 1 mV rms, 5 mV peak to peak.
 8. Provide an appropriately sized fuse and fuse block and locate next to the power supply.
 9. Provide a power disconnect switch next to the power supply.
- C. Power Line Filtering: Internal or external transient voltage and surge suppression for workstations or controllers with the following:
1. Minimum dielectric strength of 1000 V.
 2. Maximum response time of 10 nanoseconds.
 3. Minimum transverse-mode noise attenuation of 65 dB.
 4. Minimum common-mode noise attenuation of 150 dB at 40 to 100 Hz.
- D. All safety devices, low temperature and high temperature, shall be connected to the BMS.
- E. All auxiliary devices such as EP switches, differential pressure switches, PE switches, end switches, time delay relays and relays of all descriptions required to provide the specified sequence of operation and fail safe features shall be furnished and installed whether or not they are specifically mentioned.
- F. Control Relays: Open contact, electronic type with a dust-proof enclosures having capacity suitable for the load controlled. Double-pole, double-throw (DPDT), UL listed, with a minimum 10 AMP resistive rating at rated voltage, or rated to the application and with an enclosed coil. Equip with a light indicator that will lit when the coil is energized and will be off when coil is not energized. Relays shall be socket type, plug into a fixed base, and be replaceable without the need of tools or removing wiring.
- G. Time Delay Relays. Time delay relays shall be solid-state plug-in type, UL listed, and shall have adjustable time delay. Delay shall be adjustable ± 100 percent from setpoint

shown. Contact rating, configuration, and coil voltage shall be suitable for application. Provide NEMA 1 enclosure for relays not installed in local control panel.

- H. Pilot Lights and Manual Switches: Device illumination shall be by light-emitting diode(LEDs) or neon lamps. Switches shall have operating levers and index plates showing switch positions and name of apparatus controlled or other appropriate designations.
- I. Transformers: UL 506 and NEMA ST 1 as applicable. Transformers, other than transformers in bridge circuits, shall have primaries wound for available voltage and secondaries wound for correct control circuit voltage. Transformers shall be sized so that connected loads equal 80 percent of rated capacity. Transformers shall be enclosed in rustproof, galvanized steel enclosure with conduit connections. Disconnect switch shall be provided on the primary side and a fuse cutout on the secondary side.
- J. Override Timers: Override timers shall be manually set, electronic digital type, without a "HOLD" feature. Time intervals shall be selectable for up to 6 hours of operation and shall revert from occupied to unoccupied settings unless reset. Flush mount timer on local control panel face or where shown.
- K. Surge Protection: Surge and transient protection consist of devices installed externally to digital controllers.
 - 1. Power Line Surge Protection: Surge suppressors external to digital controller, shall be installed on all incoming AC power. Surge suppressor shall be rated by UL 1449, and have clamping voltage ratings below the following levels:
 - a. Normal Mode (Line to Neutral): 350 Volts
 - b. Common Mode (Line to Ground): 350 Volts
 - 2. Telephone and Communication Line Surge Protection
 - a. Protected from surges. Metal oxide varistor (MOV) protection, rated for the application, shall be installed at the equipment. Additional protection, gas tubes rated for the application, shall be installed within 3 feet of the building cable entrance or within 3 feet of the telephone company's network interface.
 - 3. Sensor and Control Wiring Surge Protection
 - a. Controllers shall have sensor and control wiring surge protection with optical isolation, metal oxide varistors (MOV), or silicon avalanche devices. Fuses are not permitted for surge protection.

PART 3 - EXECUTION

3.1 EXAMINATION

- A. Verify that power supply is available to control units and operator workstation.
- B. Examine drawings and specifications for work of others. Report inadequate headroom or space conditions or other discrepancies to Engineer and obtain written instructions for changes necessary to accommodate work of this Section with work of others. Controls Installer shall perform at its expense necessary changes in specified work caused by failure or neglect to report discrepancies.

3.2 DEMOLITION AND REUSE OF EXISTING MATERIALS AND EQUIPMENT

- A. Wiring: Interconnecting control wiring shall be removed and shall become Installer's property unless specifically noted or shown to be reused.
- B. Local Control Panels: Remove control panels.
- C. Repair: Unless otherwise directed, Installer is not responsible for repair or replacement of existing energy equipment and systems, valves, dampers, or actuators. Notify Owner in writing immediately of existing equipment that requires maintenance.
- D. Indicator Gauges: Ensure operation of and recalibrate for reasonable accuracy or replace existing gauges.
- E. Room Thermostats: Remove and deliver existing room thermostats to Owner unless otherwise noted. Patch and finish holes and marks left by removal to match existing walls.
- F. Electronic Sensors and Transmitters: Remove and deliver existing sensors and transmitters to Owner.
- G. Controllers and Auxiliary Electronic Devices: Remove and deliver existing controllers and auxiliary electronic devices to Owner.
- H. Damper Actuators, Linkages, and Appurtenances: Remove and deliver existing damper actuators, linkages and appurtenances to Owner.
- I. Control Valves: Replace existing control valves with new. Deliver removed control valves to Owner.
- J. Pneumatic Components: Remove all pneumatic components and tubing in their entirety for all new DDC system.
- K. Existing System Operating Schedule: Mechanical system shall remain in operation and shall maintain space comfort at all times between the hours of 6 a.m. and 6 p.m., Monday through Friday. Modifications to the system shall not affect space comfort conditions or cause mechanical system to be shut down for more than 15 minutes. Perform cutover of controls that cannot meet these conditions outside of operational hours.

- L. Maintain fan scheduling using existing or temporary time clocks or control systems throughout the control system installation.
- M. Modify existing starter control circuits if necessary to provide hand-off-auto control of each controlled starter. Furnish new starters or starter control packages as required.
- N. Patch holes and finish matching existing walls, cabinets. Repair or replace insulation disturbed by the removal of existing equipment and devices.

3.3 SEQUENCE OF WORK FOR EXISTING SYSTEMS CONVERSION

- A. General: All work involving changeover of control functions from existing pneumatic/DDC control system to the new DDC BMS shall be performed in accordance with the following sequence in order to minimize the duration of equipment outages. The following descriptions are intended to indicate the sequence in which the work shall be performed, not to define fully the scope of the work.
- B. Install and/or upgrade web server, operator's workstation, peripherals, graphic software, and LAN prior to placing any equipment under the control of the new BMS.
- C. Work which requires shutting down a pump motor, fan motor, boilers or chiller shall be considered a utility shutdown and shall be subject to the restrictions specified in Section 01 50 00 "Temporary Facilities and Controls."
- D. The following sequence applies to an individually controlled HVAC subsystem, such as an air handling unit. Only one such system shall be placed under manual control (as described below) at any given time.
- E. Install controllers adjacent to (or within) existing control panels. Programming shall be complete (except for loading and debugging) prior to installation. Install all field devices, which do not require interruption of the existing control system.
- F. Install all conduit, wiring, and pneumatic tubing which do not require interruption of the existing control system.
- G. Provide temporary variable pressure type hand pumps at each pneumatically controlled output, for temporary use by the Owner's maintenance and operation contractor personnel. Schedule this step at least 48 hours in advance with the Building Engineer.
- H. Remove existing controls including wiring, conduit, and tubing (except materials to be reused in accordance with provisions specified elsewhere) which must be removed to facilitate installation of new BMS materials and equipment.
- I. Remove existing digital control system points (if applicable). Install and calibrate remainder of new BMS materials and equipment for this subsystem. Load controller software. Connect controller(s) to LAN.

- J. Perform all field testing and calibration that does not require connection of permanent pneumatic outputs.
- K. Remove temporary hand pumps and install permanent pneumatic output connections. Place the system under the control of the new DDC/BMS equipment. Conclude field testing and submit field testing report prior to placing the next subsystem under temporary manual control. The Owner shall be given a password with a priority level that allows monitoring (but not control until notification of substantial completion has been approved).
- L. Remove remaining existing pneumatic and digital control system materials and equipment (except materials to be reused in accordance with provisions specified elsewhere). All existing digital controls equipment for those subsystems that have not yet been converted shall remain intact, on-line, and fully functional.
- M. Schedule work in Owner occupied spaces three (3) days in advance with the Owner's representative.

3.4 INSTALLATION

- A. Install software in control units, field control panels, and operator workstation(s). Implement all features of programs to specified requirements and as appropriate to sequence of operation.
- B. Connect and configure equipment and software to achieve sequence of operation specified.
- C. Verify location of thermostats, humidistats, and other exposed control sensors with Drawings and room details before installation. Install devices 48 inches above the floor, as per ADA requirements.
 - 1. Install averaging elements in ducts and plenums in crossing or zigzag pattern.
- D. Install automatic dampers according to Section 23 33 00 "Air Duct Accessories." Adjust the damper linkage such that the damper closes before the actuator is fully closed to assure tight shutoff of the damper.
 - 1. Blank-off and seal around dampers and between dampers and sleeves or frames to eliminate air bypass.
 - 2. For outdoor air damper assemblies, stage the opening of each section to prevent stratification and poor mixing of outside and return air.
- E. Install damper motors on outside of duct in warm areas, not in locations exposed to outdoor temperatures.
- F. Install labels and nameplates to identify control components according to Section 23 05 53 "Identification for HVAC Piping and Equipment."

1. Post laminated copies of the As-built control system drawings in each Mechanical room and where directed by the Owner.
 2. Post laminated copies of the system schematics, graphics in Boiler Room and where directed by the Owner.
 3. Use valve tags for control valves. Include control valves on Valve Schedule.
 4. Label control panel enclosures.
 5. Label all sensors, controllers, and controlled devices.
 6. Match identification on the labels or tags with the identification documented on the submittals/as-builts.
- G. Install steam and condensate instrument wells, valves, and other accessories according to Section 23 22 16 "Steam and Condensate Piping Specialties."
- H. Install field-installed controls, devices, and control panels, furnished in other sections of the Division 22 and 23, and provide related wiring and miscellaneous control devices. Coordinate exact requirements with other Division 22 and 23 sections.
- I. Install equipment, piping, and wiring or raceway horizontally, vertically, and parallel to walls wherever possible.
- J. Provide sufficient slack and flexible connections to allow for piping and equipment vibration isolation.
- K. Install equipment in readily accessible locations as defined by National Electrical Code (NEC) Chapter 1 Article 100 Part A.
- L. Affix permanent warning labels to equipment that can be automatically started by the control system.
1. Labels shall use white lettering (12-point type or larger) on a red background.
 2. Warning labels shall read as follows;

CAUTION
This equipment is operating under automatic control and may start or stop at any time without warning. Switch disconnect to "Off" position before servicing.

- M. Affix permanent warning labels to motor starters and control panels that are connected to multiple power sources utilizing separate disconnects.
1. Labels shall use white lettering (12-point type or larger) on a red background.
 2. Warning labels shall read as follows;

CAUTION
This equipment is fed from more than one power source with separate disconnects. Disconnect all power sources before servicing.

3.5 ELECTRICAL WIRING AND CONNECTION INSTALLATION

- A. Install raceways, boxes, and cabinets according to Section 26 05 33 "Raceways and Boxes for Electrical Systems."

- B. Install building wire and cable according to Section 26 05 19 "Low-Voltage Power Conductors and Cables."
- C. Power and Control-Circuit Conductors:
 - 1. 120-V Power Wiring: All NEC Class 1 (line voltage) wiring shall be UL Listed in approved raceway according to NEC and Section 26 05 19 "Low-Voltage Power Conductors and Cables" unless otherwise indicated.
 - 2. Minimum Conductor Sizes:
 - a. Class 1 remote-control and signal circuits, No. 14 AWG.
 - b. Class 2 low-energy, remote-control and signal circuits, No. 16 AWG.
 - c. Class 3 low-energy, remote-control, alarm and signal circuits, No. 12 AWG.
- D. Signal and communication cables.
 - 1. Conceal cable, except in mechanical rooms and areas where other conduit and piping are exposed. Install all wiring in mechanical, electrical, or service rooms, or where subject to mechanical damage in raceway. Maintain minimum clearance of 6 inch (150 mm) between raceway and high-temperature equipment such as steam pipes or flues.
 - 2. Install exposed cable in raceway.
 - 3. Install concealed cable in raceway. Raceway is not required for Class 2 (24 VAC or less) wiring in concealed accessible locations. Support Class 2 wiring not installed in conduit every 5 feet from the building structure utilizing metal hangers designed for this application. Where plenum cables are used without raceway, they shall be supported from or anchored to structural members. Cables shall not be supported by or anchored to ductwork, electrical raceways, piping, or ceiling suspension systems.
 - 4. Bundle and harness multiconductor instrument cable in place of single cables where several cables follow a common path.
 - 5. Fasten flexible conductors, bridging cabinets and doors, along hinge side; protect against abrasion. Tie and support conductors.
 - 6. Number-code or color-code conductors for future identification and service of control system, except local individual room control cables.
 - 7. Install wire and cable with sufficient slack and flexible connections, maximum 3 feet in length to allow for vibration of piping and equipment.
 - 8. Class 2 signal wiring and 24VAC power can be run in the same raceway. Power wiring 120VAC and greater cannot share the same raceway with Class 2 signal wiring.
 - 9. Minimum raceway size shall be 3/4 inch.
 - 10. Control and data transmission wiring shall not share conduit with other building wiring systems.
 - 11. Locate control and status relays in designated enclosures only. Do not install control and status relays in packaged equipment control panel enclosures containing Class 1 starters.
 - 12. Flexible metal raceways and liquid-tight flexible metal raceways shall not exceed 3 feet (1 m) in length and shall be supported at each end. Do not use flexible metal raceway less than 1/2 inch electrical trade size. Use liquid-tight flexible metal raceways in areas exposed to moisture including chiller and boiler rooms.

13. Install all control wiring exposed in existing construction in surface mounted raceways (Wiremold) painted to match the mounting surface.
 14. Raceway Supports:
 - a. Single runs: Galvanized conduit straps or ring bolt type hangers with specialty spring clips. Do not use plumber's perforated straps.
 - b. Multiple runs: Conduit rack with 25 percent spare capacity.
 - c. Vertical runs: Channel support with conduit fittings.
 15. Use coded conductors throughout with conductors of different colors.
- E. Comply with NECA 1.
- F. Conductors: Size according to system manufacturer's written instructions unless otherwise indicated.
- G. General Requirements for Cabling:
1. Comply with TIA/EIA-568-B.1.
 2. Comply with BICSI ITSIM, Chapter 6, "Cable Termination Practices."
 3. Terminate all conductors; no cable shall contain unterminated elements. Make terminations only at indicated outlets, terminals, and cross-connect and patch panels.
 4. Cables may not be spliced. Secure and support cables at intervals not exceeding 30 inches and not more than 6 inches from cabinets, boxes, fittings, outlets, racks, frames, and terminals.
 5. Bundle, lace, and train conductors to terminal points without exceeding manufacturer's limitations on bending radii, but not less than radii specified in BICSI ITSIM, "Cabling Termination Practices" Chapter. Install lacing bars and distribution spools.
 6. Do not install bruised, kinked, scored, deformed, or abraded cable. Do not splice cable between termination, tap, or junction points. Remove and discard cable if damaged during installation and replace it with new cable.
 7. Cold-Weather Installation: Bring cable to room temperature before dereeling. Heat lamps shall not be used for heating.
 8. Pulling Cable: Comply with BICSI ITSIM, Chapter 4, "Pulling Cable." Monitor cable pull tensions.
- H. Optical Fiber Cable Installation:
1. Comply with TIA/EIA-568-B.3.
 2. Cable shall be terminated on connecting hardware that is rack or cabinet mounted.
- I. Open-Cable Installation:
1. Install cabling with horizontal and vertical cable guides with terminating hardware and interconnection equipment.
 2. Suspend copper cable not in a wireway or pathway a minimum of 8 inches above ceilings by cable supports not more than 60 inches apart.

3. Cable shall not be run through structural members or in contact with pipes, ducts, or other potentially damaging items.
- J. Separation from EMI Sources:
1. Comply with BICSI TDMM and TIA-569-B recommendations for separating unshielded copper voice and data communication cable from potential EMI sources, including electrical power lines and equipment.
 2. Separation between open communications cables or cables in nonmetallic raceways and unshielded power conductors and electrical equipment shall be as follows:
 - a. Electrical Equipment Rating Less Than 2 kVA: A minimum of 5 inches.
 - b. Electrical Equipment Rating between 2 and 5 kVA: A minimum of 12 inches.
 - c. Electrical Equipment Rating More Than 5 kVA: A minimum of 24 inches.
 3. Separation between communications cables in grounded metallic raceways and unshielded power lines or electrical equipment shall be as follows:
 - a. Electrical Equipment Rating Less Than 2 kVA: A minimum of 2-1/2 inches.
 - b. Electrical Equipment Rating between 2 and 5 kVA: A minimum of 6 inches.
 - c. Electrical Equipment Rating More Than 5 kVA: A minimum of 12 inches.
 4. Separation between communications cables in grounded metallic raceways and power lines and electrical equipment located in grounded metallic conduits or enclosures shall be as follows:
 - a. Electrical Equipment Rating Less Than 2 kVA: No requirement.
 - b. Electrical Equipment Rating between 2 and 5 kVA: A minimum of 3 inches.
 - c. Electrical Equipment Rating More Than 5 kVA: A minimum of 6 inches.
 5. Separation between Cables and Electrical Motors and Transformers, 5 kVA or HP and Larger: A minimum of 48 inches.
 6. Separation between Cables and Fluorescent Fixtures: A minimum of 5 inches.
- K. Connect manual-reset limit controls independent of manual-control switch positions. Automatic duct heater resets may be connected in interlock circuit of power controllers.
- L. Connect hand-off-auto selector switches to override automatic interlock controls when switch is in hand position.
- M. Provide necessary power to each controller and control panel and provide transformers not installed by the equipment manufacturer.
- N. Coordinate all electrical work with this installation with the Division 26 Contractor.
- O. The BMS Supplier shall furnish and install all required interlock wiring unless otherwise specified. The BMS Supplier shall carefully coordinate his work with equipment manufacturers.

P. Identification:

1. Identify system components, wiring, and cabling complying with TIA/EIA-606-A. Comply with requirements for identification specified in Section 26 05 53 "Electrical Identification."
2. Permanently label each field wire, cable at each end with unique identification. Number-code or color-code conductors for future identification and service of control system, except local individual room control cables.
3. Label wiring and cabling, including that within factory-fabricated panels, with control system address or termination number at each end within 2 inch (50 mm) of termination.
4. Permanently label or code each point of field terminal strips to show instrument or item served.
5. Label control panels with laminated plastic nameplates.
6. Label each control component with a permanent label. Label plug-in components such that label remain stationary during component replacement.
7. Label room sensors related to terminal boxes or valves with nameplates.
8. Manufacturers' nameplates and UL or CSA labels shall be visible and legible after equipment is installed.
9. Label identifiers shall match record documents.

Q. DDC Line Voltage Power Source

1. 120-volt AC circuits used for the DDC System shall be taken from panel boards and circuit breakers provided by Division 26.
2. Circuits used for the DDC shall be dedicated to the DDC and shall not be used for any other purposes.
3. DDC terminal unit controllers may use AC power from motor power circuits.
4. The circuit or circuits within the distribution panels shall be so marked.
5. Minimum conduit size shall be 3/4 inch.

R. Fiber Optic Cable System

1. All cabling shall be installed in a neat and workmanlike manner. Minimum cable and unjacketed fiber bend radii as specified by cable manufacturer shall be maintained.
2. Maximum pulling tensions as specified by the cable manufacturer shall not be exceeded during installation. Post installation residual cable tension shall be within cable manufacture's specifications.
3. Fiber optic cabinets, hardware, and cable entering the cabinet shall be installed in accordance with manufacturers' instructions. Minimum cable and unjacketed fiber bend radii as specified by cable manufacturer shall be maintained.

3.6 THERMOSTATS OR SENSORS INSTALLATION

- A. Room thermostats/sensors: Install at location indicated on the drawings, but the System Installer shall carefully check the architectural and electrical drawings to verify the locations indicated. The Architect shall review any relocation of room thermostats

to avoid conflict with other trades or, at the System Installer's recommendation, to improve performance.

- B. Individual room control shall be furnished and installed for each separately heated space whether or not a room thermostat is shown on the drawings.
- C. The absence of an indication of control devices such as room thermostat, sensor, humidistat, or other devices on the drawings will not relieve the System Installer of furnishing appropriate control devices in accordance with the intent of this section of the specifications.
- D. Provide room temperature sensors with push button or lever index switches for manual override in Offices.
- E. Temperature Sensors: Provide temperature sensors in locations to sense the appropriate condition. Provide sensor where they are easy to access and service without special tools. Calibrate sensors to accuracy specified. In no case will sensors designed for one application be installed for another application.
 - 1. Room Temperature Sensors: Provide on interior walls to sense average room temperature conditions. Avoid locations that may be covered by office furniture. Room temperature sensors should not be mounted on exterior walls when other locations are available. Align with lighting switches and humidistats.
 - a. Mount centerline of sensor at 60 inches above finished floor. Mount center line of ADA accessible sensor with override switch at 48 inches above finished floor.
 - 2. Duct Temperature Sensors:
 - a. Provide sensors in ductwork at appropriate. Select specific sensor location within duct to accurately sense appropriate air temperatures. Do not locate sensors in dead air spaces or positions obstructed by ducts or equipment. Install gaskets between the sensor housing and duct wall. Seal duct and insulation penetrations.
 - b. String duct averaging sensors between two rigid supports in a serpentine position to sense average conditions. Thermally isolate temperature-sensing elements from supports. Provide duct access doors to averaging sensors.
 - 3. Outside Air Temperature Sensors: Provide outside air temperature sensor on north side of the building, away from exhaust hoods, air intakes and other areas that may affect temperature readings. Provide sun shields to protect outside air sensor from direct sunlight.
 - 4. Low Temperature Protection Temperature Switch: For each 25 square feet of coil-face area, provide a temperature switch to sense the temperature at the location shown. Provide temperature switch sensing element in a serpentine pattern.
- F. Install sensors according to manufacturer's recommendations.

- G. Mount sensors rigidly and adequately for operating environment.
- H. Install room temperature sensors on concealed junction boxes properly supported by wall framing.
- I. Air seal wires attached to sensors in their raceways or in the wall to prevent sensor readings from being affected by air transmitted from other areas.
- J. Use averaging sensors in mixing plenums and hot and cold decks. Install averaging sensors in a serpentine manner vertically across duct. Support each bend with a capillary clip.
- K. Install mixing plenum low-limit sensors in a serpentine manner horizontally across duct. Support each bend with a capillary clip. Provide 3 m (1 ft) of sensing element for each 1 square feet (1 square meter) of coil area.
- L. Install pipe-mounted temperature sensors in wells. Install liquid temperature sensors with heat-conducting fluid in thermal wells.
- M. Piping to pressure transducer pressure ports shall contain a capped test port adjacent to transducer.
- N. Pressure transducers, except those controlling VAV boxes, shall be located in control panels, not on monitored equipment or on ductwork. Mount transducers in a vibration-free location accessible for service without use of ladders or special equipment.
- O. Mount gauge tees adjacent to air and water differential pressure taps. Install shut-off valves before tee for water gauges.
- P. Duct Static Pressure Sensors: The duct static pressure sensing tap shall be located at 75 percent to 100 percent of the distance between the first and last air terminal units' PIM damper. If the transmitter output is a 4-20 mA or 0-10Vdc signal, the transmitter shall be located in the same enclosure as the air handling unit (AHU) controller for the AHU serving the terminal units.

3.7 CONNECTIONS

- A. Piping installation requirements are specified in other Division 23 Sections. Drawings indicate general arrangement of piping, fittings, and specialties.
 - 1. Install piping adjacent to machine to allow service and maintenance.
- B. Provide connection to the equipment control panel(s).
 - 1. Provide interface wiring between the equipment panels, safety control devices, and to the DDC panel. Each alarm of the equipment controls shall be transmitted to the Central Panel and OWS.
 - 2. Install and wire remote interface panel and other field-installed accessories supplied by the equipment manufacturer.

3. Install and wire three differential pressure transmitters, flow transducers, and temperature transmitters for the variable pumping system.
- C. Provide connection to the variable frequency drive control panel(s).
- D. Ground equipment.
1. Tighten electrical connectors and terminals according to manufacturer's published torque-tightening values. If manufacturer's torque values are not indicated, use those specified in UL 486A and UL 486B.

3.8 FIRESTOPPING

- A. Comply with requirements in Section 07 84 13 "Penetration Firestopping."
- B. Comply with TIA-569-B, "Firestopping" Annex A.
- C. Comply with BICSI TDMM, "Firestopping Systems" Article.

3.9 GROUNDING

- A. For communications wiring, comply with ANSI-J-STD-607-A and with BICSI TDMM, "Grounding, Bonding, and Electrical Protection" Chapter.
- B. For low-voltage wiring and cabling, comply with requirements in Section 26 05 26 "Grounding and Bonding."
- C. Grounding: Ground controllers and cabinets to a good earth ground. Ground controller to a ground in accordance with Division 26. Grounding of the green ac ground wire, at the breaker panel, alone is not adequate. Run metal conduit from controller panels to adequate building grounds. Ground sensor drain wire shields at controller end.
 1. Correct all associated ground loop problems.

3.10 CONTROL VALVES INSTALLATION

- A. Steam System, Two-Way Applications Controlled by Pressure: Globe-style, two-way valves.
- B. Steam System,, Two Way, Controlled by Temperature: Globe-style, two-way valves.
- C. Install control valves in an accessible location, with room for actuator removal and service. Adjust the actuator to provide tight shutoff. Provide valve stem indicator and adjust to indicate proper travel.

3.11 PROGRAMMING FOR PROGRAMMABLE DEVICES

- A. These requirements apply to programmable process controllers.
- B. Create and download application programs that meet the requirements of the sequence of control, time scheduling requirements, trend logging requirements and alarm handling requirements.
- C. Use a consistent point naming concept throughout the project that allows for easy transition from building to building and system to system.
- D. All time schedules shall be fully configured with weekly schedules and all of the holidays identified by the Owner.
- E. All trend logs identified in the sequence of operation shall be fully configured and operational.
- F. All alarm handling shall be fully configured with consistent alarm messages and priorities or category numbers to identify the system from which the alarm originates.
- G. All application parameters identified as (adj) in the sequence of control shall be exposed as viewable parameters and appropriate initial values shall be set.
- H. All external point values and internal point values identified as (rpt) in the sequence of operation shall be exposed as viewable values.
- I. Manual control of all external points shall be programmed using either the priority override concept or the software switchover concept.
- J. For all variables broadcast onto the field bus, event driven communication shall be used to avoid data storms. As a minimum the program shall provide for the send on delta parameter and minimum send time parameter for each output variable.
- K. Embed into the programs sufficient comment statements to clearly describe each section of the program. This applies to both line programming and graphical programming systems.
- L. If graphical programming systems with multiple layers for the functional block diagrams are used, no more than two layers shall be used.
- M. Device-to-Device Data Flow:
 - 1. All device-to-device data flow shall be in place and configured to meet the sequence of operation.
 - 2. Appropriate binding services shall be used to ensure that the average bandwidth utilization is less than 30 percent.
 - 3. If reducing the number of devices per field bus is required to meet the network bandwidth requirements, all costs of making changes shall be borne by the Installer.
- N. Distributed Control Requirements:

1. The programmed applications for a single integrated system shall not be distributed over more than one field bus. Examples:
 - a. A chiller is controlled by a controller on field bus number 1. The controllers that control the pumps and tower shall also be on field bus number 1 as these systems are integrated in their control requirements.
 - b. Multiple air handling units are controlled by controllers on field bus number 1. The chiller system is controlled by controllers on field bus number 2. The chiller control logic requires the chilled water valve positions from each of the air handling unit controllers. It is acceptable that these related but non-integral systems are controlled by controllers on different field busses.

O. Password Setup

1. Existing password setup to remain.

3.12 FIELD QUALITY CONTROL

- A. Manufacturer's Field Service: Engage a factory-authorized service representative to inspect, test, and adjust field-assembled components and equipment installation, including connections, and to assist in field testing. Report results in writing.
- B. Perform the following field tests and inspections and prepare test reports:
 1. Operational Test: After electrical circuitry has been energized, start units to confirm proper unit operation. Remove and replace malfunctioning units and retest.
 2. Test and adjust controls and safeties.
 3. Test calibration of electronic controllers by disconnecting input sensors and stimulating operation with compatible signal generator.
 4. Test each point through its full operating range to verify that safety and operating control set points are as required.
 5. Test each control loop to verify stable mode of operation and compliance with sequence of operation. Adjust PID actions.
 6. Test each system for compliance with sequence of operation.
 7. Test software and hardware interlocks and alarms.
- C. Engage a factory-authorized service representative to perform startup service.
- D. Replace damaged or malfunctioning controls and equipment.
 1. Start, test, and adjust control systems.
 2. Demonstrate compliance with requirements, including calibration and testing, and control sequences.
 3. Adjust, calibrate, and fine tune circuits and equipment to achieve sequence of operation specified.
- E. DDC Verification:

1. Verify that instruments are installed before calibration, testing, and loop or leak checks.
 2. Check instruments for proper location and accessibility.
 3. Check instrument installation for direction of flow, elevation, orientation, insertion depth, and other applicable considerations.
 4. Check instrument tubing for proper fittings, slope, material, and support.
 5. Check installation of air supply for each instrument.
 6. Check flow instruments. Inspect tag number and line and bore size, and verify that inlet side is identified and that meters are installed correctly.
 7. Check pressure instruments, piping slope, installation of valve manifold, and self-contained pressure regulators.
 8. Check temperature instruments and material and length of sensing elements.
 9. Check control valves. Verify that they are in correct direction.
 10. Check DDC system as follows:
 - a. Verify that DDC controller power supply is from emergency power supply, if applicable.
 - b. Verify that wires at control panels are tagged with their service designation and approved tagging system.
 - c. Verify that spare I/O capacity has been provided.
 - d. Verify that DDC controllers are protected from power supply surges.
- F. Replace damaged or malfunctioning controls and equipment and repeat testing procedures.
- G. Performance Verification Test: Conduct the performance verification tests to demonstrate control system maintains set points, control loops are tuned, and controllers are programmed for the correct sequence of operation. Conduct performance verification test during one week of continuous HVAC and DDC systems operation and before final acceptance of work. Specifically the performance verification test shall demonstrate the following:
1. Execution of Sequence of Operation: Furnish the Owner graphed trends to show the sequence of operation is executed in correct order. Demonstrate the HVAC system operates properly through the complete sequence of operation, for example seasonal, occupied/unoccupied, warm-up. Demonstrate proper control system response for abnormal conditions for which there is a specified response by simulating these conditions. Demonstrate hardware interlocks and safeties work. Demonstrate the control system performs the correct sequence of control after a loss of power.
 2. Software: Demonstrate that the required software is installed in each of the operator interface devices and DDC controllers. Demonstrate that the graphics screens, alarms, trends, and reports are installed as specified, submitted and approved.
 3. Interrogation and Command: Demonstrate that each of the points specified and shown can be interrogated and/or commanded (as applicable) from each Operator Interface Device and controllers as specified.
 4. Remote Dial-Up: Demonstrate that remote dial-up communication abilities are in accordance with Construction Documents.

5. Calibration: Demonstrate that the calibration of each of the input/output devices is correct by using the same methods specified for the Commissioning Tests. A minimum of 10 percent of the I/O points shall be selected at random for this demonstration. Upon failure of one device to meet the specified end-to-end accuracy, an additional 10 percent of I/O points shall be selected at random for this demonstration. This process shall be repeated until 100 percent of randomly selected I/O points have been demonstrated to meet specified end-to-end accuracy.
 6. Remote Location Software: Demonstrate that the DDC and other specified point-related software programs exist at respective controllers. The DDC programming and point database shall be as submitted and approved.
 7. Control Loop Stability and Accuracy: Furnish the Owner graphed trends of control loops to demonstrate the control loop is stable and that set point is maintained. Control loop response shall respond to set point changes and stabilize in 1 minute. Control loop trend data shall be instantaneous and the time between data points shall not be greater than one minute.
 8. Opposite Season Test: Repeat the performance verification test during an opposite season to the first performance verification test. Test procedures of the performance verification test shall be used for the opposite season test.
 9. Demonstrate complete operation of operator interface.
 10. Demand limiting. Supply trend data output showing demand-limiting algorithm action. Trend data shall document action sampled each minute over at least a 30-minute period and shall show building kW, demand-limiting setpoint, and status of setpoints and other affected equipment parameters.
 11. Building fire alarm system interface.
 12. Trend logs for each system. Trend data shall indicate setpoints, operating points, valve positions, and other data as specified in the points list provided with each sequence of operation. Each log shall cover three 48-hour periods and shall have a sample frequency not less than 10 minutes or as specified on its points list. Logs shall be accessible through system's operator interface and shall be retrievable for use in other software programs.
 13. Provide at least two persons equipped with two-way communication.
 14. Tests that fail to demonstrate proper system operation shall be repeated after Installer makes necessary repairs or revisions to hardware or software to successfully complete each test.
 15. Acceptance:
 - a. After tests described in this specification are performed to the satisfaction of both Engineer and Owner, Engineer will accept control system as meeting completion requirements. Engineer may exempt tests from completion requirements that cannot be performed due to circumstances beyond Installer's control. Engineer will provide written statement of each exempted test. Exempted tests shall be performed as part of warranty.
 - b. System shall not be accepted until completed demonstration forms and checklists are submitted and approved
- H. Post laminated copies of the As-built control system drawings in each Mechanical room, Boiler Room, and where directed by the Owner.

3.13 COMMISSIONING

- A. Manufacturer's Field Services: Provide the services of a factory authorized service representative to start up the DDC System, and to commission each component included in the DDC System.
- B. Controls and Safeties: Test and adjust controls and safeties as follows:
 - 1. Inspection: Inspect each individual control panel, component, field device, the connecting wiring, and terminations for proper installation, correct placement, and conformance to shop drawings.
 - 2. Labeling: Label each field device with the point ID, date and time of verification, and the commissioning technician's initials.
 - 3. Testing and Calibration: Test, calibrate, and set each of the digital and analog sensing and actuating devices. Calibrate each instrumentation device by making a comparison between the central computer or field control panel display and the reading at the device, using an instrument traceable to the National Bureau of Standards, which shall be at least twice as accurate as the device to be calibrated. Record the measured value and displayed value for each device in the Commissioning Report.
 - 4. Checking and Setting Zero and Span Adjustments: Check and set zero and span adjustments for each of the actuating devices. Manually activate damper and valve operators to verify free travel and fail condition. Check valve or damper to insure that it shuts off tight when the appropriate signal is applied to the operator.
 - 5. Checking Digital and Analog Control Points: Check each individual digital and analog control point by making a comparison between the control command at the operator's console and the status of the controlled device while switching the unit from one state to the other, i.e., starting and stopping a fan. Check each digital input point by making a comparison of the state of the sensing device and the console display. Record the results for each device in the Commissioning Report.
 - 6. Validate Sequences of Operation: Verify each sequence of operation by using the approved commissioning checklists to record results and submit the sheets with the Commissioning Report. Verify proper sequence of operation of specified functions on each of the systems being controlled by the DDC System.
 - 7. Tuning Control Loops: Tune each control loop to obtain the fastest stable response without hunting, offset, or overshoot.

3.14 ADJUSTING

- A. Calibrating and Adjusting:
 - 1. Calibrate instruments.
 - 2. Make three-point calibration test for both linearity and accuracy for each analog instrument.
 - 3. Calibrate equipment and procedures using manufacturer's written recommendations and instruction manuals. Use test equipment with accuracy at least double that of instrument being calibrated.
 - 4. Control System Inputs and Outputs:
 - a. Check analog inputs at 0, 50, and 100 percent of span.

- b. Check analog outputs using milliampere meter at 0, 50, and 100 percent output.
 - c. Check digital inputs using jumper wire.
 - d. Check digital outputs using ohmmeter to test for contact making or breaking.
 - e. Check resistance temperature inputs at 0, 50, and 100 percent of span using a precision-resistant source.
 5. Flow:
 - a. Set differential pressure flow transmitters for 0 and 100 percent values with 3-point calibration accomplished at 50, 90, and 100 percent of span.
 - b. Manually operate flow switches to verify that they make or break contact.
 6. Pressure:
 - a. Calibrate pressure transmitters at 0, 50, and 100 percent of span.
 - b. Calibrate pressure switches to make or break contacts, with adjustable differential set at minimum.
 7. Temperature:
 - a. Calibrate resistance temperature transmitters at 0, 50, and 100 percent of span using a precision-resistance source.
 - b. Calibrate temperature switches to make or break contacts.
 8. Stroke and adjust control valves and dampers without positioners, following the manufacturer's recommended procedure, so that valve or damper is 100 percent open and closed.
 9. Stroke and adjust control valves and dampers with positioners, following manufacturer's recommended procedure, so that valve and damper is 0, 50, and 100 percent closed.
 10. Provide diagnostic and test instruments for calibration and adjustment of system.
 11. Provide written description of procedures and equipment for calibrating each type of instrument. Submit procedures review and approval before initiating startup procedures.
 - B. Adjust initial temperature and humidity set points.
 - C. Occupancy Adjustments: When requested within 12 months of date of Substantial Completion, provide on-site assistance in adjusting system to suit actual occupied conditions. Provide up to four visits to Project during other than normal occupancy hours for this purpose.
- 3.15 DEMONSTRATION
- A. Engage a factory-authorized service representative to train Owner's maintenance personnel to adjust, operate, and maintain HVAC instrumentation and controls.

1. Provide a training course schedule, syllabus, and training materials 45 days prior to the start of training. Orient training to the specific system being installed under this Project. Use operation and maintenance manual as the primary instructional aid in Installer provided activity personnel training. Base training on the Operations and Maintenance manuals and a DDC training manual.
2. Training Manuals shall be delivered for each trainee with two additional sets delivered for archiving at the project site. Training manuals shall include an agenda, defined objectives, and a detailed description of the subject matter for each lesson.
 - a. Furnish audio-visual equipment and all other training materials and supplies.
 - b. A training day is defined as 8 hours of classroom or lab instruction, including two 15 minute breaks and excluding lunch time, Monday through Friday, during the daytime shift in effect at the training facility. For guidance, the Installer should assume the attendees will have a high school education and are familiar with HVAC systems.
3. Train Owner's maintenance personnel on procedures and schedules for starting and stopping, troubleshooting, servicing, and maintaining equipment and schedules.
4. Provide operator training on data display, alarm and status descriptors, requesting data, executing commands, calibrating and adjusting devices, resetting default values, and requesting logs.
5. Operator Training I: The first class shall be taught for a period of 1 consecutive training day at least 1 month prior to the scheduled Performance Verification Test. The first course shall be taught in an Owner provided facility. Training shall be classroom, but have hands-on operation of similar digital controllers. A maximum of 5 personnel will attend this course. Upon completion of this course, each student, using appropriate documentation, should be able to perform elementary operations, with guidance, and describe the general hardware architecture and functionality of the system. This course shall include but not be limited to:
 - a. Theory of operation
 - b. Hardware architecture
 - c. Operation of the system
 - d. Operator commands
 - e. Control sequence programming
 - f. Data base entry
 - g. Reports and logs
 - h. Alarm reports
 - i. Diagnostics
 - j. Upon completion of this course, students should be fully proficient in the operation of each system function. Prepare a written report describing the skill level of each student at the end of this course.
6. Maintenance Personnel Training

- a. The system maintenance course shall be taught at the project site within one month after the completion of the endurance test for a period of 1 training day. A maximum of five personnel will attend the course. The course shall include but not be limited to:
 - 1) Physical layout of each piece of hardware
 - 2) Troubleshooting and diagnostics procedures
 - 3) Repair instructions
 - 4) Preventive maintenance procedures and schedules
 - 5) Calibration procedures.
 - b. Troubleshooting, checkout and calibration of the working system shall be accomplished in a classroom setting and repeated on-site.
7. Start-Up and Instruction: When all systems have been assessed by the System Installer to have been successfully carried through complete operational tests with not less than a minimum of simulation, and the Architect concurs in this assessment, start-up by the Owner's operating personnel can follow.
8. Training shall enable students to accomplish the following objectives.
- a. Proficiently operate system
 - b. Understand control system architecture and configuration
 - c. Understand DDC system components
 - d. Understand system operation, including DDC system control and optimizing routines (algorithms)
 - e. Operate workstation and peripherals
 - f. Log on and off system
 - g. Access graphics, point reports, and logs
 - h. Adjust and change system setpoints, time schedules, and holiday schedules
 - i. Recognize common HVAC system malfunctions by observing system graphics, trend graphs, and other system tools
 - j. Understand system drawings and Operation and Maintenance manual
 - k. Understand job layout and location of control components
 - l. Access data from DDC controllers
 - m. Operate portable operator's terminals
 - n. Create and change system graphics
 - o. Create, delete, and modify alarms, including configuring alarm reactions
 - p. Create, delete, and modify point trend logs (graphs) and multi-point trend graphs
 - q. Configure and run reports
 - r. Add, remove, and modify system's physical points
 - s. Create, modify, and delete application programming
 - t. Add operator interface stations
 - u. Add a new controller to system
 - v. Download firmware and advanced applications programming to a controller
 - w. Configure and calibrate I/O points
 - x. Maintain software and prepare backups
 - y. Interface with job-specific, third-party operator software
 - z. Add new users and understand password security procedures

9. Divide presentation of objectives into three sessions (a-m, n-w, and x-z). Participants will attend one or more of sessions, depending on knowledge level required.
 - a. Day-to-day Operators (objectives a-m)
 - b. Advanced Operators (objectives a-m and n-w)
 - c. System Managers and Administrators (objectives a-m and x-z)
10. Include a minimum of 8 hours' dedicated instructor time on-site and/or at Owner designated location.
11. Review data in maintenance manuals. Refer to Section 01 78 23 "Operation and Maintenance Data."
12. Schedule training with Owner, through Architect, with at least seven days' advance notice.
13. It shall be possible for the operator to modify system functions independently after receiving the training from the System Installer as hereinafter specified.

3.16 ACCEPTANCE PERIOD

- A. General: After approval of the BMS Demonstration and prior to Contract Close-Out, the system shall enter an Acceptance Period of at least four weeks of uninterrupted operation. The Contractor shall schedule the beginning of the Acceptance Period with the Owner at least 2 weeks in advance. During the Acceptance Period, the system shall operate properly without malfunction, without alarm caused by control action or device failure, and with smooth and stable control of systems and equipment in conformance with these Specifications. At the end of the four-week period, the Contractor shall provide written notification of the pass/fail status of the Acceptance Period to the Owner, including documentation identifying each of the problems experienced. If the system failed the tests, the Contractor shall provide notice to the Owner that each of the problems has been corrected. The Acceptance Period shall be restarted at a mutually scheduled time for an additional one-week period. This process shall be repeated until the system has passed the Acceptance Period without exception.
- B. Hard Copy Log of Alarms: During the Acceptance Period, the Contractor shall maintain a hard copy log of each of the alarms generated by the field control panels. For each alarm received, the Contractor shall diagnose the cause of the alarm, and shall list on the log for each alarm the diagnosed cause of the alarm, and the required corrective action taken. If, in the Contractor's opinion, the cause of the alarm is not the responsibility of the Contractor, the Contractor shall immediately notify the Owner's representative.
- C. Trend Logs: During the Acceptance Period, the Contractor shall maintain the entire controller network and workstation hardware and software in a state that will allow remote access by the Owner for other representatives to access Trend Logs as discussed below:
 1. General: Prepare controller and workstation software to display graphical format trend logs during the Acceptance Period. Trend logs shall demonstrate

- compliance with contract documents. Trend logs shall be set up to meet the following requirements.
2. Reset Schedule: Trend Logs shall include each of the analog and digital input values, analog and digital output values, and set points, both manual and as determined by a reset schedule.
 3. Line Differentiation: Lines shall be labeled and shall be distinguished from each other by using either different line types or different line colors.
 4. Graphic Keys: Indicate engineering units on the y-axis values; e.g. degrees F., inches wg, Btu/lb, and percent wide open.
 5. Compatible Values: The x-axis scale shall be chosen so that each of the rendered values are in a readable range. Incompatible ranges of analog and digital points shall not be mixed on the automatically formatted graphics. The operator may choose to manually select these points at will.
 6. Outside Air Trending: Trend outside air temperature, humidity, and enthalpy during each period in which other points are trended.
 7. System Uniformity: Each of the points trended for one HVAC subsystem (e.g. air handling unit, chilled water system, PDU system, and hot water system) shall be trended during the same trend period.
 8. Labeling: Each graph shall be clearly labeled with HVAC subsystem title, date and times.
 9. Trend Log Schedule: A complete set of trend logs shall consist of each of the required points, trended for 24 hours with 5-minute intervals.

END OF SECTION 23 09 00

SECTION 232213

STEAM AND CONDENSATE HEATING PIPING

PART 1 - GENERAL

1.1 RELATED DOCUMENTS

- A. Drawings and general provisions of the Contract, including General and Supplementary Conditions and Division 01 Specification Sections, apply to this Section.

1.2 SUMMARY

- A. Section includes pipe and fittings for HP steam and condensate piping:
- B. Related Requirements:
 - 1. Section 232216 "Steam and Condensate Piping Specialties" for strainers, special-duty valves, steam traps, thermostatic air vents and vacuum breakers.

1.3 ACTION SUBMITTALS

- A. Product Data: For RTRP and RTRF and adhesive.

1.4 INFORMATIONAL SUBMITTALS

- A. Coordination Drawings: Piping layout, drawn to scale, on which the following items are shown and coordinated with each other, using input from installers of the items involved:
 - 1. Suspended ceiling components.
 - 2. Other building services.
 - 3. Structural members.
- B. Qualification Data: For Installer.
- C. Welding certificates.
- D. Field quality-control reports.

1.5 QUALITY ASSURANCE

- A. Installer Qualifications:

1. Fiberglass Pipe and Fitting Installers: Installers of RTRF and RTRP shall be certified by the manufacturer of pipes and fittings as having been trained and qualified to join fiberglass piping with manufacturer-recommended adhesive.
- B. Steel Support Welding: Qualify procedures and personnel according to AWS D1.1/D1.1M, "Structural Welding Code - Steel."
- C. Pipe Welding: Qualify procedures and operators according to the following:
 1. ASME Compliance: Comply with ASME B31.1, "Power Piping," and ASME B31.9, "Building Services Piping," for materials, products, and installation.
 2. Certify that each welder has passed AWS qualification tests for welding processes involved and that certification is current.

PART 2 - PRODUCTS

2.1 PERFORMANCE REQUIREMENTS

- A. Components and installation shall be capable of withstanding the following minimum working pressures and temperatures unless otherwise indicated:
 1. HP Steam Piping: 100 psig.
 2. Condensate Piping: 100 psig at 338 deg F.
 3. Blowdown-Drain Piping: Equal to pressure of the piping system to which it is attached.
 4. Air-Vent and Vacuum-Breaker Piping: Equal to pressure of the piping system to which it is attached.
 5. Safety-Valve-Inlet and -Outlet Piping: Equal to pressure of the piping system to which it is attached.

2.2 STEEL PIPE AND FITTINGS

- A. Steel Pipe: ASTM A 53/A 53M, black steel, plain ends, welded and seamless, Grade B, and Schedule as indicated in piping applications articles.
- B. Cast-Iron Threaded Fittings: ASME B16.4; Classes 125, 150, and 300 as indicated in piping applications articles.
- C. Malleable-Iron Threaded Fittings: ASME B16.3; Classes 150 and 300 as indicated in piping applications articles.
- D. Malleable-Iron Unions: ASME B16.39; Classes 150, 250, and 300 as indicated in piping applications articles.
- E. Cast-Iron Threaded Flanges and Flanged Fittings: ASME B16.1, Classes 125 and 250 as indicated in piping applications articles; raised ground face, and bolt holes spot faced.

- F. Wrought-Steel Fittings: ASTM A 234/A 234M, wall thickness to match adjoining pipe.
- G. Wrought-Steel Flanges and Flanged Fittings: ASME B16.5, including bolts, nuts, and gaskets of the following material group, end connections, and facings:
 - 1. Material Group: 1.1.
 - 2. End Connections: Butt welding.
 - 3. Facings: Raised face.
- H. Steel Pipe Nipples: ASTM A 733, made of ASTM A 53/A 53M, black steel of same Type, Grade, and Schedule as pipe in which installed.

2.3 JOINING MATERIALS

- A. Pipe-Flange Gasket Materials: Suitable for chemical and thermal conditions of piping system contents.
 - 1. ASME B16.21, nonmetallic, flat, asbestos free, 1/8-inch maximum thickness unless otherwise indicated.
 - a. Full-Face Type: For flat-face, Class 125, cast-iron and cast-bronze flanges.
 - b. Narrow-Face Type: For raised-face, Class 250, cast-iron and steel flanges.
- B. Flange Bolts and Nuts: ASME B18.2.1, carbon steel, unless otherwise indicated.
- C. Welding Filler Metals: Comply with AWS D10.12M/D10.12 for welding materials appropriate for wall thickness and chemical analysis of steel pipe being welded.
- D. Welding Materials: Comply with Section II, Part C, of ASME Boiler and Pressure Vessel Code for welding materials appropriate for wall thickness and for chemical analysis of pipe being welded.

PART 3 - EXECUTION

3.1 HP STEAM PIPING APPLICATIONS

- A. HP Steam Piping, NPS 2 and Smaller: Schedule 80, Type S, Grade B, steel pipe; Class 125 cast-iron fittings; and threaded joints.
- B. HP Steam Piping, NPS 2-1/2 through NPS 12: Schedule 80, Type E, Grade B, steel pipe; Class 150 wrought-steel fittings, flanges, and flange fittings; and welded and flanged joints.
- C. Condensate piping above grade, NPS 2 and smaller, shall be the following:
 - 1. Schedule 80, Type S, Grade B, steel pipe; Class 125 cast-iron fittings; and threaded joints.

- D. Condensate piping above grade, NPS 2-1/2 and larger, shall be the following:
 - 1. Schedule 80, Type E, Grade B, steel pipe; Class 150 wrought-steel fittings, flanges, and flange fittings; and welded and flanged joints.

3.2 ANCILLARY PIPING APPLICATIONS

- A. Blowdown-Drain Piping: Same materials and joining methods as for piping specified for the service in which blowdown drain is installed.
- B. Vacuum-Breaker Piping: Outlet, same as service where installed.
- C. Safety-Valve-Inlet and -Outlet Piping: Same materials and joining methods as for piping specified for the service in which safety valve is installed.

3.3 PIPING INSTALLATION

- A. Drawing plans, schematics, and diagrams indicate general location and arrangement of piping systems. Install piping as indicated unless deviations to layout are approved on Coordination Drawings.
- B. Install piping indicated to be exposed and piping in equipment rooms and service areas at right angles or parallel to building walls. Diagonal runs are prohibited unless otherwise indicated.
- C. Install piping to permit valve servicing.
- D. Install piping free of sags and bends.
- E. Install fittings for changes in direction and branch connections.
- F. Install piping to allow application of insulation.
- G. Select system components with pressure rating equal to or greater than system operating pressure.
- H. Install groups of pipes parallel to each other, spaced to permit applying insulation and servicing of valves.
- I. Install drains, consisting of a tee fitting, NPS 3/4 full port-ball valve, and short NPS 3/4 threaded nipple with cap, at low points in piping system mains and elsewhere as required for system drainage.
- J. Install steam supply piping at a minimum uniform grade of 0.2 percent downward in direction of steam flow.
- K. Install condensate return piping at a minimum uniform grade of 0.4 percent downward in direction of condensate flow.

- L. Reduce pipe sizes using eccentric reducer fitting installed with level side down.
- M. Install branch connections to mains using mechanically formed tee fittings in main pipe, with the branch connected to top of main pipe.
- N. Install valves according to Section 230523 "General-Duty Valves for HVAC Piping."
- O. Install unions in piping, NPS 2 and smaller, adjacent to valves, at final connections of equipment, and elsewhere as indicated.
- P. Install flanges in piping, NPS 2-1/2 and larger, at final connections of equipment and elsewhere as indicated.
- Q. Install shutoff valve immediately upstream of each dielectric fitting.
- R. Install strainers on supply side of control valves, pressure-reducing valves, traps, and elsewhere as indicated. Install NPS 3/4 nipple and full port ball valve in blowdown connection of strainers NPS 2 and larger. Match size of strainer blowoff connection for strainers smaller than NPS 2.
- S. Comply with requirements in Section 230553 "Identification for HVAC Piping and Equipment" for identifying piping.

3.4 STEAM AND CONDENSATE PIPING SPECIALTIES INSTALLATION

- A. Comply with requirements in Section 232216 "Steam and Condensate Piping Specialties" for installation requirements for strainers, flash tanks, special-duty valves, steam traps, thermostatic air vents and vacuum breakers, and steam and condensate meters.

3.5 HANGERS AND SUPPORTS

- A. Comply with requirements in Section 230529 "Hangers and Supports for HVAC Piping and Equipment" for installation of hangers and supports. Comply with requirements below for maximum spacing.
- B. Install the following pipe attachments:
 - 1. Adjustable steel clevis hangers for individual horizontal piping less than 20 feet long.
- C. Install hangers for steel steam supply piping with the following maximum spacing:
 - 1. NPS 3/4: Maximum span, 9 feet.
 - 2. NPS 1: Maximum span, 9 feet.
 - 3. NPS 1-1/2: Maximum span, 12 feet.
 - 4. NPS 2: Maximum span, 13 feet.
 - 5. NPS 2-1/2: Maximum span, 14 feet.

6. NPS 3 and Larger: Maximum span, 15 feet.
- D. Install hangers for steel steam condensate piping with the following maximum spacing:
1. NPS 3/4: Maximum span, 7 feet.
 2. NPS 1: Maximum span, 7 feet.
 3. NPS 1-1/2: Maximum span, 9 feet.
 4. NPS 2: Maximum span, 10 feet.
 5. NPS 2-1/2: Maximum span, 11 feet.
 6. NPS 3 and Larger: Maximum span, 12 feet

3.6 PIPE JOINT CONSTRUCTION

- A. Ream ends of pipes and remove burrs. Bevel plain ends of steel pipe.
- B. Remove scale, slag, dirt, and debris from inside and outside of pipe and fittings before assembly.
- C. Threaded Joints: Thread pipe with tapered pipe threads according to ASME B1.20.1. Cut threads full and clean using sharp dies. Ream threaded pipe ends to remove burrs and restore full ID. Join pipe fittings and valves as follows:
1. Apply appropriate tape or thread compound to external pipe threads unless dry seal threading is specified.
 2. Damaged Threads: Do not use pipe or pipe fittings with threads that are corroded or damaged. Do not use pipe sections that have cracked or open welds.
- D. Welded Joints: Construct joints according to AWS D10.12M/D10.12, using qualified processes and welding operators according to "Quality Assurance" Article.
- E. Flanged Joints: Select appropriate gasket material, size, type, and thickness for service application. Install gasket concentrically positioned. Use suitable lubricants on bolt threads.
- F. Fiberglass Bonded Joints: Prepare pipe ends and fittings, apply adhesive, and join according to pipe manufacturer's written instructions.

3.7 TERMINAL EQUIPMENT CONNECTIONS

- A. Size for supply and return piping connections shall be the same as or larger than equipment connections.
- B. Install traps and control valves in accessible locations close to connected equipment.
- C. Install bypass piping with globe valve around control valve. If parallel control valves are installed, only one bypass is required.
- D. Install vacuum breakers downstream from control valve, close to coil inlet connection.

- E. Install a drip leg at coil outlet.

3.8 FIELD QUALITY CONTROL

- A. Prepare steam and condensate piping according to ASME B31.1, "Power Piping," and ASME B31.9, "Building Services Piping," and as follows:
 - 1. Leave joints, including welds, un-insulated and exposed for examination during test.
 - 2. Flush system with clean water. Clean strainers.
 - 3. Isolate equipment from piping. If a valve is used to isolate equipment, its closure shall be capable of sealing against test pressure without damage to valve. Install blinds in flanged joints to isolate equipment.
- B. Perform the following tests and inspections:
 - 1. Use ambient temperature water as a testing medium unless there is risk of damage due to freezing. Another liquid that is safe for workers and compatible with piping may be used.
 - 2. Subject piping system to hydrostatic test pressure that is not less than 1.5 times the working pressure. Test pressure shall not exceed maximum pressure for any vessel, pump, valve, or other component in system under test. Verify that stress due to pressure at bottom of vertical runs does not exceed 90 percent of specified minimum yield strength.
 - 3. After hydrostatic test pressure has been applied for at least 10 minutes, examine piping, joints, and connections for leakage. Eliminate leaks by tightening, repairing, or replacing components, and repeat hydrostatic test until there are no leaks.
- C. Prepare test and inspection reports.

END OF SECTION 232213

SECTION 232216

STEAM AND CONDENSATE PIPING SPECIALTIES

PART 1 - GENERAL

1.1 RELATED DOCUMENTS

- A. Drawings and general provisions of the Contract, including General and Supplementary Conditions and Division 01 Specification Sections, apply to this Section.

1.2 SUMMARY

- A. Section includes the following piping specialties for LP and HP steam and condensate piping:
 - 1. Strainers.
 - 2. Safety valves.
 - 3. Steam traps.
 - 4. Thermostatic air vents and vacuum breakers.

1.3 ACTION SUBMITTALS

- A. Product Data: For each type of the following:
 - 1. Safety valve.
 - 2. Steam trap.
 - 3. Air vent and vacuum breaker.

1.4 CLOSEOUT SUBMITTALS

- A. Operation and Maintenance Data: For valves, safety valves, pressure-reducing valves, steam traps, air vents, vacuum breakers, and meters to include in emergency, operation, and maintenance manuals.

1.5 QUALITY ASSURANCE

- A. Pipe Welding: Qualify procedures and operators according to the following:
 - 1. ASME Compliance: Safety valves and pressure vessels shall bear the appropriate ASME label. Fabricate and stamp flash tanks to comply with ASME Boiler and Pressure Vessel Code: Section VIII, Division 1.

PART 2 - PRODUCTS

2.1 PERFORMANCE REQUIREMENTS

- A. Components and installation shall be capable of withstanding the following minimum working pressures and temperatures unless otherwise indicated:
1. HP Steam Piping: 100 psig.
 2. Condensate Piping: 100 psig at 338 deg F.
 3. Blowdown-Drain Piping: Equal to pressure of the piping system to which it is attached.
 4. Air-Vent and Vacuum-Breaker Piping: Equal to pressure of the piping system to which it is attached.
 5. Safety-Valve-Inlet and -Outlet Piping: Equal to pressure of the piping system to which it is attached.

2.2 VALVES

- A. Gate, Globe, and Check Valves: Comply with requirements specified in Section 230523 "General-Duty Valves for HVAC Piping."
- B. Stop-Check Valves:
1. Manufacturers: Subject to compliance with requirements, available manufacturers offering products that may be incorporated into the Work include, but are not limited to, the following:
 - a. A.Y. McDonald Mfg. Co.
 - b. Cincinnati Valve Company.
 - c. Crane; Crane Energy Flow Solutions.
 - d. Jenkins Valves.
 2. Body and Bonnet: Malleable iron.
 3. End Connections: Flanged.
 4. Disc: Cylindrical with removable liner and machined seat.
 5. Stem: Brass alloy.
 6. Operator: Outside screw and yoke with cast-iron handwheel.
 7. Packing: Polytetrafluoroethylene-impregnated packing with two-piece packing gland assembly.
 8. Pressure Class: 250.

2.3 STRAINERS

- A. Y-Pattern Strainers:
1. Body: ASTM A 126, Class B cast iron, with bolted cover and bottom drain connection.

2. End Connections: Threaded ends for strainers NPS 2 and smaller; flanged ends for strainers NPS 2-1/2 and larger.
3. Strainer Screen: Stainless-steel, 20-mesh strainer, or perforated stainless-steel basket.
4. Tapped blowoff plug.
5. CWP Rating: 250-psig working steam pressure.

B. Basket Strainers:

1. Body: ASTM A 126, Class B cast iron, with bolted cover and bottom drain connection.
2. End Connections: Threaded ends for strainers NPS 2 and smaller; flanged ends for strainers NPS 2-1/2 and larger.
3. Strainer Screen: Stainless-steel, 20-mesh strainer, and perforated stainless-steel basket with 50 percent free area.
4. CWP Rating: 250-psig working steam pressure.

2.4 SAFETY VALVES

A. Bronze Safety Valves: ASME labeled.

1. Manufacturers: Subject to compliance with requirements, available manufacturers offering products that may be incorporated into the Work include, but are not limited to, the following:
 - a. Armstrong International, Inc.
 - b. Kunkle Valve.
 - c. Spirax Sarco, Inc.
 - d. Watts Regulator Co
2. Disc Material: Forged copper alloy.
3. End Connections: Threaded inlet and outlet.
4. Spring: Fully enclosed steel spring with adjustable pressure range and positive shutoff, factory set and sealed.
5. Pressure Class: 250.
6. Drip-Pan Elbow: Cast iron and having threaded inlet and outlet with threads complying with ASME B1.20.1.
7. Size and Capacity: As required for equipment according to ASME Boiler and Pressure Vessel Code.

B. Cast-Iron Safety Valves: ASME labeled.

1. Manufacturers: Subject to compliance with requirements, available manufacturers offering products that may be incorporated into the Work include, but are not limited to, the following:
 - a. Armstrong International, Inc.
 - b. Kunkle Valve.
 - c. Spirax Sarco, Inc.

d. Watts Regulator Co.

2. Disc Material: Forged copper alloy with bronze nozzle.
3. End Connections: Raised-face flanged inlet and threaded or flanged outlet connections.
4. Spring: Fully enclosed cadmium-plated steel spring with adjustable pressure range and positive shutoff, factory set and sealed.
5. Pressure Class: 250.
6. Drip-Pan Elbow: Cast iron and having threaded inlet, outlet, and drain, with threads complying with ASME B1.20.1.
7. Exhaust Head: Cast iron and having threaded inlet and drain, with threads complying with ASME B1.20.1.
8. Size and Capacity: As required for equipment according to ASME Boiler and Pressure Vessel Code.

2.5 STEAM TRAPS

A. Float and Thermostatic Traps:

1. Manufacturers: Subject to compliance with requirements, available manufacturers offering products that may be incorporated into the Work include, but are not limited to, the following:
 - a. Armstrong International, Inc.
 - b. Barnes & Jones, Inc.
 - c. Dunham-Bush, Inc.
 - d. Hoffman Specialty.
 - e. Spirax Sarco, Inc.
 - f. Sterling.
2. Body and Bolted Cap: ASTM A 126, cast iron.
3. End Connections: Threaded.
4. Float Mechanism: Replaceable, stainless steel.
5. Head and Seat: Hardened stainless steel.
6. Trap Type: Balanced pressure.
7. Thermostatic Bellows: Stainless steel or monel.
8. Thermostatic air vent capable of withstanding 45 deg F of superheat and resisting water hammer without sustaining damage.
9. Vacuum Breaker: Thermostatic with phosphor bronze bellows, and stainless-steel cage, valve, and seat.
10. Maximum Operating Pressure: 125 psig.

2.6 THERMOSTATIC AIR VENTS AND VACUUM BREAKERS

A. Vacuum Breakers:

1. Manufacturers: Subject to compliance with requirements, available manufacturers offering products that may be incorporated into the Work include, but are not limited to, the following:
 - a. Armstrong International, Inc.
 - b. Dunham-Bush, Inc.
 - c. Hoffman Specialty.
 - d. Johnson Corporation (The).
2. Body: Cast iron, bronze, or stainless steel.
3. End Connections: Threaded.
4. Sealing Ball, Retainer, Spring, and Screen: Stainless steel.
5. O-Ring Seal: EPR.
6. Pressure Rating: 300 psig.
7. Maximum Temperature Rating: 350 deg F.

PART 3 - EXECUTION

3.1 VALVE APPLICATIONS

- A. Install shutoff duty valves at branch connections to steam supply mains, at steam supply connections to equipment, and at the outlet of steam traps.
- B. Install safety valves on pressure-reducing stations and elsewhere as required by ASME Boiler and Pressure Vessel Code. Install safety-valve discharge piping, without valves, to nearest floor drain or as indicated on Drawings. Comply with ASME Boiler and Pressure Vessel Code: Section VIII, Division 1, for installation requirements.

3.2 PIPING INSTALLATION

- A. Install piping to permit valve servicing.
- B. Install drains, consisting of a tee fitting, NPS 3/4 full port-ball valve, and short NPS 3/4 threaded nipple with cap, at low points in piping system mains and elsewhere as required for system drainage.
- C. Install valves according to Section 230523 "General-Duty Valves for HVAC Piping."
- D. Install unions in piping, NPS 2 and smaller, adjacent to valves, at final connections of equipment, and elsewhere as indicated.
- E. Install flanges in piping, NPS 2-1/2 and larger, at final connections of equipment and elsewhere as indicated.
- F. Install shutoff valve immediately upstream of each dielectric fitting.

- G. Install strainers on supply side of control valves, pressure-reducing valves, traps, and elsewhere as indicated. Install NPS 3/4 nipple and full port ball valve in blowdown connection of strainers NPS 2 and larger. Match size of strainer blowoff connection for strainers smaller than NPS 2.

3.3 STEAM-TRAP INSTALLATION

- A. Install steam traps in accessible locations as close as possible to connected equipment.
- B. Install full-port ball valve, strainer, and union upstream from trap; install union, check valve, and full-port ball valve downstream from trap unless otherwise indicated.

3.4 SAFETY VALVE INSTALLATION

- A. Install safety valves according to ASME B31.1, "Power Piping"; and ASME B31.9, "Building Services Piping."
- B. Pipe safety-valve discharge without valves to atmosphere outside the building.
- C. Install drip-pan elbow fitting adjacent to safety valve and pipe drain connection to nearest floor drain.
- D. Install exhaust head with drain to waste, on vents equal to or larger than NPS 2-1/2.

3.5 EQUIPMENT CONNECTIONS

- A. Install traps and control valves in accessible locations close to connected equipment.
- B. Install bypass piping with globe valve around control valve. If parallel control valves are installed, only one bypass is required.
- C. Install vacuum breakers downstream from control valve, close to coil inlet connection.

END OF SECTION 232216

SECTION 233113

METAL DUCTS

PART 1 - GENERAL

1.1 RELATED DOCUMENTS

- A. Drawings and general provisions of the Contract, including General and Supplementary Conditions and Division 01 Specification Sections, apply to this Section.

1.2 SUMMARY

- A. Section Includes:

- 1. Single-wall rectangular ducts and fittings.
- 2. Single-wall round ducts and fittings.
- 3. Sheet metal materials.
- 4. Sealants and gaskets.
- 5. Hangers and supports.

- B. Related Sections:

- 1. Section 230593 "Testing, Adjusting, and Balancing for HVAC" for testing, adjusting, and balancing requirements for metal ducts.
- 2. Section 233300 "Air Duct Accessories" for dampers, sound-control devices, duct-mounting access doors and panels, turning vanes, and flexible ducts.

1.3 PERFORMANCE REQUIREMENTS

- A. Airstream Surfaces: Surfaces in contact with the airstream shall comply with requirements in ASHRAE 62.1.

1.4 ACTION SUBMITTALS

- A. Product Data: For each type of the following products:

- 1. Sealants and gaskets.

- B. Shop Drawings:

- 1. Fabrication, assembly, and installation, including plans, elevations, sections, components, and attachments to other work.
- 2. Factory- and shop-fabricated ducts and fittings.

3. Duct layout indicating sizes, configuration, liner material, and static-pressure classes.
4. Elevation of top of ducts.
5. Dimensions of main duct runs from building grid lines.
6. Fittings.
7. Reinforcement and spacing.
8. Seam and joint construction.
9. Penetrations through fire-rated and other partitions.
10. Equipment installation based on equipment being used on Project.
11. Locations for duct accessories, including dampers, turning vanes, and access doors and panels.
12. Hangers and supports, including methods for duct and building attachment and vibration isolation.

1.5 INFORMATIONAL SUBMITTALS

- A. Coordination Drawings: Plans, drawn to scale, on which the following items are shown and coordinated with each other, using input from installers of the items involved:
 1. Duct installation in congested spaces, indicating coordination with general construction, building components, and other building services. Indicate proposed changes to duct layout.
 2. Suspended ceiling components.
 3. Structural members to which duct will be attached.
 4. Size and location of initial access modules for acoustical tile.
 5. Penetrations of smoke barriers and fire-rated construction.
 6. Items penetrating finished ceiling including the following:
 - a. Lighting fixtures.
 - b. Air outlets and inlets.
 - c. Speakers.
 - d. Sprinklers.
 - e. Access panels.
- B. Welding certificates.
- C. Field quality-control reports.

1.6 QUALITY ASSURANCE

- A. Welding Qualifications: Qualify procedures and personnel according to the following:
 1. AWS D1.1/D1.1M, "Structural Welding Code - Steel," for hangers and supports.
 2. AWS D1.2/D1.2M, "Structural Welding Code - Aluminum," for aluminum supports.
 3. AWS D9.1M/D9.1, "Sheet Metal Welding Code," for duct joint and seam welding.

- B. ASHRAE Compliance: Applicable requirements in ASHRAE 62.1, Section 5 - "Systems and Equipment" and Section 7 - "Construction and System Start-up."
- C. ASHRAE/IESNA Compliance: Applicable requirements in ASHRAE/IESNA 90.1, Section 6.4.4 - "HVAC System Construction and Insulation."

PART 2 - PRODUCTS

2.1 SINGLE-WALL RECTANGULAR DUCTS AND FITTINGS

- A. General Fabrication Requirements: Comply with SMACNA's "HVAC Duct Construction Standards - Metal and Flexible" based on indicated static-pressure class unless otherwise indicated.
- B. Transverse Joints: Select joint types and fabricate according to SMACNA's "HVAC Duct Construction Standards - Metal and Flexible," Figure 2-1, "Rectangular Duct/Transverse Joints," for static-pressure class, applicable sealing requirements, materials involved, duct-support intervals, and other provisions in SMACNA's "HVAC Duct Construction Standards - Metal and Flexible."
- C. Longitudinal Seams: Select seam types and fabricate according to SMACNA's "HVAC Duct Construction Standards - Metal and Flexible," Figure 2-2, "Rectangular Duct/Longitudinal Seams," for static-pressure class, applicable sealing requirements, materials involved, duct-support intervals, and other provisions in SMACNA's "HVAC Duct Construction Standards - Metal and Flexible."
- D. Elbows, Transitions, Offsets, Branch Connections, and Other Duct Construction: Select types and fabricate according to SMACNA's "HVAC Duct Construction Standards - Metal and Flexible," Chapter 4, "Fittings and Other Construction," for static-pressure class, applicable sealing requirements, materials involved, duct-support intervals, and other provisions in SMACNA's "HVAC Duct Construction Standards - Metal and Flexible."

2.2 SINGLE-WALL ROUND DUCTS AND FITTINGS

- A. General Fabrication Requirements: Comply with SMACNA's "HVAC Duct Construction Standards - Metal and Flexible," Chapter 3, "Round, Oval, and Flexible Duct," based on indicated static-pressure class unless otherwise indicated.
 - 1. Manufacturers: Subject to compliance with requirements, available manufacturers offering products that may be incorporated into the Work include, but are not limited to, the following:
 - a. Lindab Inc.
 - b. McGill AirFlow LLC.
 - c. SEMCO Incorporated.
 - d. Sheet Metal Connectors, Inc.

e. Spiral Manufacturing Co., Inc.

- B. Transverse Joints: Select joint types and fabricate according to SMACNA's "HVAC Duct Construction Standards - Metal and Flexible," Figure 3-1, "Round Duct Transverse Joints," for static-pressure class, applicable sealing requirements, materials involved, duct-support intervals, and other provisions in SMACNA's "HVAC Duct Construction Standards - Metal and Flexible."
- C. Longitudinal Seams: Select seam types and fabricate according to SMACNA's "HVAC Duct Construction Standards - Metal and Flexible," Figure 3-2, "Round Duct Longitudinal Seams," for static-pressure class, applicable sealing requirements, materials involved, duct-support intervals, and other provisions in SMACNA's "HVAC Duct Construction Standards - Metal and Flexible."
- D. Tees and Laterals: Select types and fabricate according to SMACNA's "HVAC Duct Construction Standards - Metal and Flexible," Figure 3-5, "90 Degree Tees and Laterals," and Figure 3-6, "Conical Tees," for static-pressure class, applicable sealing requirements, materials involved, duct-support intervals, and other provisions in SMACNA's "HVAC Duct Construction Standards - Metal and Flexible."

2.3 SHEET METAL MATERIALS

- A. General Material Requirements: Comply with SMACNA's "HVAC Duct Construction Standards - Metal and Flexible" for acceptable materials, material thicknesses, and duct construction methods unless otherwise indicated. Sheet metal materials shall be free of pitting, seam marks, roller marks, stains, discolorations, and other imperfections.
- B. Galvanized Sheet Steel: Comply with ASTM A 653/A 653M.
 - 1. Galvanized Coating Designation: G60.
 - 2. Finishes for Surfaces Exposed to View: Mill phosphatized.
- C. Carbon-Steel Sheets: Comply with ASTM A 1008/A 1008M, with oiled, matte finish for exposed ducts.
- D. Stainless-Steel Sheets: Comply with ASTM A 480/A 480M, Type 304 or 316, as indicated in the "Duct Schedule" Article; cold rolled, annealed, sheet. Exposed surface finish shall be No. 2B, No. 2D, No. 3, or No. 4 as indicated in the "Duct Schedule" Article.
- E. Aluminum Sheets: Comply with ASTM B 209 Alloy 3003, H14 temper; with mill finish for concealed ducts, and standard, one-side bright finish for duct surfaces exposed to view.
- F. Factory- or Shop-Applied Antimicrobial Coating:
 - 1. Apply to the surface of sheet metal that will form the interior surface of the duct. An untreated clear coating shall be applied to the exterior surface.

2. Antimicrobial compound shall be tested for efficacy by an NRTL and registered by the EPA for use in HVAC systems.
 3. Coating containing the antimicrobial compound shall have a hardness of 2H, minimum, when tested according to ASTM D 3363.
 4. Surface-Burning Characteristics: Maximum flame-spread index of 25 and maximum smoke-developed index of 50 when tested according to UL 723; certified by an NRTL.
 5. Shop-Applied Coating Color: White.
 6. Antimicrobial coating on sheet metal is not required for duct containing liner treated with antimicrobial coating.
- G. Reinforcement Shapes and Plates: ASTM A 36/A 36M, steel plates, shapes, and bars; black and galvanized.
1. Where black- and galvanized-steel shapes and plates are used to reinforce aluminum ducts, isolate the different metals with butyl rubber, neoprene, or EPDM gasket materials.
- H. Tie Rods: Galvanized steel, 1/4-inch minimum diameter for lengths 36 inches or less; 3/8-inch minimum diameter for lengths longer than 36 inches.

2.4 SEALANT AND GASKETS

- A. General Sealant and Gasket Requirements: Surface-burning characteristics for sealants and gaskets shall be a maximum flame-spread index of 25 and a maximum smoke-developed index of 50 when tested according to UL 723; certified by an NRTL.
- B. Two-Part Tape Sealing System:
1. Tape: Woven cotton fiber impregnated with mineral gypsum and modified acrylic/silicone activator to react exothermically with tape to form hard, durable, airtight seal.
 2. Tape Width: 4 inches.
 3. Sealant: Modified styrene acrylic.
 4. Water resistant.
 5. Mold and mildew resistant.
 6. Maximum Static-Pressure Class: 10-inch wg, positive and negative.
 7. Service: Indoor and outdoor.
 8. Service Temperature: Minus 40 to plus 200 deg F.
 9. Substrate: Compatible with galvanized sheet steel (both PVC coated and bare), stainless steel, or aluminum.
 10. For indoor applications, sealant shall have a VOC content of 250 g/L or less when calculated according to 40 CFR 59, Subpart D (EPA Method 24).
 11. Sealant shall comply with the testing and product requirements of the California Department of Health Services' "Standard Practice for the Testing of Volatile Organic Emissions from Various Sources Using Small-Scale Environmental Chambers."
- C. Water-Based Joint and Seam Sealant:

1. Application Method: Brush on.
2. Solids Content: Minimum 65 percent.
3. Shore A Hardness: Minimum 20.
4. Water resistant.
5. Mold and mildew resistant.
6. VOC: Maximum 75 g/L (less water).
7. Maximum Static-Pressure Class: 10-inch wg, positive and negative.
8. Service: Indoor or outdoor.
9. Substrate: Compatible with galvanized sheet steel (both PVC coated and bare), stainless steel, or aluminum sheets.

D. Solvent-Based Joint and Seam Sealant:

1. Application Method: Brush on.
2. Base: Synthetic rubber resin.
3. Solvent: Toluene and heptane.
4. Solids Content: Minimum 60 percent.
5. Shore A Hardness: Minimum 60.
6. Water resistant.
7. Mold and mildew resistant.
8. For indoor applications, sealant shall have a VOC content of 250 g/L or less when calculated according to 40 CFR 59, Subpart D (EPA Method 24).
9. VOC: Maximum 395 g/L.
10. Sealant shall comply with the testing and product requirements of the California Department of Health Services' "Standard Practice for the Testing of Volatile Organic Emissions from Various Sources Using Small-Scale Environmental Chambers."
11. Maximum Static-Pressure Class: 10-inch wg, positive or negative.
12. Service: Indoor or outdoor.
13. Substrate: Compatible with galvanized sheet steel (both PVC coated and bare), stainless steel, or aluminum sheets.

E. Flanged Joint Sealant: Comply with ASTM C 920.

1. General: Single-component, acid-curing, silicone, elastomeric.
2. Type: S.
3. Grade: NS.
4. Class: 25.
5. Use: O.
6. For indoor applications, sealant shall have a VOC content of 250 g/L or less when calculated according to 40 CFR 59, Subpart D (EPA Method 24).
7. Sealant shall comply with the testing and product requirements of the California Department of Health Services' "Standard Practice for the Testing of Volatile Organic Emissions from Various Sources Using Small-Scale Environmental Chambers."

F. Flange Gaskets: Butyl rubber, neoprene, or EPDM polymer with polyisobutylene plasticizer.

G. Round Duct Joint O-Ring Seals:

1. Seal shall provide maximum leakage class of 3 cfm/100 sq. ft. at 1-inch wg and shall be rated for 10-inch wg static-pressure class, positive or negative.
2. EPDM O-ring to seal in concave bead in coupling or fitting spigot.
3. Double-lipped, EPDM O-ring seal, mechanically fastened to factory-fabricated couplings and fitting spigots.

2.5 HANGERS AND SUPPORTS

- A. Hanger Rods for Noncorrosive Environments: Cadmium-plated steel rods and nuts.
- B. Hanger Rods for Corrosive Environments: Electrogalvanized, all-thread rods or galvanized rods with threads painted with zinc-chromate primer after installation.
- C. Strap and Rod Sizes: Comply with SMACNA's "HVAC Duct Construction Standards - Metal and Flexible," Table 5-1, "Rectangular Duct Hangers Minimum Size," and Table 5-2, "Minimum Hanger Sizes for Round Duct."
- D. Steel Cables for Galvanized-Steel Ducts: Galvanized steel complying with ASTM A 603.
- E. Steel Cables for Stainless-Steel Ducts: Stainless steel complying with ASTM A 492.
- F. Steel Cable End Connections: Cadmium-plated steel assemblies with brackets, swivel, and bolts designed for duct hanger service; with an automatic-locking and clamping device.
- G. Duct Attachments: Sheet metal screws, blind rivets, or self-tapping metal screws; compatible with duct materials.
- H. Trapeze and Riser Supports:
 1. Supports for Galvanized-Steel Ducts: Galvanized-steel shapes and plates.
 2. Supports for Stainless-Steel Ducts: Stainless-steel shapes and plates.
 3. Supports for Aluminum Ducts: Aluminum or galvanized steel coated with zinc chromate.

PART 3 - EXECUTION

3.1 DUCT INSTALLATION

- A. Drawing plans, schematics, and diagrams indicate general location and arrangement of duct system. Indicated duct locations, configurations, and arrangements were used to size ducts and calculate friction loss for air-handling equipment sizing and for other design considerations. Install duct systems as indicated unless deviations to layout are approved on Shop Drawings and Coordination Drawings.

- B. Install ducts according to SMACNA's "HVAC Duct Construction Standards - Metal and Flexible" unless otherwise indicated.
- C. Install round ducts in maximum practical lengths.
- D. Install ducts with fewest possible joints.
- E. Install factory- or shop-fabricated fittings for changes in direction, size, and shape and for branch connections.
- F. Unless otherwise indicated, install ducts vertically and horizontally, and parallel and perpendicular to building lines.
- G. Install ducts close to walls, overhead construction, columns, and other structural and permanent enclosure elements of building.
- H. Install ducts with a clearance of 1 inch, plus allowance for insulation thickness.
- I. Route ducts to avoid passing through transformer vaults and electrical equipment rooms and enclosures.
- J. Where ducts pass through non-fire-rated interior partitions and exterior walls and are exposed to view, cover the opening between the partition and duct or duct insulation with sheet metal flanges of same metal thickness as the duct. Overlap openings on four sides by at least 1-1/2 inches.
- K. Where ducts pass through fire-rated interior partitions and exterior walls, install fire dampers. Comply with requirements in Section 233300 "Air Duct Accessories" for fire and smoke dampers.

3.2 INSTALLATION OF EXPOSED DUCTWORK

- A. Protect ducts exposed in finished spaces from being dented, scratched, or damaged.
- B. Trim duct sealants flush with metal. Create a smooth and uniform exposed bead. Do not use two-part tape sealing system.
- C. Grind welds to provide smooth surface free of burrs, sharp edges, and weld splatter. When welding stainless steel with a No. 3 or 4 finish, grind the welds flush, polish the exposed welds, and treat the welds to remove discoloration caused by welding.
- D. Maintain consistency, symmetry, and uniformity in the arrangement and fabrication of fittings, hangers and supports, duct accessories, and air outlets.
- E. Repair or replace damaged sections and finished work that does not comply with these requirements.

3.3 DUCT SEALING

- A. Seal ducts for duct static-pressure, seal classes, and leakage classes specified in "Duct Schedule" Article according to SMACNA's "HVAC Duct Construction Standards - Metal and Flexible."
- B. Seal ducts to the following seal classes according to SMACNA's "HVAC Duct Construction Standards - Metal and Flexible" and 2012 International Energy Conservation Code:
 - 1. Comply with SMACNA's "HVAC Duct Construction Standards - Metal and Flexible."
 - 2. Unconditioned Space, Exhaust Ducts: Seal Class B.
 - 3. Conditioned Space, Exhaust Ducts: Seal Class B.

3.4 HANGER AND SUPPORT INSTALLATION

- A. Comply with SMACNA's "HVAC Duct Construction Standards - Metal and Flexible," Chapter 5, "Hangers and Supports."
- B. Building Attachments: Concrete inserts, powder-actuated fasteners, or structural-steel fasteners appropriate for construction materials to which hangers are being attached.
 - 1. Where practical, install concrete inserts before placing concrete.
 - 2. Install powder-actuated concrete fasteners after concrete is placed and completely cured.
 - 3. Use powder-actuated concrete fasteners for standard-weight aggregate concretes or for slabs more than 4 inches thick.
 - 4. Do not use powder-actuated concrete fasteners for lightweight-aggregate concretes or for slabs less than 4 inches thick.
 - 5. Do not use powder-actuated concrete fasteners for seismic restraints.
- C. Hanger Spacing: Comply with SMACNA's "HVAC Duct Construction Standards - Metal and Flexible," Table 5-1, "Rectangular Duct Hangers Minimum Size," and Table 5-2, "Minimum Hanger Sizes for Round Duct," for maximum hanger spacing; install hangers and supports within 24 inches of each elbow and within 48 inches of each branch intersection.
- D. Hangers Exposed to View: Threaded rod and angle or channel supports.
- E. Support vertical ducts with steel angles or channel secured to the sides of the duct with welds, bolts, sheet metal screws, or blind rivets; support at each floor and at a maximum intervals of 16 feet.
- F. Install upper attachments to structures. Select and size upper attachments with pull-out, tension, and shear capacities appropriate for supported loads and building materials where used.

3.5 CONNECTIONS

- A. Make connections to equipment with flexible connectors complying with Section 233300 "Air Duct Accessories."
- B. Comply with SMACNA's "HVAC Duct Construction Standards - Metal and Flexible" for branch, outlet and inlet, and terminal unit connections.

3.6 PAINTING

- A. Paint interior of metal ducts that are visible through registers and grilles and that do not have duct liner. Apply one coat of flat, black, latex paint over a compatible galvanized-steel primer. Paint materials and application requirements are specified in Section 099113 "Exterior Painting" and Section 099123 "Interior Painting."

3.7 FIELD QUALITY CONTROL

- A. Perform tests and inspections.
- B. Leakage Tests:
 - 1. Comply with SMACNA's "HVAC Air Duct Leakage Test Manual." Submit a test report for each test.
 - 2. Test the following systems:
 - a. Exhaust Ducts with a Pressure Class of 2-Inch wg or Higher: Test representative duct sections, selected by Architect from sections installed, totaling no less than 50 percent of total installed duct area for each designated pressure class.
 - 3. Disassemble, reassemble, and seal segments of systems to accommodate leakage testing and for compliance with test requirements.
 - 4. Test for leaks before applying external insulation.
 - 5. Conduct tests at static pressures equal to maximum design pressure of system or section being tested. If static-pressure classes are not indicated, test system at maximum system design pressure. Do not pressurize systems above maximum design operating pressure.
 - 6. Give seven days' advance notice for testing.
- C. Duct System Cleanliness Tests:
 - 1. Visually inspect duct system to ensure that no visible contaminants are present.
 - 2. Test sections of metal duct system, chosen randomly by Owner, for cleanliness according to "Vacuum Test" in NADCA ACR, "Assessment, Cleaning and Restoration of HVAC Systems."
 - a. Acceptable Cleanliness Level: Net weight of debris collected on the filter media shall not exceed 0.75 mg/100 sq. cm.

- D. Duct system will be considered defective if it does not pass tests and inspections.
- E. Prepare test and inspection reports.

3.8 START UP

- A. Air Balance: Comply with requirements in Section 230593 "Testing, Adjusting, and Balancing for HVAC."

3.9 DUCT SCHEDULE

- A. Fabricate ducts with galvanized sheet steel except as otherwise indicated and as follows:
- B. Exhaust Ducts:
 - 1. Ducts Connected to Fans Exhausting (ASHRAE 62.1, Class 1 and 2) Air:
 - a. Pressure Class: Negative 2-inch wg.
 - b. Minimum SMACNA Seal Class: B if negative pressure, and A if positive pressure.
 - c. SMACNA Leakage Class for Rectangular: 8.
 - d. SMACNA Leakage Class for Round: 4.
- C. Intermediate Reinforcement:
 - 1. Galvanized-Steel Ducts: Galvanized steel.
- D. Elbow Configuration:
 - 1. Rectangular Duct: Comply with SMACNA's "HVAC Duct Construction Standards - Metal and Flexible," Figure 4-2, "Rectangular Elbows."
 - a. Velocity 1000 fpm or Lower:
 - 1) Radius Type RE 1 with minimum 0.5 radius-to-diameter ratio.
 - 2) Mitered Type RE 4 without vanes.
 - b. Velocity 1000 to 1500 fpm:
 - 1) Radius Type RE 1 with minimum 1.0 radius-to-diameter ratio.
 - 2) Radius Type RE 3 with minimum 0.5 radius-to-diameter ratio and two vanes.
 - 3) Mitered Type RE 2 with vanes complying with SMACNA's "HVAC Duct Construction Standards - Metal and Flexible," Figure 4-3, "Vanes and Vane Runners," and Figure 4-4, "Vane Support in Elbows."
 - c. Velocity 1500 fpm or Higher:

- 1) Radius Type RE 1 with minimum 1.5 radius-to-diameter ratio.
 - 2) Radius Type RE 3 with minimum 1.0 radius-to-diameter ratio and two vanes.
 - 3) Mitered Type RE 2 with vanes complying with SMACNA's "HVAC Duct Construction Standards - Metal and Flexible," Figure 4-3, "Vanes and Vane Runners," and Figure 4-4, "Vane Support in Elbows."
2. Rectangular Duct: Comply with SMACNA's "HVAC Duct Construction Standards - Metal and Flexible," Figure 4-2, "Rectangular Elbows."
 - a. Radius Type RE 1 with minimum 1.5 radius-to-diameter ratio.
 - b. Radius Type RE 3 with minimum 1.0 radius-to-diameter ratio and two vanes.
 - c. Mitered Type RE 2 with vanes complying with SMACNA's "HVAC Duct Construction Standards - Metal and Flexible," Figure 4-3, "Vanes and Vane Runners," and Figure 4-4, "Vane Support in Elbows."
 3. Round Duct: Comply with SMACNA's "HVAC Duct Construction Standards - Metal and Flexible," Figure 3-4, "Round Duct Elbows."
 - a. Minimum Radius-to-Diameter Ratio and Elbow Segments: Comply with SMACNA's "HVAC Duct Construction Standards - Metal and Flexible," Table 3-1, "Mitered Elbows." Elbows with less than 90-degree change of direction have proportionately fewer segments.
 - 1) Velocity 1000 fpm or Lower: 0.5 radius-to-diameter ratio and three segments for 90-degree elbow.
 - 2) Velocity 1000 to 1500 fpm: 1.0 radius-to-diameter ratio and four segments for 90-degree elbow.
 - 3) Velocity 1500 fpm or Higher: 1.5 radius-to-diameter ratio and five segments for 90-degree elbow.
 - 4) Radius-to Diameter Ratio: 1.5.
 - b. Round Elbows, 12 Inches and Smaller in Diameter: Stamped or pleated.
 - c. Round Elbows, 14 Inches and Larger in Diameter: Standing seam.
- E. Branch Configuration:
1. Rectangular Duct: Comply with SMACNA's "HVAC Duct Construction Standards - Metal and Flexible," Figure 4-6, "Branch Connection."
 - a. Rectangular Main to Rectangular Branch: 45-degree entry.
 - b. Rectangular Main to Round Branch: Spin in.
 2. Round: Comply with SMACNA's "HVAC Duct Construction Standards - Metal and Flexible," Figure 3-5, "90 Degree Tees and Laterals," and Figure 3-6, "Conical Tees." Saddle taps are permitted in existing duct.
 - a. Velocity 1000 fpm or Lower: 90-degree tap.

- b. Velocity 1000 to 1500 fpm: Conical tap.
- c. Velocity 1500 fpm or Higher: 45-degree lateral.

END OF SECTION 233113

SECTION 233300

AIR DUCT ACCESSORIES

PART 1 - GENERAL

1.1 RELATED DOCUMENTS

- A. Drawings and general provisions of the Contract, including General and Supplementary Conditions and Division 01 Specification Sections, apply to this Section.

1.2 SUMMARY

- A. Section Includes:
 - 1. Backdraft and pressure relief dampers.
 - 2. Manual volume dampers.
 - 3. Fire dampers.
 - 4. Flange connectors.
 - 5. Turning vanes.
 - 6. Duct-mounted access doors.
 - 7. Flexible connectors.
 - 8. Duct security bars.
 - 9. Duct accessory hardware.

1.3 ACTION SUBMITTALS

- A. Shop Drawings: For duct accessories. Include plans, elevations, sections, details and attachments to other work.
 - 1. Detail duct accessories fabrication and installation in ducts and other construction. Include dimensions, weights, loads, and required clearances; and method of field assembly into duct systems and other construction. Include the following:
 - a. Special fittings.
 - b. Manual volume damper installations.
 - c. Control-damper installations.
 - d. Fire-damper, smoke-damper, combination fire- and smoke-damper, ceiling, and corridor damper installations, including sleeves; and duct-mounted access doors and remote damper operators.
 - e. Duct security bars.
 - f. Wiring Diagrams: For power, signal, and control wiring.

1.4 INFORMATIONAL SUBMITTALS

- A. Coordination Drawings: Reflected ceiling plans, drawn to scale, on which ceiling-mounted access panels and access doors required for access to duct accessories are shown and coordinated with each other, using input from Installers of the items involved.
- B. Source quality-control reports.

1.5 CLOSEOUT SUBMITTALS

- A. Operation and Maintenance Data: For air duct accessories to include in operation and maintenance manuals.

1.6 MAINTENANCE MATERIAL SUBMITTALS

- A. Furnish extra materials that match products installed and that are packaged with protective covering for storage and identified with labels describing contents.
 - 1. Fusible Links: Furnish quantity equal to 10 percent of amount installed.

PART 2 - PRODUCTS

2.1 ASSEMBLY DESCRIPTION

- A. Comply with NFPA 90A, "Installation of Air Conditioning and Ventilating Systems," and with NFPA 90B, "Installation of Warm Air Heating and Air Conditioning Systems."
- B. Comply with SMACNA's "HVAC Duct Construction Standards - Metal and Flexible" for acceptable materials, material thicknesses, and duct construction methods unless otherwise indicated. Sheet metal materials shall be free of pitting, seam marks, roller marks, stains, discolorations, and other imperfections.

2.2 MATERIALS

- A. Galvanized Sheet Steel: Comply with ASTM A 653/A 653M.
 - 1. Galvanized Coating Designation: G90.
 - 2. Exposed-Surface Finish: Mill phosphatized.
- B. Aluminum Sheets: Comply with ASTM B 209, Alloy 3003, Temper H14; with mill finish for concealed ducts and standard, 1-side bright finish for exposed ducts.
- C. Extruded Aluminum: Comply with ASTM B 221, Alloy 6063, Temper T6.

- D. Reinforcement Shapes and Plates: Galvanized-steel reinforcement where installed on galvanized sheet metal ducts; compatible materials for aluminum and stainless-steel ducts.
- E. Tie Rods: Galvanized steel, 1/4-inch minimum diameter for lengths 36 inches or less; 3/8-inch minimum diameter for lengths longer than 36 inches.

2.3 BACKDRAFT AND PRESSURE RELIEF DAMPERS

- A. Manufacturers: Subject to compliance with requirements, available manufacturers offering products that may be incorporated into the Work include, but are not limited to, the following:
 - 1. Air Balance Inc.; a division of Mestek, Inc.
 - 2. American Warming and Ventilating; a division of Mestek, Inc.
 - 3. Cesco Products; a division of Mestek, Inc.
 - 4. Greenheck Fan Corporation.
 - 5. Lloyd Industries, Inc.
 - 6. Nailor Industries Inc.
 - 7. NCA Manufacturing, Inc.
 - 8. Pottorff.
 - 9. Ruskin Company.
 - 10. Vent Products Company, Inc.
- B. Description: Gravity balanced.
- C. Maximum Air Velocity: 2000 fpm.
- D. Maximum System Pressure: 2-inch wg.
- E. Frame: Hat-shaped, 0.094-inch-thick, galvanized sheet steel, with welded corners or mechanically attached and mounting flange.
- F. Blades: Multiple single-piece blades, center pivoted, maximum 6-inch width, 0.025-inch-thick, roll-formed aluminum with sealed edges.
- G. Blade Action: Parallel.
- H. Blade Seals: Neoprene, mechanically locked.
- I. Blade Axles:
 - 1. Material: Galvanized steel.
 - 2. Diameter: 0.20 inch.
- J. Tie Bars and Brackets: Galvanized steel.
- K. Return Spring: Adjustable tension.

L. Bearings: Synthetic pivot bushings.

M. Accessories:

1. Adjustment device to permit setting for varying differential static pressure.
2. Counterweights and spring-assist kits for vertical airflow installations.
3. Electric actuators.
4. 90-degree stops.

2.4 MANUAL VOLUME DAMPERS

A. Standard, Steel, Manual Volume Dampers:

1. Manufacturers: Subject to compliance with requirements, available manufacturers offering products that may be incorporated into the Work include, but are not limited to, the following:
 - a. Air Balance Inc.; a division of Mestek, Inc.
 - b. American Warming and Ventilating; a division of Mestek, Inc.
 - c. Flexmaster U.S.A., Inc.
 - d. McGill AirFlow LLC.
 - e. Nailor Industries Inc.
 - f. Pottorff.
 - g. Ruskin Company.
 - h. Trox USA Inc.
 - i. Vent Products Company, Inc.
2. Standard leakage rating, with linkage outside airstream.
3. Suitable for horizontal or vertical applications.
4. Frames:
 - a. Frame: Hat-shaped, 0.094-inch-thick, galvanized sheet steel.
 - b. Mitered and welded corners.
 - c. Flanges for attaching to walls and flangeless frames for installing in ducts.
5. Blades:
 - a. Multiple or single blade.
 - b. Parallel- or opposed-blade design.
 - c. Stiffen damper blades for stability.
 - d. Galvanized-steel, 0.064 inch thick.
6. Blade Axles: Galvanized steel.
7. Bearings:
 - a. Molded synthetic.
 - b. Dampers in ducts with pressure classes of 3-inch wg or less shall have axles full length of damper blades and bearings at both ends of operating shaft.

8. Tie Bars and Brackets: Galvanized steel.

B. Damper Hardware:

1. Zinc-plated, die-cast core with dial and handle made of 3/32-inch-thick zinc-plated steel, and a 3/4-inch hexagon locking nut.
2. Include center hole to suit damper operating-rod size.
3. Include elevated platform for insulated duct mounting.

2.5 FIRE DAMPERS

A. Manufacturers: Subject to compliance with requirements, available manufacturers offering products that may be incorporated into the Work include, but are not limited to, the following:

1. Air Balance Inc.; a division of Mestek, Inc.
2. Arrow United Industries; a division of Mestek, Inc.
3. Cesco Products; a division of Mestek, Inc.
4. Greenheck Fan Corporation.
5. Nailor Industries Inc.
6. NCA Manufacturing, Inc.
7. Pottorff.
8. Prefco; Perfect Air Control, Inc.
9. Ruskin Company.
10. Vent Products Company, Inc.
11. Ward Industries, Inc.; a division of Hart & Cooley, Inc.

B. Type: Static and dynamic; rated and labeled according to UL 555 by an NRTL.

C. Closing rating in ducts up to 4-inch wg static pressure class and minimum 2000-fpm velocity.

D. Fire Rating: 1-1/2 hours.

E. Frame: Curtain type with blades inside airstream; fabricated with roll-formed, 0.034-inch-thick galvanized steel; with mitered and interlocking corners.

F. Mounting Sleeve: Factory- or field-installed, galvanized sheet steel.

1. Minimum Thickness: 0.138 inch or 0.39 inch thick, as indicated, and of length to suit application.
2. Exception: Omit sleeve where damper-frame width permits direct attachment of perimeter mounting angles on each side of wall or floor; thickness of damper frame must comply with sleeve requirements.

G. Mounting Orientation: Vertical or horizontal as indicated.

- H. Blades: Roll-formed, interlocking, 0.034-inch-thick, galvanized sheet steel. In place of interlocking blades, use full-length, 0.034-inch-thick, galvanized-steel blade connectors.
- I. Horizontal Dampers: Include blade lock and stainless-steel closure spring.
- J. Heat-Responsive Device: Replaceable, 165 deg F rated, fusible links.

2.6 FLANGE CONNECTORS

- A. Manufacturers: Subject to compliance with requirements, available manufacturers offering products that may be incorporated into the Work include, but are not limited to, the following:
 - 1. Ductmate Industries, Inc.
 - 2. Nexus PDQ; Division of Shilco Holdings Inc.
 - 3. Ward Industries, Inc.; a division of Hart & Cooley, Inc.
- B. Description: Add-on or roll-formed, factory-fabricated, slide-on transverse flange connectors, gaskets, and components.
- C. Material: Galvanized steel.
- D. Gage and Shape: Match connecting ductwork.

2.7 TURNING VANES

- A. Manufacturers: Subject to compliance with requirements, available manufacturers offering products that may be incorporated into the Work include, but are not limited to, the following:
 - 1. Ductmate Industries, Inc.
 - 2. Duro Dyne Inc.
 - 3. Elgen Manufacturing.
 - 4. METALAIRE, Inc.
 - 5. SEMCO Incorporated.
 - 6. Ward Industries, Inc.; a division of Hart & Cooley, Inc.
- B. Manufactured Turning Vanes for Metal Ducts: Curved blades of galvanized sheet steel; support with bars perpendicular to blades set; set into vane runners suitable for duct mounting.
 - 1. Acoustic Turning Vanes: Fabricate airfoil-shaped aluminum extrusions with perforated faces and fibrous-glass fill.
- C. Manufactured Turning Vanes for Nonmetal Ducts: Fabricate curved blades of resin-bonded fiberglass with acrylic polymer coating; support with bars perpendicular to blades set; set into vane runners suitable for duct mounting.

- D. General Requirements: Comply with SMACNA's "HVAC Duct Construction Standards - Metal and Flexible"; Figures 4-3, "Vaness and Vane Runners," and 4-4, "Vane Support in Elbows."
- E. Vane Construction: Single wall.

2.8 DUCT-MOUNTED ACCESS DOORS

- A. Manufacturers: Subject to compliance with requirements, available manufacturers offering products that may be incorporated into the Work include, but are not limited to, the following:
 - 1. American Warming and Ventilating; a division of Mestek, Inc.
 - 2. Cesco Products; a division of Mestek, Inc.
 - 3. Ductmate Industries, Inc.
 - 4. Elgen Manufacturing.
 - 5. Flexmaster U.S.A., Inc.
 - 6. Greenheck Fan Corporation.
 - 7. McGill AirFlow LLC.
 - 8. Nailor Industries Inc.
 - 9. Pottorff.
 - 10. Ventfabrics, Inc.
 - 11. Ward Industries, Inc.; a division of Hart & Cooley, Inc.
- B. Duct-Mounted Access Doors: Fabricate access panels according to SMACNA's "HVAC Duct Construction Standards - Metal and Flexible"; Figures 7-2, "Duct Access Doors and Panels," and 7-3, "Access Doors - Round Duct."
 - 1. Door:
 - a. Double wall, rectangular.
 - b. Galvanized sheet metal with insulation fill and thickness as indicated for duct pressure class.
 - c. Vision panel.
 - d. Hinges and Latches: 1-by-1-inchbutt or piano hinge and cam latches.
 - e. Fabricate doors airtight and suitable for duct pressure class.
 - 2. Frame: Galvanized sheet steel, with bend-over tabs and foam gaskets.
 - 3. Number of Hinges and Locks:
 - a. Access Doors Less Than 12 Inches Square: No hinges and two sash locks.
 - b. Access Doors up to 18 Inches Square: Continuous and two sash locks.

2.9 FLEXIBLE CONNECTORS

- A. Manufacturers: Subject to compliance with requirements, available manufacturers offering products that may be incorporated into the Work include, but are not limited to, the following:

1. Ductmate Industries, Inc.
 2. Duro Dyne Inc.
 3. Elgen Manufacturing.
 4. Ventfabrics, Inc.
 5. Ward Industries, Inc.; a division of Hart & Cooley, Inc.
- B. Materials: Flame-retardant or noncombustible fabrics.
- C. Coatings and Adhesives: Comply with UL 181, Class 1.
- D. Metal-Edged Connectors: Factory fabricated with a fabric strip 3-1/2 inches wide attached to two strips of 2-3/4-inch-wide, 0.028-inch-thick, galvanized sheet steel or 0.032-inch-thick aluminum sheets. Provide metal compatible with connected ducts.
- E. Indoor System, Flexible Connector Fabric: Glass fabric double coated with neoprene.
1. Minimum Weight: 26 oz./sq. yd..
 2. Tensile Strength: 480 lbf/inch in the warp and 360 lbf/inch in the filling.
 3. Service Temperature: Minus 40 to plus 200 deg F.

2.10 DUCT SECURITY BARS

- A. Manufacturers: Subject to compliance with requirements, available manufacturers offering products that may be incorporated into the Work include, but are not limited to, the following:
1. Carnes.
 2. KEES, Inc.
 3. Lloyd Industries, Inc.
 4. Metal Form Manufacturing, Inc.
 5. Price Industries.
- B. Description: Field- or factory-fabricated and field-installed duct security bars.
- C. Configuration:
1. Frame: 2-1/2 by 2-1/2 by 1/4 inch angle.
 2. Sleeve: 3/16-inch, continuously welded steel frames with 1-1/2-by-1-1/2-by-1/8-inch angle frame factory welded to 1 end. To be poured in place or set with concrete block or welded or bolted to wall, one side only. Duct connections on both sides.
 3. Horizontal Bars: 1/2 inch.
 4. Vertical Bars: 1/2 inch.
 5. Bar Spacing: 6 inches.
 6. Mounting: Ductwork or other framing.

2.11 DUCT ACCESSORY HARDWARE

- A. Instrument Test Holes: Cast iron or cast aluminum to suit duct material, including screw cap and gasket. Size to allow insertion of pitot tube and other testing instruments and of length to suit duct-insulation thickness.
- B. Adhesives: High strength, quick setting, neoprene based, waterproof, and resistant to gasoline and grease.

PART 3 - EXECUTION

3.1 INSTALLATION

- A. Install duct accessories according to applicable details in SMACNA's "HVAC Duct Construction Standards - Metal and Flexible" for metal ducts.
- B. Install duct accessories of materials suited to duct materials; use galvanized-steel accessories in galvanized-steel and fibrous-glass ducts, stainless-steel accessories in stainless-steel ducts, and aluminum accessories in aluminum ducts.
- C. Install backdraft dampers at inlet of exhaust fans or exhaust ducts as close as possible to exhaust fan unless otherwise indicated.
- D. Install volume dampers at points on supply, return, and exhaust systems where branches extend from larger ducts. Where dampers are installed in ducts having duct liner, install dampers with hat channels of same depth as liner, and terminate liner with nosing at hat channel.
 - 1. Install steel volume dampers in steel ducts.
 - 2. Install aluminum volume dampers in aluminum ducts.
- E. Set dampers to fully open position before testing, adjusting, and balancing.
- F. Install test holes at fan inlets and outlets and elsewhere as indicated.
- G. Install fire dampers according to UL listing.
- H. Install duct security bars. Construct duct security bars from 0.164-inch steel sleeve, continuously welded at all joints and 1/2-inch-diameter steel bars, 6 inches o.c. in each direction in center of sleeve. Weld each bar to steel sleeve and each crossing bar. Weld 2-1/2-by-2-1/2-by-1/4-inch steel angle to 4 sides and both ends of sleeve. Connect duct security bars to ducts with flexible connections. Provide 12-by-12-inch hinged access panel with cam lock in duct in each side of sleeve.
- I. Install duct access doors on sides of ducts to allow for inspecting, adjusting, and maintaining accessories and equipment at the following locations:
 - 1. Downstream from manual volume dampers, control dampers, backdraft dampers, and equipment.

2. Adjacent to and close enough to fire, to reset or reinstall fusible links. Access doors for access to fire dampers having fusible links shall be pressure relief access doors and shall be outward operation for access doors installed upstream from dampers and inward operation for access doors installed downstream from dampers.
 3. Control devices requiring inspection.
 4. Downstream from security bars.
 5. Elsewhere as indicated.
- J. Install access doors with swing against duct static pressure.
- K. Access Door Sizes:
1. Two-Hand Access: 12 by 6 inches.
 2. Head and Hand Access: 18 by 10 inches.
- L. Label access doors according to Section 230553 "Identification for HVAC Piping and Equipment" to indicate the purpose of access door.
- M. Install flexible connectors to connect ducts to equipment.
- N. Install duct test holes where required for testing and balancing purposes.

3.2 FIELD QUALITY CONTROL

- A. Tests and Inspections:
1. Operate dampers to verify full range of movement.
 2. Inspect locations of access doors and verify that purpose of access door can be performed.
 3. Operate fire dampers to verify full range of movement and verify that proper heat-response device is installed.
 4. Inspect turning vanes for proper and secure installation.

END OF SECTION 233300

SECTION 233423

HVAC POWER VENTILATORS

PART 1 - GENERAL

1.1 RELATED DOCUMENTS

- A. Drawings and general provisions of the Contract, including General and Supplementary Conditions and Division 01 Specification Sections, apply to this Section.

1.2 SUMMARY

- A. Section Includes:
 - 1. In-line centrifugal fans.

1.3 PERFORMANCE REQUIREMENTS

- A. Project Altitude: Base fan-performance ratings on actual Project site elevations.
- B. Operating Limits: Classify according to AMCA 99.

1.4 ACTION SUBMITTALS

- A. Product Data: For each type of product indicated. Include rated capacities, operating characteristics, and furnished specialties and accessories. Also include the following:
 - 1. Certified fan performance curves with system operating conditions indicated.
 - 2. Certified fan sound-power ratings.
 - 3. Motor ratings and electrical characteristics, plus motor and electrical accessories.
 - 4. Material thickness and finishes, including color charts.
 - 5. Dampers, including housings, linkages, and operators.
 - 6. Roof curbs.
 - 7. Fan speed controllers.
- B. Shop Drawings: Include plans, elevations, sections, details, and attachments to other work.
 - 1. Detail equipment assemblies and indicate dimensions, weights, loads, required clearances, method of field assembly, components, and location and size of each field connection.
 - 2. Wiring Diagrams: For power, signal, and control wiring.

1.5 CLOSEOUT SUBMITTALS

- A. Operation and Maintenance Data: For power ventilators to include in emergency, operation, and maintenance manuals.

1.6 MAINTENANCE MATERIAL SUBMITTALS

- A. Furnish extra materials that match products installed and that are packaged with protective covering for storage and identified with labels describing contents.

1.7 QUALITY ASSURANCE

- A. Electrical Components, Devices, and Accessories: Listed and labeled as defined in NFPA 70, by a qualified testing agency, and marked for intended location and application.
- B. AMCA Compliance: Fans shall have AMCA-Certified performance ratings and shall bear the AMCA-Certified Ratings Seal.
- C. UL Standards: Power ventilators shall comply with UL 705. Power ventilators for use for restaurant kitchen exhaust shall also comply with UL 762.

1.8 COORDINATION

- A. Coordinate size and location of structural-steel support members.
- B. Coordinate sizes and locations of concrete bases with actual equipment provided.
- C. Coordinate sizes and locations of roof curbs, equipment supports, and roof penetrations with actual equipment provided.

PART 2 - PRODUCTS

2.1 IN-LINE CENTRIFUGAL FANS

- A. Manufacturers: Subject to compliance with requirements, available manufacturers offering products that may be incorporated into the Work include, but are not limited to, the following:
 - 1. Acme Engineering & Manufacturing Corporation.
 - 2. American Coolair Corporation.
 - 3. Ammerman; Millennium Equipment.
 - 4. Breidert Air Products.
 - 5. Carnes Company.
 - 6. FloAire.
 - 7. Greenheck Fan Corporation.

8. Hartzell Fan Incorporated.
 9. JencoFan.
 10. Loren Cook Company.
 11. Madison Manufacturing.
 12. PennBarry.
 13. Quietaire Inc.
- B. Housing: Aluminum with aluminum straightening vanes, inlet and outlet flanges, and support bracket adaptable to floor, side wall, or ceiling mounting.
- C. Direct-Drive Units: Motor mounted in airstream, factory wired to disconnect switch located on outside of fan housing; with wheel, inlet cone, and motor on swing-out service door.
- D. Fan Wheels: Aluminum, airfoil blades welded to aluminum hub.
- E. Accessories:
1. Variable-Speed Controller: Solid-state control to reduce speed from 100 to less than 50 percent.
 2. Volume-Control Damper: Manually operated with quadrant lock, located in fan outlet.
 3. Companion Flanges: For inlet and outlet duct connections.
 4. Fan Guards: 1/2- by 1-inch mesh of galvanized steel in removable frame. Provide guard for inlet or outlet for units not connected to ductwork.
 5. Motor and Drive Cover (Belt Guard): Epoxy-coated steel.
- F. Capacities and Characteristics: See Equipment Schedule on drawings.

2.2 MOTORS

- A. Comply with NEMA designation, temperature rating, service factor, enclosure type, and efficiency requirements for motors specified in Section 230513 "Common Motor Requirements for HVAC Equipment."
1. Motor Sizes: Minimum size as indicated. If not indicated, large enough so driven load will not require motor to operate in service factor range above 1.0.
- B. Enclosure Type: Totally enclosed, fan cooled.

2.3 SOURCE QUALITY CONTROL

- A. Certify sound-power level ratings according to AMCA 301, "Methods for Calculating Fan Sound Ratings from Laboratory Test Data." Factory test fans according to AMCA 300, "Reverberant Room Method for Sound Testing of Fans." Label fans with the AMCA-Certified Ratings Seal.

- B. Certify fan performance ratings, including flow rate, pressure, power, air density, speed of rotation, and efficiency by factory tests according to AMCA 210, "Laboratory Methods of Testing Fans for Aerodynamic Performance Rating." Label fans with the AMCA-Certified Ratings Seal.

PART 3 - EXECUTION

3.1 INSTALLATION

- A. Install power ventilators level and plumb.
- B. Ceiling Units: Suspend units from structure; use steel wire or metal straps.
- C. Support suspended units from structure using threaded steel rods and elastomeric hangers having a static deflection of 1 inch. Vibration-control devices are specified in Section 230553 "Identification for HVAC Piping and Equipment." Install units with clearances for service and maintenance.
- D. Label units according to requirements specified in Section 230553 "Identification for HVAC Piping and Equipment."

3.2 CONNECTIONS

- A. Drawings indicate general arrangement of ducts and duct accessories. Make final duct connections with flexible connectors. Flexible connectors are specified in Section 233300 "Air Duct Accessories."
- B. Install ducts adjacent to power ventilators to allow service and maintenance.
- C. Ground equipment according to Section 260526 "Grounding and Bonding for Electrical Systems."
- D. Connect wiring according to Section 260519 "Low-Voltage Electrical Power Conductors and Cables."

3.3 FIELD QUALITY CONTROL

- A. Perform tests and inspections.
 - 1. Manufacturer's Field Service: Engage a factory-authorized service representative to inspect components, assemblies, and equipment installations, including connections, and to assist in testing.
- B. Tests and Inspections:
 - 1. Verify that shipping, blocking, and bracing are removed.
 - 2. Verify that unit is secure on mountings and supporting devices and that connections to ducts and electrical components are complete. Verify that proper

- thermal-overload protection is installed in motors, starters, and disconnect switches.
3. Verify that cleaning and adjusting are complete.
 4. Disconnect fan drive from motor, verify proper motor rotation direction, and verify fan wheel free rotation and smooth bearing operation. Reconnect fan drive system, align and adjust belts, and install belt guards.
 5. Adjust belt tension.
 6. Adjust damper linkages for proper damper operation.
 7. Verify lubrication for bearings and other moving parts.
 8. Verify that manual and automatic volume control and fire and smoke dampers in connected ductwork systems are in fully open position.
 9. Disable automatic temperature-control operators, energize motor and adjust fan to indicated rpm, and measure and record motor voltage and amperage.
 10. Shut unit down and reconnect automatic temperature-control operators.
 11. Remove and replace malfunctioning units and retest as specified above.
- C. Test and adjust controls and safeties. Replace damaged and malfunctioning controls and equipment.
- D. Prepare test and inspection reports.

3.4 ADJUSTING

- A. Adjust damper linkages for proper damper operation.
- B. Adjust belt tension.
- C. Comply with requirements in Section 230593 "Testing, Adjusting, and Balancing for HVAC" for testing, adjusting, and balancing procedures.
- D. Replace fan and motor pulleys as required to achieve design airflow.
- E. Lubricate bearings.

END OF SECTION 233423

SECTION 233713

DIFFUSERS, REGISTERS, AND GRILLES

PART 1 - GENERAL

1.1 RELATED DOCUMENTS

- A. Drawings and general provisions of the Contract, including General and Supplementary Conditions and Division 01 Specification Sections, apply to this Section.

1.2 SUMMARY

- A. Section Includes:
 - 1. Fixed face registers.
- B. Related Sections:
 - 1. Section 233300 "Air Duct Accessories" for fire and smoke dampers and volume-control dampers not integral to diffusers, registers, and grilles.

1.3 ACTION SUBMITTALS

- A. Product Data: For each type of product indicated, include the following:
 - 1. Data Sheet: Indicate materials of construction, finish, and mounting details; and performance data including throw and drop, static-pressure drop, and noise ratings.
 - 2. Diffuser, Register, and Grille Schedule: Indicate drawing designation, room location, quantity, model number, size, and accessories furnished.
- B. Samples for Initial Selection: For diffusers, registers, and grilles with factory-applied color finishes.
- C. Samples for Verification: For diffusers, registers, and grilles, in manufacturer's standard sizes to verify color selected.

1.4 INFORMATIONAL SUBMITTALS

- A. Coordination Drawings: Reflected ceiling plans, drawn to scale, on which the following items are shown and coordinated with each other, using input from Installers of the items involved:

1. Ceiling suspension assembly members.
2. Method of attaching hangers to building structure.
3. Size and location of initial access modules for acoustical tile.
4. Ceiling-mounted items including lighting fixtures, diffusers, grilles, speakers, sprinklers, access panels, and special moldings.
5. Duct access panels.

- B. Source quality-control reports.

PART 2 - PRODUCTS

2.1 REGISTERS

- A. Fixed Face Register:

1. Manufacturers: Subject to compliance with requirements, available manufacturers offering products that may be incorporated into the Work include, but are not limited to, the following:
 - a. A-J Manufacturing Co., Inc.
 - b. Anemostat Products; a Mestek company.
 - c. Carnes.
 - d. Dayus Register & Grille Inc.
 - e. Hart & Cooley Inc.
 - f. Krueger.
 - g. Nailor Industries Inc.
 - h. Price Industries.
 - i. Titus.
 - j. Tuttle & Bailey.
2. Material: Aluminum.
3. Finish: Baked enamel, white.
4. Face Arrangement: 1/2-by-1/2-by-1/2-inch grid core.
5. Core Construction: Removable.
6. Frame: 1-1/4 inches wide.
7. Mounting: Countersunk screw.
8. Damper Type: Adjustable opposed blade.
9. Accessory: Filter.

2.2 SOURCE QUALITY CONTROL

- A. Verification of Performance: Rate diffusers, registers, and grilles according to ASHRAE 70, "Method of Testing for Rating the Performance of Air Outlets and Inlets."

PART 3 - EXECUTION

3.1 EXAMINATION

- A. Examine areas where diffusers, registers, and grilles are to be installed for compliance with requirements for installation tolerances and other conditions affecting performance of equipment.
- B. Proceed with installation only after unsatisfactory conditions have been corrected.

3.2 INSTALLATION

- A. Install registers level and plumb.
- B. Install registers with airtight connections to ducts and to allow service and maintenance of dampers, air extractors, and fire dampers.

3.3 ADJUSTING

- A. After installation, adjust diffusers, registers, and grilles to air patterns indicated, or as directed, before starting air balancing.

END OF SECTION 233713

SECTION 260519

LOW-VOLTAGE ELECTRICAL POWER CONDUCTORS AND CABLES

PART 1 - GENERAL

1.1 RELATED DOCUMENTS

- A. Drawings and general provisions of the Contract, including General and Supplementary Conditions and Division 01 Specification Sections, apply to this Section.

1.2 SUMMARY

- A. Section Includes:
 - 1. Building wires and cables rated 600 V and less.
 - 2. Connectors, splices, and terminations rated 600 V and less.

1.3 ACTION SUBMITTALS

- A. Product Data: For each type of product.

1.4 INFORMATIONAL SUBMITTALS

- A. Qualification Data: For testing agency.
- B. Field quality-control reports.

1.5 QUALITY ASSURANCE

- A. Testing Agency Qualifications: Member company of NETA or an NRTL.
 - 1. Testing Agency's Field Supervisor: Certified by NETA to supervise on-site testing.

PART 2 - PRODUCTS

2.1 CONDUCTORS AND CABLES

- A. Manufacturers: Subject to compliance with requirements, provide products by one of the following available manufacturers offering products that may be incorporated into the Work include, but are not limited to, the following:
 - 1. Alpha Wire
 - 2. General Cable Technologies Corporation
 - 3. Southwire Incorporated
- B. Copper Conductors: Comply with NEMA WC 70/ICEA S-95-658.
- C. Conductor Insulation: Comply with NEMA WC 70/ICEA S-95-658 for Type THHN/THWN-2.
- D. Multiconductor Cable: Comply with NEMA WC 70/ICEA S-95-658 for metal-clad cable, Type MC with ground wire.

2.2 CONNECTORS AND SPLICES

- A. Manufacturers: Subject to compliance with requirements, provide products by one of the following available manufacturers offering products that may be incorporated into the Work include, but are not limited to, the following:
 - 1. AFC Cable Systems, Inc.
 - 2. Hubbell Power Systems, Inc.
 - 3. 3M
- B. Description: Factory-fabricated connectors and splices of size, ampacity rating, material, type, and class for application and service indicated.

2.3 SYSTEM DESCRIPTION

- A. Electrical Components, Devices, and Accessories: Listed and labeled as defined in NFPA 70, by a qualified testing agency, and marked for intended location and application.
- B. Comply with NFPA 70.

PART 3 - EXECUTION

3.1 CONDUCTOR MATERIAL APPLICATIONS

- A. Feeders: Copper. Solid for No. 10 AWG and smaller; stranded for No. 8 AWG and larger.

- B. Branch Circuits: Copper. Solid for No. 10 AWG and smaller; stranded for No. 8 AWG and larger, except VFC cable, which shall be extra flexible stranded.

3.2 CONDUCTOR INSULATION AND MULTICONDUCTOR CABLE APPLICATIONS AND WIRING METHODS

- A. Exposed Feeders: Type XHHW-2, single conductors in raceway.
- B. Feeders Concealed in Ceilings, Walls, Partitions, and Crawlspace: Type THHN/THWN-2, single conductors in raceway.
- C. Exposed Branch Circuits, Including in Crawlspace: Type THHN/THWN-2, single conductors in raceway.

3.3 INSTALLATION OF CONDUCTORS AND CABLES

- A. Complete raceway installation between conductor and cable termination points according to Section 260533 "Raceways and Boxes for Electrical Systems" prior to pulling conductors and cables.
- B. Use manufacturer-approved pulling compound or lubricant where necessary; compound used must not deteriorate conductor or insulation. Do not exceed manufacturer's recommended maximum pulling tensions and sidewall pressure values.
- C. Use pulling means, including fish tape, cable, rope, and basket-weave wire/cable grips, that will not damage cables or raceway.
- D. Install exposed cables parallel and perpendicular to surfaces of exposed structural members, and follow surface contours where possible.
- E. Support cables according to Section 260529 "Hangers and Supports for Electrical Systems."

3.4 CONNECTIONS

- A. Tighten electrical connectors and terminals according to manufacturer's published torque-tightening values. If manufacturer's torque values are not indicated, use those specified in UL 486A-486B.
- B. Make splices, terminations, and taps that are compatible with conductor material and that possess equivalent or better mechanical strength and insulation ratings than unspliced conductors.
 - 1. Use oxide inhibitor in each splice, termination, and tap for aluminum conductors.
- C. Wiring at Outlets: Install conductor at each outlet, with at least 6 inches of slack.

3.5 IDENTIFICATION

- A. Identify and color-code conductors and cables according to Section 260553 "Identification for Electrical Systems."
- B. Identify each spare conductor at each end with identity number and location of other end of conductor, and identify as spare conductor.

3.6 SLEEVE AND SLEEVE-SEAL INSTALLATION FOR ELECTRICAL PENETRATIONS

- A. Install sleeves and sleeve seals at penetrations of exterior floor and wall assemblies. Comply with requirements in Section 260544 "Sleeves and Sleeve Seals for Electrical Raceways and Cabling."

3.7 FIRESTOPPING

- A. Apply firestopping to electrical penetrations of fire-rated floor and wall assemblies to restore original fire-resistance rating of assembly according to Section 078413 "Penetration Firestopping."

3.8 FIELD QUALITY CONTROL

- A. Testing Agency: Engage a qualified testing agency to perform tests and inspections.
- B. Perform the following tests and inspections with the assistance of a factory-authorized service representative:
 - 1. After installing conductors and cables and before electrical circuitry has been energized, test service entrance and feeder conductors and conductors feeding the following critical equipment and services for compliance with requirements.
 - a. Distribution Panels.
 - b. Fan Motors.
 - 2. Perform each visual and mechanical inspection and electrical test stated in NETA Acceptance Testing Specification. Certify compliance with test parameters.
- C. Test and Inspection Reports: Prepare a written report to record the following:
 - 1. Procedures used.
 - 2. Results that comply with requirements.
 - 3. Results that do not comply with requirements and corrective action taken to achieve compliance with requirements.
- D. Cables will be considered defective if they do not pass tests and inspections.

END OF SECTION 260519

SECTION 260526

GROUNDING AND BONDING FOR ELECTRICAL SYSTEMS

PART 1 - GENERAL

1.1 RELATED DOCUMENTS

- A. Drawings and general provisions of the Contract, including General and Supplementary Conditions and Division 01 Specification Sections, apply to this Section.

1.2 ACTION SUBMITTALS

- A. Product Data: For each type of product indicated.

1.3 INFORMATIONAL SUBMITTALS

- A. Qualification Data: For testing agency and testing agency's field supervisor.
- B. Field quality-control reports.

1.4 QUALITY ASSURANCE

- A. Testing Agency Qualifications: Member company of NETA or an NRTL.
 - 1. Testing Agency's Field Supervisor: Certified by NETA to supervise on-site testing.
- B. Electrical Components, Devices, and Accessories: Listed and labeled as defined in NFPA 70, by a qualified testing agency, and marked for intended location and application.
- C. Comply with UL 467 for grounding and bonding materials and equipment.

PART 2 - PRODUCTS

2.1 MANUFACTURERS

- A. Manufacturers: Subject to compliance with requirements, provide products by one of the following available manufacturers offering products that may be incorporated into the Work include, but are not limited to, the following:
 - 1. Burndy; Part of Hubbell Electrical Systems

2. ERICO International Corporation
3. Siemens Power Transmission & Distribution, Inc.

2.2 SYSTEM DESCRIPTION

- A. Electrical Components, Devices, and Accessories: Listed and labeled as defined in NFPA 70, by a qualified testing agency, and marked for intended location and application.
- B. Comply with UL 467 for grounding and bonding materials and equipment.

2.3 CONDUCTORS

- A. Insulated Conductors: Copper or tinned-copper wire or cable insulated for 600 V unless otherwise required by applicable Code or authorities having jurisdiction.
- B. Bare Copper Conductors:
 1. Solid Conductors: ASTM B 3.
 2. Stranded Conductors: ASTM B 8.
 3. Tinned Conductors: ASTM B 33.
 4. Bonding Cable: 28 kcmil, 14 strands of No. 17 AWG conductor, 1/4 inch in diameter.
 5. Bonding Conductor: No. 4 or No. 6 AWG, stranded conductor.
 6. Bonding Jumper: Copper tape, braided conductors terminated with copper ferrules; 1-5/8 inches wide and 1/16 inch thick.
 7. Tinned Bonding Jumper: Tinned-copper tape, braided conductors terminated with copper ferrules; 1-5/8 inches wide and 1/16 inch thick.

2.4 CONNECTORS

- A. Listed and labeled by an NRTL acceptable to authorities having jurisdiction for applications in which used and for specific types, sizes, and combinations of conductors and other items connected.
- B. Bolted Connectors for Conductors and Pipes: Copper or copper alloy.
- C. Bus-Bar Connectors: Mechanical type, cast silicon bronze, solderless compression-type wire terminals, and long-barrel, two-bolt connection to ground bus bar.

PART 3 - EXECUTION

3.1 APPLICATIONS

- A. Conductors: Install solid conductor for No. 8 AWG and smaller, and stranded conductors for No. 6 AWG and larger unless otherwise indicated.

B. Conductor Terminations and Connections:

1. Equipment Grounding Conductor Terminations: Bolted connectors.
2. Connections to Structural Steel: Welded connectors.

3.2 EQUIPMENT GROUNDING

A. Install insulated equipment grounding conductors with all feeders and branch circuits.

B. Install insulated equipment grounding conductors with the following items, in addition to those required by NFPA 70:

1. Feeders and branch circuits.
2. Single-phase motor and appliance branch circuits.
3. Three-phase motor and appliance branch circuits.
4. Flexible raceway runs.
5. Metal-clad cable runs.

C. Air-Duct Equipment Circuits: Install insulated equipment grounding conductor to duct-mounted electrical devices operating at 120 V and more, including air cleaners, heaters, dampers, humidifiers, and other duct electrical equipment. Bond conductor to each unit and to air duct and connected metallic piping.

3.3 INSTALLATION

A. Grounding Conductors: Route along shortest and straightest paths possible unless otherwise indicated or required by Code. Avoid obstructing access or placing conductors where they may be subjected to strain, impact, or damage.

B. Bonding Straps and Jumpers: Install in locations accessible for inspection and maintenance except where routed through short lengths of conduit.

1. Bonding to Structure: Bond straps directly to basic structure, taking care not to penetrate any adjacent parts.
2. Bonding to Equipment Mounted on Vibration Isolation Hangers and Supports: Install bonding so vibration is not transmitted to rigidly mounted equipment.

C. Bonding Interior Metal Ducts: Bond metal air ducts to equipment grounding conductors of associated fans, blowers, electric heaters, and air cleaners. Install tinned bonding jumper to bond across flexible duct connections to achieve continuity.

3.4 FIELD QUALITY CONTROL

A. Testing Agency: Engage a qualified testing agency to perform tests and inspections.

B. Tests and Inspections:

1. After installing grounding system but before permanent electrical circuits have been energized, test for compliance with requirements.
 2. Inspect physical and mechanical condition. Verify tightness of accessible, bolted, electrical connections with a calibrated torque wrench according to manufacturer's written instructions.
- C. Grounding system will be considered defective if it does not pass tests and inspections.
- D. Prepare test and inspection reports.

END OF SECTION 260526

SECTION 260529

HANGERS AND SUPPORTS FOR ELECTRICAL SYSTEMS

PART 1 - GENERAL

1.1 RELATED DOCUMENTS

- A. Drawings and general provisions of the Contract, including General and Supplementary Conditions and Division 01 Specification Sections, apply to this Section.

1.2 SUMMARY

- A. This Section includes the following:
 - 1. Hangers and supports for electrical equipment and systems.
 - 2. Construction requirements for concrete bases.

1.3 DEFINITIONS

- A. EMT: Electrical metallic tubing.
- B. RMC: Rigid metal conduit.

1.4 PERFORMANCE REQUIREMENTS

- A. Design supports for multiple raceways capable of supporting combined weight of supported systems and its contents.
- B. Design equipment supports capable of supporting combined operating weight of supported equipment and connected systems and components.
- C. Rated Strength: Adequate in tension, shear, and pullout force to resist maximum loads calculated or imposed for this Project, with a minimum structural safety factor of five times the applied force.

1.5 ACTION SUBMITTALS

- A. Product Data: For the following:
 - 1. Steel slotted support systems.

- B. Shop Drawings: Show fabrication and installation details and include calculations for the following:
 - 1. Trapeze hangers. Include Product Data for components.
 - 2. Steel slotted channel systems. Include Product Data for components.
 - 3. Equipment supports.

1.6 INFORMATIONAL SUBMITTALS

- A. Welding certificates.

1.7 QUALITY ASSURANCE

- A. Comply with NFPA 70.

PART 2 - PRODUCTS

2.1 SUPPORT, ANCHORAGE, AND ATTACHMENT COMPONENTS

- A. Steel Slotted Support Systems: Comply with MFMA-4, factory-fabricated components for field assembly.
 - 1. Manufacturers: Subject to compliance with requirements, provide products by one of the following available manufacturers offering products that may be incorporated into the Work include, but are not limited to, the following:
 - a. Allied Tube & Conduit
 - b. Cooper B-Line, Inc.
 - c. Thomas & Betts Corporation.
 - 2. Metallic Coatings: Hot-dip galvanized after fabrication and applied according to MFMA-4.
 - 3. Painted Coatings: Manufacturer's standard painted coating applied according to MFMA-4.
 - 4. Channel Dimensions: Selected for applicable load criteria.
- B. Raceway and Cable Supports: As described in NECA 1 and NECA 101.
- C. Conduit and Cable Support Devices: Steel and malleable-iron hangers, clamps, and associated fittings, designed for types and sizes of raceway or cable to be supported.
- D. Structural Steel for Fabricated Supports and Restraints: ASTM A 36/A 36M, steel plates, shapes, and bars; black and galvanized.
- E. Mounting, Anchoring, and Attachment Components: Items for fastening electrical items or their supports to building surfaces include the following:

1. Powder-Actuated Fasteners: Threaded-steel stud, for use in hardened portland cement concrete, steel, or wood, with tension, shear, and pullout capacities appropriate for supported loads and building materials where used.
 - a. Manufacturers: Subject to compliance with requirements, provide products by one of the following available manufacturers offering products that may be incorporated into the Work include, but are not limited to, the following:
 - 1) Hilti, Inc.
 - 2) MKT Fastening, LLC.
 - 3) Simpson Strong-Tie Co., Inc.
2. Mechanical-Expansion Anchors: Insert-wedge-type, zinc-coated steel, for use in hardened portland cement concrete with tension, shear, and pullout capacities appropriate for supported loads and building materials in which used.
 - a. Manufacturers: Subject to compliance with requirements, provide products by one of the following available manufacturers offering products that may be incorporated into the Work include, but are not limited to, the following:
 - 1) Cooper B-Line, Inc.
 - 2) Hilti, Inc.
 - 3) MKT Fastening, LLC.
3. Concrete Inserts: Steel or malleable-iron, slotted support system units similar to MSS Type 18; complying with MFMA-4 or MSS SP-58.
4. Clamps for Attachment to Steel Structural Elements: MSS SP-58, type suitable for attached structural element.
5. Through Bolts: Structural type, hex head, and high strength. Comply with ASTM A 325.
6. Toggle Bolts: All-steel springhead type.
7. Hanger Rods: Threaded steel.

2.2 FABRICATED METAL EQUIPMENT SUPPORT ASSEMBLIES

- A. Description: Welded or bolted, structural-steel shapes, shop or field fabricated to fit dimensions of supported equipment.
- B. Materials: Comply with requirements in Section 055000 "Metal Fabrications" for steel shapes and plates.

PART 3 - EXECUTION

3.1 APPLICATION

- A. Comply with NECA 1 and NECA 101 for application of hangers and supports for electrical equipment and systems except if requirements in this Section are stricter.
- B. Maximum Support Spacing and Minimum Hanger Rod Size for Raceway: Space supports for EMT, IMC, and RMC as required by NFPA 70. Minimum rod size shall be 1/4 inch in diameter.

- C. Multiple Raceways or Cables: Install trapeze-type supports fabricated with steel slotted support system, sized so capacity can be increased by at least 25 percent in future without exceeding specified design load limits.
 - 1. Secure raceways and cables to these supports with two-bolt conduit clamps.
- D. Spring-steel clamps designed for supporting single conduits without bolts may be used for 1-1/2-inch and smaller raceways serving branch circuits and communication systems above suspended ceilings and for fastening raceways to trapeze supports.

3.2 SUPPORT INSTALLATION

- A. Comply with NECA 1 and NECA 101 for installation requirements except as specified in this Article.
- B. Raceway Support Methods: In addition to methods described in NECA 1, EMT, IMC, and RMC may be supported by openings through structure members, as permitted in NFPA 70.
- C. Strength of Support Assemblies: Where not indicated, select sizes of components so strength will be adequate to carry present and future static loads within specified loading limits. Minimum static design load used for strength determination shall be weight of supported components plus 200 lb.
- D. Mounting and Anchorage of Surface-Mounted Equipment and Components: Anchor and fasten electrical items and their supports to building structural elements by the following methods unless otherwise indicated by code:
 - 1. To Wood: Fasten with lag screws or through bolts.
 - 2. To New Concrete: Bolt to concrete inserts.
 - 3. To Masonry: Approved toggle-type bolts on hollow masonry units and expansion anchor fasteners on solid masonry units.
 - 4. To Existing Concrete: Expansion anchor fasteners.
 - 5. Instead of expansion anchors, powder-actuated driven threaded studs provided with lock washers and nuts may be used in existing standard-weight concrete 4 inches thick or greater. Do not use for anchorage to lightweight-aggregate concrete or for slabs less than 4 inches thick.
 - 6. To Steel: Beam clamps (MSS Type 19, 21, 23, 25, or 27) complying with MSS SP-69.
 - 7. To Light Steel: Sheet metal screws.
 - 8. Items Mounted on Hollow Walls and Nonstructural Building Surfaces: Mount cabinets, panelboards, disconnect switches, control enclosures, pull and junction boxes, transformers, and other devices on slotted-channel racks attached to substrate.
- E. Drill holes for expansion anchors in concrete at locations and to depths that avoid reinforcing bars.

3.3 PAINTING

- A. Touchup: Clean field welds and abraded areas of shop paint. Paint exposed areas immediately after erecting hangers and supports. Use same materials as used for shop painting. Comply with SSPC-PA 1 requirements for touching up field-painted surfaces.
 - 1. Apply paint by brush or spray to provide minimum dry film thickness of 2.0 mils.
- B. Touchup: Comply with requirements in Section 099123 "Interior Painting" and Section 099600 "High Performance Coatings" for cleaning and touchup painting of field welds, bolted connections, and abraded areas of shop paint on miscellaneous metal.
- C. Galvanized Surfaces: Clean welds, bolted connections, and abraded areas and apply galvanizing-repair paint to comply with ASTM A 780.

END OF SECTION 260529

SECTION 260533

RACEWAYS AND BOXES FOR ELECTRICAL SYSTEMS

PART 1 - GENERAL

1.1 RELATED DOCUMENTS

- A. Drawings and general provisions of the Contract, including General and Supplementary Conditions and Division 01 Specification Sections, apply to this Section.

1.2 SUMMARY

- A. Section Includes:
 - 1. Metal conduits, tubing, and fittings.
 - 2. Surface raceways.
 - 3. Boxes, enclosures, and cabinets.

1.3 DEFINITIONS

- A. GRC: Galvanized rigid steel conduit.
- B. IMC: Intermediate metal conduit.

1.4 ACTION SUBMITTALS

- A. Product Data: For surface raceways, wireways and fittings, floor boxes, hinged-cover enclosures, and cabinets.

1.5 INFORMATIONAL SUBMITTALS

- A. Coordination Drawings: Conduit routing plans, drawn to scale, on which the following items are shown and coordinated with each other, using input from installers of items involved:
 - 1. Structural members in paths of conduit groups with common supports.
 - 2. HVAC and plumbing items and architectural features in paths of conduit groups with common supports.
- B. Source quality-control reports.

PART 2 - PRODUCTS

2.1 METAL CONDUITS, TUBING, AND FITTINGS

- A. Manufacturers: Subject to compliance with requirements, provide products by one of the following available manufacturers offering products that may be incorporated into the Work include, but are not limited to, the following:
 - 1. Allied Tube & Conduit
 - 2. Southwire Company
 - 3. Thomas & Betts Corporation
- B. Listing and Labeling: Metal conduits, tubing, and fittings shall be listed and labeled as defined in NFPA 70, by a qualified testing agency, and marked for intended location and application.
- C. GRC: Comply with ANSI C80.1 and UL 6.
- D. ARC: Comply with ANSI C80.5 and UL 6A.
- E. IMC: Comply with ANSI C80.6 and UL 1242.
- F. EMT: Comply with ANSI C80.3 and UL 797.
- G. FMC: Comply with UL 1; zinc-coated steel.
- H. LFMC: Flexible steel conduit with PVC jacket and complying with UL 360.
- I. Fittings for Metal Conduit: Comply with NEMA FB 1 and UL 514B.
 - 1. Conduit Fittings for Hazardous (Classified) Locations: Comply with UL 886 and NFPA 70.
 - 2. Fittings for EMT:
 - a. Material: Steel or die cast.
 - b. Type: Compression.
- J. Joint Compound for IMC, GRC, or ARC: Approved, as defined in NFPA 70, by authorities having jurisdiction for use in conduit assemblies, and compounded for use to lubricate and protect threaded conduit joints from corrosion and to enhance their conductivity.

2.2 BOXES, ENCLOSURES, AND CABINETS

- A. Manufacturers: Subject to compliance with requirements, provide products by one of the following available manufacturers offering products that may be incorporated into the Work include, but are not limited to, the following:
 - 1. Hubbell Incorporated.
 - 2. Thomas & Betts Corporation.

3. Wiremold / Legrand

- B. General Requirements for Boxes, Enclosures, and Cabinets: Boxes, enclosures, and cabinets installed in wet locations shall be listed for use in wet locations.
- C. Sheet Metal Outlet and Device Boxes: Comply with NEMA OS 1 and UL 514A.
- D. Cast-Metal Outlet and Device Boxes: Comply with NEMA FB 1, ferrous alloy, Type FD, with gasketed cover.
- E. Luminaire Outlet Boxes: Nonadjustable, designed for attachment of luminaire weighing 50 lb. Outlet boxes designed for attachment of luminaires weighing more than 50 lb shall be listed and marked for the maximum allowable weight.
- F. Small Sheet Metal Pull and Junction Boxes: NEMA OS 1.
- G. Box extensions used to accommodate new building finishes shall be of same material as recessed box.
- H. Device Box Dimensions: 4 inches square by 2-1/8 inches deep.
- I. Gangable boxes are allowed.
- J. Hinged-Cover Enclosures: Comply with UL 50 and NEMA 250, Type 1 with continuous-hinge cover with flush latch unless otherwise indicated.
 - 1. Metal Enclosures: Steel, finished inside and out with manufacturer's standard enamel.
 - 2. Interior Panels: Steel; all sides finished with manufacturer's standard enamel.
- K. Cabinets:
 - 1. NEMA 250, Type 1 galvanized-steel box with removable interior panel and removable front, finished inside and out with manufacturer's standard enamel.
 - 2. Hinged door in front cover with flush latch and concealed hinge.
 - 3. Key latch to match panelboards.
 - 4. Metal barriers to separate wiring of different systems and voltage.
 - 5. Accessory feet where required for freestanding equipment.

PART 3 - EXECUTION

3.1 RACEWAY APPLICATION

- A. Outdoors: Apply raceway products as specified below unless otherwise indicated:
 - 1. Exposed Conduit: GRC.
 - 2. Concealed Conduit, Aboveground: EMT.

3. Connection to Vibrating Equipment (Including Transformers and Hydraulic, Pneumatic, Electric Solenoid, or Motor-Driven Equipment): LFMC.
 4. Boxes and Enclosures, Aboveground: NEMA 250, Type 3R.
- B. Indoors: Apply raceway products as specified below unless otherwise indicated:
1. Exposed, Not Subject to Physical Damage: EMT.
 2. Exposed, Not Subject to Severe Physical Damage: IMC.
 3. Exposed and Subject to Severe Physical Damage: GRC. Raceway locations include the following:
 - a. Corridors used for traffic of mechanized carts, forklifts, and pallet-handling units.
 - b. Mechanical rooms.
 4. Concealed in Ceilings and Interior Walls and Partitions: EMT.
 5. Connection to Vibrating Equipment (Including Transformers and Hydraulic, Pneumatic, Electric Solenoid, or Motor-Driven Equipment): FMC, except use LFMC in damp or wet locations.
 6. Damp or Wet Locations: GRC.
 7. Boxes and Enclosures: NEMA 250, Type 1, except use NEMA 250, Type 4 stainless steel in institutional and commercial kitchens and damp or wet locations.
- C. Minimum Raceway Size: 3/4-inch trade size.
- D. Raceway Fittings: Compatible with raceways and suitable for use and location.
1. Rigid and Intermediate Steel Conduit: Use threaded rigid steel conduit fittings unless otherwise indicated. Comply with NEMA FB 2.10.
 2. EMT: Use compression, steel fittings. Comply with NEMA FB 2.10.
 3. Flexible Conduit: Use only fittings listed for use with flexible conduit. Comply with NEMA FB 2.20.
- E. Install nonferrous conduit or tubing for circuits operating above 60 Hz. Where aluminum raceways are installed for such circuits and pass through concrete, install in nonmetallic sleeve.
- F. Do not install aluminum conduits, boxes, or fittings in contact with concrete or earth.
- G. Install surface raceways only where indicated on Drawings.
- H. Do not install nonmetallic conduit where ambient temperature exceeds 120 deg F.
- 3.2 INSTALLATION
- A. Comply with NECA 1 and NECA 101 for installation requirements except where requirements on Drawings or in this article are stricter. Comply with NECA 102 for aluminum conduits. Comply with NFPA 70 limitations for types of raceways allowed in specific occupancies and number of floors.

- B. Keep raceways at least 6 inches away from parallel runs of flues and steam or hot-water pipes. Install horizontal raceway runs above water and steam piping.
- C. Complete raceway installation before starting conductor installation.
- D. Comply with requirements in Section 260529 "Hangers and Supports for Electrical Systems" for hangers and supports.
- E. Arrange stub-ups so curved portions of bends are not visible above finished slab.
- F. Install no more than the equivalent of three 90-degree bends in any conduit run except for control wiring conduits, for which fewer bends are allowed. Support within 12 inches of changes in direction.
- G. Conceal conduit and EMT within finished walls, ceilings, and floors unless otherwise indicated. Install conduits parallel or perpendicular to building lines.
- H. Support conduit within 12 inches of enclosures to which attached.
- I. Raceways Embedded in Slabs:
 - 1. Run conduit larger than 1-inch trade size, parallel or at right angles to main reinforcement. Where at right angles to reinforcement, place conduit close to slab support. Secure raceways to reinforcement at maximum 10-foot intervals.
 - 2. Arrange raceways to cross building expansion joints at right angles with expansion fittings.
 - 3. Arrange raceways to keep a minimum of 1 inch of concrete cover in all directions.
 - 4. Do not embed threadless fittings in concrete unless specifically approved by Architect for each specific location.
 - 5. Change from ENT to GRC or IMC before rising above floor.
- J. Stub-ups to Above Recessed Ceilings:
 - 1. Use EMT, IMC, or RMC for raceways.
 - 2. Use a conduit bushing or insulated fitting to terminate stub-ups not terminated in hubs or in an enclosure.
- K. Threaded Conduit Joints, Exposed to Wet, Damp, Corrosive, or Outdoor Conditions: Apply listed compound to threads of raceway and fittings before making up joints. Follow compound manufacturer's written instructions.
- L. Coat field-cut threads on PVC-coated raceway with a corrosion-preventing conductive compound prior to assembly.
- M. Raceway Terminations at Locations Subject to Moisture or Vibration: Use insulating bushings to protect conductors including conductors smaller than No. 4 AWG.
- N. Terminate threaded conduits into threaded hubs or with locknuts on inside and outside of boxes or cabinets. Install bushings on conduits up to 1-1/4-inch trade size and

insulated throat metal bushings on 1-1/2-inch trade size and larger conduits terminated with locknuts. Install insulated throat metal grounding bushings on service conduits.

- O. Install raceways square to the enclosure and terminate at enclosures with locknuts. Install locknuts hand tight plus 1/4 turn more.
- P. Do not rely on locknuts to penetrate nonconductive coatings on enclosures. Remove coatings in the locknut area prior to assembling conduit to enclosure to assure a continuous ground path.
- Q. Cut conduit perpendicular to the length. For conduits 2-inch trade size and larger, use roll cutter or a guide to make cut straight and perpendicular to the length.
- R. Install pull wires in empty raceways. Use polypropylene or monofilament plastic line with not less than 200-lb tensile strength. Leave at least 12 inches of slack at each end of pull wire. Cap underground raceways designated as spare above grade alongside raceways in use.
- S. Surface Raceways:
 - 1. Install surface raceway with a minimum 2-inch radius control at bend points.
 - 2. Secure surface raceway with screws or other anchor-type devices at intervals not exceeding 48 inches and with no less than two supports per straight raceway section. Support surface raceway according to manufacturer's written instructions. Tape and glue are not acceptable support methods.
- T. Install raceway sealing fittings at accessible locations according to NFPA 70 and fill them with listed sealing compound. For concealed raceways, install each fitting in a flush steel box with a blank cover plate having a finish similar to that of adjacent plates or surfaces. Install raceway sealing fittings according to NFPA 70.
- U. Install devices to seal raceway interiors at accessible locations. Locate seals so no fittings or boxes are between the seal and the following changes of environments. Seal the interior of all raceways at the following points:
 - 1. Where conduits pass from warm to cold locations, such as boundaries of refrigerated spaces.
 - 2. Where an underground service raceway enters a building or structure.
 - 3. Where otherwise required by NFPA 70.
- V. Comply with manufacturer's written instructions for solvent welding RNC and fittings.
- W. Flexible Conduit Connections: Comply with NEMA RV 3. Use a maximum of 72 inches of flexible conduit for equipment subject to vibration, noise transmission, or movement; and for transformers and motors.
 - 1. Use LFMC in damp or wet locations subject to severe physical damage.
 - 2. Use LFMC in damp or wet locations not subject to severe physical damage.

- X. Mount boxes at heights indicated on Drawings. If mounting heights of boxes are not individually indicated, give priority to ADA requirements. Install boxes with height measured to center of box unless otherwise indicated.
- Y. Recessed Boxes in Masonry Walls: Saw-cut opening for box in center of cell of masonry block, and install box flush with surface of wall. Prepare block surfaces to provide a flat surface for a raintight connection between box and cover plate or supported equipment and box.
- Z. Horizontally separate boxes mounted on opposite sides of walls so they are not in the same vertical channel.
- AA. Locate boxes so that cover or plate will not span different building finishes.
- BB. Support boxes of three gangs or more from more than one side by spanning two framing members or mounting on brackets specifically designed for the purpose.
- CC. Fasten junction and pull boxes to or support from building structure. Do not support boxes by conduits.
- DD. Set metal floor boxes level and flush with finished floor surface.

3.3 SLEEVE AND SLEEVE-SEAL INSTALLATION FOR ELECTRICAL PENETRATIONS

- A. Install sleeves and sleeve seals at penetrations of exterior floor and wall assemblies. Comply with requirements in Section 260544 "Sleeves and Sleeve Seals for Electrical Raceways and Cabling."

3.4 FIRESTOPPING

- A. Install firestopping at penetrations of fire-rated floor and wall assemblies. Comply with requirements in Section 078413 "Penetration Firestopping."

3.5 PROTECTION

- A. Protect coatings, finishes, and cabinets from damage and deterioration.
 - 1. Repair damage to galvanized finishes with zinc-rich paint recommended by manufacturer.

END OF SECTION 260533

SECTION 260544

SLEEVES AND SLEEVE SEALS FOR ELECTRICAL RACEWAYS AND CABLING

PART 1 - GENERAL

1.1 RELATED DOCUMENTS

- A. Drawings and general provisions of the Contract, including General and Supplementary Conditions and Division 01 Specification Sections, apply to this Section.

1.2 SUMMARY

- A. Section Includes:

- 1. Sleeves for raceway and cable penetration of non-fire-rated construction walls and floors.
- 2. Sleeve-seal systems.
- 3. Sleeve-seal fittings.
- 4. Grout.
- 5. Silicone sealants.

- B. Related Requirements:

- 1. Section 078413 "Penetration Firestopping" for penetration firestopping installed in fire-resistance-rated walls, horizontal assemblies, and smoke barriers, with and without penetrating items.

1.3 ACTION SUBMITTALS

- A. Product Data: For each type of product.

PART 2 - PRODUCTS

2.1 SLEEVES

- A. Wall Sleeves:

- 1. Steel Pipe Sleeves: ASTM A 53/A 53M, Type E, Grade B, Schedule 40, zinc coated, plain ends.
- 2. Cast-Iron Pipe Sleeves: Cast or fabricated "wall pipe," equivalent to ductile-iron pressure pipe, with plain ends and integral waterstop unless otherwise indicated.

- B. Sleeves for Conduits Penetrating Non-Fire-Rated Gypsum Board Assemblies: Galvanized-steel sheet; 0.0239-inch minimum thickness; round tube closed with welded longitudinal joint, with tabs for screw-fastening the sleeve to the board.
- C. PVC-Pipe Sleeves: ASTM D 1785, Schedule 40.
- D. Molded-PVC Sleeves: With nailing flange for attaching to wooden forms.
- E. Molded-PE or -PP Sleeves: Removable, tapered-cup shaped, and smooth outer surface with nailing flange for attaching to wooden forms.
- F. Sleeves for Rectangular Openings:
 - 1. Material: Galvanized sheet steel.
 - 2. Minimum Metal Thickness:
 - a. For sleeve cross-section rectangle perimeter less than 50 inches and with no side larger than 16 inches, thickness shall be 0.052 inch.
 - b. For sleeve cross-section rectangle perimeter 50 inches or more and one or more sides larger than 16 inches, thickness shall be 0.138 inch.

2.2 SLEEVE-SEAL SYSTEMS

- A. Description: Modular sealing device, designed for field assembly, to fill annular space between sleeve and raceway or cable.
 - 1. Manufacturers: Subject to compliance with requirements, provide products by one of the following available manufacturers offering products that may be incorporated into the Work include, but are not limited to, the following:
 - a. Advance Products & Systems, Inc.
 - b. CALPICO, Inc.
 - c. Pipeline Seal and Insulator, Inc.
 - 2. Sealing Elements: EPDM rubber interlocking links shaped to fit surface of pipe. Include type and number required for pipe material and size of pipe.
 - 3. Pressure Plates: Carbon steel.
 - 4. Connecting Bolts and Nuts: Carbon steel, with corrosion-resistant coating, of length required to secure pressure plates to sealing elements.

2.3 SLEEVE-SEAL FITTINGS

- A. Description: Manufactured plastic, sleeve-type, waterstop assembly made for embedding in concrete slab or wall. Unit shall have plastic or rubber waterstop collar with center opening to match piping OD.
 - 1. Manufacturers: Subject to compliance with requirements, provide products by one of the following available manufacturers offering products that may be incorporated into the Work include, but are not limited to, the following:
 - a. Presealed Systems.

2.4 GROUT

- A. Description: Nonshrink; recommended for interior and exterior sealing openings in non-fire-rated walls or floors.
- B. Standard: ASTM C 1107/C 1107M, Grade B, post-hardening and volume-adjusting, dry, hydraulic-cement grout.
- C. Design Mix: 5000-psi, 28-day compressive strength.
- D. Packaging: Premixed and factory packaged.

2.5 SILICONE SEALANTS

- A. Silicone Sealants: Single-component, silicone-based, neutral-curing elastomeric sealants of grade indicated below.
 - 1. Grade: Pourable (self-leveling) formulation for openings in floors and other horizontal surfaces that are not fire rated.
 - 2. Sealant shall have VOC content of 420 g/L or less when calculated according to 40 CFR 59, Subpart D (EPA Method 24).
- B. Silicone Foams: Multicomponent, silicone-based liquid elastomers that, when mixed, expand and cure in place to produce a flexible, nonshrinking foam.

PART 3 - EXECUTION

3.1 SLEEVE INSTALLATION FOR NON-FIRE-RATED ELECTRICAL PENETRATIONS

- A. Comply with NECA 1.
- B. Comply with NEMA VE 2 for cable tray and cable penetrations.
- C. Sleeves for Conduits Penetrating Above-Grade Non-Fire-Rated Concrete and Masonry-Unit Floors and Walls:
 - 1. Interior Penetrations of Non-Fire-Rated Walls and Floors:
 - a. Seal annular space between sleeve and raceway or cable, using joint sealant appropriate for size, depth, and location of joint. Comply with requirements in Section 079200 "Joint Sealants."
 - b. Seal space outside of sleeves with mortar or grout. Pack sealing material solidly between sleeve and wall so no voids remain. Tool exposed surfaces smooth; protect material while curing.

2. Use pipe sleeves unless penetration arrangement requires rectangular sleeved opening.
3. Size pipe sleeves to provide 1/4-inch annular clear space between sleeve and raceway or cable unless sleeve seal is to be installed.
4. Install sleeves for wall penetrations unless core-drilled holes or formed openings are used. Install sleeves during erection of walls. Cut sleeves to length for mounting flush with both surfaces of walls. Deburr after cutting.
5. Install sleeves for floor penetrations. Extend sleeves installed in floors 2 inches above finished floor level. Install sleeves during erection of floors.

D. Sleeves for Conduits Penetrating Non-Fire-Rated Gypsum Board Assemblies:

1. Use circular metal sleeves unless penetration arrangement requires rectangular sleeved opening.
2. Seal space outside of sleeves with approved joint compound for gypsum board assemblies.

3.2 SLEEVE-SEAL-SYSTEM INSTALLATION

- A. Install sleeve-seal systems in sleeves in exterior concrete walls and slabs-on-grade at raceway entries into building.
- B. Install type and number of sealing elements recommended by manufacturer for raceway or cable material and size. Position raceway or cable in center of sleeve. Assemble mechanical sleeve seals and install in annular space between raceway or cable and sleeve. Tighten bolts against pressure plates that cause sealing elements to expand and make watertight seal.

3.3 SLEEVE-SEAL-FITTING INSTALLATION

- A. Install sleeve-seal fittings in new walls and slabs as they are constructed.
- B. Assemble fitting components of length to be flush with both surfaces of concrete slabs and walls. Position waterstop flange to be centered in concrete slab or wall.
- C. Secure nailing flanges to concrete forms.
- D. Using grout, seal the space around outside of sleeve-seal fittings.

END OF SECTION 260544

SECTION 260553

IDENTIFICATION FOR ELECTRICAL SYSTEMS

PART 1 - GENERAL

1.1 RELATED DOCUMENTS

- A. Drawings and general provisions of the Contract, including General and Supplementary Conditions and Division 01 Specification Sections, apply to this Section.

1.2 SUMMARY

- A. Section Includes:
 - 1. Identification for raceways.
 - 2. Identification of power and control cables.
 - 3. Identification for conductors.
 - 4. Warning labels and signs.
 - 5. Instruction signs.
 - 6. Equipment identification labels.
 - 7. Miscellaneous identification products.

1.3 ACTION SUBMITTALS

- A. Product Data: For each electrical identification product indicated.
- B. Identification Schedule: An index of nomenclature of electrical equipment and system components used in identification signs and labels.

1.4 QUALITY ASSURANCE

- A. Comply with ANSI A13.1 and IEEE C2.
- B. Comply with NFPA 70.
- C. Comply with 29 CFR 1910.144 and 29 CFR 1910.145.
- D. Comply with ANSI Z535.4 for safety signs and labels.
- E. Adhesive-attached labeling materials, including label stocks, laminating adhesives, and inks used by label printers, shall comply with UL 969.

1.5 COORDINATION

- A. Coordinate identification names, abbreviations, colors, and other features with requirements in other Sections requiring identification applications, Drawings, Shop Drawings, manufacturer's wiring diagrams, and the Operation and Maintenance Manual; and with those required by codes, standards, and 29 CFR 1910.145. Use consistent designations throughout Project.
- B. Coordinate installation of identifying devices with completion of covering and painting of surfaces where devices are to be applied.
- C. Coordinate installation of identifying devices with location of access panels and doors.
- D. Install identifying devices before installing acoustical ceilings and similar concealment.

PART 2 - PRODUCTS

2.1 POWER AND CONTROL RACEWAY IDENTIFICATION MATERIALS

- A. Comply with ANSI A13.1 for minimum size of letters for legend and for minimum length of color field for each raceway size.
- B. Colors for Raceways Carrying Circuits at 600 V or Less:
 - 1. Black letters on an orange field.
 - 2. Legend: Indicate voltage and system or service type.
- C. Colors for Raceways Carrying Circuits at More Than 600 V:
 - 1. Black letters on an orange field.
 - 2. Legend: "DANGER CONCEALED HIGH VOLTAGE WIRING."
- D. Vinyl Labels for Raceways Carrying Circuits at 600 V or Less: Preprinted, flexible label laminated with a clear, weather- and chemical-resistant coating and matching wraparound clear adhesive tape for securing ends of legend label.
- E. Snap-Around, Color-Coding Bands for Raceways Carrying Circuits at 600 V or Less: Slit, pretensioned, flexible, solid-colored acrylic sleeve, 2 inches long, with diameter sized to suit diameter of raceway or cable it identifies and to stay in place by gripping action.
- F. Tape and Stencil for Raceways Carrying Circuits More Than 600 V: 4-inch-wide black stripes on 10-inch centers diagonally over orange background that extends full length of raceway or duct and is 12 inches wide. Stop stripes at legends.
- G. Metal Tags: Brass or aluminum, 2 by 2 by 0.05 inch, with stamped legend, punched for use with self-locking cable tie fastener.

- H. Write-On Tags: Polyester tag, 0.010 inch thick, with corrosion-resistant grommet and cable tie for attachment to conductor or cable.
 - 1. Marker for Tags: Permanent, waterproof, black ink marker recommended by tag manufacturer.
 - 2. Marker for Tags: Machine-printed, permanent, waterproof, black ink marker recommended by printer manufacturer.

2.2 ARMORED AND METAL-CLAD CABLE IDENTIFICATION MATERIALS

- A. Comply with ANSI A13.1 for minimum size of letters for legend and for minimum length of color field for each cable size.
- B. Colors for Cables Carrying Circuits at 600 V and Less:
 - 1. Black letters on an orange field.
 - 2. Legend: Indicate voltage and system or service type.
- C. Colors for Cables Carrying Circuits at More Than 600 V:
 - 1. Black letters on an orange field.
 - 2. Legend: "DANGER HIGH VOLTAGE WIRING."
- D. Vinyl Labels: Preprinted, flexible label laminated with a clear, weather- and chemical-resistant coating and matching wraparound clear adhesive tape for securing ends of legend label.
- E. Self-Adhesive Vinyl Tape: Colored, heavy duty, waterproof, fade resistant; 2 inches wide; compounded for outdoor use.
- F. Heat-Shrink Preprinted Tubes: Flame-retardant polyolefin tube with machine-printed identification label. Sized to suit diameter of and shrinks to fit firmly around cable it identifies. Full shrink recovery at a maximum of 200 deg F. Comply with UL 224.

2.3 POWER AND CONTROL CABLE IDENTIFICATION MATERIALS

- A. Comply with ANSI A13.1 for minimum size of letters for legend and for minimum length of color field for each cable size.
- B. Vinyl Labels: Preprinted, flexible label laminated with a clear, weather- and chemical-resistant coating and matching wraparound clear adhesive tape for securing ends of legend label.
- C. Self-Adhesive, Self-Laminating Polyester Labels: Write-on, 3-mil-thick flexible label with acrylic pressure-sensitive adhesive that provides a clear, weather- and chemical-resistant, self-laminating, protective shield over the legend. Labels sized to fit the cable diameter such that the clear shield overlaps the entire printed legend.

- D. Heat-Shrink Preprinted Tubes: Flame-retardant polyolefin tube with machine-printed identification label. Sized to suit diameter of and shrinks to fit firmly around cable it identifies. Full shrink recovery at a maximum of 200 deg F. Comply with UL 224.
- E. Metal Tags: Brass or aluminum, 2 by 2 by 0.05 inch, with stamped legend, punched for use with self-locking cable tie fastener.
- F. Write-On Tags: Polyester tag, 0.010 inch thick, with corrosion-resistant grommet and cable tie for attachment to conductor or cable.
 - 1. Marker for Tags: Permanent, waterproof, black ink marker recommended by tag manufacturer.
 - 2. Marker for Tags: Machine-printed, permanent, waterproof, black ink marker recommended by printer manufacturer.
- G. Snap-Around, Color-Coding Bands: Slit, pretensioned, flexible, solid-colored acrylic sleeve, 2 inches long, with diameter sized to suit diameter of cable it identifies and to stay in place by gripping action.

2.4 CONDUCTOR IDENTIFICATION MATERIALS

- A. Color-Coding Conductor Tape: Colored, self-adhesive vinyl tape not less than 3 mils thick by 1 to 2 inches wide.
- B. Self-Adhesive, Self-Laminating Polyester Labels: Write-on, 3-mil-thick flexible label with acrylic pressure-sensitive adhesive that provides a clear, weather- and chemical-resistant, self-laminating, protective shield over the legend. Labels sized to fit the conductor diameter such that the clear shield overlaps the entire printed legend.
- C. Heat-Shrink Preprinted Tubes: Flame-retardant polyolefin tube with machine-printed identification label. Sized to suit diameter of and shrinks to fit firmly around conductor it identifies. Full shrink recovery at a maximum of 200 deg F. Comply with UL 224.
- D. Marker Tapes: Vinyl or vinyl-cloth, self-adhesive wraparound type, with circuit identification legend machine printed by thermal transfer or equivalent process.
- E. Write-On Tags: Polyester tag, 0.010 inch thick, with corrosion-resistant grommet and cable tie for attachment to conductor or cable.
 - 1. Marker for Tags: Permanent, waterproof, black ink marker recommended by tag manufacturer.
 - 2. Labels for Tags: Self-adhesive label, machine-printed with permanent, waterproof, black ink recommended by printer manufacturer, sized for attachment to tag.

2.5 WARNING LABELS AND SIGNS

- A. Comply with NFPA 70 and 29 CFR 1910.145.

- B. Self-Adhesive Warning Labels: Factory-printed, multicolor, pressure-sensitive adhesive labels, configured for display on front cover, door, or other access to equipment unless otherwise indicated.
- C. Baked-Enamel Warning Signs:
 - 1. Preprinted aluminum signs, punched or drilled for fasteners, with colors, legend, and size required for application.
 - 2. 1/4-inch grommets in corners for mounting.
 - 3. Nominal size, 7 by 10 inches.
- D. Metal-Backed, Butyrate Warning Signs:
 - 1. Weather-resistant, nonfading, preprinted, cellulose-acetate butyrate signs with 0.0396-inch galvanized-steel backing; and with colors, legend, and size required for application.
 - 2. 1/4-inch grommets in corners for mounting.
 - 3. Nominal size, 10 by 14 inches.
- E. Warning label and sign shall include, but are not limited to, the following legends:
 - 1. Multiple Power Source Warning: "DANGER - ELECTRICAL SHOCK HAZARD - EQUIPMENT HAS MULTIPLE POWER SOURCES."
 - 2. Workspace Clearance Warning: "WARNING - OSHA REGULATION - AREA IN FRONT OF ELECTRICAL EQUIPMENT MUST BE KEPT CLEAR FOR 36 INCHES."

2.6 INSTRUCTION SIGNS

- A. Engraved, laminated acrylic or melamine plastic, minimum 1/16 inch thick for signs up to 20 sq. inches and 1/8 inch thick for larger sizes.
 - 1. Engraved legend with black letters on white face.
 - 2. Punched or drilled for mechanical fasteners.
 - 3. Framed with mitered acrylic molding and arranged for attachment at applicable equipment.
- B. Adhesive Film Label with Clear Protective Overlay: Machine printed, in black, by thermal transfer or equivalent process. Minimum letter height shall be 3/8 inch. Overlay shall provide a weatherproof and UV-resistant seal for label.

2.7 EQUIPMENT IDENTIFICATION LABELS

- A. Adhesive Film Label with Clear Protective Overlay: Machine printed, in black, by thermal transfer or equivalent process. Minimum letter height shall be 3/8 inch. Overlay shall provide a weatherproof and UV-resistant seal for label.

- B. Self-Adhesive, Engraved, Laminated Acrylic or Melamine Label: Adhesive backed, with white letters on a dark-gray background. Minimum letter height shall be 3/8 inch.
- C. Engraved, Laminated Acrylic or Melamine Label: Punched or drilled for screw mounting. White letters on a dark-gray background. Minimum letter height shall be 3/8 inch.
- D. Stenciled Legend: In nonfading, waterproof, black ink or paint. Minimum letter height shall be 1 inch.

2.8 CABLE TIES

- A. General-Purpose Cable Ties: Fungus inert, self extinguishing, one piece, self locking, Type 6/6 nylon.
 - 1. Minimum Width: 3/16 inch.
 - 2. Tensile Strength at 73 deg F, According to ASTM D 638: 12,000 psi.
 - 3. Temperature Range: Minus 40 to plus 185 deg F.
 - 4. Color: Black except where used for color-coding.
- B. UV-Stabilized Cable Ties: Fungus inert, designed for continuous exposure to exterior sunlight, self extinguishing, one piece, self locking, Type 6/6 nylon.
 - 1. Minimum Width: 3/16 inch.
 - 2. Tensile Strength at 73 deg F, According to ASTM D 638: 12,000 psi.
 - 3. Temperature Range: Minus 40 to plus 185 deg F.
 - 4. Color: Black.
- C. Plenum-Rated Cable Ties: Self extinguishing, UV stabilized, one piece, self locking.
 - 1. Minimum Width: 3/16 inch.
 - 2. Tensile Strength at 73 deg F, According to ASTM D 638: 7000 psi.
 - 3. UL 94 Flame Rating: 94V-0.
 - 4. Temperature Range: Minus 50 to plus 284 deg F.
 - 5. Color: Black.

2.9 MISCELLANEOUS IDENTIFICATION PRODUCTS

- A. Paint: Comply with requirements in painting Sections for paint materials and application requirements. Select paint system applicable for surface material and location (exterior or interior).
- B. Fasteners for Labels and Signs: Self-tapping, stainless-steel screws or stainless-steel machine screws with nuts and flat and lock washers.

PART 3 - EXECUTION

3.1 INSTALLATION

- A. Verify identity of each item before installing identification products.
- B. Location: Install identification materials and devices at locations for most convenient viewing without interference with operation and maintenance of equipment.
- C. Apply identification devices to surfaces that require finish after completing finish work.
- D. Self-Adhesive Identification Products: Clean surfaces before application, using materials and methods recommended by manufacturer of identification device.
- E. Attach signs and plastic labels that are not self-adhesive type with mechanical fasteners appropriate to the location and substrate.
- F. Attach plastic raceway and cable labels that are not self-adhesive type with clear vinyl tape with adhesive appropriate to the location and substrate.
- G. System Identification Color-Coding Bands for Raceways and Cables: Each color-coding band shall completely encircle cable or conduit. Place adjacent bands of two-color markings in contact, side by side. Locate bands at changes in direction, at penetrations of walls and floors, at 50-foot maximum intervals in straight runs, and at 25-foot maximum intervals in congested areas.
- H. Aluminum Wraparound Marker Labels and Metal Tags: Secure tight to surface of conductor or cable at a location with high visibility and accessibility.
- I. Cable Ties: For attaching tags. Use general-purpose type, except as listed below:
 - 1. Outdoors: UV-stabilized nylon.
 - 2. In Spaces Handling Environmental Air: Plenum rated.
- J. Painted Identification: Comply with requirements in painting Sections for surface preparation and paint application.

3.2 IDENTIFICATION SCHEDULE

- A. Accessible Raceways 600 V or Less, for Branch Circuits More Than 30 A, and 120 V to ground: Identify with self-adhesive vinyl label. Install labels at 10-foot maximum intervals.
- B. Accessible Raceways and Cables within Buildings: Identify the covers of each junction and pull box of the following systems with self-adhesive vinyl labels with the wiring system legend and system voltage. System legends shall be as follows:
 - 1. Emergency Power.

2. Power.
 - C. Power-Circuit Conductor Identification, 600 V or Less: For conductors in vaults, pull and junction boxes, manholes, and handholes, use color-coding conductor tape to identify the phase.
 1. Color-Coding for Phase and Voltage Level Identification, 600 V or Less: Use colors listed below for ungrounded feeder and branch-circuit conductors.
 - a. Color shall be factory applied or field applied for sizes larger than No. 8 AWG, if authorities having jurisdiction permit.
 - b. Colors for 208/120-V Circuits:
 - 1) Phase A: Black.
 - 2) Phase B: Red.
 - 3) Phase C: Blue.
 - c. Colors for 480/277-V Circuits:
 - 1) Phase A: Brown.
 - 2) Phase B: Orange.
 - 3) Phase C: Yellow.
 - d. Field-Applied, Color-Coding Conductor Tape: Apply in half-lapped turns for a minimum distance of 6 inches from terminal points and in boxes where splices or taps are made. Apply last two turns of tape with no tension to prevent possible unwinding. Locate bands to avoid obscuring factory cable markings.
 - D. Power-Circuit Conductor Identification, More than 600 V: For conductors in vaults, pull and junction boxes, manholes, and handholes, use write-on tags.
 - E. Install instructional sign including the color-code for grounded and ungrounded conductors using adhesive-film-type labels.
 - F. Control-Circuit Conductor Identification: For conductors and cables in pull and junction boxes, manholes, and handholes, use write-on tags with the conductor or cable designation, origin, and destination.
 - G. Control-Circuit Conductor Termination Identification: For identification at terminations provide heat-shrink preprinted tubes with the conductor designation.
 - H. Conductors to Be Extended in the Future: Attach write-on tags to conductors and list source.
 - I. Auxiliary Electrical Systems Conductor Identification: Identify field-installed alarm, control, and signal connections.
 1. Identify conductors, cables, and terminals in enclosures and at junctions, terminals, and pull points. Identify by system and circuit designation.

2. Use system of marker tape designations that is uniform and consistent with system used by manufacturer for factory-installed connections.
 3. Coordinate identification with Project Drawings, manufacturer's wiring diagrams, and the Operation and Maintenance Manual.
- J. Warning Labels for Indoor Cabinets, Boxes, and Enclosures for Power and Lighting: Self-adhesive warning labels.
1. Comply with 29 CFR 1910.145.
 2. Identify system voltage with black letters on an orange background.
 3. Apply to exterior of door, cover, or other access.
 4. For equipment with multiple power or control sources, apply to door or cover of equipment including, but not limited to, the following:
 - a. Power transfer switches.
 - b. Controls with external control power connections.
- K. Operating Instruction Signs: Install instruction signs to facilitate proper operation and maintenance of electrical systems and items to which they connect. Install instruction signs with approved legend where instructions are needed for system or equipment operation.
- L. Equipment Identification Labels: On each unit of equipment, install unique designation label that is consistent with wiring diagrams, schedules, and the Operation and Maintenance Manual. Apply labels to disconnect switches and protection equipment, central or master units, control panels, control stations, terminal cabinets, and racks of each system. Systems include power, lighting, control, communication, signal, monitoring, and alarm systems unless equipment is provided with its own identification.
1. Labeling Instructions:
 - a. Indoor Equipment: Adhesive film label with clear protective overlay. Unless otherwise indicated, provide a single line of text with 1/2-inch-high letters on 1-1/2-inch-high label; where two lines of text are required, use labels 2 inches high.
 - b. Elevated Components: Increase sizes of labels and letters to those appropriate for viewing from the floor.
 - c. Unless provided with self-adhesive means of attachment, fasten labels with appropriate mechanical fasteners that do not change the NEMA or NRTL rating of the enclosure.
 2. Equipment to Be Labeled:
 - a. Panelboards: Typewritten directory of circuits in the location provided by panelboard manufacturer. Panelboard identification shall be self-adhesive, engraved, laminated acrylic or melamine label.
 - b. Enclosures and electrical cabinets.
 - c. Access doors and panels for concealed electrical items.
 - d. Enclosed switches.
 - e. Enclosed circuit breakers.

- f. Enclosed controllers.

END OF SECTION 260553

SECTION 262813

FUSES

PART 1 - GENERAL

1.1 RELATED DOCUMENTS

- A. Drawings and general provisions of the Contract, including General and Supplementary Conditions and Division 01 Specification Sections, apply to this Section.

1.2 SUMMARY

- A. Section Includes:
 - 1. Cartridge fuses rated 600 V ac and less for use in the following:
 - a. Control circuits.
 - b. Enclosed controllers.
 - c. Enclosed switches.
 - 2. Spare-fuse cabinets.

1.3 ACTION SUBMITTALS

- A. Product Data: For each type of product. Include construction details, material descriptions, dimensions of individual components and profiles, and finishes for spare-fuse cabinets. Include the following for each fuse type indicated:
 - 1. Ambient Temperature Adjustment Information: If ratings of fuses have been adjusted to accommodate ambient temperatures, provide list of fuses with adjusted ratings.
 - a. For each fuse having adjusted ratings, include location of fuse, original fuse rating, local ambient temperature, and adjusted fuse rating.
 - b. Provide manufacturer's technical data on which ambient temperature adjustment calculations are based.
 - 2. Dimensions and manufacturer's technical data on features, performance, electrical characteristics, and ratings.

1.4 MAINTENANCE MATERIAL SUBMITTALS

- A. Furnish extra materials that match products installed and that are packaged with protective covering for storage and identified with labels describing contents.
 - 1. Fuses: Equal to 10 percent of quantity installed for each size and type, but no fewer than 10 of each size and type.

1.5 FIELD CONDITIONS

- A. Where ambient temperature to which fuses are directly exposed is less than 40 deg F or more than 100 deg F, apply manufacturer's ambient temperature adjustment factors to fuse ratings.

PART 2 - PRODUCTS

2.1 MANUFACTURERS

- A. Manufacturers: Subject to compliance with requirements, provide products by one of the following available manufacturers offering products that may be incorporated into the Work include, but are not limited to, the following:
 - 1. Cooper Bussmann, Inc.
 - 2. Edison Fuse, Inc.
 - 3. Littlefuse, Inc.
- B. Source Limitations: Obtain fuses, for use within a specific product or circuit, from single source from single manufacturer.

2.2 CARTRIDGE FUSES

- A. Electrical Components, Devices, and Accessories: Listed and labeled as defined in NFPA 70, by a qualified testing agency, and marked for intended location and application.
- B. Comply with NEMA FU 1 for cartridge fuses.
- C. Comply with NFPA 70.
- D. Coordinate fuse ratings with utilization equipment nameplate limitations of maximum fuse size and with system short-circuit current levels.

2.3 SPARE-FUSE CABINET

- A. Characteristics: Wall-mounted steel unit with full-length, recessed piano-hinged door and key-coded cam lock and pull.

1. Size: Adequate for storage of spare fuses specified with 15 percent spare capacity minimum.
2. Finish: Gray, baked enamel.
3. Identification: "SPARE FUSES" in 1-1/2-inch-high letters on exterior of door.
4. Fuse Pullers: For each size of fuse, where applicable and available, from fuse manufacturer.

PART 3 - EXECUTION

3.1 EXAMINATION

- A. Examine fuses before installation. Reject fuses that are moisture damaged or physically damaged.
- B. Examine holders to receive fuses for compliance with installation tolerances and other conditions affecting performance, such as rejection features.
- C. Examine utilization equipment nameplates and installation instructions. Install fuses of sizes and with characteristics appropriate for each piece of equipment.
- D. Evaluate ambient temperatures to determine if fuse rating adjustment factors must be applied to fuse ratings.
- E. Proceed with installation only after unsatisfactory conditions have been corrected.

3.2 FUSE APPLICATIONS

- A. Cartridge Fuses:
 1. Feeders: Class L, fast acting.
 2. Motor Branch Circuits: Class RK1, time delay.
 3. Power Electronics Circuits: Class J, high speed.
 4. Other Branch Circuits: Class RK1, time delay.
 5. Control Transformer Circuits: Class CC, time delay, control transformer duty.
 6. Provide open-fuse indicator fuses or fuse covers with open fuse indication.

3.3 INSTALLATION

- A. Install fuses in fusible devices. Arrange fuses so rating information is readable without removing fuse.
- B. Install spare-fuse cabinet(s) in location shown on the Drawings or as indicated in the field by Construction Manager.

3.4 IDENTIFICATION

- A. Install labels complying with requirements for identification specified in Section 260553 "Identification for Electrical Systems" and indicating fuse replacement information inside of door of each fused switch and adjacent to each fuse block, socket, and holder.

END OF SECTION 262813

SECTION 262816

ENCLOSED SWITCHES AND CIRCUIT BREAKERS

PART 1 - GENERAL

1.1 RELATED DOCUMENTS

- A. Drawings and general provisions of the Contract, including General and Supplementary Conditions and other Division 01 Specification Sections, apply to this Section.

1.2 SUMMARY

- A. Section Includes:
 - 1. Fusible switches.
 - 2. Enclosures.

1.3 DEFINITIONS

- A. NC: Normally closed.
- B. NO: Normally open.
- C. SPDT: Single pole, double throw.

1.4 ACTION SUBMITTALS

- A. Product Data: For each type of enclosed switch, circuit breaker, accessory, and component indicated. Include dimensioned elevations, sections, weights, and manufacturers' technical data on features, performance, electrical characteristics, ratings, accessories, and finishes.
 - 1. Enclosure types and details for types other than NEMA 250, Type 1.
 - 2. Current and voltage ratings.
 - 3. Short-circuit current ratings (interrupting and withstand, as appropriate).
 - 4. Detail features, characteristics, ratings, and factory settings of individual overcurrent protective devices, accessories, and auxiliary components.
- B. Shop Drawings: For enclosed switches and circuit breakers. Include plans, elevations, sections, details, and attachments to other work.
 - 1. Wiring Diagrams: For power, signal, and control wiring.

1.5 INFORMATIONAL SUBMITTALS

- A. Qualification Data: For qualified testing agency.
- B. Field quality-control reports.
 - 1. Test procedures used.
 - 2. Test results that comply with requirements.
 - 3. Results of failed tests and corrective action taken to achieve test results that comply with requirements.
- C. Manufacturer's field service report.

1.6 CLOSEOUT SUBMITTALS

- A. Operation and Maintenance Data: For enclosed switches and circuit breakers to include in emergency, operation, and maintenance manuals. In addition to items specified in Section 017823 "Operation and Maintenance Data," include the following:
 - 1. Manufacturer's written instructions for testing and adjusting enclosed switches and circuit breakers.

1.7 MAINTENANCE MATERIAL SUBMITTALS

- A. Furnish extra materials that match products installed and that are packaged with protective covering for storage and identified with labels describing contents.
 - 1. Fuses: Equal to 10 percent of quantity installed for each size and type, but no fewer than three of each size and type.
 - 2. Fuse Pullers: Two for each size and type.

1.8 QUALITY ASSURANCE

- A. Testing Agency Qualifications: Member company of NETA or an NRTL.
 - 1. Testing Agency's Field Supervisor: Currently certified by NETA to supervise on-site testing.
- B. Source Limitations: Obtain enclosed switches and circuit breakers, overcurrent protective devices, components, and accessories, within same product category, from single source from single manufacturer.
- C. Product Selection for Restricted Space: Drawings indicate maximum dimensions for enclosed switches and circuit breakers, including clearances between enclosures, and adjacent surfaces and other items. Comply with indicated maximum dimensions.

- D. Electrical Components, Devices, and Accessories: Listed and labeled as defined in NFPA 70, by a qualified testing agency, and marked for intended location and application.
- E. Comply with NFPA 70.

1.9 PROJECT CONDITIONS

- A. Environmental Limitations: Rate equipment for continuous operation under the following conditions unless otherwise indicated:
 - 1. Ambient Temperature: Not less than minus 22 deg F and not exceeding 104 deg F.
 - 2. Altitude: Not exceeding 6600 feet.
- B. Interruption of Existing Electric Service: Do not interrupt electric service to facilities occupied by Owner or others unless permitted under the following conditions and then only after arranging to provide temporary electric service according to requirements indicated:
 - 1. Notify Construction Manager no fewer than seven days in advance of proposed interruption of electric service.
 - 2. Indicate method of providing temporary electric service.
 - 3. Do not proceed with interruption of electric service without Construction Manager's written permission.
 - 4. Comply with NFPA 70E.

1.10 COORDINATION

- A. Coordinate layout and installation of switches, circuit breakers, and components with equipment served and adjacent surfaces. Maintain required workspace clearances and required clearances for equipment access doors and panels.

PART 2 - PRODUCTS

2.1 FUSIBLE SWITCHES

- A. Manufacturers: Subject to compliance with requirements, provide products by one of the following available manufacturers offering products that may be incorporated into the Work include, but are not limited to, the following:
 - 1. Eaton Electrical Inc.; Cutler-Hammer Business Unit.
 - 2. General Electric Company;
 - 3. Square D; a brand of Schneider Electric
- B. Type HD, Heavy Duty, Single Throw, 600-V ac, 1200 A and Smaller: UL 98 and NEMA KS 1, horsepower rated, with clips or bolt pads to accommodate indicated

fuses, lockable handle with capability to accept three padlocks, and interlocked with cover in closed position.

C. Accessories:

1. Equipment Ground Kit: Internally mounted and labeled for copper and aluminum ground conductors.
2. Neutral Kit: Internally mounted; insulated, capable of being grounded and bonded; labeled for copper and aluminum neutral conductors.
3. Class R Fuse Kit: Provides rejection of other fuse types when Class R fuses are specified.
4. Auxiliary Contact Kit: One NO/NC (Form "C") auxiliary contact(s), arranged to activate before switch blades open.
5. Lugs: Mechanical type, suitable for number, size, and conductor material.
6. Service-Rated Switches: Labeled for use as service equipment.

2.2 ENCLOSURES

- A. Enclosed Switches and Circuit Breakers: NEMA AB 1, NEMA KS 1, NEMA 250, and UL 50, to comply with environmental conditions at installed location.
1. Indoor, Dry and Clean Locations: NEMA 250, Type 1.
 2. Other Wet or Damp, Indoor Locations: NEMA 250, Type 4.
 3. Indoor Locations Subject to Dust, Falling Dirt, and Dripping Noncorrosive Liquids: NEMA 250, Type 12.

PART 3 - EXECUTION

3.1 EXAMINATION

- A. Examine elements and surfaces to receive enclosed switches and circuit breakers for compliance with installation tolerances and other conditions affecting performance of the Work.
- B. Proceed with installation only after unsatisfactory conditions have been corrected.

3.2 INSTALLATION

- A. Install individual wall-mounted switches and circuit breakers with tops at uniform height unless otherwise indicated.
- B. Temporary Lifting Provisions: Remove temporary lifting eyes, channels, and brackets and temporary blocking of moving parts from enclosures and components.
- C. Install fuses in fusible devices.

- D. Comply with NECA 1.

3.3 IDENTIFICATION

- A. Comply with requirements in Section 260553 "Identification for Electrical Systems."
 - 1. Identify field-installed conductors, interconnecting wiring, and components; provide warning signs.
 - 2. Label each enclosure with engraved metal or laminated-plastic nameplate.

3.4 FIELD QUALITY CONTROL

- A. Testing Agency: Engage a qualified testing agency to perform tests and inspections.
- B. Manufacturer's Field Service: Engage a factory-authorized service representative to inspect, test, and adjust components, assemblies, and equipment installations, including connections.
- C. Acceptance Testing Preparation:
 - 1. Test insulation resistance for each enclosed switch and circuit breaker, component, connecting supply, feeder, and control circuit.
 - 2. Test continuity of each circuit.
- D. Tests and Inspections:
 - 1. Perform each visual and mechanical inspection and electrical test stated in NETA Acceptance Testing Specification. Certify compliance with test parameters.
 - 2. Correct malfunctioning units on-site, where possible, and retest to demonstrate compliance; otherwise, replace with new units and retest.
 - 3. Perform the following infrared scan tests and inspections and prepare reports:
 - a. Initial Infrared Scanning: After Substantial Completion, but not more than 60 days after Final Acceptance, perform an infrared scan of each enclosed switch and circuit breaker. Remove front panels so joints and connections are accessible to portable scanner.
 - b. Follow-up Infrared Scanning: Perform an additional follow-up infrared scan of each enclosed switch and circuit breaker 11 months after date of Substantial Completion.
 - c. Instruments and Equipment: Use an infrared scanning device designed to measure temperature or to detect significant deviations from normal values. Provide calibration record for device.
 - 4. Test and adjust controls, remote monitoring, and safeties. Replace damaged and malfunctioning controls and equipment.
- E. Enclosed switches and circuit breakers will be considered defective if they do not pass tests and inspections.

- F. Prepare test and inspection reports, including a certified report that identifies enclosed switches and circuit breakers and that describes scanning results. Include notation of deficiencies detected, remedial action taken, and observations after remedial action.

3.5 ADJUSTING

- A. Adjust moving parts and operable components to function smoothly, and lubricate as recommended by manufacturer.

END OF SECTION 262816

SECTION 262913

ENCLOSED CONTROLLERS

PART 1 - GENERAL

1.1 RELATED DOCUMENTS

- A. Drawings and general provisions of the Contract, including General and Supplementary Conditions and Division 01 Specification Sections, apply to this Section.

1.2 SUMMARY

- A. Section includes the following enclosed controllers rated 600 V and less:
 - 1. Full-voltage magnetic.

1.3 DEFINITIONS

- A. CPT: Control power transformer.
- B. MCCB: Molded-case circuit breaker.
- C. MCP: Motor circuit protector.
- D. N.C.: Normally closed.
- E. N.O.: Normally open.
- F. OCPD: Overcurrent protective device.

1.4 ACTION SUBMITTALS

- A. Product Data: For each type of enclosed controller. Include manufacturer's technical data on features, performance, electrical characteristics, ratings, and enclosure types and finishes.
- B. Shop Drawings: For each enclosed controller. Include dimensioned plans, elevations, sections, details, and required clearances and service spaces around controller enclosures.
 - 1. Show tabulations of the following:
 - a. Each installed unit's type and details.

- b. Factory-installed devices.
 - c. Nameplate legends.
 - d. Short-circuit current rating of integrated unit.
 - e. Features, characteristics, ratings, and factory settings of individual OCPDs in combination controllers.
2. Wiring Diagrams: For power, signal, and control wiring.

1.5 INFORMATIONAL SUBMITTALS

- A. Qualification Data: For qualified testing agency.
- B. Field quality-control reports.
- C. Load-Current and List of Settings of Adjustable Overload Relays: Compile after motors have been installed, and arrange to demonstrate that switch settings for motor running overload protection suit actual motors to be protected.

1.6 CLOSEOUT SUBMITTALS

- A. Operation and Maintenance Data: For enclosed controllers to include in emergency, operation, and maintenance manuals. In addition to items specified in Section 017823 "Operation and Maintenance Data," include the following:
 1. Routine maintenance requirements for enclosed controllers and installed components.
 2. Manufacturer's written instructions for setting field-adjustable overload relays.

1.7 MATERIALS MAINTENANCE SUBMITTALS

- A. Furnish extra materials that match products installed and that are packaged with protective covering for storage and identified with labels describing contents.
 1. Fuses for Fused Switches: Equal to 10 percent of quantity installed for each size and type, but no fewer than three of each size and type.
 2. Control Power Fuses: Equal to 10 percent of quantity installed for each size and type, but no fewer than two of each size and type.
 3. Indicating Lights: Two of each type and color installed.
 4. Auxiliary Contacts: Furnish one spare(s) for each size and type of magnetic controller installed.
 5. Power Contacts: Furnish three spares for each size and type of magnetic contactor installed.

1.8 QUALITY ASSURANCE

- A. Testing Agency Qualifications: Member company of NETA or an NRTL.

1. Testing Agency's Field Supervisor: Currently certified by NETA to supervise on-site testing.
- B. Electrical Components, Devices, and Accessories: Listed and labeled as defined in NFPA 70, by a qualified testing agency, and marked for intended location and application.
- C. Comply with NFPA 70.

1.9 PROJECT CONDITIONS

- A. Environmental Limitations: Rate equipment for continuous operation under the following conditions unless otherwise indicated:
 1. Ambient Temperature: Not less than minus 22 deg F and not exceeding 104 deg F.
 2. Altitude: Not exceeding 6600 feet.
- B. Interruption of Existing Electrical Systems: Do not interrupt electrical systems in facilities occupied by Owner or others unless permitted under the following conditions and then only after arranging to provide temporary electrical service according to requirements indicated:
 1. Notify Construction Manager no fewer than two days in advance of proposed interruption of electrical systems.
 2. Indicate method of providing temporary utilities.
 3. Do not proceed with interruption of electrical systems without Construction Manager's written permission.
 4. Comply with NFPA 70E.

1.10 COORDINATION

- A. Coordinate layout and installation of enclosed controllers with other construction including conduit, piping, equipment, and adjacent surfaces. Maintain required workspace clearances and required clearances for equipment access doors and panels.
- B. Coordinate sizes and locations of concrete bases with actual equipment provided. Cast anchor-bolt inserts into bases. Concrete, reinforcement, and formwork requirements are specified with concrete.
- C. Coordinate installation of roof curbs, equipment supports, and roof penetrations.

PART 2 - PRODUCTS

2.1 FULL-VOLTAGE CONTROLLERS

- A. General Requirements for Full-Voltage Controllers: Comply with NEMA ICS 2, general purpose, Class A.
- B. Motor-Starting Switches: "Quick-make, quick-break" toggle or push-button action; marked to show whether unit is off or on.
 - 1. Manufacturers: Subject to compliance with requirements, provide products by one of the following available manufacturers offering products that may be incorporated into the Work include, but are not limited to, the following:
 - a. Eaton Electrical Inc.; Cutler-Hammer Business Unit.
 - b. General Electric Company;
 - c. Square D; a brand of Schneider Electric.
 - 2. Configuration: Nonreversing.
 - 3. Surface mounting.
 - 4. Red pilot light.
- C. Fractional Horsepower Manual Controllers: "Quick-make, quick-break" toggle or push-button action; marked to show whether unit is off, on, or tripped.
 - 1. Manufacturers: Subject to compliance with requirements, provide products by one of the following available manufacturers offering products that may be incorporated into the Work include, but are not limited to, the following:
 - a. Eaton Electrical Inc.; Cutler-Hammer Business Unit.
 - b. General Electric Company;
 - c. Square D; a brand of Schneider Electric.
 - 2.
 - 3. Configuration: Nonreversing.
 - 4. Overload Relays: Inverse-time-current characteristics; NEMA ICS 2, Class 10 tripping characteristics; heaters matched to nameplate full-load current of actual protected motor; external reset push button; bimetallic type.
 - 5. Surface mounting.
 - 6. Red pilot light.
- D. Integral Horsepower Manual Controllers: "Quick-make, quick-break" toggle or push-button action; marked to show whether unit is off, on, or tripped.
 - 1. Manufacturers: Subject to compliance with requirements, provide products by one of the following available manufacturers offering products that may be incorporated into the Work include, but are not limited to, the following:
 - a. Eaton Electrical Inc.; Cutler-Hammer Business Unit.
 - b. General Electric Company;
 - c. Square D; a brand of Schneider Electric.
 - 2. Configuration: Nonreversing.

3. Overload Relays: Inverse-time-current characteristics; NEMA ICS 2, Class 10 tripping characteristics; heaters and sensors in each phase, matched to nameplate full-load current of actual protected motor and having appropriate adjustment for duty cycle; external reset push button; bimetallic type.
 4. Surface mounting.
 5. Red pilot light.
 6. N.O. auxiliary contact.
- E. Magnetic Controllers: Full voltage, across the line, electrically held.
1. Manufacturers: Subject to compliance with requirements, provide products by one of the following available manufacturers offering products that may be incorporated into the Work include, but are not limited to, the following:
 - a. Eaton Electrical Inc.; Cutler-Hammer Business Unit.
 - b. General Electric Company;
 - c. Square D; a brand of Schneider Electric.
 2. Configuration: Nonreversing.
 3. Contactor Coils: Pressure-encapsulated type with coil transient suppressors.
 - a. Operating Voltage: Depending on contactor NEMA size and line-voltage rating, manufacturer's standard matching control power or line voltage.
 4. Power Contacts: Totally enclosed, double-break, silver-cadmium oxide; assembled to allow inspection and replacement without disturbing line or load wiring.
 5. Control Circuits: 24-V ac; obtained from integral CPT, with primary and secondary fuses, with CPT of sufficient capacity to operate integral devices and remotely located pilot, indicating, and control devices.
 - a. CPT Spare Capacity: 50 VA.
 6. Solid-State Overload Relay:
 - a. Switch or dial selectable for motor running overload protection.
 - b. Sensors in each phase.
 - c. Class 10 tripping characteristic selected to protect motor against voltage and current unbalance and single phasing.
 - d. Class II ground-fault protection, with start and run delays to prevent nuisance trip on starting.
 - e. Analog communication module.
 7. N.C., isolated overload alarm contact.
 8. External overload reset push button.
- F. Combination Magnetic Controller: Factory-assembled combination of magnetic controller, OCPD, and disconnecting means.
1. Fusible Disconnecting Means:

- a. NEMA KS 1, heavy-duty, horsepower-rated, fusible switch with clips or bolt pads to accommodate Class R fuses.
 - b. Lockable Handle: Accepts three padlocks and interlocks with cover in closed position.
2. Auxiliary Contacts: N.O./N.C., arranged to activate before switch blades open.

2.2 ENCLOSURES

- A. Enclosed Controllers: NEMA ICS 6, to comply with environmental conditions at installed location.
1. Dry and Clean Indoor Locations: Type 1.
 2. Other Wet or Damp Indoor Locations: Type 4.
 3. Indoor Locations Subject to Dust, Falling Dirt, and Dripping Noncorrosive Liquids: Type 12.

2.3 ACCESSORIES

- A. General Requirements for Control Circuit and Pilot Devices: NEMA ICS 5; factory installed in controller enclosure cover unless otherwise indicated.
1. Push Buttons, Pilot Lights, and Selector Switches: Heavy-duty, oiltight type.
 - a. Push Buttons: Recessed Unguarded types; momentary as indicated.
 - b. Pilot Lights: LED types; colors as indicated; push to test.
 - c. Selector Switches: Rotary type.
- B. Reversible N.C./N.O. auxiliary contact(s).
- C. Control Relays: Auxiliary and adjustable solid-state time-delay relays.
- D. Phase-Failure, Phase-Reversal, and Undervoltage and Overvoltage Relays: Solid-state sensing circuit with isolated output contacts for hard-wired connections. Provide adjustable undervoltage, overvoltage, and time-delay settings.
- E. Cover gaskets for Type 1 enclosures.
- F. Spare control wiring terminal blocks, quantity as indicated; unwired.

PART 3 - EXECUTION

3.1 EXAMINATION

- A. Examine areas and surfaces to receive enclosed controllers, with Installer present, for compliance with requirements and other conditions affecting performance of the Work.

- B. Examine enclosed controllers before installation. Reject enclosed controllers that are wet, moisture damaged, or mold damaged.
- C. Proceed with installation only after unsatisfactory conditions have been corrected.

3.2 INSTALLATION

- A. Wall-Mounted Controllers: Install enclosed controllers on walls with tops at uniform height unless otherwise indicated, and by bolting units to wall or mounting on lightweight structural-steel channels bolted to wall. For controllers not at walls, provide freestanding racks complying with Section 260529 "Hangers and Supports for Electrical Systems."
- B. Temporary Lifting Provisions: Remove temporary lifting eyes, channels, and brackets and temporary blocking of moving parts from enclosures and components.
- C. Install fuses in each fusible-switch enclosed controller.
- D. Install fuses in control circuits if not factory installed. Comply with requirements in Section 262813 "Fuses."
- E. Install heaters in thermal overload relays. Select heaters based on actual nameplate full-load amperes after motors have been installed.
- F. Install, connect, and fuse thermal-protector monitoring relays furnished with motor-driven equipment.
- G. Comply with NECA 1.

3.3 IDENTIFICATION

- A. Identify enclosed controllers, components, and control wiring. Comply with requirements for identification specified in Section 260553 "Identification for Electrical Systems."
 - 1. Identify field-installed conductors, interconnecting wiring, and components; provide warning signs.
 - 2. Label each enclosure with engraved nameplate.
 - 3. Label each enclosure-mounted control and pilot device.

3.4 CONTROL WIRING INSTALLATION

- A. Install wiring between enclosed controllers and remote devices and facility's central control system. Comply with requirements in Section 260523 "Control-Voltage Electrical Power Cables."
- B. Bundle, train, and support wiring in enclosures.

- C. Connect selector switches and other automatic-control selection devices where applicable.
 - 1. Connect selector switches to bypass only those manual- and automatic-control devices that have no safety functions when switch is in manual-control position.
 - 2. Connect selector switches with enclosed-controller circuit in both manual and automatic positions for safety-type control devices such as low- and high-pressure cutouts, high-temperature cutouts, and motor overload protectors.

3.5 FIELD QUALITY CONTROL

- A. Testing Agency: Engage a qualified testing agency to perform tests and inspections.
- B. Acceptance Testing Preparation:
 - 1. Test insulation resistance for each enclosed controller, component, connecting supply, feeder, and control circuit.
 - 2. Test continuity of each circuit.
- C. Tests and Inspections:
 - 1. Inspect controllers, wiring, components, connections, and equipment installation. Test and adjust controllers, components, and equipment.
 - 2. Test insulation resistance for each enclosed-controller element, component, connecting motor supply, feeder, and control circuits.
 - 3. Test continuity of each circuit.
 - 4. Verify that voltages at controller locations are within plus or minus 10 percent of motor nameplate rated voltages. If outside this range for any motor, notify Construction Manager before starting the motor(s).
 - 5. Test each motor for proper phase rotation.
 - 6. Perform each electrical test and visual and mechanical inspection stated in NETA Acceptance Testing Specification. Certify compliance with test parameters.
 - 7. Correct malfunctioning units on-site, where possible, and retest to demonstrate compliance; otherwise, replace with new units and retest.
 - 8. Perform the following infrared (thermographic) scan tests and inspections and prepare reports:
 - a. Initial Infrared Scanning: After Substantial Completion, but not more than 60 days after Final Acceptance, perform an infrared scan of each multi-pole enclosed controller. Remove front panels so joints and connections are accessible to portable scanner.
 - b. Follow-up Infrared Scanning: Perform an additional follow-up infrared scan of each multi-pole enclosed controller 11 months after date of Substantial Completion.
 - c. Instruments and Equipment: Use an infrared scanning device designed to measure temperature or to detect significant deviations from normal values. Provide calibration record for device.

9. Test and adjust controls, remote monitoring, and safeties. Replace damaged and malfunctioning controls and equipment.

D. Enclosed controllers will be considered defective if they do not pass tests and inspections.

E. Prepare test and inspection reports including a certified report that identifies enclosed controllers and that describes scanning results. Include notation of deficiencies detected, remedial action taken, and observations after remedial action.

3.6 ADJUSTING

A. Set field-adjustable switches, auxiliary relays, time-delay relays, timers, and overload-relay pickup and trip ranges.

3.7 PROTECTION

A. Replace controllers whose interiors have been exposed to water or other liquids prior to Substantial Completion.

3.8 DEMONSTRATION

A. Engage a factory-authorized service representative to train Owner's maintenance personnel to adjust, operate, and maintain enclosed controllers.

END OF SECTION 262913