

## CLASS XII

*There will be two papers in the subject:*

**Paper I - Theory: 3 hours..... 80 Marks**

**Paper II - Project Work ..... 20 Marks**

### PAPER I (THEORY): 80 MARKS

#### Drawing (Engineering)

Candidates will be required to answer **all** questions.

The preparation of working drawings and assemblies from dimensioned sketches based on the following:

- (a) fastening (nuts, bolts, studs, keys, cotters, pins, locking devices);
- (b) rigid and flexible joints;
- (c) screw threads; their projection and the proportions of standard types, profiles and proportions of spur gear teeth; conventional methods of drawing gear wheels;
- (d) transmission of motion and power, bearings, supports, shafts, coupling and clutches;
- (e) pressure transmission in pipes using water, oil, steam and gas, joints, unions, tees and bends, expansion joints, pressure packing;
- (f) constructional details of prime moves and simple machine tools;
- (g) the use of reference points and planes in dimensioning, machining and surface texture symbols;
- (h) toleranced dimensions involving the use of IS:919 or B.S. 4500 Limits and Fits for Engineering.

Candidates will be expected to follow the recommendations given in IS:696 - 1972 Indian Standard, Code of Practice for General Engineering Drawing. They should be familiar with both First and Third Angle projections.

### PAPER II (PROJECT WORK): 20 Marks

In addition to the syllabus prescribed above, candidates are also required to be assessed in Project Work.

All candidates will be required to have completed **three** project sheets, selecting at least **one** from Section A (Orthographic Projections) and **one** from Section B (Assembly Drawings). **Each** Project sheet will carry **5 Marks**.

The Project work will be assessed by the subject teacher and the Visiting Examiner appointed locally and approved by the Council.

#### Mark allocation for *each* Project sheet (5 marks)\*:

	Criteria	Marks
1.	Project size / completeness	1
2.	Line Quality	1
3.	Neatness	1
4.	Accuracy	1
5.	Title Block	1
<b>TOTAL</b>		<b>5</b>

#### Marks out of 20 will be distributed as given below:

1.	3 Project sheets × 5 Marks	15 Marks
2.	Viva-Voce (Visiting Examiner)	5 Marks
<b>TOTAL</b>		<b>20 Marks</b>

### Instructions for Project Work:

- Candidates must use A2 size (**Half Imperial**) drawing sheets to complete all projects. A sample project sheet layout with specifications, is given below:

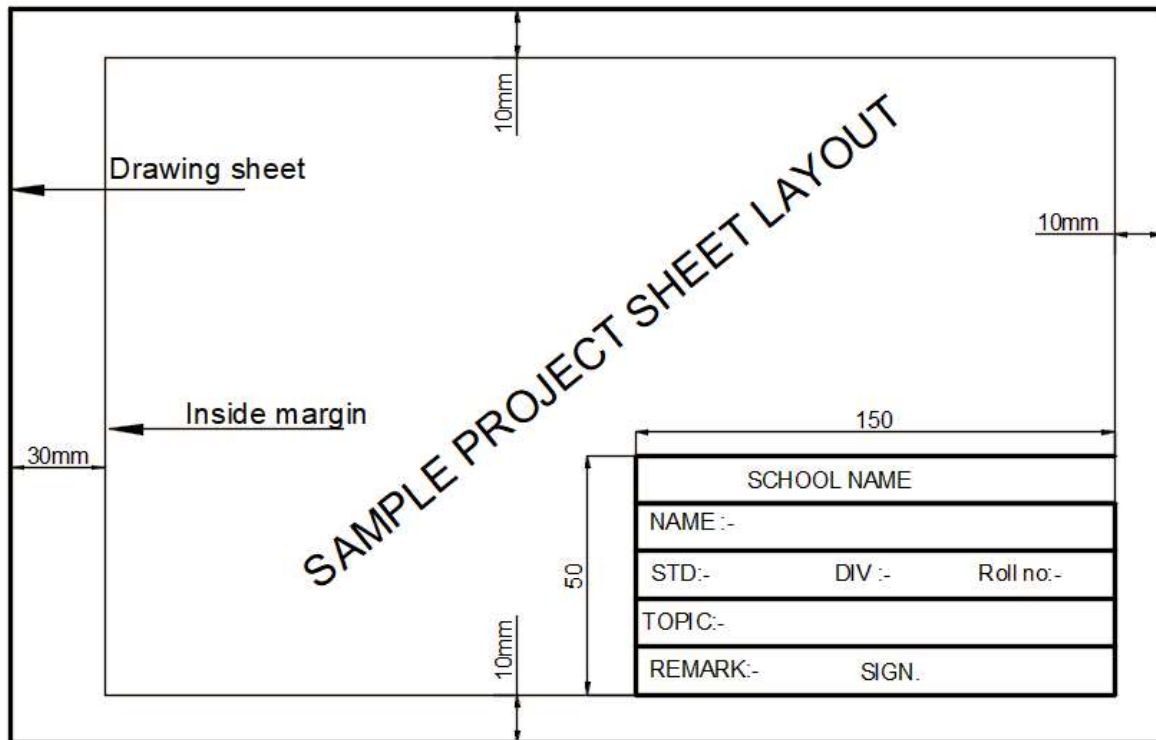

- Candidates must use the given layout and specifications to complete each project sheet.
- Accuracy, neat and clean work is expected from candidates while completing the project sheets.
- Candidates need **not** draw / paste the questions.
- For assembly drawing, candidates need to draw:
  - Full sectional F.V.
  - T.V. by using 1<sup>st</sup> OR 3<sup>rd</sup> angle method of projection (omitting all the hidden lines)

## PROJECT SHEETS

Candidates are required to have completed **three** project sheets, selecting at least **one** from **Section A** (Orthographic Projections) and **one** from **Section B** (Assembly Drawings).

### SECTION A - ORTHOGRAPHIC PROJECTIONS

#### Project Sheet 1

Draw by using 1<sup>st</sup> OR 3<sup>rd</sup> angle method of projection i) F.V, ii) T.V. & iii) L.H.S.V

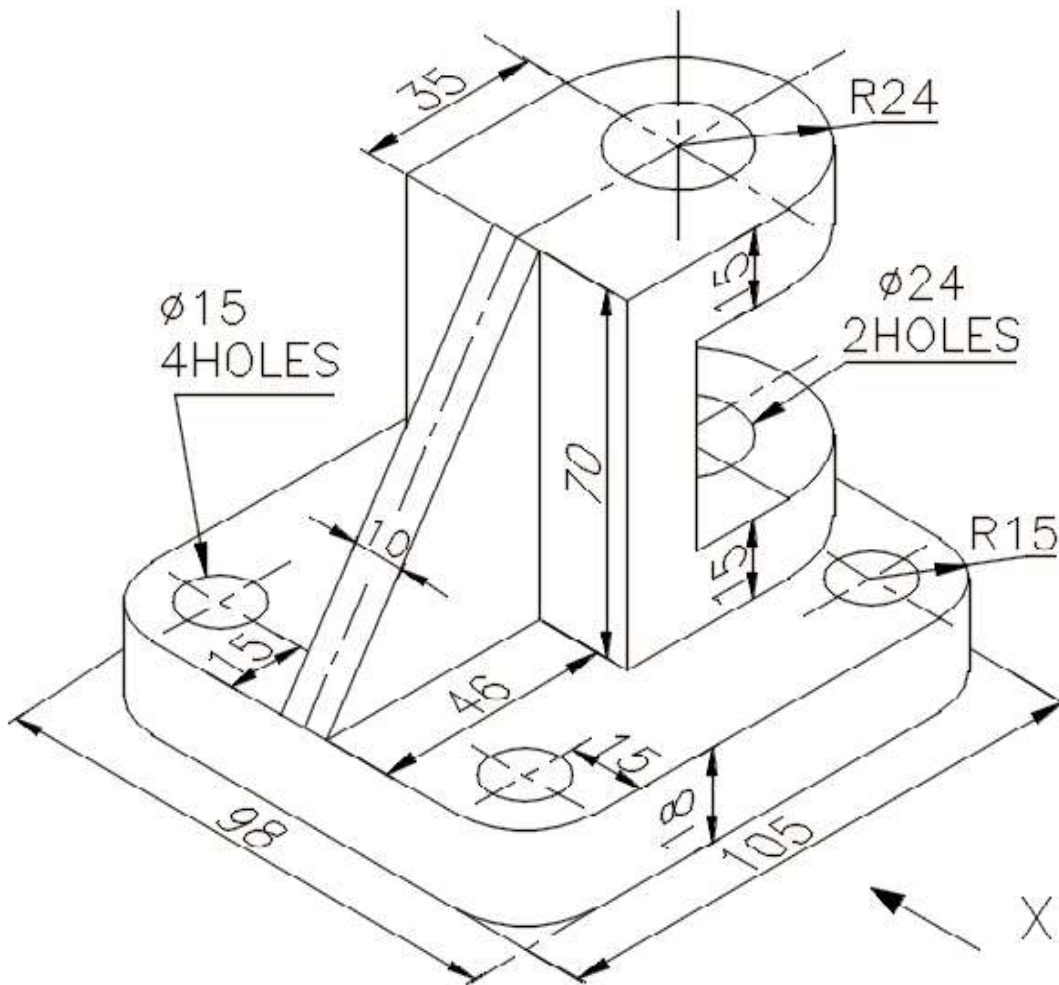

**Project Sheet 2**

Draw by using 1<sup>st</sup> OR 3<sup>rd</sup> angle method of projection i) F.V, ii) T.V. & iii) R.H.S.V

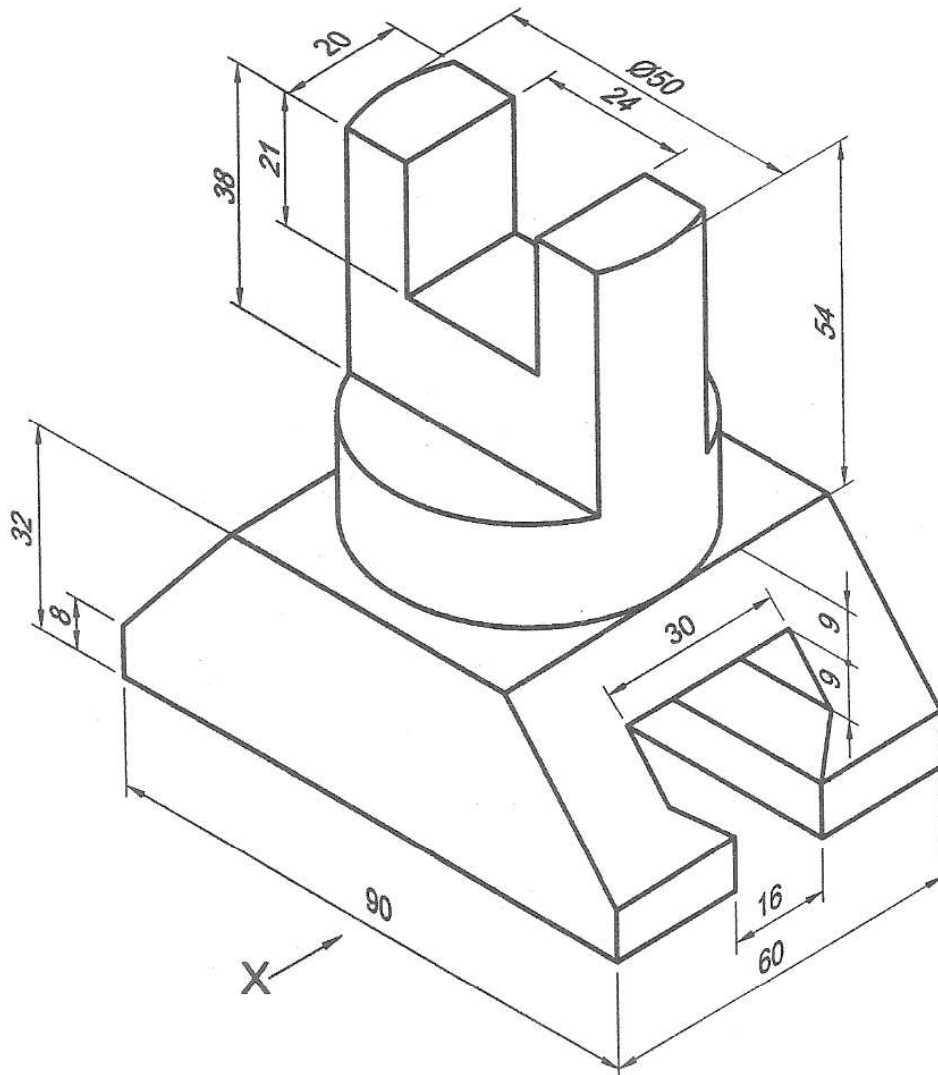

**Project Sheet 3**

Draw by using 1<sup>st</sup> OR 3<sup>rd</sup> angle method of projection i) F.V, ii) T.V. & iii) L.H.S.V

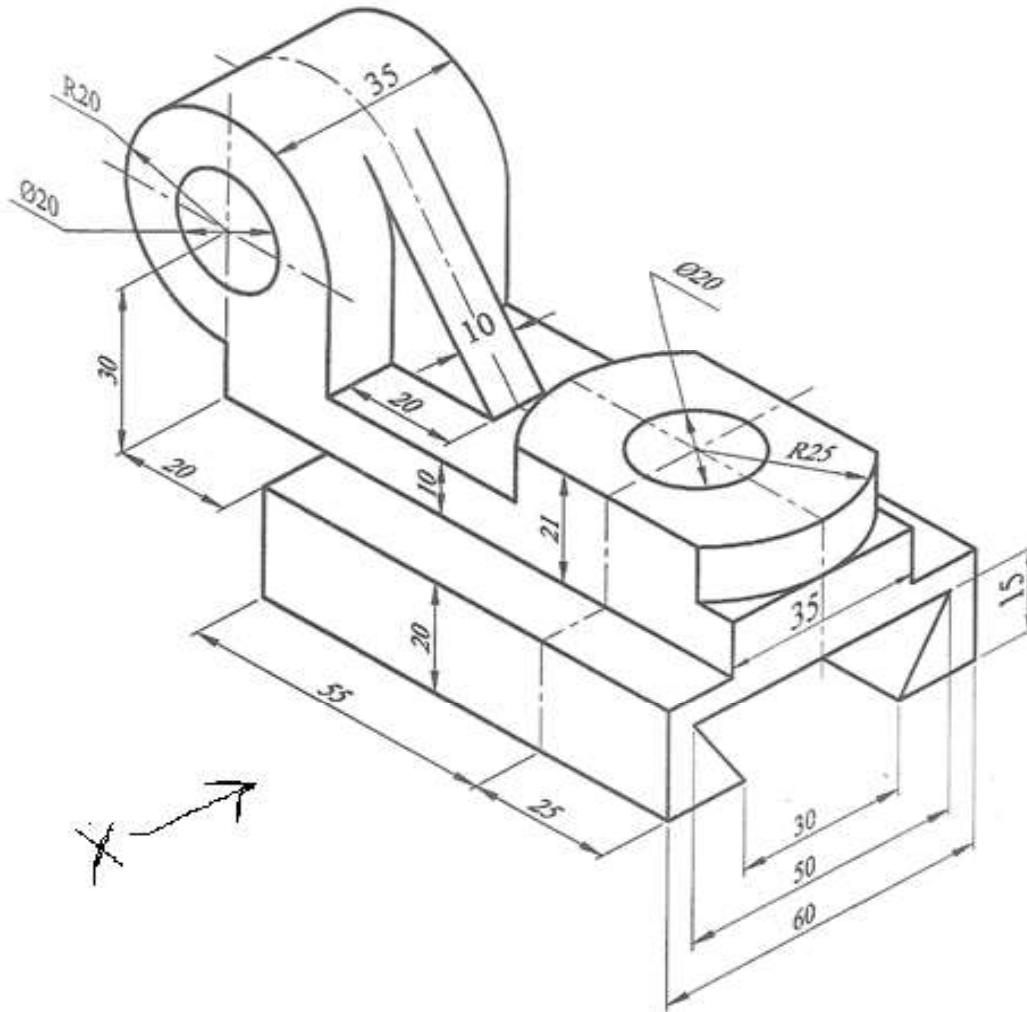

**Project Sheet 4**

Draw by using 1<sup>st</sup> OR 3<sup>rd</sup> angle method of projection i) F.V, ii) T.V. & iii) L.H.S.V

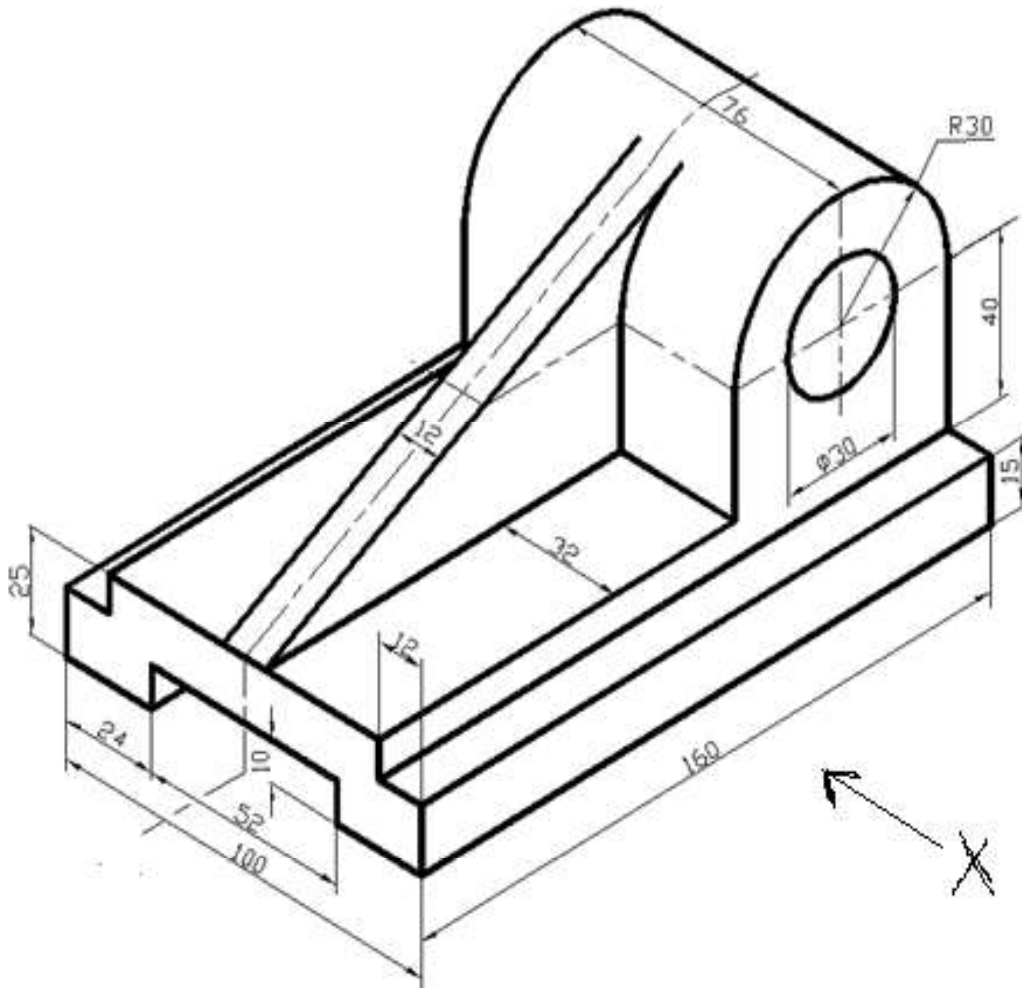

**SECTION B - ASSEMBLY DRAWINGS**

**Project Sheet 1**

Draw full sectional F.V & T.V of the following details of machine Parts. (omitting all hidden details)

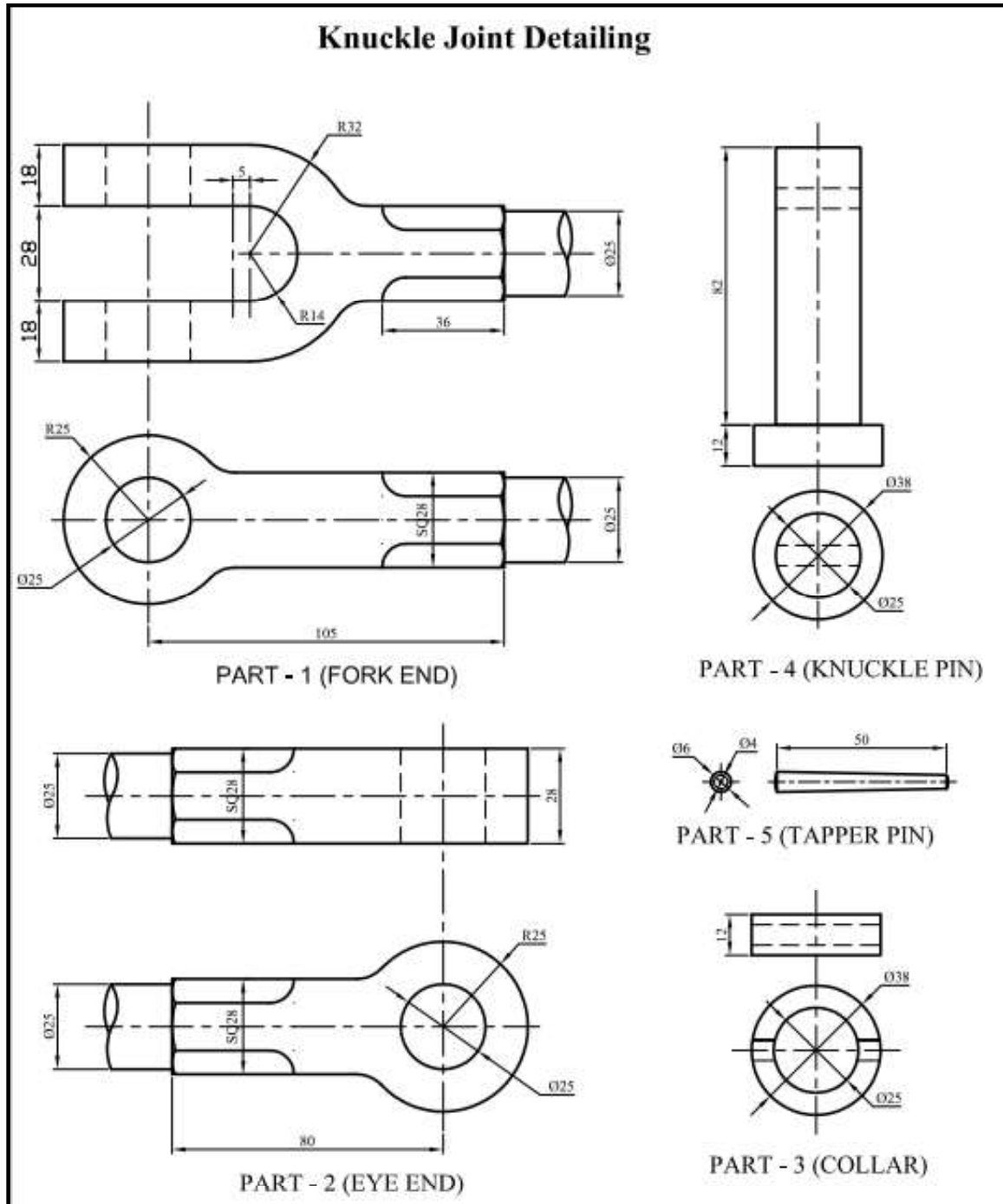

**Project Sheet 2**

Draw full sectional F.V. & T.V. of the following details of machine Parts. (omitting all hidden details)

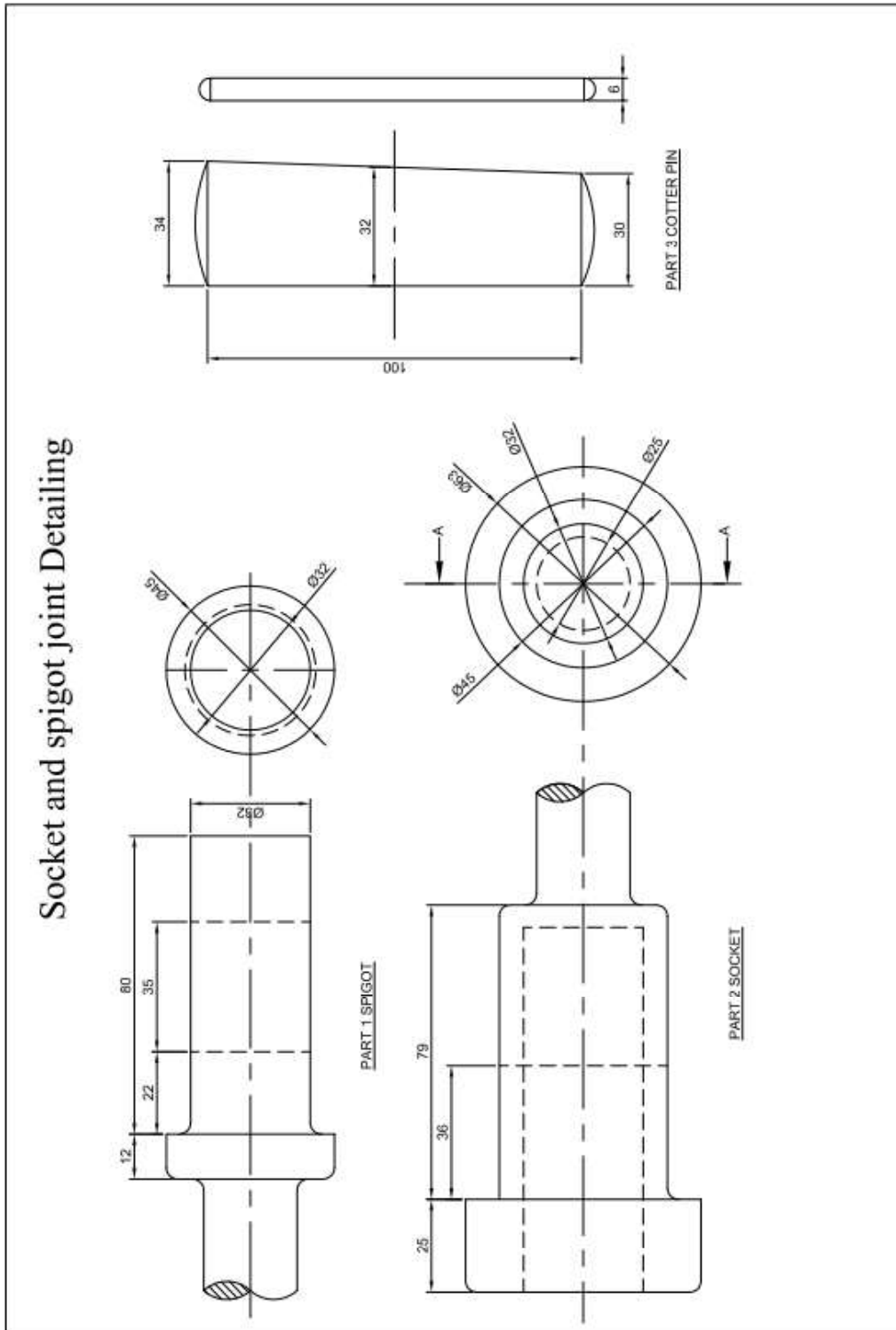



**Project Sheet 3**

Draw full sectional F.V & T.V of the following details of machine Parts. (omitting all hidden details)

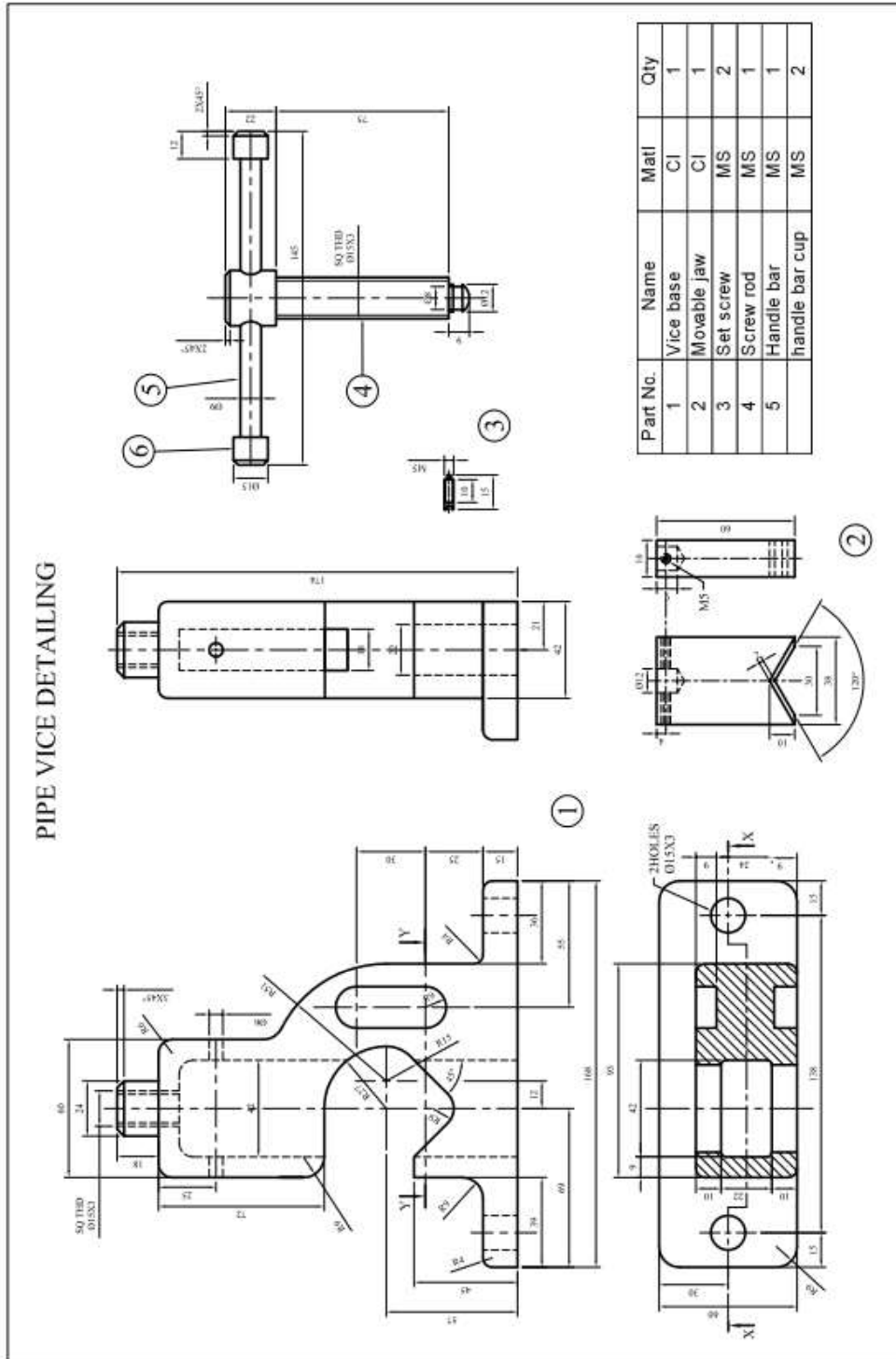

**Project Sheet 4**

Draw full sectional F.V & T.V of the following details of machine Parts. (omitting all hidden details)

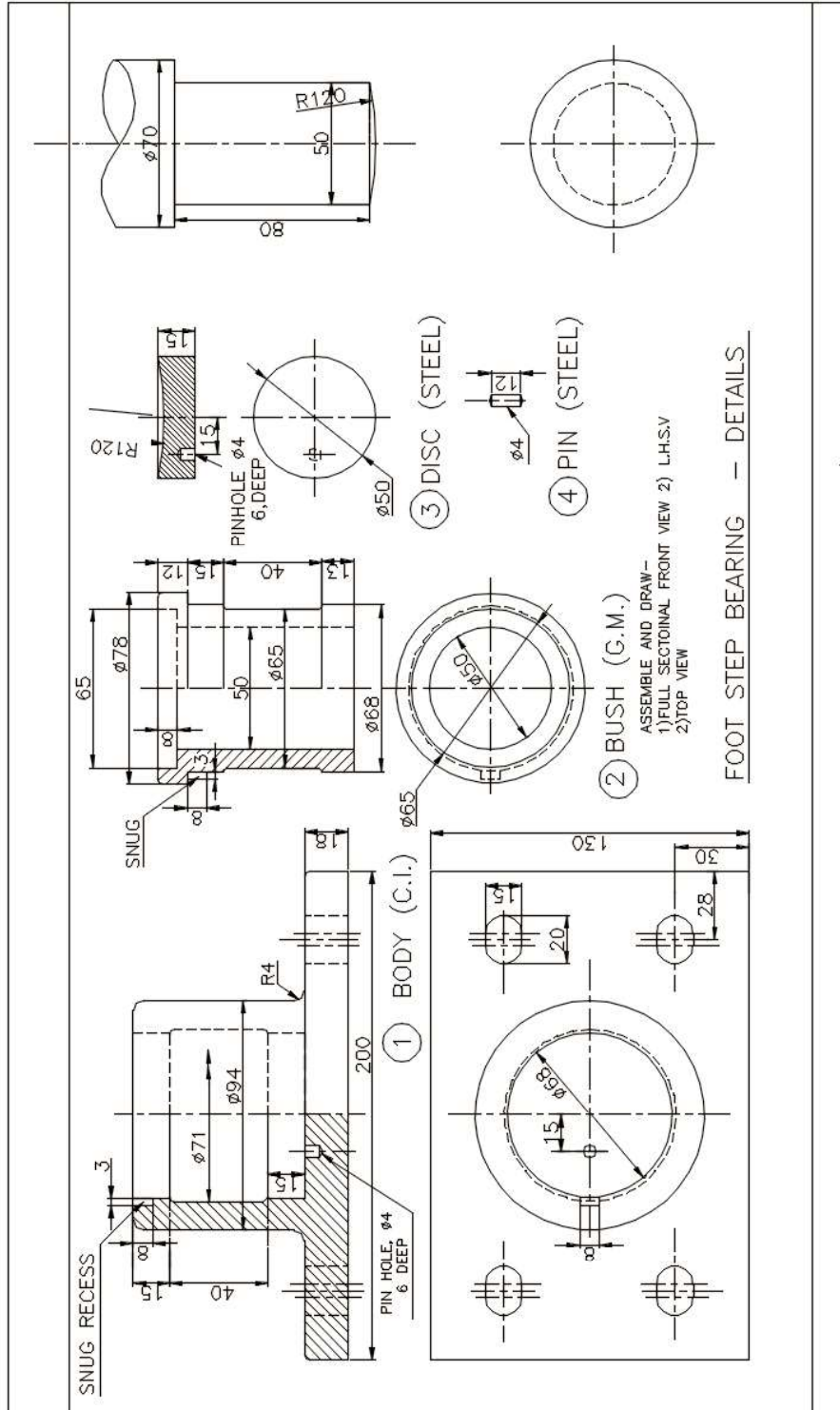

### SAMPLE TABLE FOR PROJECT WORK

S. No.	Unique Identification Number (Unique ID) of the candidate	PROJECT SHEETS (Total 3 sheets of 5 marks each)			TOTAL MARKS	
		A	B	C		D
		Teacher	Visiting Examiner	Average Marks (A + B ÷ 2)	Viva-Voce by Visiting Examiner on all three project sheets	(C + D)
		15 Marks	15 Marks	15 Marks	5 Marks	20 Marks
1						
2						
3						
4						
5						
6						
7						
8						
9						
10						

\*For breakup of the 5 Marks (for each project sheet) to be awarded separately by the Teacher and the Visiting Examiner, please refer to the table giving the criteria for mark allocation for *each* project.

**NOTE: VIVA-VOCE of 5 Marks on the Project Sheets is to be conducted only by the Visiting Examiner and should be based on the Project Sheets only.**