

JEE Main 2020 Paper



Date of Exam: 7th January (Shift II)

Time: 2:30 pm – 5:30 pm

Subject: Physics

1. A box weighs 196 N on a spring balance at the North Pole. Its weight recorded on the same balance if it is shifted to the equator is close to (Take $g = 10 \text{ m/s}^2$ at the North Pole and radius of the Earth = 6400 km)

- a. 194.32 N
- b. 194.66 N
- c. 195.32 N
- d. 195.66 N

Solution: (c)

Weight of the object at the pole, $W = mg = 196 \text{ N}$

Mass of the object, $m = \frac{W}{g} = \frac{196}{10} = 19.6 \text{ kg}$

Weight of object at the equator (W') = Weight at pole – Centrifugal acceleration

$$W' = mg - m\omega^2 R$$

$$W' = 196 - (19.6) \left(\frac{2\pi}{24 \times 3600} \right)^2 \times 6400 \times 10^3 = 195.33 \text{ N}$$

2. In a building, there are 15 bulbs of 45 W, 15 bulbs of 100 W, 15 small fans of 10 W and 2 heaters of 1 kW. The voltage of electric main is 220 V. The minimum fuse capacity (rated value) of the building will be approximately

- a. 10 A
- b. 20 A
- c. 25 A
- d. 15 A

Solution: (b)

Total power consumption of the house (P) = Number of appliances \times Power rating of each appliance

$$P = (15 \times 45) + (15 \times 100) + (15 \times 10) + (2 \times 1000) = 4325 \text{ W}$$

So, minimum fuse current $I = \frac{\text{Total power consumption}}{\text{Voltage supply}} = \frac{4325}{220} \text{ A} = 19.66 \text{ A}$



3. Under an adiabatic process, the volume of an ideal gas gets doubled. Consequently, the mean collision time between the gas molecules changes from τ_1 to τ_2 . If $\frac{C_p}{C_v} = \gamma$ for this gas, then a good estimate for $\frac{\tau_2}{\tau_1}$ is given by
- a. $\frac{1}{2}$
 - b. $\left(\frac{1}{2}\right)^{\frac{\gamma+1}{2}}$
 - c. $\left(\frac{1}{2}\right)^\gamma$
 - d. 2

Solution: (challenge question)

Relaxation time (τ) dependence on volume and temperature can be given by $\tau \propto \frac{V}{\sqrt{T}}$

Also, for an adiabatic process,

$$T \propto \frac{1}{V^{\gamma-1}}$$

$$\Rightarrow \tau \propto V^{\frac{1+\gamma}{2}}$$

Thus,

$$\frac{\tau_2}{\tau_1} = \left(\frac{2V}{V}\right)^{\frac{1+\gamma}{2}}$$

$$\frac{\tau_2}{\tau_1} = (2)^{\frac{1+\gamma}{2}}$$

4. A mass of 10 kg is suspended by a rope of length 4 m , from the ceiling. A force F is applied horizontally at the mid-point of the rope such that the top half of the rope makes an angle of 45° with the vertical. Then F equals (Take $g = 10\text{ m/s}^2$ and rope to be massless)
- a. 100 N
 - b. 90 N
 - c. 75 N
 - d. 70 N

Solution: (a)

Equating the vertical and horizontal components of the forces acting at point

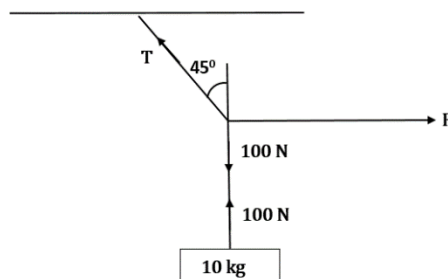



$$\frac{T}{\sqrt{2}} = 100$$

$$\frac{T}{\sqrt{2}} = F$$

$$F = 100 \text{ N}$$

5. Mass per unit area of a circular disc of radius a depends on the distance r from its centre as $\sigma(r) = A + Br$. The moment of inertia of the disc about the axis, perpendicular to the plane and passing through its centre is

a. $2\pi a^4 \left(\frac{A}{4} + \frac{aB}{5}\right)$

b. $2\pi a^4 \left(\frac{aA}{4} + \frac{B}{5}\right)$

c. $\pi a^4 \left(\frac{A}{4} + \frac{aB}{5}\right)$

d. $2\pi a^4 \left(\frac{A}{4} + \frac{B}{5}\right)$

Solution: (a)

$$\sigma = A + Br$$

$$\int dm = \int (A + Br) 2\pi r dr$$

$$I = \int dm r^2$$

$$= \int_0^a (A + Br) 2\pi r^3 dr$$

$$= 2\pi \left(A \frac{a^4}{4} + B \frac{a^5}{5} \right)$$

$$= 2\pi a^4 \left(\frac{A}{4} + \frac{Ba}{5} \right)$$

6. Two ideal Carnot engines operate in cascade (all heat given up by one engine is used by the other engine to produce work) between temperatures T_1 and T_2 . The temperature of the hot reservoir of the first engine is T_1 and the temperature of the cold reservoir of the second engine is T_2 . T is the temperature of the sink of first engine which is also the source for the second engine. How is T related to T_1 and T_2 if both the engines perform equal amount of work?

a. $T = \frac{2T_1 T_2}{T_1 + T_2}$

b. $T = \frac{T_1 + T_2}{2}$

c. $T = 0$

d. $T = \sqrt{T_1 T_2}$

Solution: (b)

Heat input to 1st engine = Q_H

Heat rejected from 1st engine = Q

Heat rejected from 2nd engine = Q_L

Work done by 1st engine = Work done by 2nd engine

$$Q_H - Q = Q - Q_L$$

$$2Q = Q_H + Q_L$$

$$2 = \frac{T_1}{T} + \frac{T_2}{T}$$

$$T = \frac{T_1 + T_2}{2}$$

7. The activity of a radioactive substance falls from 700 s^{-1} to 500 s^{-1} in 30 minutes. Its half-life is close to
- a. 66 min
 - b. 62 min
 - c. 52 min
 - d. 72 min

Solution: (b)

Using the half-life equation,

$$\ln \frac{A_0}{A_t} = \lambda t$$

At half-life, $t = t_{\frac{1}{2}}$ and $A_t = \frac{A_0}{2}$

$$\Rightarrow \ln 2 = \lambda t_{\frac{1}{2}} \text{ ----- (1)}$$

Also given

$$\ln \frac{700}{500} = \lambda (30) \text{ ----- (2)}$$

Dividing the equations,

$$\frac{\ln 2}{\ln \left(\frac{7}{5}\right)} = \frac{t_{\frac{1}{2}}}{30}$$

$$\Rightarrow t_{\frac{1}{2}} = 61.8 \text{ minutes}$$

8. In a Young's double slit experiment, the separation between the slits is 0.15 mm . In the experiment, a source of light of wavelength 589 nm is used and the interference pattern is observed on a screen kept 1.5 m away. The separation between the successive bright fringes on the screen is
- a. 5.9 mm
 - b. 3.9 mm
 - c. 6.9 mm
 - d. 4.9 mm

Solution: (a)

$$\beta = \lambda \frac{D}{d} = \frac{589 \times 10^{-9} \times 1.5}{0.15 \times 10^{-3}}$$

$$= 5.9 \text{ mm}$$

9. An ideal fluid flows (laminar flow) through a pipe of non-uniform diameter. The maximum and minimum diameters of the pipes are 6.4 cm and 4.8 cm , respectively. The ratio of minimum and maximum velocities of fluid in this pipe is

a. $\sqrt{\frac{3}{2}}$
 c. $\frac{3}{4}$

b. $\frac{9}{16}$
 d. $\frac{3}{4}$

Solution: (b)

Given,

Maximum diameter of pipe = 6.4 cm

Minimum diameter of pipe = 4.8 cm

Using equation of continuity

$$A_1 V_1 = A_2 V_2$$

$$\frac{V_1}{V_2} = \frac{A_2}{A_1} = \left(\frac{4.8}{6.4}\right)^2 = \frac{9}{16}$$

10. In the figure, potential difference between a and b is

a. 0 V
 c. 10 V

b. 15 V
 d. 5 V

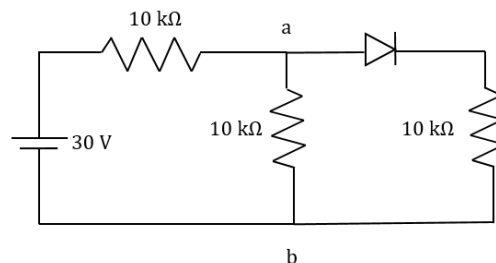

Solution:

(c)

Diode is in forward bias, so it will behave as simple wire. So, the circuit effectively becomes

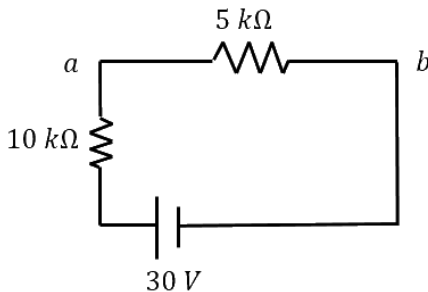

$$V_{ab} = \frac{30}{5+10} \times 5 = 10 \text{ V}$$

11. A particle of mass m and charge q has an initial velocity $\vec{v} = v_0 \hat{j}$. If an electric field $\vec{E} = E_0 \hat{i}$ and magnetic field $\vec{B} = B_0 \hat{i}$ act on the particle, its speed will double after a time

- | | |
|---|--|
| a. $\frac{\sqrt{3}mv_0}{qE_0}$
c. $\frac{3mv_0}{qE_0}$ | b. $\frac{\sqrt{2}mv_0}{qE_0}$
d. $\frac{2mv_0}{2qE_0}$ |
|---|--|

Solution: (a)

Magnetic field can only change direction of speed as it cannot do any work

As $\vec{v} = v_0 \hat{j}$ (magnitude of velocity does not change in y - z plane)

$$(2v_0)^2 = v_0^2 + v_x^2$$

$$v_x = \sqrt{3}v_0$$

$$\therefore \sqrt{3}v_0 = 0 + \frac{qE_0}{m}t \Rightarrow t = \frac{mv_0\sqrt{3}}{qE_0}$$

12. A stationary observer receives sound from two identical tuning forks, one of which approaches and the other one receded with the same speed (much less than the speed of sound). The observer hears 2 beats/sec. The oscillation frequency of each tuning fork is $\nu_0 = 1400 \text{ Hz}$ and the velocity of sound in air is 350 m/s . The speed of each tuning fork is close to

- | | |
|--|--|
| a. $\frac{1}{4} \text{ m/s}$
c. $\frac{1}{2} \text{ m/s}$ | b. 1 m/s
d. $\frac{1}{8} \text{ m/s}$ |
|--|--|

Solution: (a)

$$f_0 \left(\frac{C}{C-V} \right) - f_0 \left(\frac{C}{C+V} \right) = 2$$

$$V = \frac{1}{4} \text{ m/s}$$



- a. zero
 b. antiparallel to $\frac{i+j}{\sqrt{2}}$
 c. parallel to $\frac{i+j}{\sqrt{2}}$
 d. parallel to \hat{k}

Solution: (b)

Force due to electric field is in direction $-\frac{i+j}{\sqrt{2}}$

Because at $t = 0, E = -\frac{(i+j)}{\sqrt{2}} E_0$

Force due to magnetic field is in direction $q(\vec{v} \times \vec{B})$ and $\vec{v} \parallel \hat{k}$

\therefore It is parallel to \vec{E}

\therefore Net force is antiparallel to $\frac{(i+j)}{\sqrt{2}}$.

16. A thin lens made of glass (refractive index = 1.5) of focal length $f = 16 \text{ cm}$ is immersed in a liquid of refractive index 1.42. If its focal length in liquid is f_l , then the ratio f_l/f is closest to the integer

- a. 9
 b. 17
 c. 1
 d. 5

Solution:

(a)

$$\frac{1}{f_a} = \left(\frac{\mu_g}{\mu_a} - 1\right) \left(\frac{1}{R_1} - \frac{1}{R_2}\right)$$

$$\frac{1}{f_l} = \left(\frac{\mu_g}{\mu_m} - 1\right) \left(\frac{1}{R_1} - \frac{1}{R_2}\right)$$

$$\Rightarrow \frac{f_a}{f_l} = \frac{\left(\frac{\mu_g}{\mu_l} - 1\right)}{\left(\frac{\mu_g}{\mu_a} - 1\right)} = \frac{\left(\frac{1.50}{1.42} - 1\right)}{\left(\frac{1.50}{1} - 1\right)} = \frac{0.08}{(1.42)(0.5)}$$

$$\frac{f_l}{f_a} = \frac{(1.42)(0.5)}{0.08} = 8.875 = 9$$

17. An elevator in a building can carry a maximum of 10 persons, with the average mass of each person being 68 kg . The mass of the elevator itself is 920 kg and it moves with a constant speed of 3 m/s . The frictional force opposing the motion is 6000 N . If the elevator is moving up with its full capacity, the power delivered by the motor to the elevator ($g = 10 \text{ m/s}^2$) must be at least

- a. 66000 W
 b. 63360 W
 c. 48000 W
 d. 56300 W

Solution: (a)

Net force on motor will be



19. An emf of 20 V is applied at time $t = 0$ to a circuit containing in series 10 mH inductor and $5\ \Omega$ resistor. The ratio of the currents at time $t = \infty$ and $t = 40\text{ s}$ is close to (take $e^2 = 7.389$)

- a. 1.06
- b. 1.46
- c. 1.15
- d. 0.84

Solution: (a)

$$\begin{aligned}
 i &= i_0 \left(1 - e^{-t/LR}\right) \\
 &= \frac{20}{5} \left(1 - e^{-t/0.01/5}\right) \\
 &= 4(1 - e^{-500t}) \\
 i_\infty &= 4
 \end{aligned}$$

$$i_{40} = 4(1 - e^{-500 \times 40}) = 4 \left(1 - \frac{1}{(e^2)^{10000}}\right) = 4 \left(1 - \frac{1}{7.389^{10000}}\right)$$

$$\frac{i_\infty}{i_{40}} \approx 1 \text{ (Slightly greater than one)}$$

20. The dimension of $\frac{B^2}{2\mu_0}$, where B is magnetic field and μ_0 is the magnetic permeability of vacuum, is

- a. $ML^{-1}T^{-2}$
- b. ML^2T^{-2}
- c. MLT^{-2}
- d. ML^2T^{-1}

Solution: (a)

Energy density in magnetic field = $\frac{B^2}{2\mu_0}$

$$= \frac{\text{Force} \times \text{displacement}}{(\text{displacement})^3} = \frac{MLT^{-2} \cdot L}{L^3} = ML^{-1}T^{-2}$$

21. A 60 pF capacitor is fully charged by a 20 V supply. It is then disconnected from the supply and is connected to another uncharged 60 pF capacitor in parallel. The electrostatic energy that is lost in this process by the time the charge is redistributed between them is (in nJ) _____.

Solution: (6)

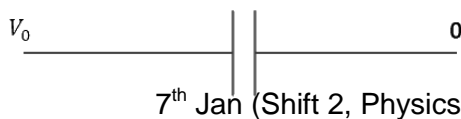

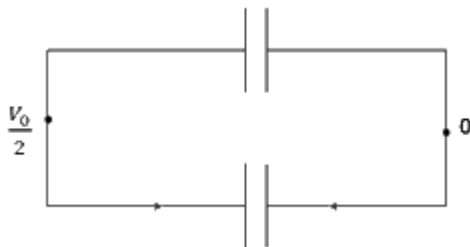

$$V_0 = 20 \text{ V}$$

$$\text{Initial potential energy } U_i = \frac{1}{2} CV_0^2$$

After connecting identical capacitor in parallel, voltage across each capacitor will be $\frac{V_0}{2}$. Then, final potential energy $U_f = 2 \left[\frac{1}{2} C \left(\frac{V_0}{2} \right)^2 \right]$

$$\text{Heat loss} = U_i - U_f$$

$$= \frac{CV_0^2}{2} - \frac{CV_0^2}{4} = \frac{CV_0^2}{4} = \frac{60 \times 10^{-12} \times 20^2}{4} = 6 \times 10^{-9} = 6 \text{ nJ}$$

22. M grams of steam at 100°C is mixed with 200 g of ice at its melting point in a thermally insulated container. If it produces liquid water at 40°C [heat of vaporization of water is 540 cal/g and heat of fusion of ice is 80 cal/g], the value of M is _____.

Solution: (40)

$$\text{Here, heat absorbed by ice} = m_{ice} L_f + m_{ice} C_w(40 - 0)$$

$$\text{Heat released by steam} = m_{steam} L_v + m_{steam} C_w(100 - 40)$$

Heat absorbed = heat released

$$m_{ice} L_f + m_{ice} C_w(40 - 0) = m_{steam} L_v + m_{steam} C_w(100 - 40)$$

$$\Rightarrow 200 \times 80 \text{ cal/g} + 200 \times 1 \text{ cal/g/}^\circ\text{C} \times (40 - 0)$$

$$= m \times 540 \text{ cal/g} + 540 \times 1 \text{ cal/g/}^\circ\text{C} \times (100 - 40)$$

$$\Rightarrow 200 [80 + (40)1] = m[540 + (60)1]$$

$$m = 40 \text{ g}$$

23. Consider a uniform cubical box of side a on a rough floor that is to be moved by applying minimum possible force F at a point b above its centre of mass (see figure). If the coefficient of friction is $\mu = 0.4$, the maximum value of $100 \times \frac{b}{a}$ for the box not to topple before moving is _____.

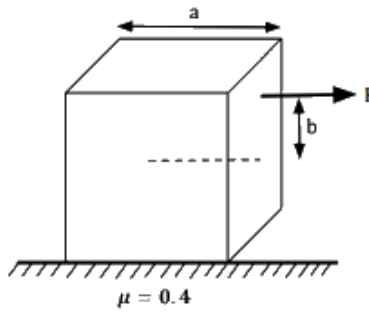

Solution: (50)

F balances kinetic friction so that the block can move

So, $F = \mu mg$

For no toppling, the net torque about bottom right edge should be zero

i.e.

$$F \left(\frac{a}{2} + b \right) \leq mg \frac{a}{2}$$

$$\mu mg \left(\frac{a}{2} + b \right) \leq mg \frac{a}{2}$$

$$\mu \frac{a}{2} + \mu b \leq \frac{a}{2}$$

$$0.2a + 0.4b \leq 0.5a$$

$$0.4b \leq 0.3a$$

$$b \leq \frac{3}{4} a$$

But, maximum value of b can only be $0.5a$

\therefore Maximum value of $100 \frac{b}{a}$ is 50.

24. The sum of two forces \vec{P} and \vec{Q} is \vec{R} such that $|\vec{R}| = |\vec{P}|$. The angle θ (in degrees) that the resultant of $2\vec{P}$ and \vec{Q} will make with \vec{Q} is _____

Solution: (90°)

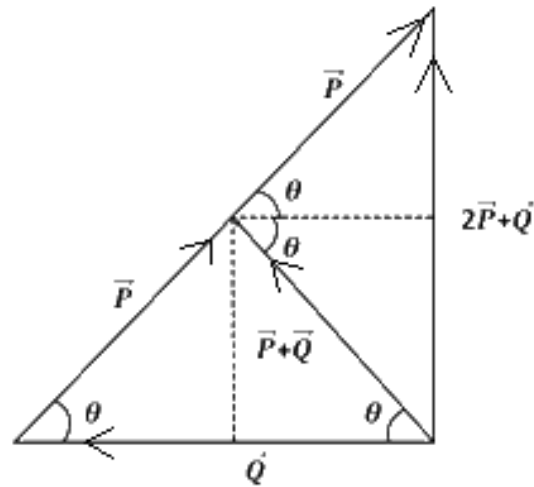

25. The balancing length for a cell is 560 cm in a potentiometer experiment. When an external resistance of $10\ \Omega$ is connected in parallel to the cell, the balancing length changes by 60 cm . If the internal resistance of the cell is $\frac{N}{10}\ \Omega$, the value of N is _____

Solution : (12)

Let the emf of cell is ε internal resistance is ' r ' and potential gradient is x .

$$\varepsilon = 560x \quad (1)$$

After connecting the resistor

$$\frac{\varepsilon \times 10}{10 + r} = 500x \quad (2)$$

From (1) and (2)

$$\frac{560 \times 10}{10 + r} = 500x$$

$$56 = 540 + 5r$$

$$r = \frac{6}{5} = 1.2\ \Omega$$

$$n = 12$$

