





! Tools required:

! Do not throw away packaging materials until assembly is complete.

! Assemble this item on a soft surface, such as cardboard or carpet, to protect finish.

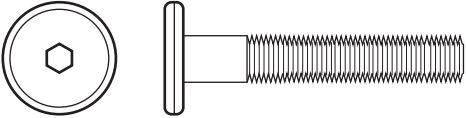
! Proper assembly of this item requires 2 people.

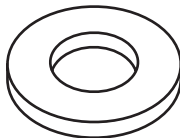
Hardware

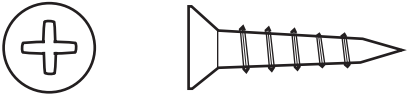
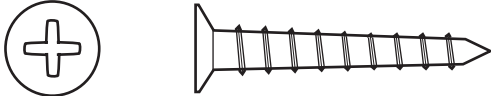
<p>A</p>  <p>6mm bolt 24x</p>	<p>B</p>  <p>spring washer 16x</p>
<p>C</p>  <p>flat washer 24x</p>	<p>D</p>  <p>adjustable levelers 8x</p>
<p>E</p>  <p>#8 x 16mm wood screw 12x</p>	<p>F</p>  <p>#8 x 25mm wood screw 12x</p>

1. First slide the table rails over the tabs on the table side frames. Insert bolt (A), spring washer (B), and flat washer (C) into holes shown in drawing. Insert only bolt (A) and flat washer (C) into bottom holes as shown. Do not tighten bolts yet. NOTE: leave the outer most holes on the bottom open.

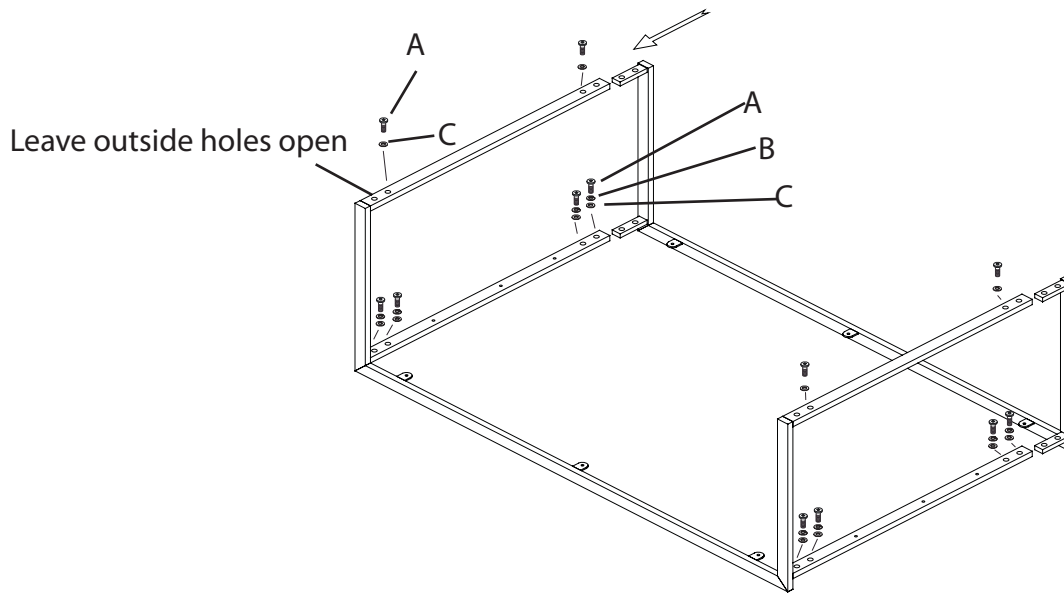

2. Insert adjustable levelers (D) into the holes left open in step 1. These levelers can be adjusted after the table is flipped over to conform to uneven flooring.

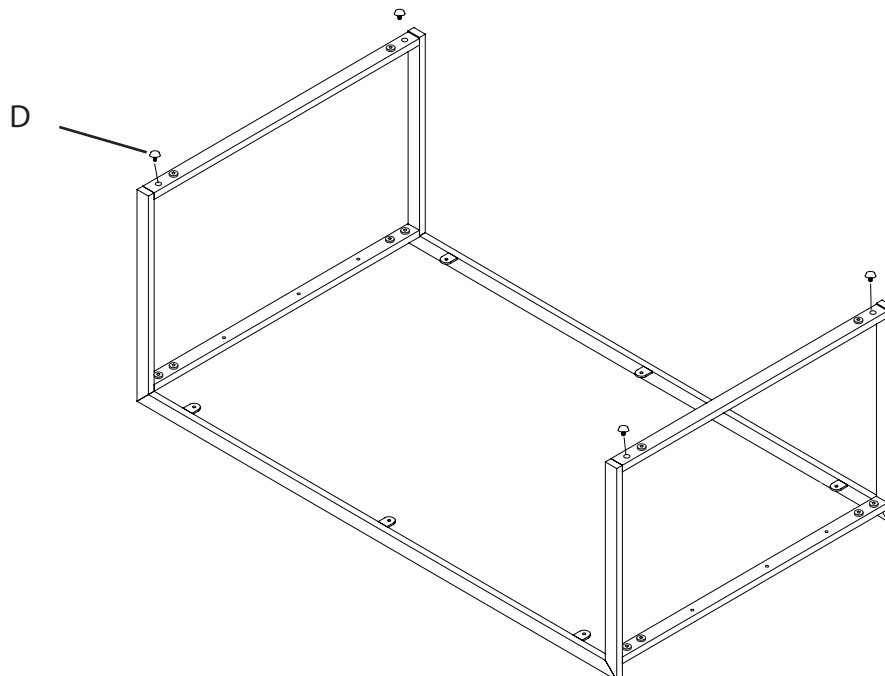

- Once the frame is assembled attach the wood top using wood screw (E) thru the side frames into the bottom of the wood top.

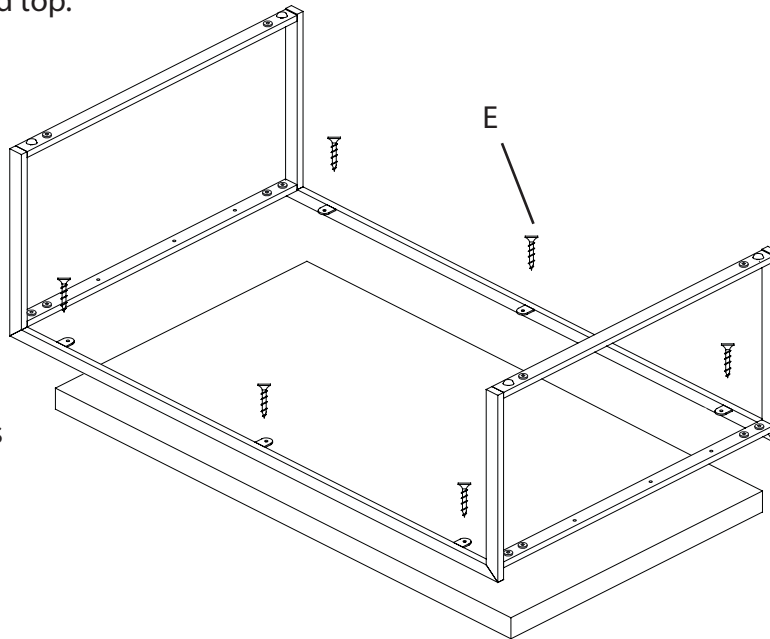

NOTE:
Thick wood top is for
large table, thin top is
for small table

- Attach the wood top using wood screw (F) thru the end rails into the bottom of the wood top. Once the wood top is attached tighten all bolts using the supplied allen key.

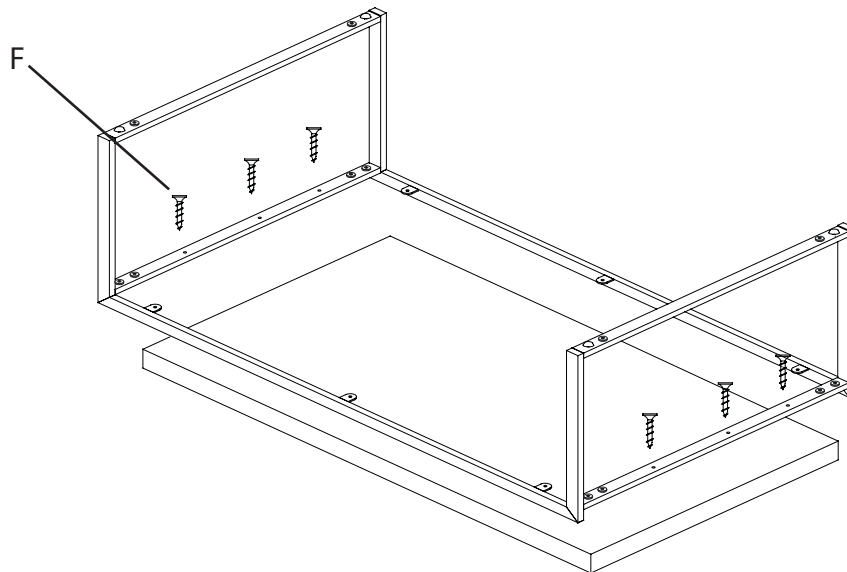

- Repeat steps 1 thru 5 for the small coffee table. Once both are assembled slide the small table under the large table.

CARE INSTRUCTIONS

Hardware may loosen overtime. Periodically check that all connections are tight.
Wipe with a soft, dry cloth. To protect finish, avoid the use of chemicals and household cleaners.