

west elm

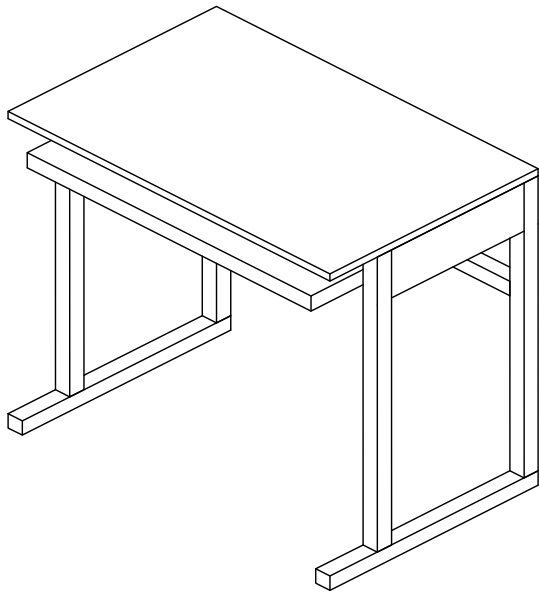



slide-away desk

assembly instructions
directives de montage
instrucciones de montaje

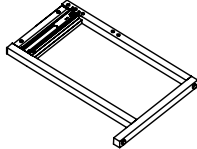
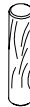
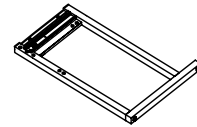

- ! Do not throw away packaging materials until assembly is complete.
- ! Assemble this item on a soft surface, such as cardboard or carpet, to protect finish.
- ! Ne jetez pas le matériel d'emballage avant d'avoir terminé le montage.
- ! Montez cet article sur une surface lisse et épaisse, telle que du carton ou un tapis, pour en protéger la finition.
- ! No deseche los materiales de embalaje hasta terminar de armar el producto.
- ! Ensamble el producto sobre una superficie suave, como cartón o alfombra, para proteger su acabado.

Parts

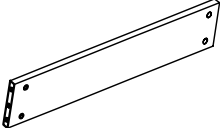
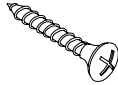
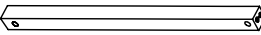
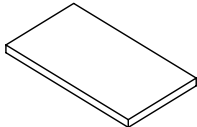
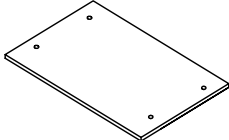
1		12PCS	A		1PC
2		10PCS	B		1PC
3		12PCS	C		1PC
4		4PCS	D		1PC
5		4PCS	E		1PC
			F		1PC
			G		1PC

west elm

slide-away desk

assembly instructions
directives de montage
instrucciones de montaje

STEP 1.

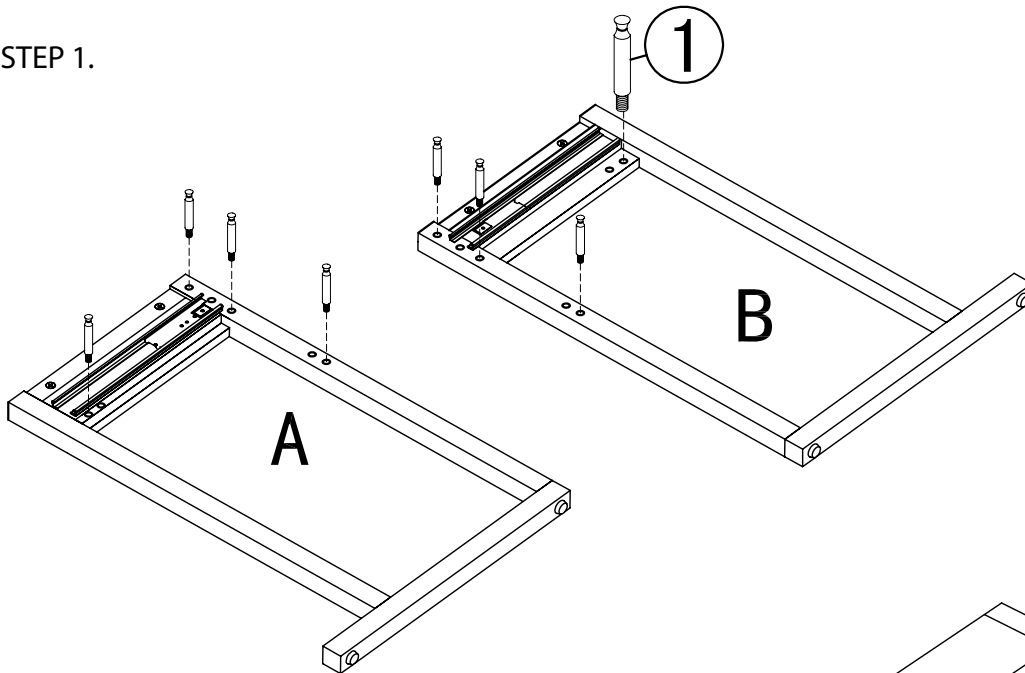

STEP 2.

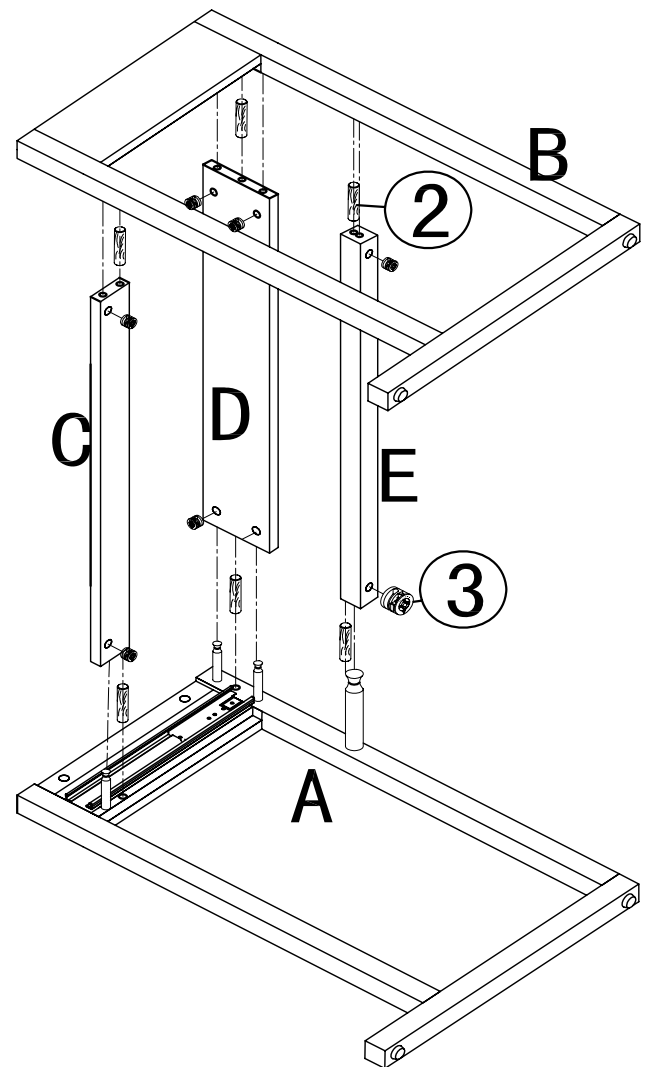

west elm

slide-away desk

assembly instructions
directives de montage
instrucciones de montaje

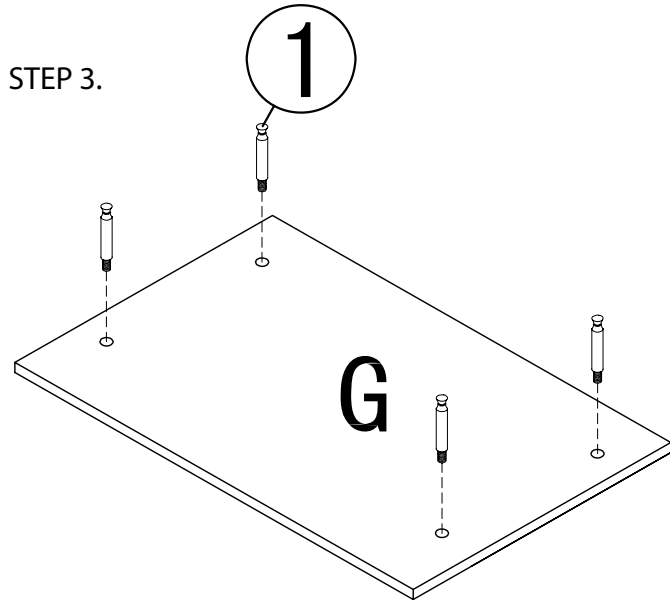

STEP 4.

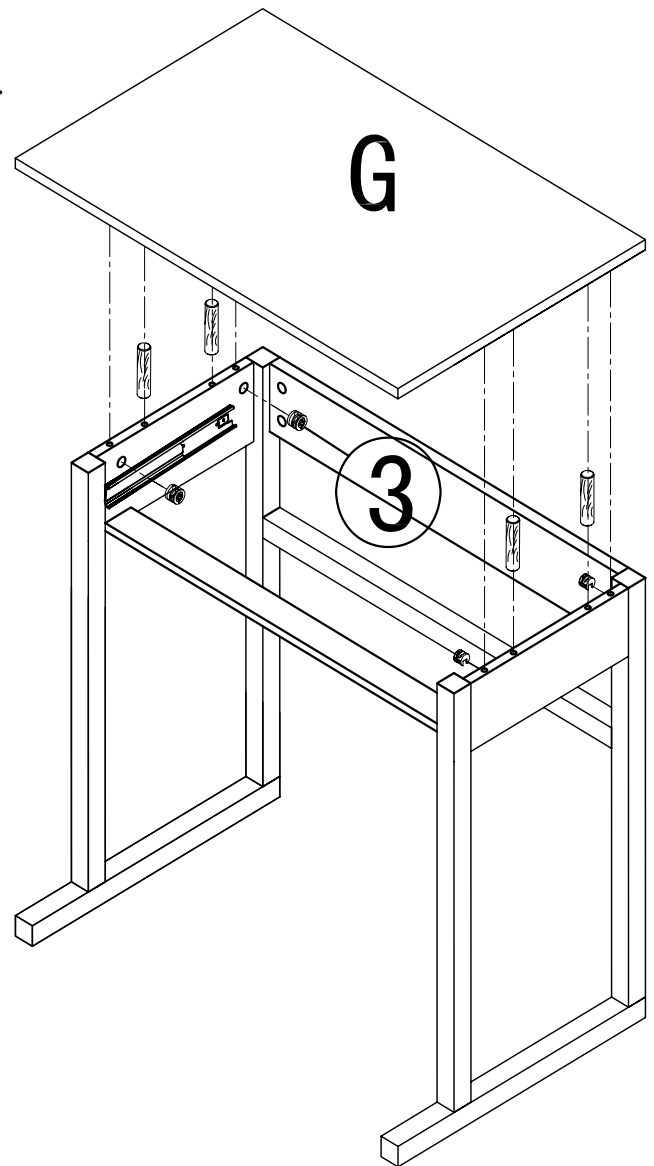

west elm

slide-away desk

assembly instructions
directives de montage
instrucciones de montaje

STEP 5

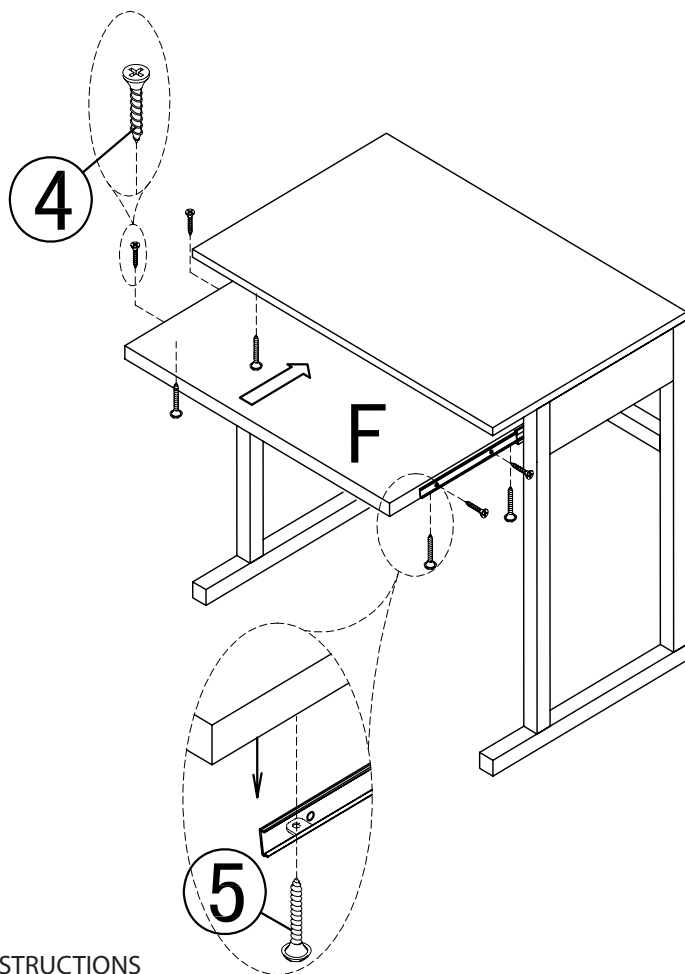
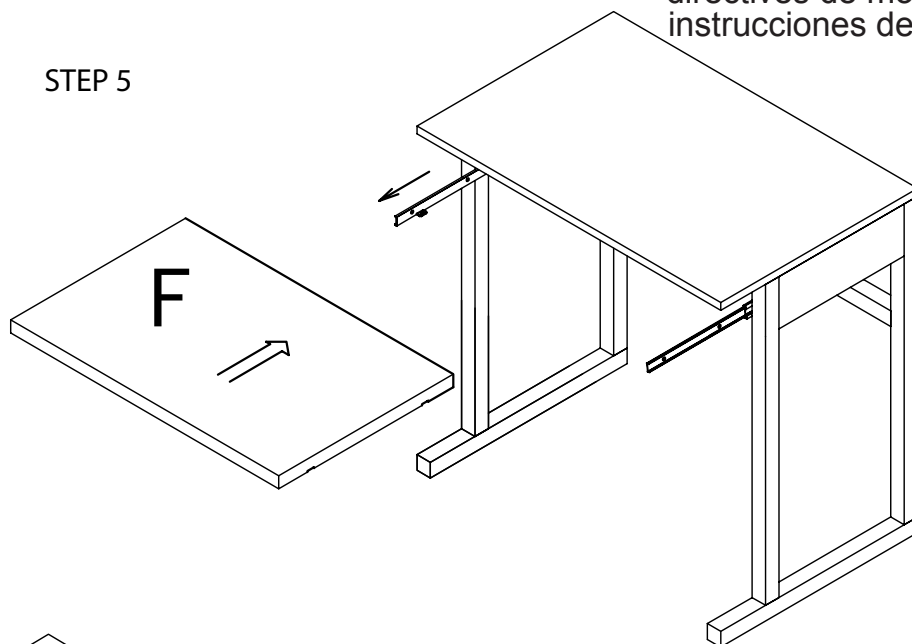

STEP 6

CARE INSTRUCTIONS

Hardware may loosen overtime. Periodically check that all connections are tight.

To protect finish, avoid the use of chemicals and household cleaners. Wipe with a soft, dry cloth.

CONSIGNES D'ENTRETIEN

Les pièces de fixation peuvent se desserrer après un certain temps. Vérifiez de temps à autre pour vous assurer que tous les raccords sont serrés.

Essayez avec un chiffon doux et sec. Pour éviter d'endommager la finition, n'utilisez pas de produits chimiques ni de nettoyants ménagers.

INSTRUCCIONES PARA EL CUIDADO DEL PRODUCTO

Los herrajes se pueden aflojar con el tiempo. Revise periódicamente que todas las conexiones estén bien apretadas.

Use un trapo suave y seco para limpiar. Para proteger el acabado, no utilice limpiadores domésticos ni productos químicos.