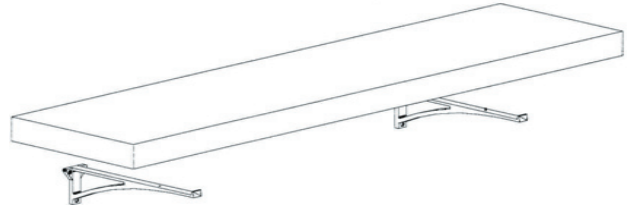
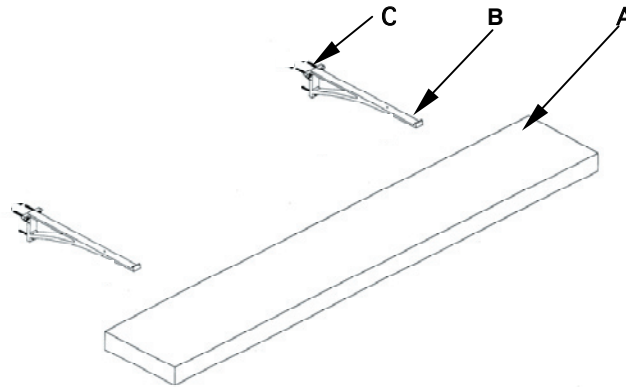

PLEASE READ FIRST

This weight limit that shelves/ledges can support depends on the surface that you mount the shelves .

Do not place heavy items on shelf unless you are sure the mounting is secure and will support the intended weight.

If you are unsure of the steps as outlined above seek the help of someone with experience of a professional to avoid damage to your wall or improper mounting of the shelf that may cause injury due to improper mounting.

**HARDWARE&PARTS**

A Shelf X 1

B Metal Bracket X 2

C Screw X 6

TOOLS NEEDED

Philips head screw driver, hammer, drill

CLEANING AND CARE:

Use a slightly damp cloth to wipe the shelf .

Do not use furniture polish since your shelf is finished with a protective lacquer.

Mounting Instruction For Wall Shelves**MOUNTING ON DRYWALL INTO STUDS**

1. Find studs in walls using a stud finder. Use the template included, and with a pencil, mark the distance between the mounting holes. Make sure the marks are level and the studs are located directly behind the marks.
2. Precisely on the marks, drill holes approximately 2" deep into the studs with a drill bit.
3. Line up the metal brackets (B) with the pre-drill holes. Insert the screws (C) through the metal bracket and into the anchors. Tighten the screws until the bracket is securely fastened to the wall.
4. Carefully place the shelf (A) onto the metal brackets.