

! Tools required:

! Do not throw away packaging materials until assembly is complete.

! Assemble this item on a soft surface, such as cardboard or carpet, to protect finish.

! Proper assembly of this item requires 2 people.

## Hardware

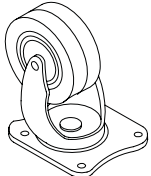
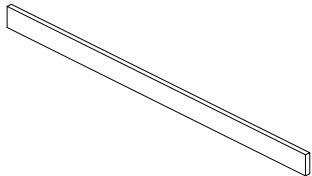
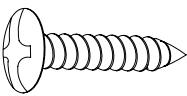
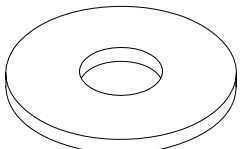
<p>A</p>  <p>casters 5x</p>	<p>B</p>  <p>file hanging bar 2x</p>
<p>C</p>  <p>screw 20x</p>	<p>D</p>  <p>flat washer 20x</p>

1. Flip mobile cabinet over onto top and place on a clean smooth surface. Align locking casters (A) with holes in bottom at front of file cabinet. Align regular castors (A) with holes towrds the back and center of the file cabinet. Attach using screw (C) and flat washer (D) with phillips head screwdriver.  
**DO NOT OVERTIGHTEN**

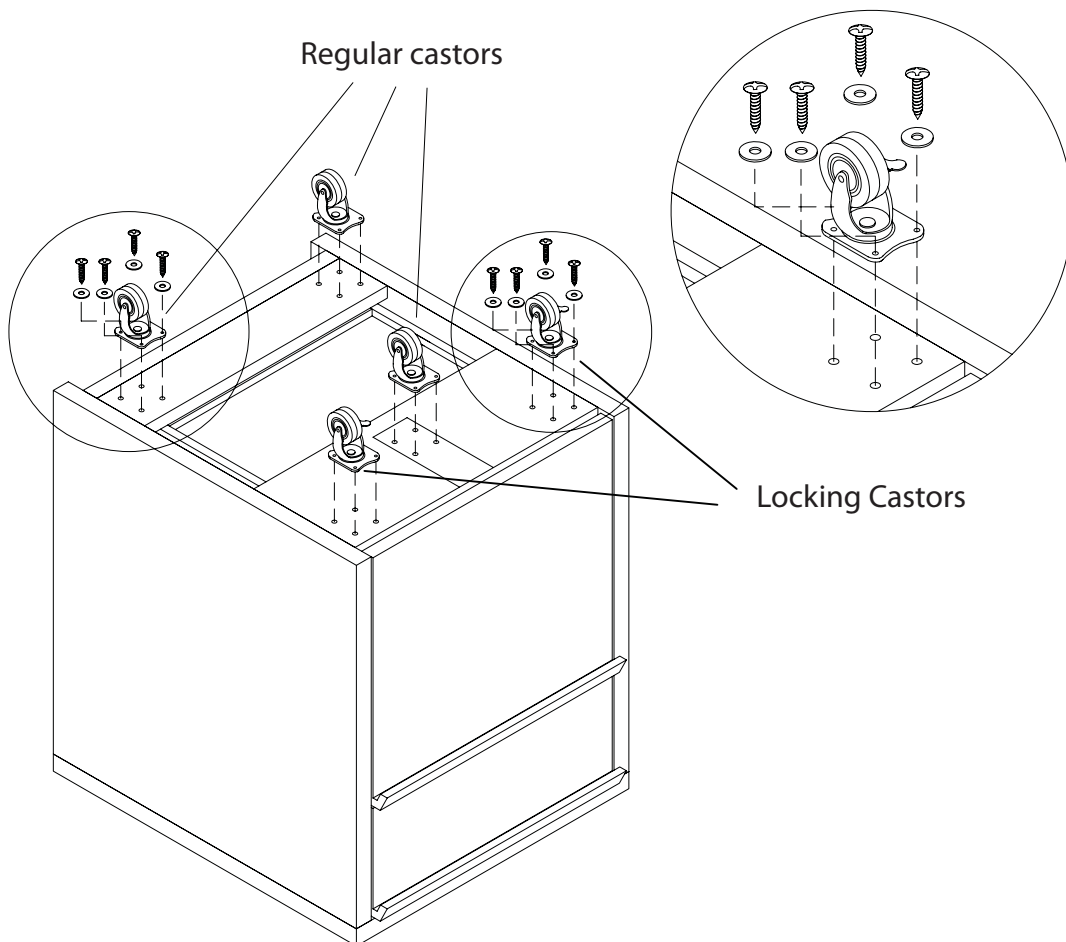
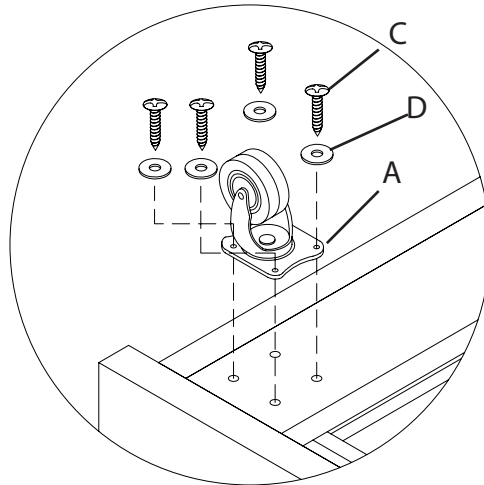

2. Flip cabinet back upright onto casters. Open bottom drawer and insert 2 file hanging bars (B) into the slots cut into the drawer like the drawing shows.

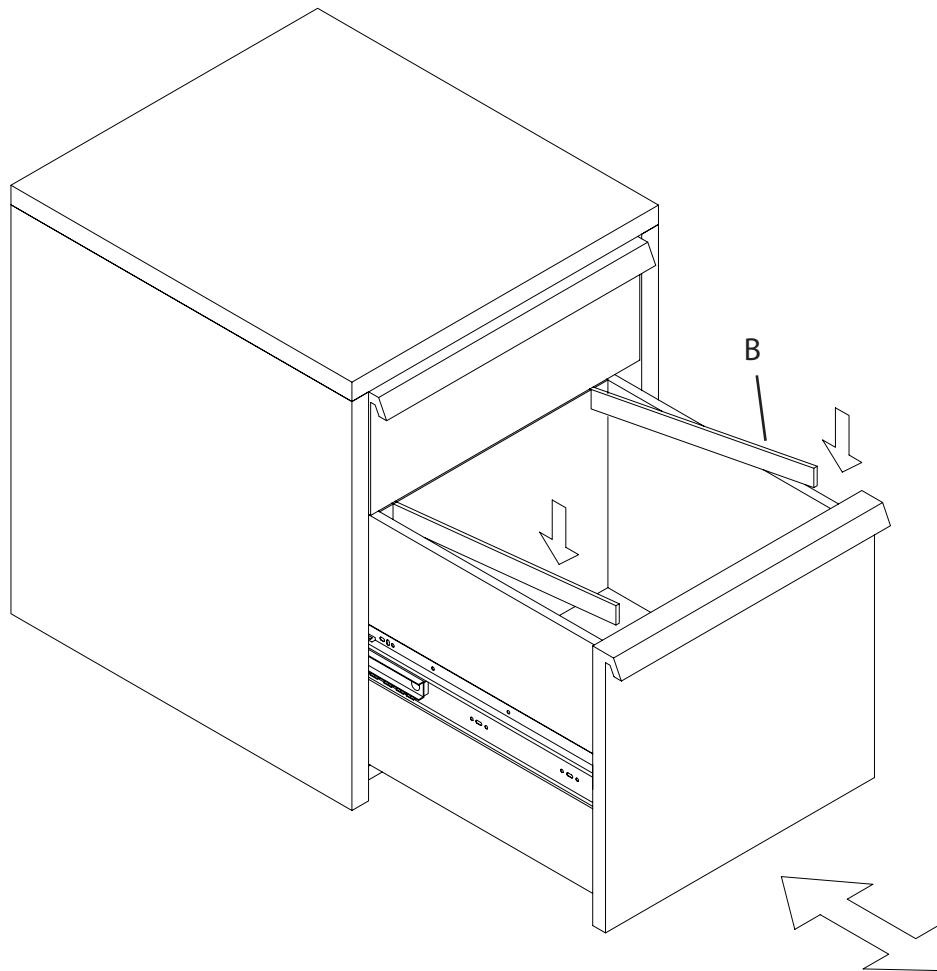

#### CARE INSTRUCTIONS

Hardware may loosen overtime. Periodically check that all connections are tight.

Wipe with a soft, dry cloth. To protect finish, avoid the use of chemicals and household cleaners.