

Thank you for purchasing this fine window treatment proudly constructed by us. Your blind has been custom-made to your personal specifications with the highest standards of quality and craftsmanship. We have confidence that it will provide you with many years of beauty and easy maintenance. Enjoy!

Follow the easy step-by-step instructions to install your blind. Should you need additional support, please feel free to call our Customer Service Center at 1-800-221-6352 or email us at windowfashions@springswindowfashions.com. We will be glad to help you.

Again, we appreciate that you have chosen us to enhance the design and look of your home.

Gracias por comprar este fino producto de ventana que hemos fabricado con orgullo. Su persiana ha sido fabricada de acuerdo a las especificaciones personales del cliente con los más altos estándares de artesanía y de calidad. Nosotros tenemos la confianza que nuestro producto le brindará muchos años de belleza y fácil mantenimiento. Le deseamos que la disfrute.

Siga las instrucciones "paso a paso" para instalar su persiana. Si necesitara soporte adicional haga el favor de llamar a nuestro Centro de Servicio al Cliente al teléfono 1-800-221-6352 o envíenos un correo electrónico a windowfashions@springswindowfashions.com. Estaremos encantados de ayudarle.

Nuevamente le agradecemos que nos haya escogido para mejorar el diseño y la apariencia de su hogar.

Merci d'avoir acheter ce superbe traitement pour fenêtre que nous sommes fiers d'avoir exécuté pour vous. Votre store a été fait sur mesure selon votre propre cahier des charges dans un souci d'excellence et de la plus haute technicité. Nous ne doutons pas qu'il vous offrira des années de beauté et d'entretien facile. Profitez-en bien!

Pour installer votre store, veuillez suivre les instructions détaillées. Si vous avez des questions, n'hésitez pas à prendre contact avec notre Centre de service après-vente en téléphonant au 1-800-221-6352 ou par courrier électronique au: windowfashions@springswindowfashions.com. Nous vous aiderons avec plaisir.

Encore une fois, nous vous remercions de nous avoir choisi pour améliorer et embellir votre intérieur.



HOW TO INSTALL CÓMO INSTALAR COMMENT INSTALLER

Outside-mount wood and faux wood blinds
Las persianas de madera y de imitación madera con montaje exterior
En pose extérieure des stores en bois et en imitation bois

1

Everything needed to install your blind

Todo lo necesario para instalar la persiana

Tout ce qu'il faut pour la pose du store

Optional • Opcional • Optionnel

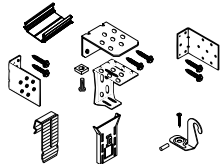

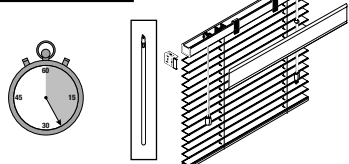

Tools needed
Herramientas necesarias
Outilsage nécessaire

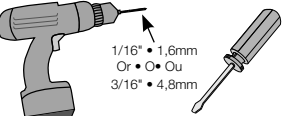

1/16" • 1,6mm
Ø • Ø • Øu
3/16" • 4,8mm

<p>Wood blinds with valances up to 2 1/4" tall:</p> <table border="1" style="width: 100%; border-collapse: collapse;"> <thead> <tr> <th>Valance Widths:</th> <th>Valance Clips:</th> </tr> </thead> <tbody> <tr><td>up to 36" use</td><td>2 clips</td></tr> <tr><td>up to 62" use</td><td>3 clips</td></tr> <tr><td>up to 88" use</td><td>4 clips</td></tr> <tr><td>up to 114" use</td><td>5 clips</td></tr> <tr><td>up to 120" use</td><td>6 clips</td></tr> <tr><td>over 120" use</td><td>7 clips</td></tr> </tbody> </table> <p>Wood blinds with valances taller than 2 1/4": Composite & faux wood blinds</p> <table border="1" style="width: 100%; border-collapse: collapse;"> <thead> <tr> <th>Valance widths:</th> <th>Valance clips:</th> </tr> </thead> <tbody> <tr><td>up to 22" use</td><td>2 clips</td></tr> <tr><td>up to 36" use</td><td>3 clips</td></tr> <tr><td>up to 50" use</td><td>4 clips</td></tr> <tr><td>up to 64" use</td><td>5 clips</td></tr> <tr><td>up to 78" use</td><td>6 clips</td></tr> <tr><td>up to 92" use</td><td>7 clips</td></tr> <tr><td>up to 106" use</td><td>8 clips</td></tr> <tr><td>up to 120" use</td><td>9 clips</td></tr> <tr><td>over 120" use</td><td>10 clips</td></tr> </tbody> </table> <p>All blinds</p> <table border="1" style="width: 100%; border-collapse: collapse;"> <thead> <tr> <th>Headrail widths:</th> <th>Center support brackets:</th> </tr> </thead> <tbody> <tr><td>up to 48" use</td><td>0</td></tr> <tr><td>up to 72" use</td><td>1</td></tr> <tr><td>up to 96" use</td><td>2</td></tr> <tr><td>up to 120" use</td><td>3</td></tr> <tr><td>up to 144" use</td><td>4</td></tr> </tbody> </table>	Valance Widths:	Valance Clips:	up to 36" use	2 clips	up to 62" use	3 clips	up to 88" use	4 clips	up to 114" use	5 clips	up to 120" use	6 clips	over 120" use	7 clips	Valance widths:	Valance clips:	up to 22" use	2 clips	up to 36" use	3 clips	up to 50" use	4 clips	up to 64" use	5 clips	up to 78" use	6 clips	up to 92" use	7 clips	up to 106" use	8 clips	up to 120" use	9 clips	over 120" use	10 clips	Headrail widths:	Center support brackets:	up to 48" use	0	up to 72" use	1	up to 96" use	2	up to 120" use	3	up to 144" use	4	<p>Persianas de madera con cenefas hasta 6,35 cm de alto:</p> <table border="1" style="width: 100%; border-collapse: collapse;"> <thead> <tr> <th>Anchos de Cenefa:</th> <th>Sujetadores de Cenefa:</th> </tr> </thead> <tbody> <tr><td>hasta 91,4 cm</td><td>uso 2 sujetadores</td></tr> <tr><td>hasta 157,5 cm</td><td>uso 3 sujetadores</td></tr> <tr><td>hasta 223,5 cm</td><td>uso 4 sujetadores</td></tr> <tr><td>hasta 289,6 cm</td><td>uso 5 sujetadores</td></tr> <tr><td>hasta 304,8 cm</td><td>uso 6 sujetadores</td></tr> <tr><td>mas de 304,8 cm</td><td>uso 7 sujetadores</td></tr> </tbody> </table> <p>Persianas de madera con cenefas más altas que 6,35 cm: Persianas de imitación madera</p> <table border="1" style="width: 100%; border-collapse: collapse;"> <thead> <tr> <th>Anchos de cenefa:</th> <th>Sujetadores de cenefa:</th> </tr> </thead> <tbody> <tr><td>hasta 55,9 cm</td><td>uso 2 sujetadores</td></tr> <tr><td>hasta 91,4 cm</td><td>uso 3 sujetadores</td></tr> <tr><td>hasta 127 cm</td><td>uso 4 sujetadores</td></tr> <tr><td>hasta 162,6 cm</td><td>uso 5 sujetadores</td></tr> <tr><td>hasta 198,1 cm</td><td>uso 6 sujetadores</td></tr> <tr><td>hasta 233,7 cm</td><td>uso 7 sujetadores</td></tr> <tr><td>hasta 269,2 cm</td><td>uso 8 sujetadores</td></tr> <tr><td>hasta 304,8 cm</td><td>uso 9 sujetadores</td></tr> <tr><td>mas de 304,8 cm</td><td>uso 10 sujetadores</td></tr> </tbody> </table> <p>Todas las persianas</p> <table border="1" style="width: 100%; border-collapse: collapse;"> <thead> <tr> <th>Anchos de cabezales:</th> <th>Soportes de sostén central:</th> </tr> </thead> <tbody> <tr><td>hasta 121,9 cm</td><td>uso 0</td></tr> <tr><td>hasta 182,9 cm</td><td>uso 1</td></tr> <tr><td>hasta 243,8 cm</td><td>uso 2</td></tr> <tr><td>hasta 304,8 cm</td><td>uso 3</td></tr> <tr><td>hasta 365,8 cm</td><td>uso 4</td></tr> </tbody> </table>	Anchos de Cenefa:	Sujetadores de Cenefa:	hasta 91,4 cm	uso 2 sujetadores	hasta 157,5 cm	uso 3 sujetadores	hasta 223,5 cm	uso 4 sujetadores	hasta 289,6 cm	uso 5 sujetadores	hasta 304,8 cm	uso 6 sujetadores	mas de 304,8 cm	uso 7 sujetadores	Anchos de cenefa:	Sujetadores de cenefa:	hasta 55,9 cm	uso 2 sujetadores	hasta 91,4 cm	uso 3 sujetadores	hasta 127 cm	uso 4 sujetadores	hasta 162,6 cm	uso 5 sujetadores	hasta 198,1 cm	uso 6 sujetadores	hasta 233,7 cm	uso 7 sujetadores	hasta 269,2 cm	uso 8 sujetadores	hasta 304,8 cm	uso 9 sujetadores	mas de 304,8 cm	uso 10 sujetadores	Anchos de cabezales:	Soportes de sostén central:	hasta 121,9 cm	uso 0	hasta 182,9 cm	uso 1	hasta 243,8 cm	uso 2	hasta 304,8 cm	uso 3	hasta 365,8 cm	uso 4	<p>Stores en bois avec cantonnières jusqu'à 6,35 cm de hauteur:</p> <table border="1" style="width: 100%; border-collapse: collapse;"> <thead> <tr> <th>Largeurs des cantonnières:</th> <th>Agrafes de cantonnière:</th> </tr> </thead> <tbody> <tr><td>Jusqu'à 91,4 cm</td><td>utiliser . . . 2 agrafes</td></tr> <tr><td>Jusqu'à 157,5 cm</td><td>utiliser . . . 3 agrafes</td></tr> <tr><td>Jusqu'à 223,5 cm</td><td>utiliser . . . 4 agrafes</td></tr> <tr><td>Jusqu'à 289,6 cm</td><td>utiliser . . . 5 agrafes</td></tr> <tr><td>Jusqu'à 304,8 cm</td><td>utiliser . . . 6 agrafes</td></tr> <tr><td>Supérieure à 304,8cm</td><td>utiliser . . . 7 agrafes</td></tr> </tbody> </table> <p>Stores en bois avec cantonnières d'une hauteur supérieure à 6,35 cm: Stores en imitation bois et composite</p> <table border="1" style="width: 100%; border-collapse: collapse;"> <thead> <tr> <th>Largeurs des cantonnières:</th> <th>Agrafes de cantonnière:</th> </tr> </thead> <tbody> <tr><td>Jusqu'à 55,9 cm</td><td>utiliser . . . 2 agrafes</td></tr> <tr><td>Jusqu'à 91,4 cm</td><td>utiliser . . . 3 agrafes</td></tr> <tr><td>Jusqu'à 127 cm</td><td>utiliser . . . 4 agrafes</td></tr> <tr><td>Jusqu'à 162,6 cm</td><td>utiliser . . . 5 agrafes</td></tr> <tr><td>Jusqu'à 198,1 cm</td><td>utiliser . . . 6 agrafes</td></tr> <tr><td>Jusqu'à 233,7 cm</td><td>utiliser . . . 7 agrafes</td></tr> <tr><td>Jusqu'à 269,2 cm</td><td>utiliser . . . 8 agrafes</td></tr> <tr><td>Jusqu'à 304,8 cm</td><td>utiliser . . . 9 agrafes</td></tr> <tr><td>Supérieure à 304,8 cm</td><td>utiliser . . . 10 agrafes</td></tr> </tbody> </table> <p>Tous les stores</p> <table border="1" style="width: 100%; border-collapse: collapse;"> <thead> <tr> <th>Largeurs des boîtiers:</th> <th>Supports de soutien central:</th> </tr> </thead> <tbody> <tr><td>Jusqu'à 121,9 cm</td><td>utiliser . . . 0</td></tr> <tr><td>Jusqu'à 182,9 cm</td><td>utiliser . . . 1</td></tr> <tr><td>Jusqu'à 243,8 cm</td><td>utiliser . . . 2</td></tr> <tr><td>Jusqu'à 304,8 cm</td><td>utiliser . . . 3</td></tr> <tr><td>Jusqu'à 365,8 cm</td><td>utiliser . . . 4</td></tr> </tbody> </table>	Largeurs des cantonnières:	Agrafes de cantonnière:	Jusqu'à 91,4 cm	utiliser . . . 2 agrafes	Jusqu'à 157,5 cm	utiliser . . . 3 agrafes	Jusqu'à 223,5 cm	utiliser . . . 4 agrafes	Jusqu'à 289,6 cm	utiliser . . . 5 agrafes	Jusqu'à 304,8 cm	utiliser . . . 6 agrafes	Supérieure à 304,8cm	utiliser . . . 7 agrafes	Largeurs des cantonnières:	Agrafes de cantonnière:	Jusqu'à 55,9 cm	utiliser . . . 2 agrafes	Jusqu'à 91,4 cm	utiliser . . . 3 agrafes	Jusqu'à 127 cm	utiliser . . . 4 agrafes	Jusqu'à 162,6 cm	utiliser . . . 5 agrafes	Jusqu'à 198,1 cm	utiliser . . . 6 agrafes	Jusqu'à 233,7 cm	utiliser . . . 7 agrafes	Jusqu'à 269,2 cm	utiliser . . . 8 agrafes	Jusqu'à 304,8 cm	utiliser . . . 9 agrafes	Supérieure à 304,8 cm	utiliser . . . 10 agrafes	Largeurs des boîtiers:	Supports de soutien central:	Jusqu'à 121,9 cm	utiliser . . . 0	Jusqu'à 182,9 cm	utiliser . . . 1	Jusqu'à 243,8 cm	utiliser . . . 2	Jusqu'à 304,8 cm	utiliser . . . 3	Jusqu'à 365,8 cm	utiliser . . . 4
Valance Widths:	Valance Clips:																																																																																																																																											
up to 36" use	2 clips																																																																																																																																											
up to 62" use	3 clips																																																																																																																																											
up to 88" use	4 clips																																																																																																																																											
up to 114" use	5 clips																																																																																																																																											
up to 120" use	6 clips																																																																																																																																											
over 120" use	7 clips																																																																																																																																											
Valance widths:	Valance clips:																																																																																																																																											
up to 22" use	2 clips																																																																																																																																											
up to 36" use	3 clips																																																																																																																																											
up to 50" use	4 clips																																																																																																																																											
up to 64" use	5 clips																																																																																																																																											
up to 78" use	6 clips																																																																																																																																											
up to 92" use	7 clips																																																																																																																																											
up to 106" use	8 clips																																																																																																																																											
up to 120" use	9 clips																																																																																																																																											
over 120" use	10 clips																																																																																																																																											
Headrail widths:	Center support brackets:																																																																																																																																											
up to 48" use	0																																																																																																																																											
up to 72" use	1																																																																																																																																											
up to 96" use	2																																																																																																																																											
up to 120" use	3																																																																																																																																											
up to 144" use	4																																																																																																																																											
Anchos de Cenefa:	Sujetadores de Cenefa:																																																																																																																																											
hasta 91,4 cm	uso 2 sujetadores																																																																																																																																											
hasta 157,5 cm	uso 3 sujetadores																																																																																																																																											
hasta 223,5 cm	uso 4 sujetadores																																																																																																																																											
hasta 289,6 cm	uso 5 sujetadores																																																																																																																																											
hasta 304,8 cm	uso 6 sujetadores																																																																																																																																											
mas de 304,8 cm	uso 7 sujetadores																																																																																																																																											
Anchos de cenefa:	Sujetadores de cenefa:																																																																																																																																											
hasta 55,9 cm	uso 2 sujetadores																																																																																																																																											
hasta 91,4 cm	uso 3 sujetadores																																																																																																																																											
hasta 127 cm	uso 4 sujetadores																																																																																																																																											
hasta 162,6 cm	uso 5 sujetadores																																																																																																																																											
hasta 198,1 cm	uso 6 sujetadores																																																																																																																																											
hasta 233,7 cm	uso 7 sujetadores																																																																																																																																											
hasta 269,2 cm	uso 8 sujetadores																																																																																																																																											
hasta 304,8 cm	uso 9 sujetadores																																																																																																																																											
mas de 304,8 cm	uso 10 sujetadores																																																																																																																																											
Anchos de cabezales:	Soportes de sostén central:																																																																																																																																											
hasta 121,9 cm	uso 0																																																																																																																																											
hasta 182,9 cm	uso 1																																																																																																																																											
hasta 243,8 cm	uso 2																																																																																																																																											
hasta 304,8 cm	uso 3																																																																																																																																											
hasta 365,8 cm	uso 4																																																																																																																																											
Largeurs des cantonnières:	Agrafes de cantonnière:																																																																																																																																											
Jusqu'à 91,4 cm	utiliser . . . 2 agrafes																																																																																																																																											
Jusqu'à 157,5 cm	utiliser . . . 3 agrafes																																																																																																																																											
Jusqu'à 223,5 cm	utiliser . . . 4 agrafes																																																																																																																																											
Jusqu'à 289,6 cm	utiliser . . . 5 agrafes																																																																																																																																											
Jusqu'à 304,8 cm	utiliser . . . 6 agrafes																																																																																																																																											
Supérieure à 304,8cm	utiliser . . . 7 agrafes																																																																																																																																											
Largeurs des cantonnières:	Agrafes de cantonnière:																																																																																																																																											
Jusqu'à 55,9 cm	utiliser . . . 2 agrafes																																																																																																																																											
Jusqu'à 91,4 cm	utiliser . . . 3 agrafes																																																																																																																																											
Jusqu'à 127 cm	utiliser . . . 4 agrafes																																																																																																																																											
Jusqu'à 162,6 cm	utiliser . . . 5 agrafes																																																																																																																																											
Jusqu'à 198,1 cm	utiliser . . . 6 agrafes																																																																																																																																											
Jusqu'à 233,7 cm	utiliser . . . 7 agrafes																																																																																																																																											
Jusqu'à 269,2 cm	utiliser . . . 8 agrafes																																																																																																																																											
Jusqu'à 304,8 cm	utiliser . . . 9 agrafes																																																																																																																																											
Supérieure à 304,8 cm	utiliser . . . 10 agrafes																																																																																																																																											
Largeurs des boîtiers:	Supports de soutien central:																																																																																																																																											
Jusqu'à 121,9 cm	utiliser . . . 0																																																																																																																																											
Jusqu'à 182,9 cm	utiliser . . . 1																																																																																																																																											
Jusqu'à 243,8 cm	utiliser . . . 2																																																																																																																																											
Jusqu'à 304,8 cm	utiliser . . . 3																																																																																																																																											
Jusqu'à 365,8 cm	utiliser . . . 4																																																																																																																																											

2

Mark location of blind

Marque la ubicación de la persiana

Marquez l'emplacement du store

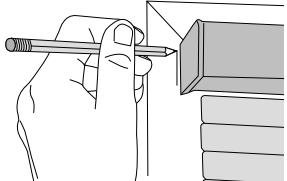



3

Mark bracket location

Marque la ubicación de la ménsula

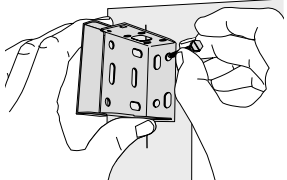
Marquez la position du support



SPRINGS WINDOW FASHIONS
the Best Experience Company 

78192-06 (5/12)

3

Optional center support(s)/projection brackets
Opcional sosten central/soportes de extensión
Facultatif supports du centre/supports de projection

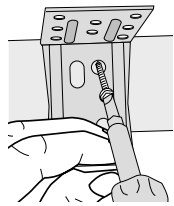

Position the center support(s) in line with the mounting brackets so it will not interfere with the ladder tapes. Space evenly and keep out of the way of other working parts.

Ponga el sosten central en línea con las ménsulas de instalación de modo que no interfieran con las cintas de escalerillas. Ponga a espacios iguales y alejado de las piezas operacionales.

Placer les supports du centre dans le prolongement des supports de montage de manière à ne pas gêner l'échelle de support des lamelles. Placez-les à intervalles réguliers et hors de contact avec toute pièce mobile.

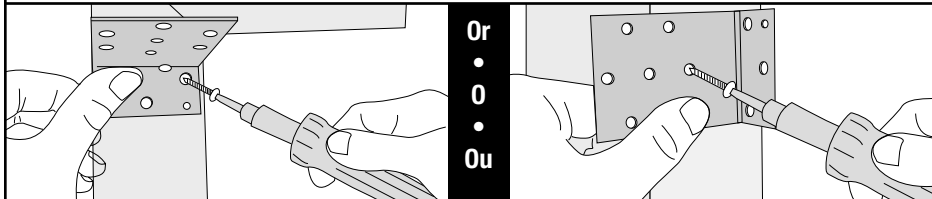

Or
•
O
•
Ou

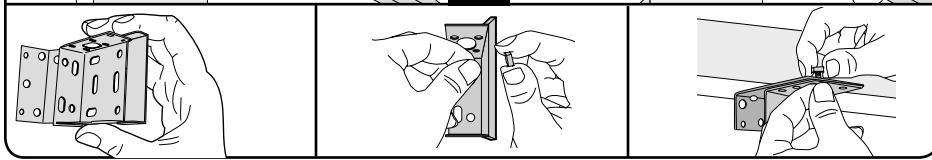
**4**

Drill holes
Perfore agujeros
Percez des trous

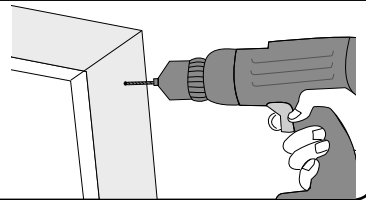
**4**

Optional bracket spacers
Opcional espaciadores de soportes
Optionnel écarteurs de supports

Provided with 2 1/4" and 2 1/2" blinds only
 Se suministra solamente con persianas de 6 cm y de 6,35 cm
 Fourni uniquement avec les stores de 6 cm et de 6,35 cm

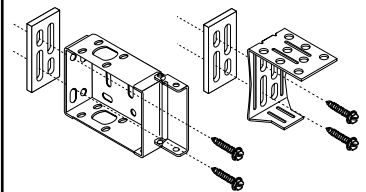

2 1/4" & 2 1/2" Blinds
 Persianas de 6 cm y de 6,35 cm
 Stores de 6 cm et de 6,35 cm

**5**

Screw in brackets
Atornille las ménsulas
Vissez les supports

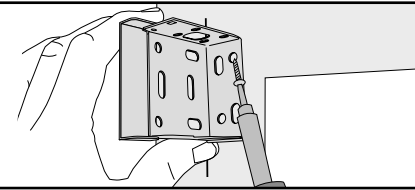
**6**

Attach valance clips
Ponga el sujetador de cenefa
Fixez l'attache de cantonnière

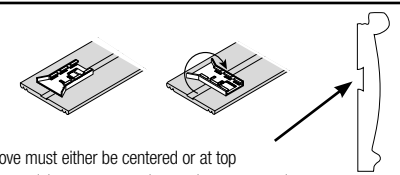
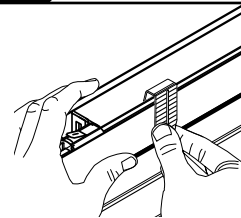

Groove must either be centered or at top
 El surco debe estar centrado o en la parte superior
 La rainure doit être centrée ou en haut

Space clips evenly across width. Clips must not interfere with ladder tapes.

Distribuya los sujetadores a distancias iguales por todo lo ancho. Los sujetadores no deben interferir con las cintas de las esterillas

Placer les fixations à espace régulier sur toute la largeur. Les fixations ne doivent pas gêner les rubans à jalousie.

7

Mount blind in brackets; close door
Instale la persiana en las ménsulas; cierre la puerta
Fixez le store dans les supports; fermez la porte

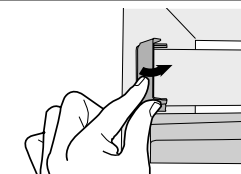
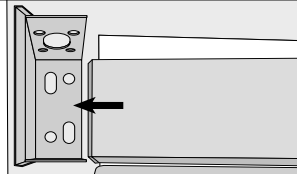

7

Optional valance with returns and spliced valance Cenefa opcional con retornos y cenefas empalmadas Cantonnière à entures et cantonnières avec retours en option

Valance returns • Retornos de cenefa • Retour de cantonnière

Spliced valance • Cenefa empalmada • Cantonnière à enture

Some returns are pre-assembled.
Algunos retornos son pre-ensamblados
Certains retours sont tout montés

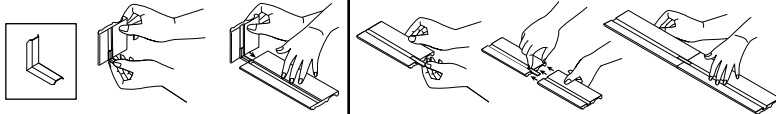

8

Attach valance Ponga la cenefa Fixez la cantonnière

Remove tab only if visible below valance
Remueva la lengüeta solamente si es visible por abajo de la cenefa
N'enlever la languette que si elle est visible au-dessous de la cantonnière

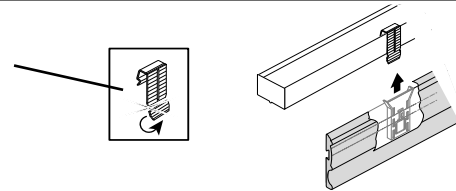

8

Optional hold-down brackets Opcional soportes sostenedores Optionnel supports de retenue

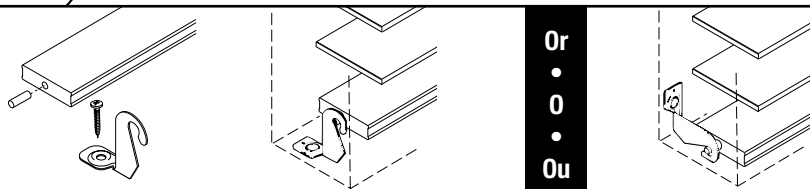

Or
•
O
•
Ou



Additional instructions: See page 3
Instrucciones adicionales – Consulte la página 3
Instructions supplémentaires – Reportez-vous à la page 3

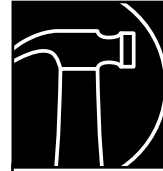

HOW TO INSTALL CÓMO INSTALAR COMMENT INSTALLER

Ceiling-mount wood and faux wood blinds

Las persianas de madera y de imitación de madera con montaje de cielo

Au plafond des stores en bois et en imitation bois

1

Everything needed to install your blind Todo lo necesario para instalar la persiana Tout ce qu'il faut pour la pose du store

Optional • Opcional • Optionnel

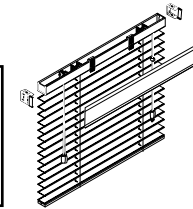
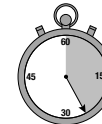
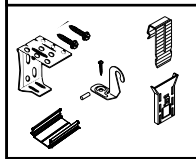

Tools needed
Herramientas necesarias
Outilsage nécessaire

1/16" • 1,6mm
Or • O • Ou
3/16" • 4,8mm

Wood blinds with valances up to 2 1/2" tall:

Valance widths:	Valance clips:
up to 36" use	2 clips
up to 62" use	3 clips
up to 88" use	4 clips
up to 114" use	5 clips
up to 120" use	6 clips
over 120" use	7 clips

Wood blinds with valances taller than 2 1/2": Composite & faux wood blinds

Valance widths:	Valance clips:
up to 22" use	2 clips
up to 36" use	3 clips
up to 50" use	4 clips
up to 64" use	5 clips
up to 78" use	6 clips
up to 92" use	7 clips
up to 106" use	8 clips
up to 120" use	9 clips
over 120" use	10 clips

All blinds

Headrail widths:	Center support brackets:
up to 48" use	0
up to 72" use	1
up to 96" use	2
up to 120" use	3
up to 144" use	4

Persianas de madera con cenefas hasta 6,35 cm de alto:

Anchos de cenefa:	Sujetadores de cenefa:
hasta 91,4 cm	uso... 2 sujetadores
hasta 157,5 cm	uso... 3 sujetadores
hasta 223,5 cm	uso... 4 sujetadores
hasta 289,6 cm	uso... 5 sujetadores
hasta 304,8 cm	uso... 6 sujetadores
mas de 304,8 cm	uso... 7 sujetadores

Persianas de madera con cenefas más altas que 6,35 cm: Persianas de imitación madera

Anchos de cenefa:	Sujetadores de cenefa:
hasta 55,9 cm	uso... 2 sujetadores
hasta 91,4 cm	uso... 3 sujetadores
hasta 127 cm	uso... 4 sujetadores
hasta 162,6 cm	uso... 5 sujetadores
hasta 198,1 cm	uso... 6 sujetadores
hasta 233,7 cm	uso... 7 sujetadores
hasta 269,2 cm	uso... 8 sujetadores
hasta 304,8 cm	uso... 9 sujetadores
mas de 304,8 cm	uso... 10 sujetadores

Todas las persianas

Anchos de cabezales:	Soportes de sostén central:
hasta 121,9 cm	uso... 0
hasta 182,9 cm	uso... 1
hasta 243,8 cm	uso... 2
hasta 304,8 cm	uso... 3
hasta 365,8 cm	uso... 4

Stores en bois avec cantonnières jusqu'à 6,35 cm de hauteur:

Largeurs des cantonnières :	Agrafes de cantonnière:
Jusqu'à 91,4 cm	utiliser... 2 agrafes
Jusqu'à 157,5 cm	utiliser... 3 agrafes
Jusqu'à 223,5 cm	utiliser... 4 agrafes
Jusqu'à 289,6 cm	utiliser... 5 agrafes
Jusqu'à 304,8 cm	utiliser... 6 agrafes
Supérieure à 304,8cm	utiliser... 7 agrafes

Stores en bois avec cantonnières d'une hauteur supérieure à 6,35 cm: Stores en imitation bois et composite

Largeurs des cantonnières :	Agrafes de cantonnière:
Jusqu'à 55,9 cm	utiliser... 2 agrafes
Jusqu'à 91,4 cm	utiliser... 3 agrafes
Jusqu'à 127 cm	utiliser... 4 agrafes
Jusqu'à 162,6 cm	utiliser... 5 agrafes
Jusqu'à 198,1 cm	utiliser... 6 agrafes
Jusqu'à 233,7 cm	utiliser... 7 agrafes
Jusqu'à 269,2 cm	utiliser... 8 agrafes
Jusqu'à 304,8 cm	utiliser... 9 agrafes
Supérieure à 304,8 cm	utiliser... 10 agrafes

Tous les stores

Largeurs des boîtiers :	Supports de soutien central:
Jusqu'à 121,9 cm	utiliser... 0
Jusqu'à 182,9 cm	utiliser... 1
Jusqu'à 243,8 cm	utiliser... 2
Jusqu'à 304,8 cm	utiliser... 3
Jusqu'à 365,8 cm	utiliser... 4

2

Mark location of blind
Marque la ubicación de la persiana
Marquez l'emplacement du store

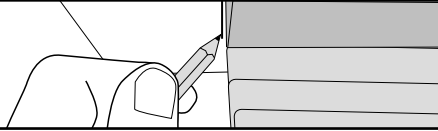
**3**

Mark bracket location
Marque la ubicación de la ménsula
Marquez la position du support

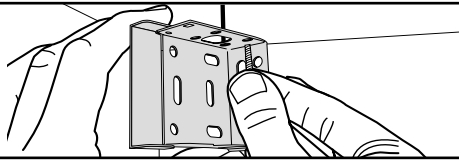
**3**

Optional center support(s)
Opcional sosten central
Facultatif supports du centre

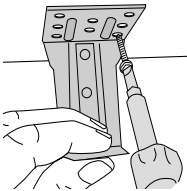

Position the center support(s) in line with the mounting brackets so it will not interfere with the ladder tapes. Space evenly and keep out of the way of other working parts.

Ponga el sosten central en línea con las ménsulas de instalación de modo que no interfieran con las cintas de escalerillas. Ponga a espacios iguales y alejado de las piezas operacionales.

Placer les supports du centre dans le prolongement des supports de montage de manière à ne pas gêner l'échelle de support des lamelles. Placez-les à intervalles réguliers et hors de contact avec toute pièce mobile.

4

Drill holes
Perfore agujeros
Percez des trous

**5**

Screw in brackets
Atornille las ménsulas
Vissez les supports

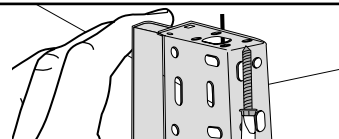
**6**

Attach valance clips
Ponga el sujetador de cenefa
Fixez l'attache de cantonnière

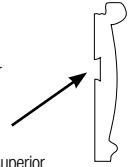
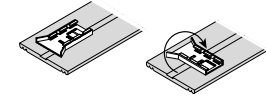
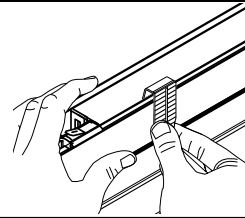

Groove must either be centered or at top
 El surco debe estar centrado o en la parte superior
 La rainure doit être centrée ou en haut

Space clips evenly across width. Clips must not interfere with ladder tapes.
 Separe los sujetadores a distancias iguales por todo lo ancho. Los sujetadores no deben interferir con las cintas de las esteras.
 Espacer de façon égale les agrafes sur la largeur. Les agrafes ne doivent pas gêner les rubans à jalousie.

7

Mount blind in brackets
Instale la persiana en las ménsulas
Fixez le store dans les supports

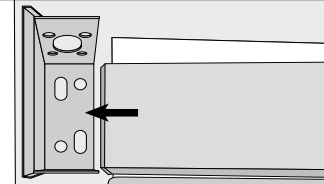
**8**

Close door on brackets
Cierre la puerta en las ménsulas
Fermez la porte des supports

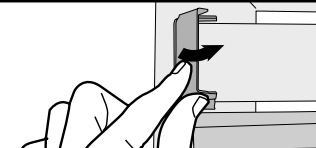

8

Optional valance with returns and spliced valance
Cenefa opcional con retornos y cenefas empalmadas
Cantonnière à entures et cantonnières avec retours en option

Valance returns • Retornos de cenefa • Retours de cantonnrière

Spliced valance • Cenefa empalmada • Cantonnrière à enture

Some returns are pre-assembled.
 Algunos retornos son pre-ensamblados
 Certains retours sont tout montés

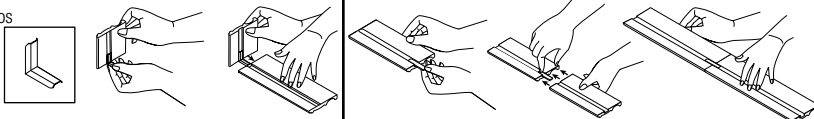

9

Attach valance
Ponga la cenefa
Fixez la cantonnrière

Remove tab only if visible below valance
 Remueva la lengüeta solamente si es visible por abajo de la cenefa
 N'enlever la languette que si elle est visible au-dessous de la cantonnrière

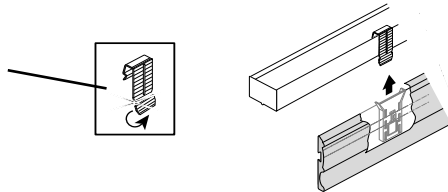

9

Optional hold-down brackets
Opcional soportes sostenedores
Optionnel supports de retenue

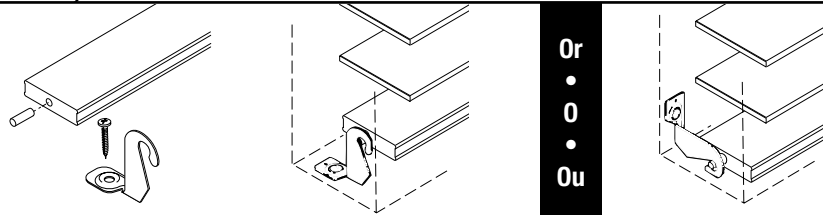

Or
 •
 O
 •
 Ou



Additional instructions
Instrucciones adicionales
Instructions supplémentaires

Attach tilt wand • Acoplamiento de la vara giratoria • Fixation de la baguette d'inclinaison

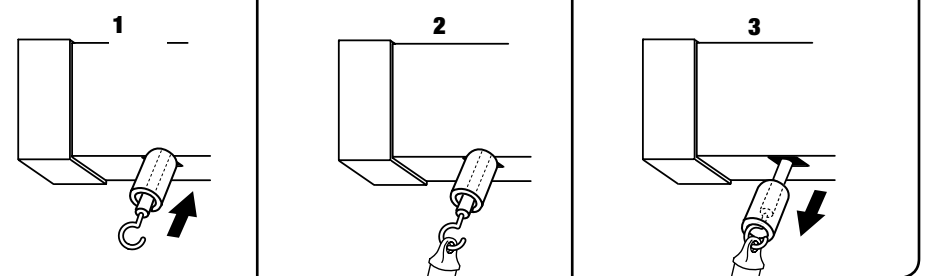

Cordless blind tilt wand attachment • Acoplamiento de la vara giratoria para persianas sin cordón
 • Store Sans fil attachement de baguette d'inclinaison

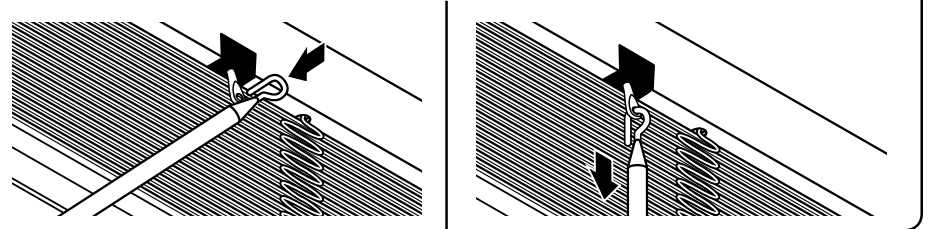

Additional instructions: See page 3
Instrucciones adicionales – Consulte la página 3
Instructions supplémentaires – Reportez-vous à la page 3

Raising and lowering a cordless blind • Cómo subir y bajar una persiana sin cordón
• Relever et abaisser un store sans cordon

Always raise and lower with blind open. To lower blind, simply pull down using the bottomrail. To raise the blind, simply guide the blind to the desired position by gently lifting the bottomrail. On inside-mount blinds, the blind may need to be pulled away from the window slightly in order to fully lower the blind.

Suba y baje la persiana siempre abierta. Para bajar la persiana, simplemente tire hacia abajo utilizando las riel inferior. Para subirla, simplemente guíe la persiana hacia la ubicación deseada levantando suavemente el riel inferior. En el caso de las persianas de montaje interno, es posible que deba alejar ligeramente la persiana de la ventana para bajarla completamente.

Relevez et abaissez toujours le store lorsqu'il est ouvert. Pour abaisser le store, tirez simplement vers le bas sur le rail inférieur. Pour relever le store, guidez simplement le store jusqu'à la position désirée en relevant doucement le rail inférieur. Sur les stores à montage intérieur, le store peut avoir besoin d'être tiré légèrement hors de la fenêtre afin d'abaisser complètement le store.

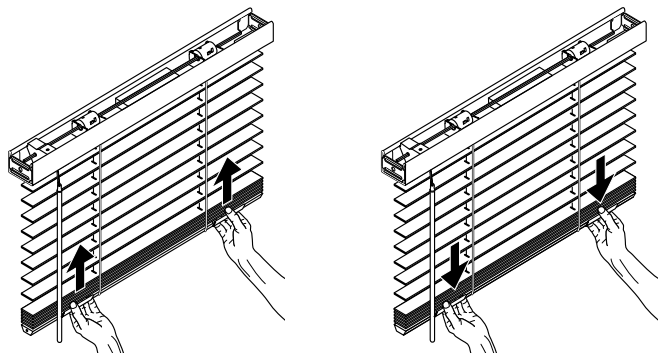

Wood blinds: Wipe with a soft cloth or lightly vacuum with a soft brush attachment.

All other blinds: Use warm water and mild, non-abrasive liquid soap.

Persianas de madera – Limpie con paño suave o aspire levemente con accesorio de cepillo suave.

Todas las otras persianas – Limpie con agua tibia y jabón líquido suave no raspante.

Stores en bois – Nettoyez avec un chiffon doux ou avec la brosse douce de votre aspirateur.

Tous les autres stores – utilisez de l'eau tiède et un savon doux liquide non abrasif.



Cordless blind trouble shooting • Solución de problemas para persianas sin cordón
• Dépannage pour les stores sans cordon

Blind not level when raised.

It is important to always lift and lower your blind in a level manner. If the blind is not lifted and lowered in a balanced manner, the cords may be taken up by the springs at different rates causing the blind to hang crooked. To correct this situation, lower and raise blind while level.

La persiana no está nivelada cuando está levantada.

Es importante subir y bajar la persiana siempre de manera nivelada. Si no se sube y baja la persiana de manera nivelada, es posible que los resortes hagan subir los cordones a diferentes velocidades lo que provocará que la persiana quede torcida. Para corregir esta situación, baje y suba la persiana nivelándola al mismo tiempo.

Le store n'est pas au niveau lorsqu'il est relevé.

Il est important de toujours relever et abaisser votre store de manière égale. Si le store n'est pas relevé ou abaissé de façon équilibrée, les cordons peuvent être pris par les ressorts à des rythmes différents et causer le désalignement du store. Pour corriger cette situation, abaissez et relevez le store lorsqu'il est au niveau.

Blind hangs crooked.

During shipping the ladder tapes may fall off the tape drums and cause the blind to hang crooked. To correct, rotate the slats all the way in one direction until the blind is in a closed position. Next, rotate the slats all the way in the opposite direction until the blind is in a closed position. The ladder tapes will be corrected and blind should hang even.

La persiana está torcida.

Durante el proceso de envío, es posible que las cintas de nivel se desprendan de los tambores y hagan que la persiana quede torcida. Para corregir este problema, gire las tablillas completamente en una dirección hasta que la persiana se encuentre en la posición cerrada. Luego, gire las tablillas completamente en dirección contraria hasta que la persiana se encuentre en la posición cerrada. Las cintas de nivel se corregirán y la persiana quedará colgada de manera uniforme.

Le store pend de travers.

Pendant l'expédition, les rubans d'échelle peuvent tomber des tambours à ruban et entraîner le désalignement du store. Pour corriger, pivotez les lattes complètement dans une direction jusqu'à ce que le store soit fermé. Ensuite, pivotez les lattes complètement dans la direction opposée jusqu'à ce que le store soit fermé. Les rubans d'échelle seront corrigés et le store devrait pendre correctement.