

# Z DESK

**Important Safety Instructions:**

- Please read all instructions carefully before assembling.
- For your safety, assembly by two or more adults is strongly recommended.
- Keep instructions for future use.
- Use only vendor supplied hardware to assemble. Using unauthorized hardware could jeopardize the structural integrity of the item.

**Pre-assembly:**



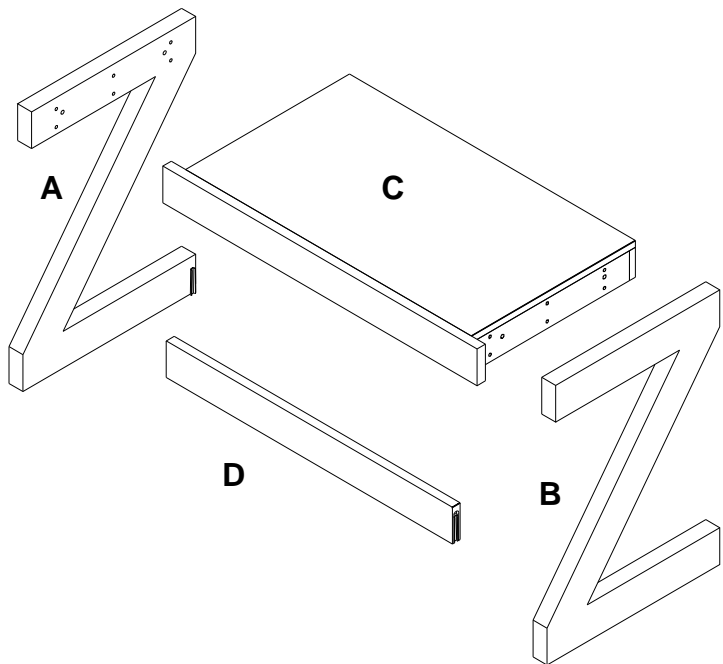

- Remove all parts and hardware from the box and lay out on a clear carpeted or scratch-free work surface, as this will avoid damaging parts during assembly. The shipping box provides an ideal work surface.
- Do not dispose of any packaging or contents of the shipping carton until assembly is completed to avoid accidentally discarding small parts or hardware.
- Use the parts and hardware lists below to identify and separate each of the pieces included.
- The illustrations provided allow for easier assembly when used in conjunction with the assembly instructions.
- The use of power tools to aid in assembly is not recommended. Power tools can damage hardware and split wood.

**Parts Included:**

- (A) Left Side 1x
- (B) Right Side 1x
- (C) Top Panel 1x
- (D) Bottom Rail 1x

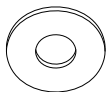

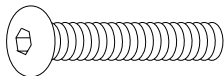
**Hardware Included:**

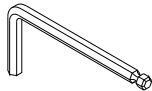
<p>(E) Flat Washer</p>  <p>Dia. 1/4"x16mm 12x</p>	<p>(F) Spring Washer</p>  <p>Dia. 1/4" 12x</p>	<p>(G) Bolt</p>  <p>Dia. 1/4"x1-1/2" 12x</p>
<p>(H) Wood Dowel</p>  <p>Dia. 10x30mm 4x</p>	<p>(I) Allen Key</p>  <p>4mm 1x</p>	

**Assembly Instruction Steps:**

1. Take the drawer out of Top Panel (C) as shown.

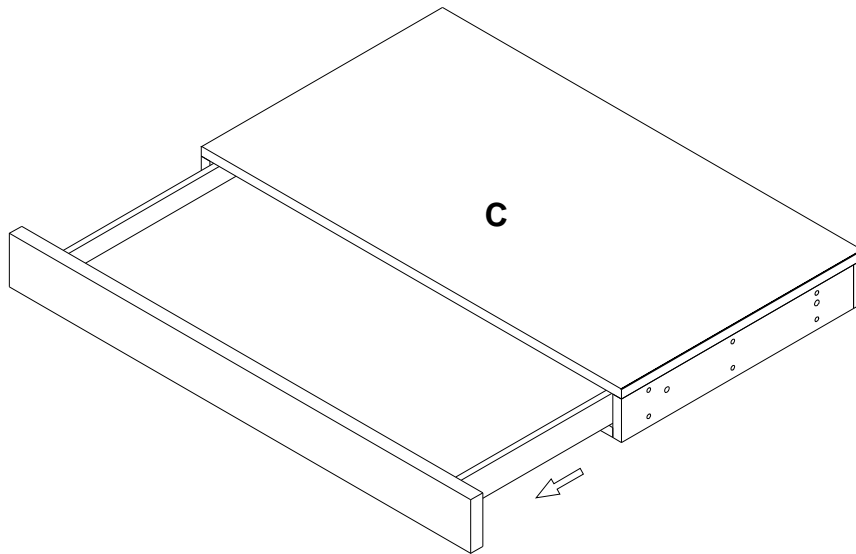

2. Carefully turn the Table Top (A) upside down on soft, scratch-free surface such as a carpet or rug. Insert the Wood Dowel (H) to the top as shown, and then attach Left Side (A) and Right Side (B) to Top Panel (A), insert Bolt (G) thru Spring Washer (F) and Flat Washer (E), securely tighten all bolts with Allen Key (I).

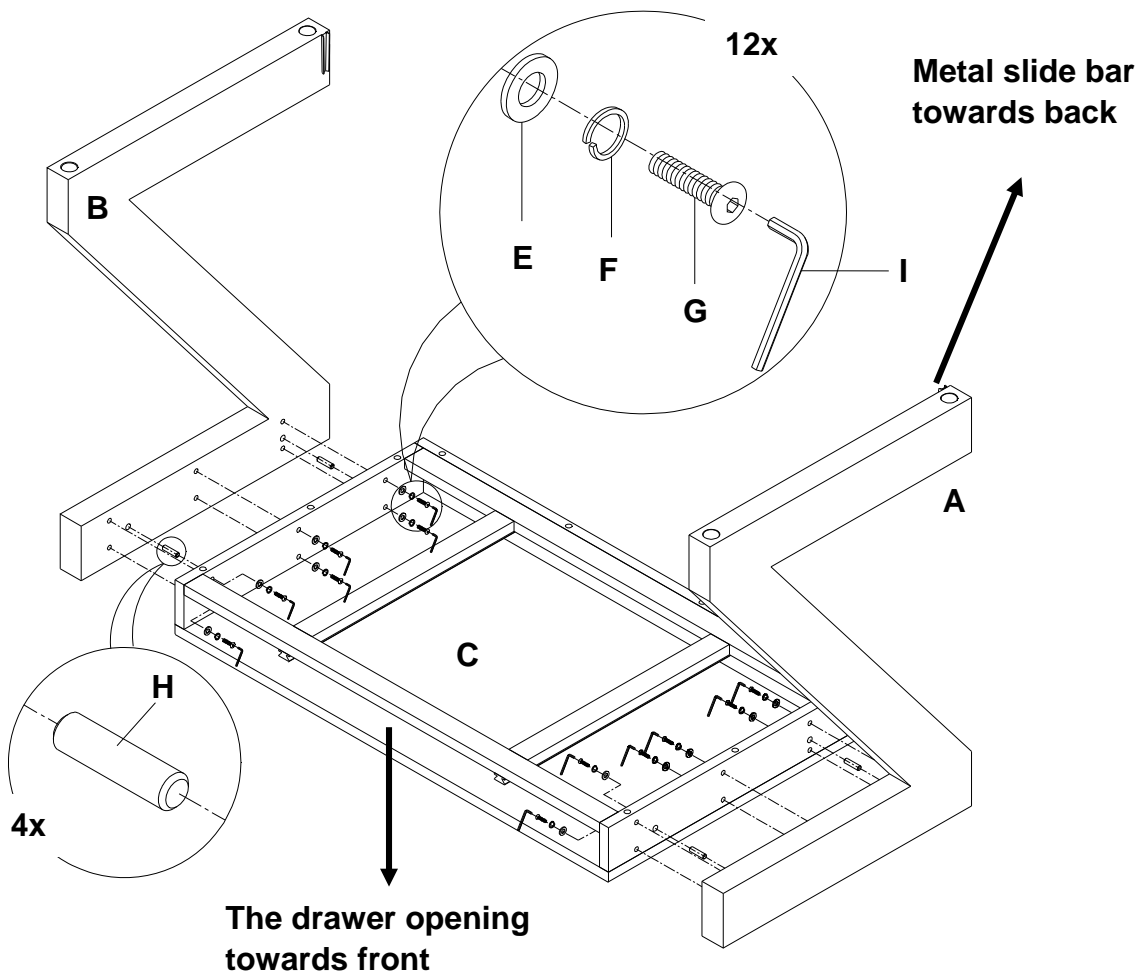

3. Carefully turn the table upright. Align the slider at Bottom Rail (D) with the slider on table side (A&B) as shown, insert the both end of Rail at the same time.

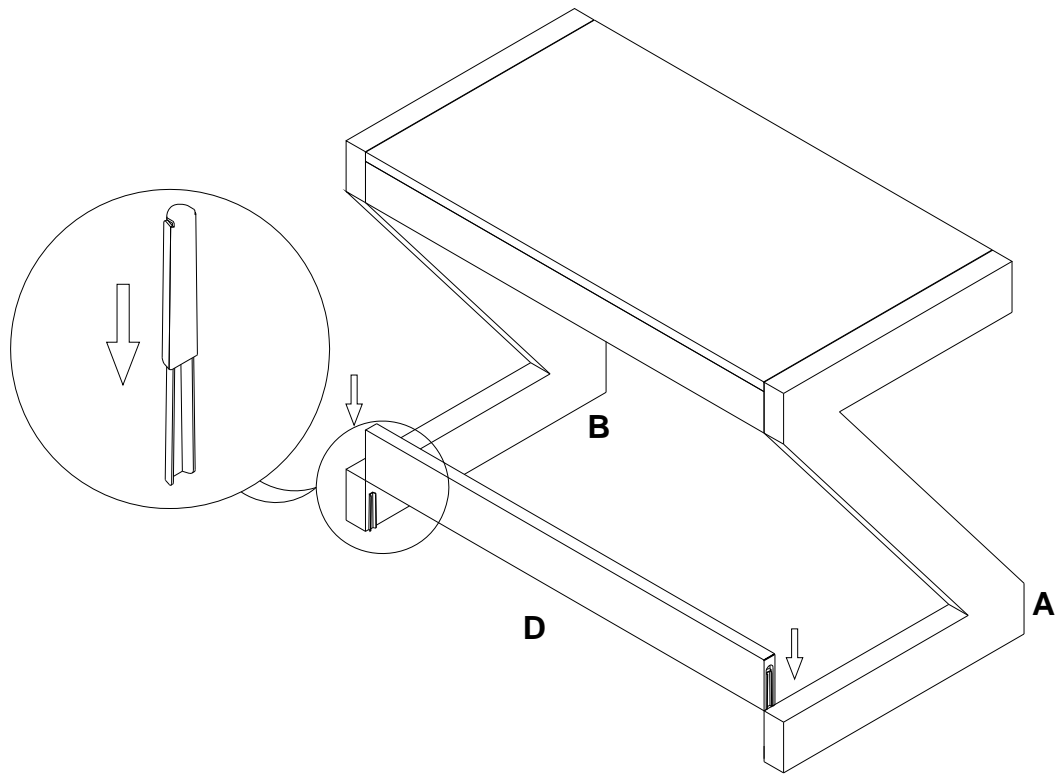

4. Insert drawer back to the top as the shown. Assembly is complete.

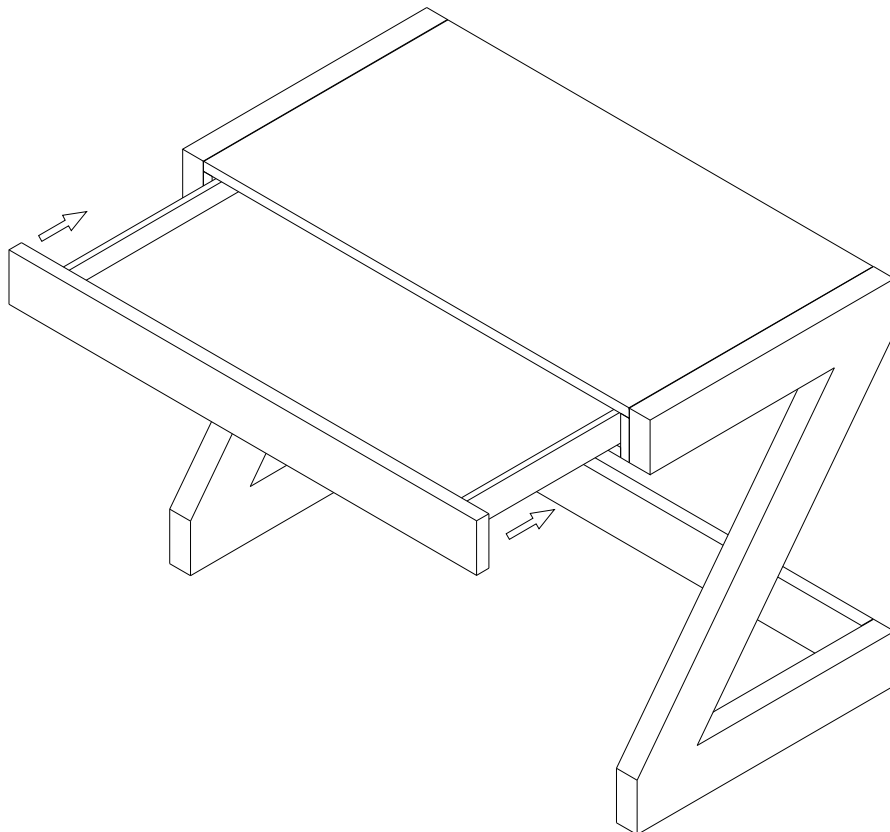

### Adjusting the levelers:

Due to an uneven floor, the furniture may not sit level due causing it to wobble. If the furniture wobbles, determine which corner does not touch the ground correctly. With two people follow these steps:

1. Carefully elevate the item slightly to provide access to the levelers attached to the bottom.
2. Turn the levelers until adequate contact will be made with the floor. Gently set down the piece and check stability.
3. Repeat steps until furniture sits firmly on the ground.

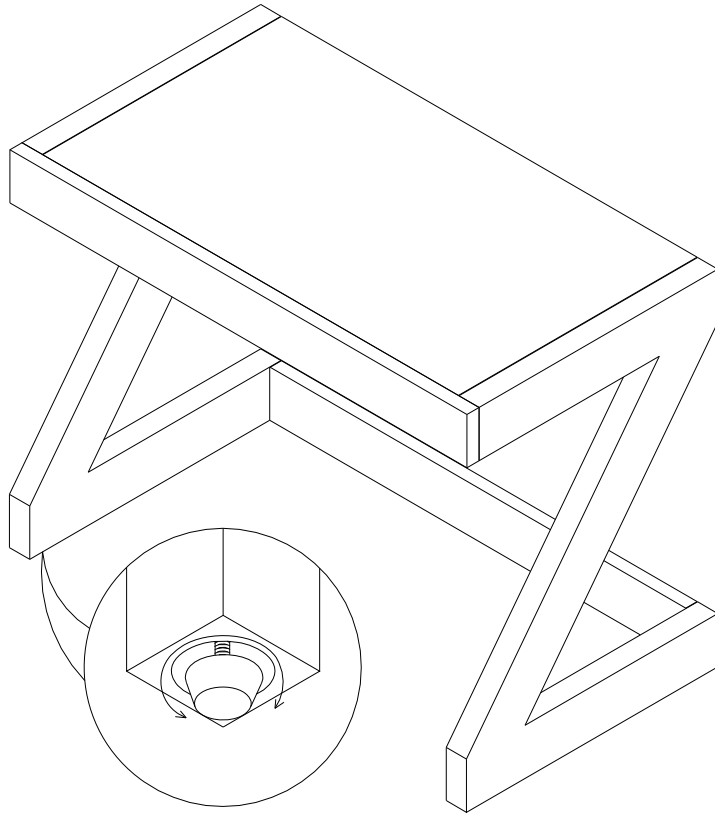

### Care Instructions:

- Dust often using a clean, soft, dry and lint-free cloth.
- Blot spills immediately and wipe with a clean, damp, cloth.
- We do not recommend the use of chemical cleansers, abrasives or furniture polish on our lacquered finish.
- Hardware may loosen over time. Periodically check to make sure all connections are tight.  
Re-tighten if necessary.

Thank you for your purchase  
Stores | catalog