

## **CUSTOMIZE IT DESK STORAGE PEDESTAL**

**Important Safety Instructions:**

- Please read all instructions carefully before assembling.
- For your safety, assembly by two or more adults is strongly recommended.
- Keep instructions for future use.
- Use only vendor supplied hardware to assemble. Using unauthorized hardware could jeopardize the structural integrity of the item.

**Pre-assembly:**



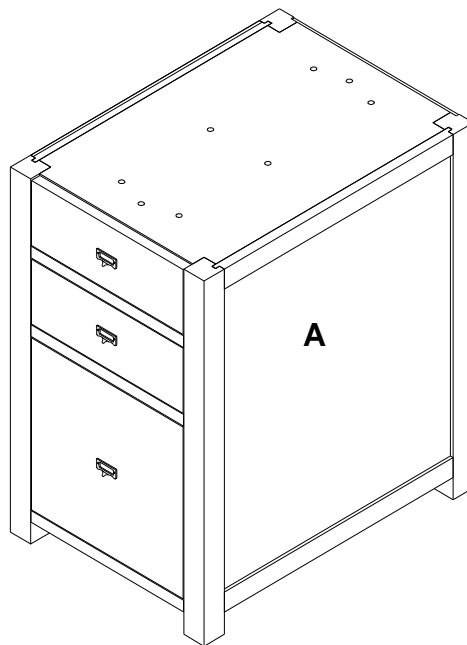

- Remove all parts and hardware from the box and lay out on a clear carpeted or scratch-free work surface, as this will avoid damaging parts during assembly. The shipping box provides an ideal work surface.
- Do not dispose of any packaging or contents of the shipping carton until assembly is completed to avoid accidentally discarding small parts or hardware.
- Use the parts and hardware lists below to identify and separate each of the pieces included.
- The illustrations provided allow for easier assembly when used in conjunction with the assembly instructions.
- The use of power tools to aid in assembly is not recommended. Power tools can damage hardware and split wood.

**Parts Included:**

(A) Cabinet 1x

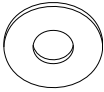

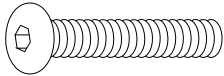
**Hardware Included:**

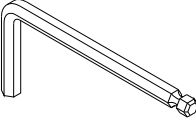
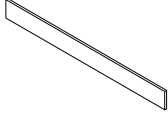
<p>(B) Flat Washer</p>  <p>Dia. 5/16" 6x</p>	<p>(C) Spring Washer</p>  <p>Dia. 5/16" 6x</p>	<p>(D) Bolt</p>  <p>Dia. 5/16"x1-1/4" 6x</p>
<p>(E) Wood dowel</p>  <p>Dia.10x30mm 2x</p>	<p>(F) Allen Key</p>  <p>5mm</p>	<p>(G) File Bar</p>  <p>2x</p>

**Assembly Instruction Steps:**

1. Take the drawer out of Cabinet (A) as shown.

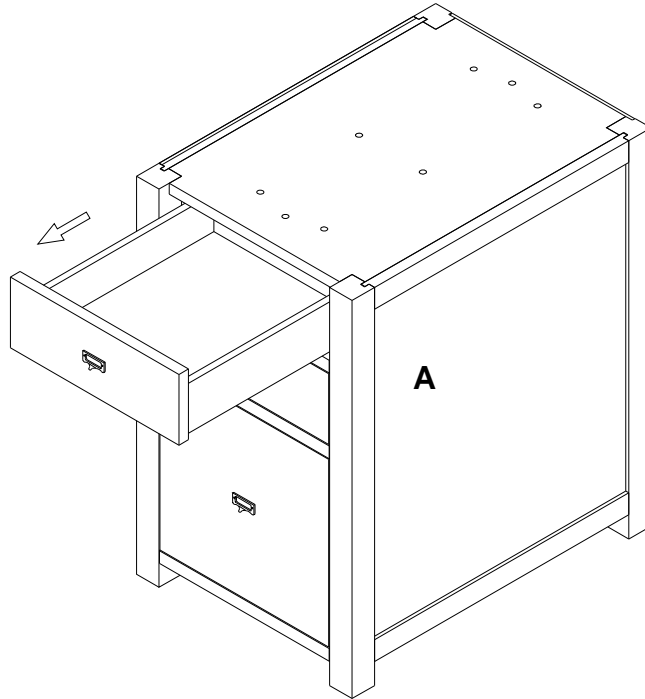

2. Insert Wood Dowel (E) to the Cabinet (A) as shown, and then attach DESKTOP (Sold separately) to Cabinet (A) using Flat Washer (B) , Spring Washer (C) and Bolt (D). **NOTE: DO NOT** fully tighten up until all bolts are attached. Finally tighten all bolts with Allen Key (F).

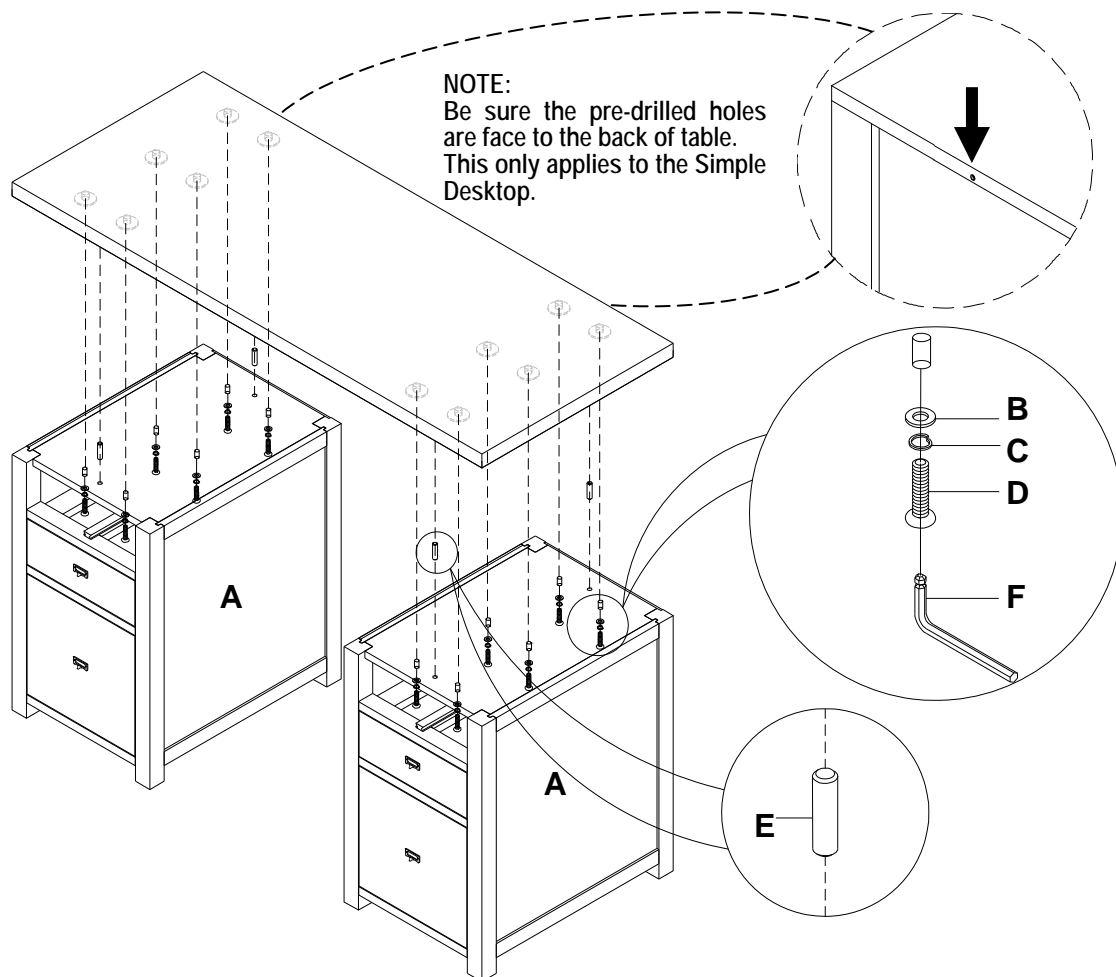

3. Install the drawer back to the cabinet as shown. Assembly is complete.

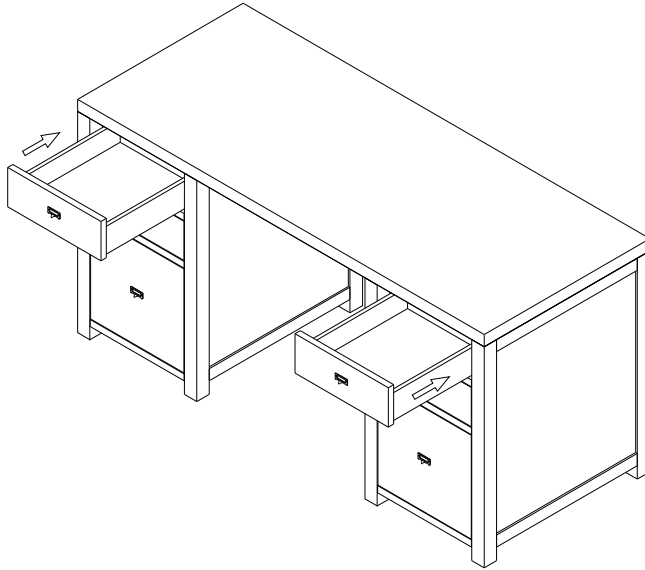

4. Open the bottom drawer, and put File Bars (G) in as shown.

**Adjusting the levelers:**

Due to an uneven floor, the furniture may not sit level due causing it to wobble. If the furniture wobbles, determine which corner does not touch the ground correctly. With two people follow these steps:

- 1) Carefully elevate the item slightly to provide access to the levelers attached to the bottom.
- 2) Turn the levelers until adequate contact will be made with the floor. Gently set down the piece and check stability.
- 3) Repeat steps until furniture sits firmly on the ground.

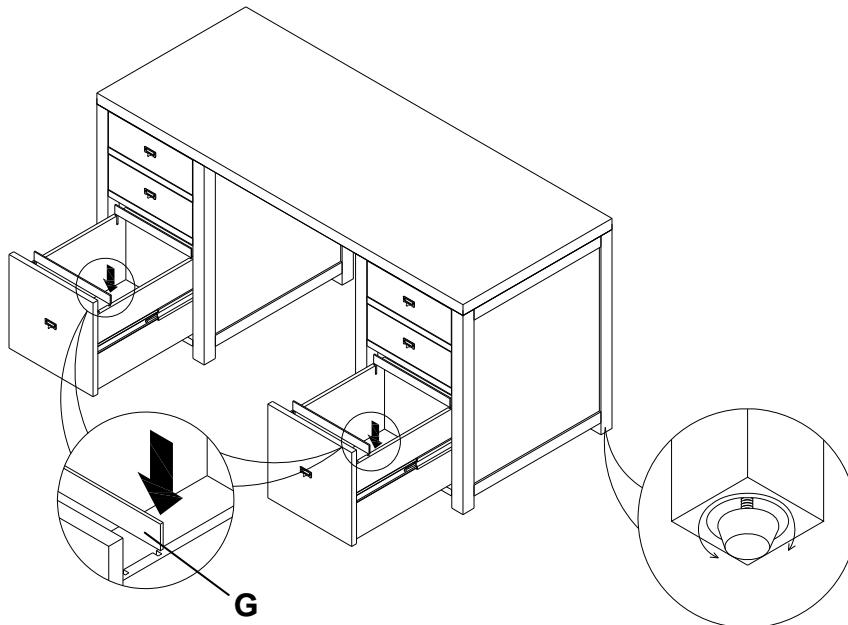

**Care Instructions:**

- Dust often using a clean, soft, dry and lint-free cloth.
- Blot spills immediately and wipe with a clean, damp, cloth.
- We do not recommend the use of chemical cleansers, abrasives or furniture polish on our lacquered finish.
- Hardware may loosen over time. Periodically check to make sure all connections are tight.  
Re-tighten if necessary.

Thank you for your purchase  
Stores | catalog