









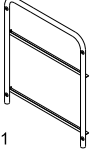
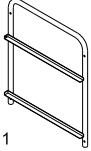
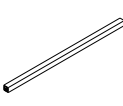
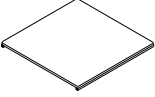
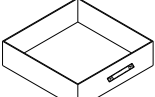
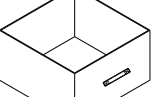
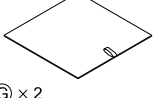

Fridge Cart

Assembly

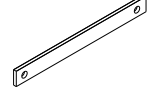
Please read all instructions before beginning assembly. Save all packaging materials until assembly is complete to avoid accidentally discarding smaller parts or hardware.

Step 1

 A × 1 Size: 560*500mm	 B × 1 Size: 560*500mm	 C × 2 Size: 12*12*550mm
 D × 1 Size: 550*555mm	 E × 1 Size: 544*544*99mm	 F × 1 Size: 544*544*245mm
 G × 2 Size: 534*534mm	 H × 8 Size: M5 *30mm	 I × 8 Size: Ø 18 *1.0mm
 J × 1 Size: M3*20*56mm	 K × 1 Size: 12*2*550mm	 L × 2 Size: G8/32T *8mm
 M × 2 Size: 73*37.5*81mm	 N × 2 Size: 59*37.5*81mm	

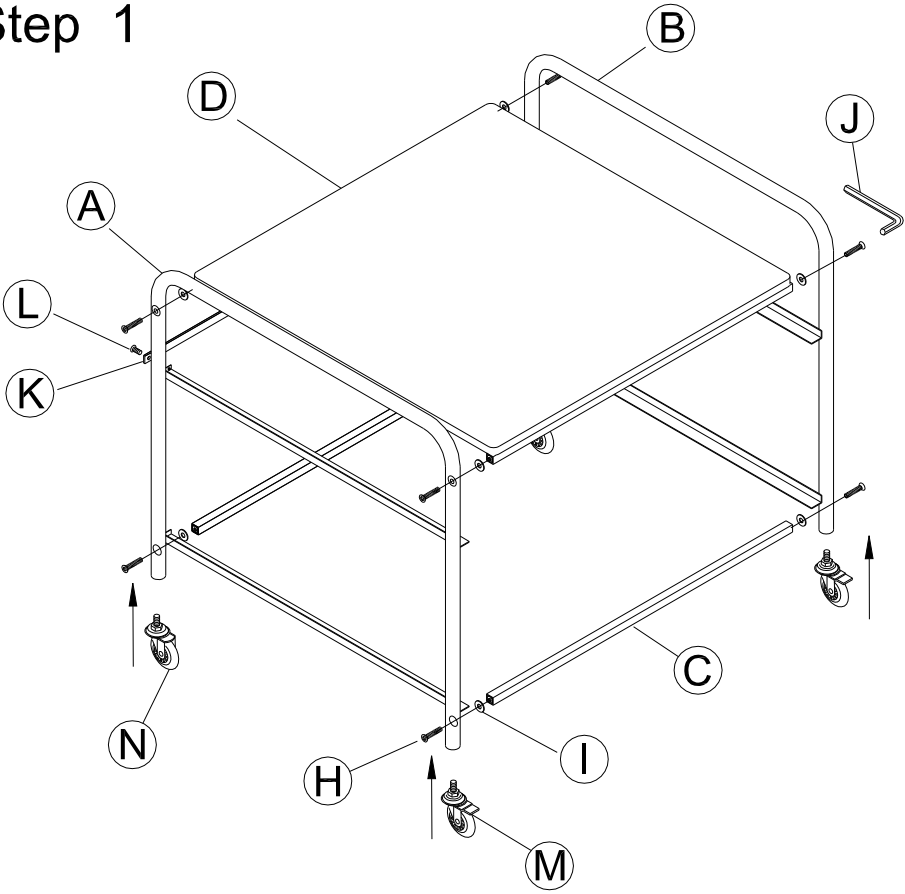

Step 2

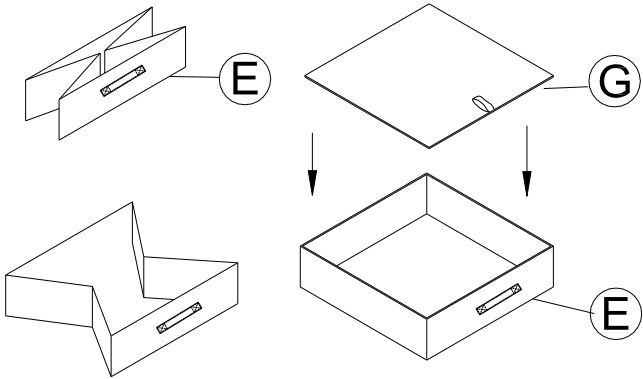

Step 3

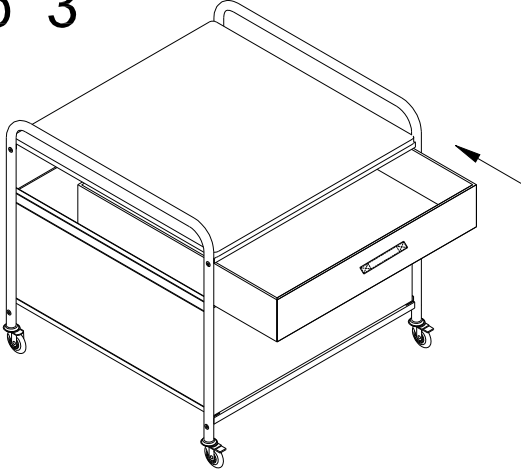

Assembly Instructions:

Note: For ease in assembling rolling cart, we recommend inserting screws and tightening only partially. When all screws have been inserted, tighten all connections fully.

1. Place the Right Frame (A) and Left Frame (B) in correct direction, as shown. Ensuring the pre-drilled holes are aligned properly, insert Plastic Washer (I) and Screw (H) through pre-drilled holes of the tube into the Top Panel (D) and tighten with the Wrench (J). Repeat for both sides.
Ensuring the pre-drilled holes are aligned properly, insert Screw (H) through pre-drilled holes of the tube into the Bottom Bar (C) and tighten with the Wrench (J). Repeat for both sides.
Ensuring the pre-drilled holes are aligned properly, insert Screw (L) through the Metal Sheet (K) and pre-drilled holes of the tube of the Right Frame (A) and the Left Frame (B) and tighten with screwdriver.
Carefully lay down the assembled unit on scratch-free surface. Insert Casters (M) and Casters (N) into the bottom of the Right and Left Frames (A & B) and then tighten until all are fully seated. Ensuring Casters (M) is at the front of roll cart
2. Assemble the Fabric Drawers (E & F & G) as shown.
3. Put all the 2 assembled Fabric Drawers (E & F) into the cart.
4. Rolling cart is now ready for use.

Care Instructions:

Wipe clean using a soft, dry cloth or static duster.

Always avoid the use of all chemicals and abrasive cleaners as they may damage the cart's finish.

Thank you for your purchase.
www.pbteen.com