

P O T T E R Y B A R N

Bethany Wall Basket

Note: For safe mounting, it is essential to use the proper hardware for your wall type. Be sure to consult your local hardware store to determine the hardware needed for your wall type (plaster, drywall, concrete, tile, etc.). These instructions are for drywall or stud mount only.

Note: MAXIMUM TOTAL WEIGHT CAPACITY IS 20 POUNDS (9.1KGS)

Parts Included:

- 4 Screws
- 4 Drywall anchors
- 2 Mounting plate
- 2 Hex screw
- 1 Allen wrench
- 1 Wall basket on two mounting brackets

Mounting Instructions:

1. Hold mounting plates at desired location. With a pencil, mark on the wall the screw hole locations. These marks will be used to determine the location of your mounting hardware.
Note: Stud mounting is always best, so try to position the mounting plates over a stud if possible. Use a stud finder to locate a stud in desired location. If there is no stud, the wall anchors/metal screws are both required.
2. Remove mounting plates. Use a carpenter's level or measure up from the floor at each mark to ensure basket will be level.
3. For dry wall mount: use a Phillip screwdriver to insert wall anchors. Slowly turn the anchors until they are threaded into the wall.
4. Attach mounting plates using hardware provided or the proper hardware for your wall type. Slide basket onto mounting plates. Secure by tightening hex screw with Allen wrench.

Care Instructions:

Wipe with a soft, dry cloth. To protect the finish, do not use household cleaners or abrasives.

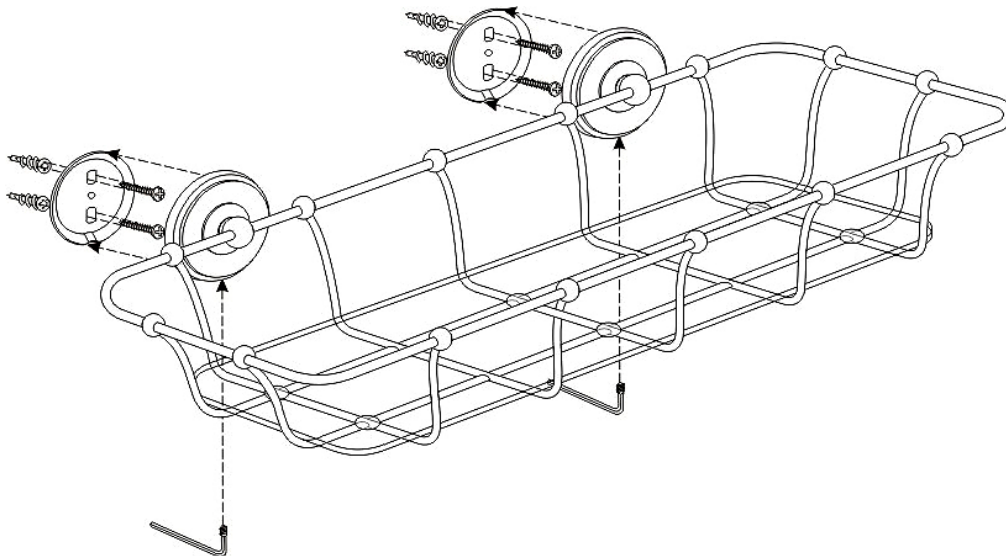

Thank you for your purchase
stores | catalog | www.potterybarn.com