



产品规格书 Specification



产品名称 Product name: 蓝牙模块 Bluetooth module

产品型号 Product model: F-3009

文件编号 Document No: XZX-SPEC-BT-RD-003

版 本 Version: V1.0

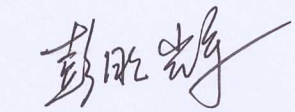
生效日期 Availability date: 2017-12-03

编制 Edit	审核 Review	批准 Approve
	 王杨 2017.12.1	

文件含芯中芯 (C-CHIP)机密文件，未经许可，不可外传
File include (C-CHIP) confidential documents, without permission, can not be disclosed



目录(Content)

一、产品概述 INTRODUCTION:	4
二、应用领域 APPLICATIONS:	4
三、基本特性 FEATURES:	4
四、模块方框图 PARAMETERS:	5
五、性能参数 PARAMETERS:	6
六、模块尺寸图 OUTLINE DIMENSION (MODULE FOOT PRINT):	7
七、模块脚位定义图 DEVICE PINOUT DIAGRAM:	7
八、引脚功能说明 PIN DEFINITION:	8
九、电路连接注意 CIRIUIT CONNECT NOTES:	10
十、注意事项 Notes:	10
十一、应用电路 APPLICATION CIRIUIT:	11
十二、推荐回流温度 THE REFLOW TEMPERATURE:	15



一、产品概述 INTRODUCTION:

F-3009 蓝牙模块为本公司自主开发的智能型无线音频数据双模传输产品，是低成本的高效率的立体声无线传输方案，模块采用了 CSR8670 芯片为模块提供了高品质的音质和兼容性，整体性能更优化。F-3009 蓝牙模块采用免驱动方式，客户只需要把模块接入应用产品，就可以快捷地实现音乐的无线传输，享受无线音乐的乐趣。

F-3009 is the Bluetooth module for intelligent wireless audio transmission products designed by our company . F-3009 also is the low cost stereo audio Bluetooth solution with high performance. The main chip uses Actions CSR8670 chip, providing the high quality and best compatibility. Without any driver, you can connect the module with your device to enjoy the high quality music easily.

二、应用领域 APPLICATIONS:

该模块主要用于短距离的音乐传输，可以方便地和笔记本电脑，手机，PDA 等数码产品的蓝牙设备相连，实现音乐的无线传输。

F-3009 is used for Bluetooth audio transmission and it is convenience to connect with mobile phone , personal computer , PDA and other digital products with Bluetooth hardware to enjoy the music wirelessly .The major application are included :

- ※ 蓝牙音响 Bluetooth speaker
- ※ 蓝牙立体声耳机 Bluetooth stereo headset
- ※ 免提电话 Hands-free Phone
- ※ 蓝牙无线传输音频 Bluetooth speaker with data transmission
- ※ 蓝牙数传应用 Bluetooth data transmission application
- ※ 支持移动互联周边设备 Supporting mobile Internet peripherals

三、基本特性 FEATURES:

Bluetooth Profiles

- ※ Bluetooth v4.0 specification support
- ※ Support for smartphone applications (apps)



- ※ Support for TWS
- ※ support for up to 6 capacitive touch sensor inputs
- ※ support for 802.11co-existence

~~~~~

Improved Audio Quality

- ※ Stereo codec with 2 channels ADC and up to 6 microphone inputs(include bias generators and digital microphone support)
- ※ Wind noise reduction
- ※ Multipoint support for HFP connection to 2 handsets for voice.

~~~~~

Music Enhancements

- ※ Configurable 5-band EQ for music playback (rock,pop, classical, jazz, dance etc)
- ※ SBC, MP3, AAC,APTX andAAC+ Faststream decoder
- ※ 16MHZ internal flash memory(64-bit write,45ns);optional support for 64Mb of external SPI flash
- ※ Support for voice recognition
- ※ Support for multi-language programmable audio prompts
- ※ CSR's proximity pairing and CSR's proximity connection
- ※ Multipoint support for A2DP connection to 2 A2DP sources for music playback
- ※ Talk-time extension

四、模块方框图 Module block diagram:

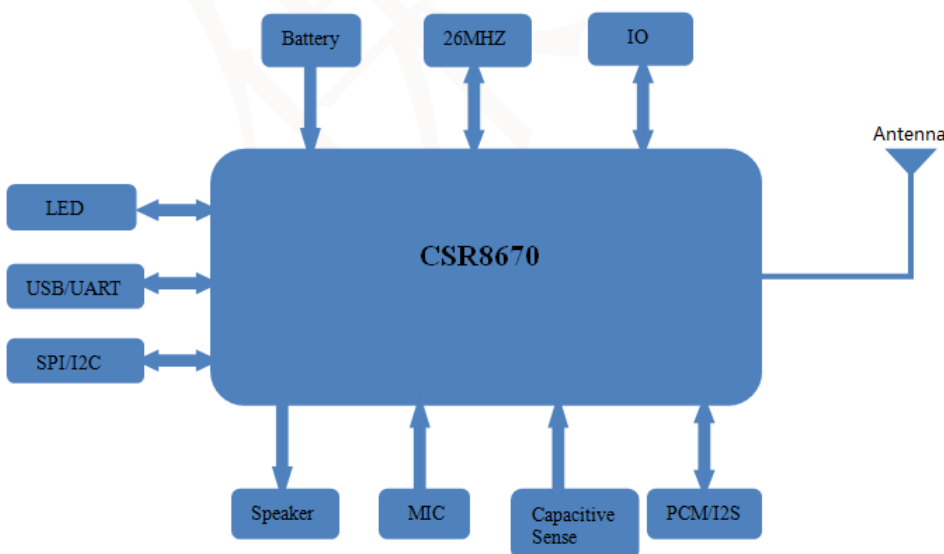



五、性能参数 PARAMETERS:

型号 Model	F-3009 v1.0
蓝牙规格 Bluetooth specification	Bluetooth V4.0
供电电压 Service voltage	GFSK, $\pi/4$ DQPSK, 8DPSK
工作电流 Supply voltage	3.3-4.2V
支持蓝牙协议 BLUETOOTH Profile	HFPV1.6,HSPV1.2,A2DPV1.2,AVRCPV1.0,PBAP,SPP,OPP,GOEP,FTP,HID 等
待机电流 Standby current	$\leq 30\text{mA}$
温度范围 Temperature range	$< 50\mu\text{A}$
无线传输范围 The wireless transmission range	-40°C to $+80^{\circ}\text{C}$
传输功率 Transmission power	$> 10(\text{M})$
频率范围 Frequency range	支持 CLASS1/CLASS2/CLASS3 最大可调 8dBm
对外接口 The external interface	$-80\text{dBm} < 0.1\% \text{BER}$
音频性能 Audio performance	2.402GHz-2.480GHz
音频信噪比 The audio signal to noise ratio	PIO, SPI,AIO,UART,USB,PCM,I2S,SPDIF,SPK(L/R)
支持系统 Support system	支持安卓 (android), 苹果 (IOS) 和 windows 系统
音频性能 Audio performance	支持 AAC, MP3, SBC,AAC+ Faststream , APTX
音频信噪比 The audio signal to noise ratio	$\geq 75\text{dB}$
失真度 Degree of distortion	$\leq 0.1\%$
模块尺寸 Module size	22*15*2MM



六、模块尺寸图 OUTLINE DIMENSION (MODULE FOOT PRINT):

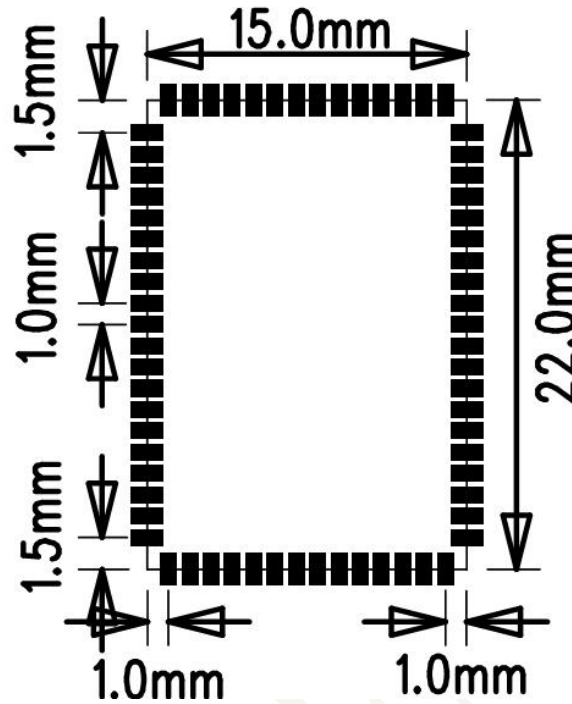

七、模块脚位定义图 DEVICE PINOUT DIAGRAM

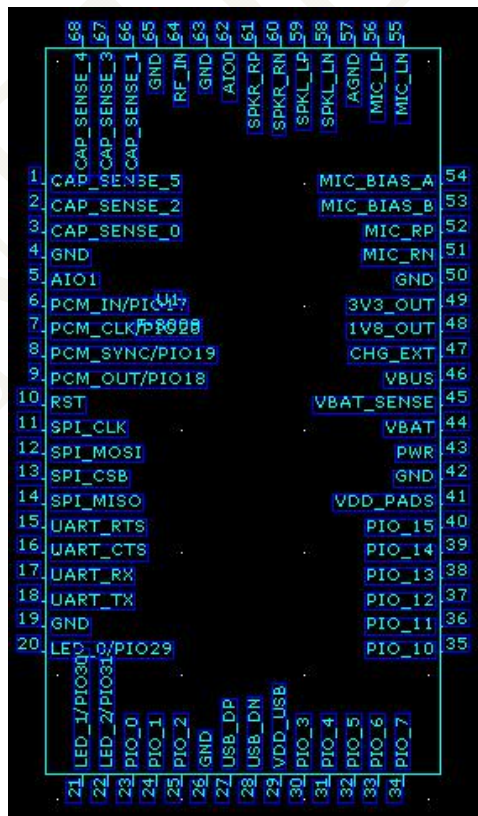



八、引脚功能说明 PIN DEFINITION:

Pin	Symb	I/O	Description
1	CAP _SENSE5	Aualogue input	Capacitive touch sensor input
2	CAP _SENSE2	Aualogue input	Capacitive touch sensor input
3	CAP _SENSE0	Aualogue input	Capacitive touch sensor input
4	GND	GND	GND
5	AIO1	Bidirentional	Analogue programmable input/output line
6	PCM_IN_PIO17	Bidirentional with weak pull_down	Synchronous data input.alternative funtion PIO17
7	PCM_CLK_PIO20	Bidirentional with weak pull_down	Synchaon data clock . alternative funtion PIO20
8	PCM_SYNC_PIO19	Bi-directional with weak pull-down	Synchaon data sync . alternative funtion PIO19
9	PCM_OUT_PIO18	Bi-directional with weak pull-down	Synchaon data output . alternative funtion PIO18
10	RST	Input with strong pull_up	Reset if low .
11	SPI_CLK	Input with weak pull_down	SPI clock
12	SPI_MOSI	Input with weak pull_down	SPI data input
13	SPI_CSB	Input with weak pull_down	Chip select for SPI,active low
14	SPI_MISO	Input with weak pull_down	SPI data output
15	UART_RTS	Bi-directional with weak pull-down	UART request to send .active low, Alternative funtion PIO16
16	UART_CTS	Bi-directional with weak pull-down	
17	UART_TX	Bi-directional with strong pull-down	UART data output
18	UART_RX	Bi-directional with weak pull-down	UART data input
19	GND	GND	GND
20	LED0_PIO29	Open drain	LED driver .Alternative function PIO29
21	LED1_PIO30	Open drain	LED Driver. Alternative function PIO30
22	LED2_PIO31	Open drain	LED Driver. Alternative function PIO31
23	PIO_0	Bi-directional with weak pull-down	programmable input/output line
24	PIO_1	Bi-directional with weak pull-down	programmable input/output line
25	PIO_2	Bi-directional with weak pull-down	programmable input/output line
26	GND	GND	GND



深圳市芯中芯科技有限公司
SHENZHENSHI XINZHONGXIN TECHNOLOGY CO., LTD.

F-3009 V1.0

27	USB_DN	Bidirectional	USB_DN
28	USB_DP	Bidirectional	USB_DP
29	VDD_USB	power	Positive supply for USB ports
30	PIO_3	Bi-directional with weak pull-down	programmable input/output line
31	PIO_4	Bi-directional with weak pull-down	programmable input/output line
32	PIO_5	Bi-directional with weak pull-down	programmable input/output line
33	PIO_6	Bi-directional with weak pull-down	programmable input/output line
34	PIO_7	Bi-directional with weak pull-down	programmable input/output line
35	PIO_10	Bi-directional with weak pull-down	programmable input/output line
36	PIO_11	Bi-directional with weak pull-down	programmable input/output line
37	PIO_12	Bi-directional with weak pull-down	programmable input/output line
38	PIO_13	Bi-directional with weak pull-down	programmable input/output line
39	PIO_14	Bi-directional with weak pull-down	programmable input/output line
40	PIO_15	Bi-directional with weak pull-down	programmable input/output line
41	VDD_PADS	Power supply	1.8V positive supply input for input/output ports:
42	GND	GND	GND
43	PWR	Power supply	Power_en
44	VBAT	Power supply	Battery positive terminal
45	Vbat_SENSE	Power supply	Battery charge sense input
46	VBUS	Power supply	Battery charge input
47	CHG_EXT	Power	External battery charge control
48	1V8_OUT	Power	1V8_OUT
49	3V3_OUT	Power	USB_3V3_OUT
50	GND	GND	GND
51	MIC_RN	Analogue in	Microphone input negative,right
52	MIC_RP	Analogue in	Microphone input positive ,right
53	MIC_BIAS_B	Analogue out	Microphone bias B
54	MIC_BIAS_A	Analogue out	Microphone bias A



5	MIC_LN	Analogue in	Microphone input negative ,left
56	MIC_LP	Analogue in	Microphone input positive ,left
57	AGND	Analogue GND	Analogue GND
58	SPKL_LN	Analogue in	Speaker output negative,left
59	SPKL_LP	Analogue in	Speaker output positive,left
60	SPKR_RN	Analogue in	Speaker output negative,right
61	SPKR_RP	Analogue in	Speaker output positive,right
62	AIO0	Bidirentional	Analogue programmable input/output line
63	GND	GND	GND
64	RF_IN	RF	RF OUTPUT
65	GND	GND	GND
66	CAP _SENSE1	Aualogue input	Capacitive touch sensor input
67	CAP _SENSE3	Aualogue input	Capacitive touch sensor input
68	CAP _SENSE4	Aualogue input	Capacitive touch sensor input

九、电路连接注意 CIRIUIT CONNECT NOTES:

F-3009 v1.0 外接功放的时候，必须接差分输入的功放，如果不接差分输入的功放，必须接一个运放平衡两个差分的电平，否则会有“啪啪”的冲击声。

When F-3009 V1.0 connected a external power amplifier ,which must be a differential input amplifier, if not,, must be connected to an operational amplifier to balance two difference level, otherwise there will be "impact sound Pa Pa".

十、注意事项 Notes

A. 如果模组天线旁边有电池，金属物，液晶屏，喇叭等，要求离天线距离至少 15mm

If the module antenna next to the battery、 metal, liquid crystal screen, loudspeaker, at least keep them away from antenna distance 15mm

B. layout 时供电线路建议使用星形走线，并确保蓝牙模组供电线性度要好，还有 BT 的地须与运放，功放，MCU 等的地分开，而且 BT 下侧不可有其他干扰地

When layout the power supply line recommended star line, and to ensure that the Bluetooth module Power supply lines is better , and BT should be with the amplifier, power amplifier, MCU, separately, and the underside of the BT has no other interference.

C. 天线周围不可走控制线，电源线，音频线，MIC 等干扰线.

Please don' t let control lines, power lines, audio lines, MIC and other interference lines around



the antenna .

D. 如果模组天线附近有排座，外壳有金属铁网等对信号有影响的，建议选用专业的高增益天线。

If the module antenna near the row seats, Because of metal will block the signal transmission, it is recommended to use professional high-gain antenna.

十一、应用电路 APPLICATION CIRCUIT:

1) 完整应用电路图 Complete application circuit diagram

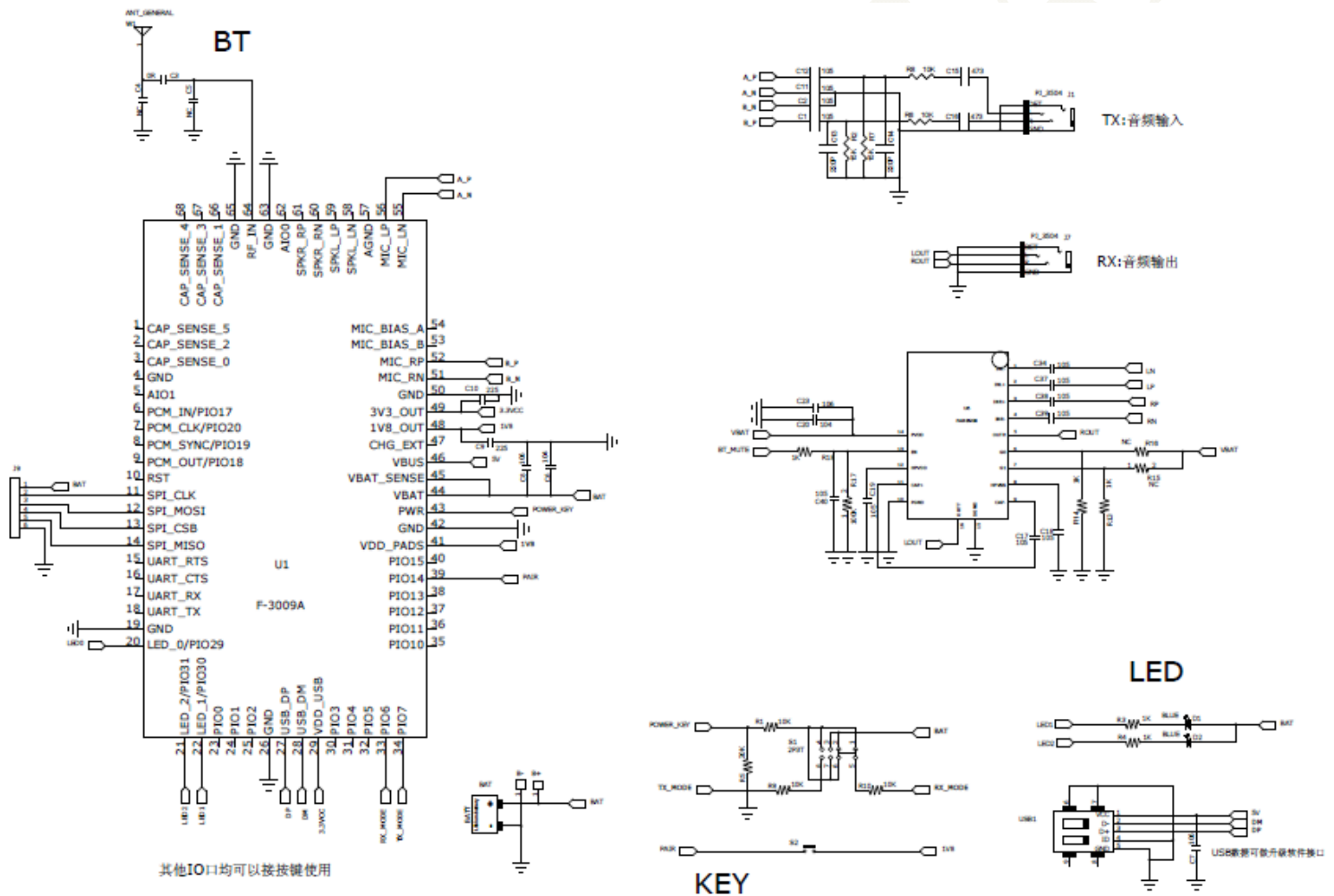

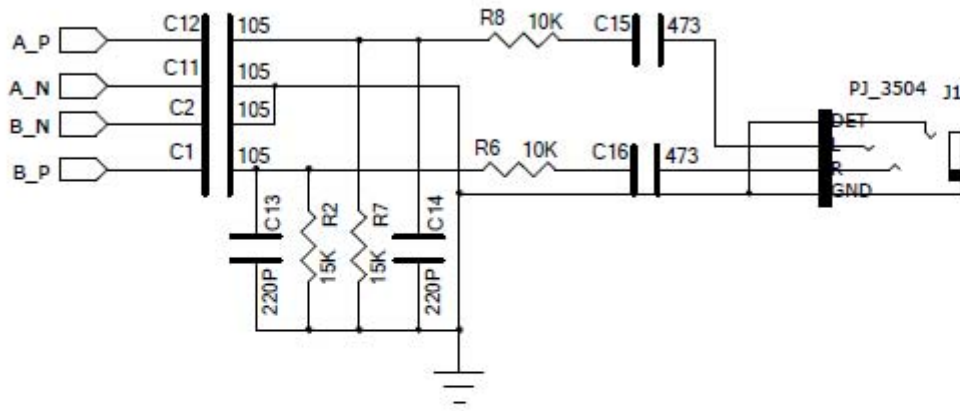

TX: 音频输入

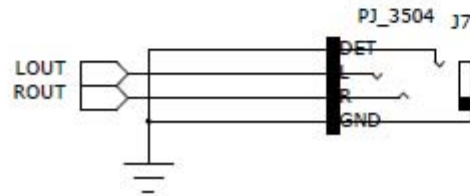

RX: 音频输出

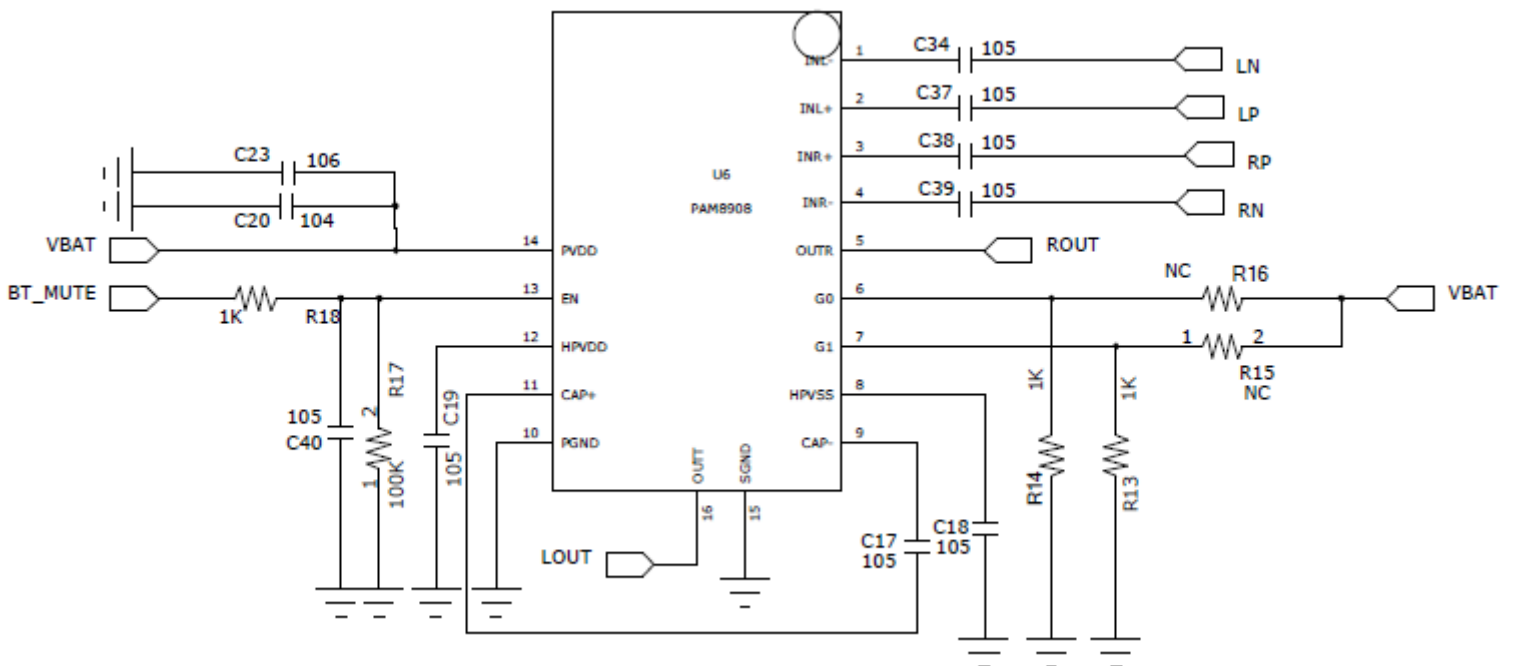

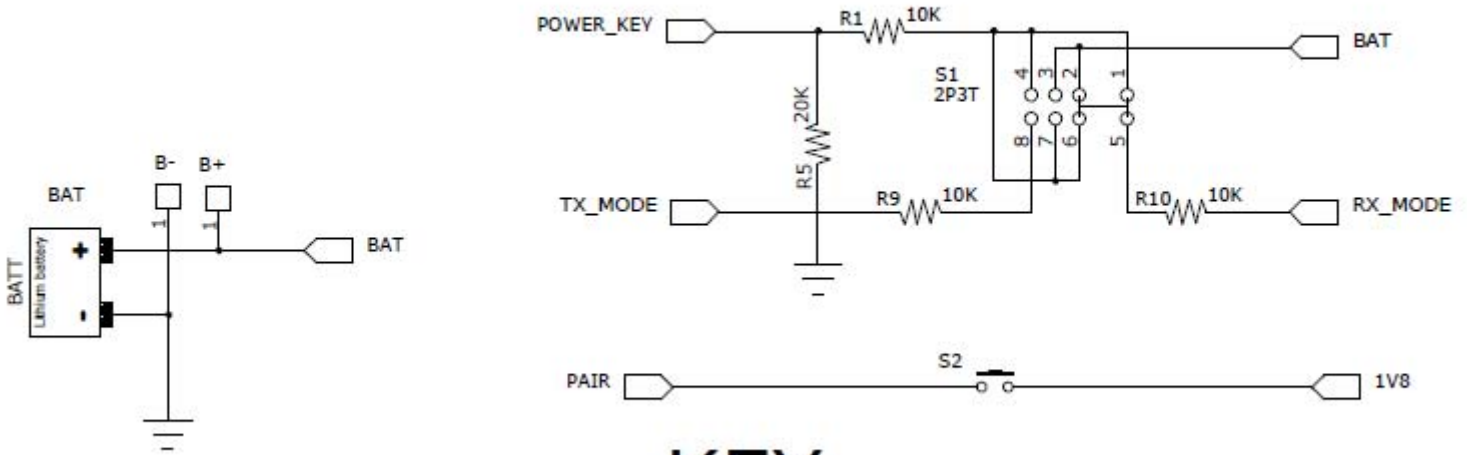

KEY LED

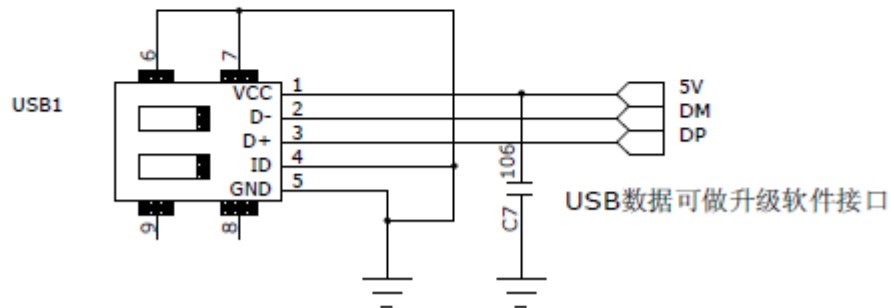
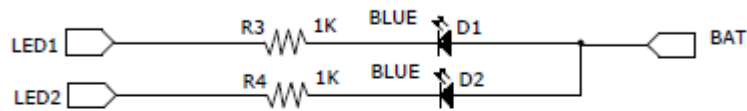



十二、推荐回流温度 THE REFLOW TEMPERATURE

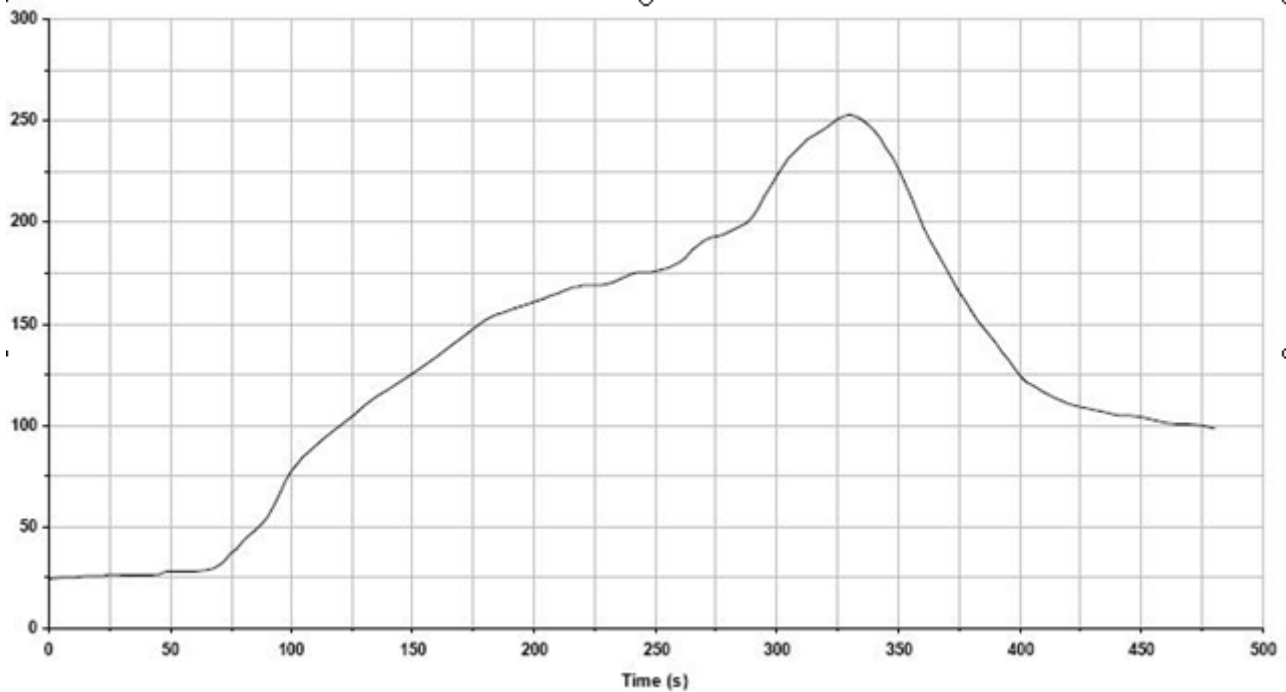

Key features of the profile:

- Initial Ramp=1-2.5°C/sec to 175°C equilibrium
- Equilibrium time=60 to 80 seconds
- Ramp to Maximum temperature (250°C)=3°C/sec Max
- Time above liquidus temperature(217°C): 45 - 90 seconds
- Device absolute maximum reflow temperature: 250°C